

VERANO SOUTH P.U.D. 1 - POD G - PLAT NO. 1

BEING A PORTION OF SECTIONS 32 AND 33, TOWNSHIP 36 SOUTH, RANGE 39 EAST,
AND SECTIONS 4 AND 5, TOWNSHIP 37 SOUTH, RANGE 39 EAST,
CITY OF PORT ST. LUCIE, ST. LUCIE COUNTY, FLORIDA.

PLAT BOOK
PAGE
FILE NO.
DATE
TIME

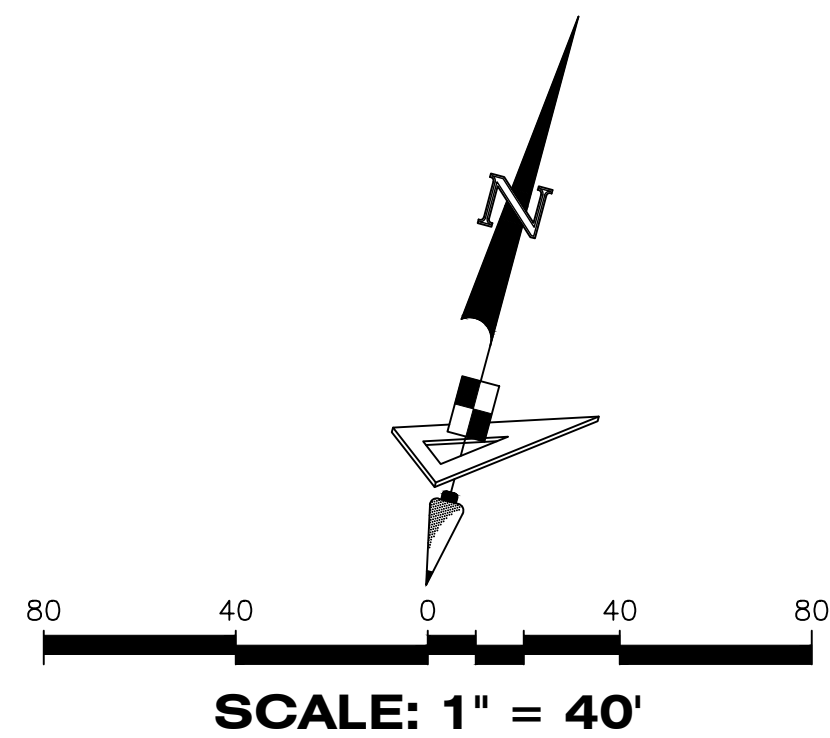
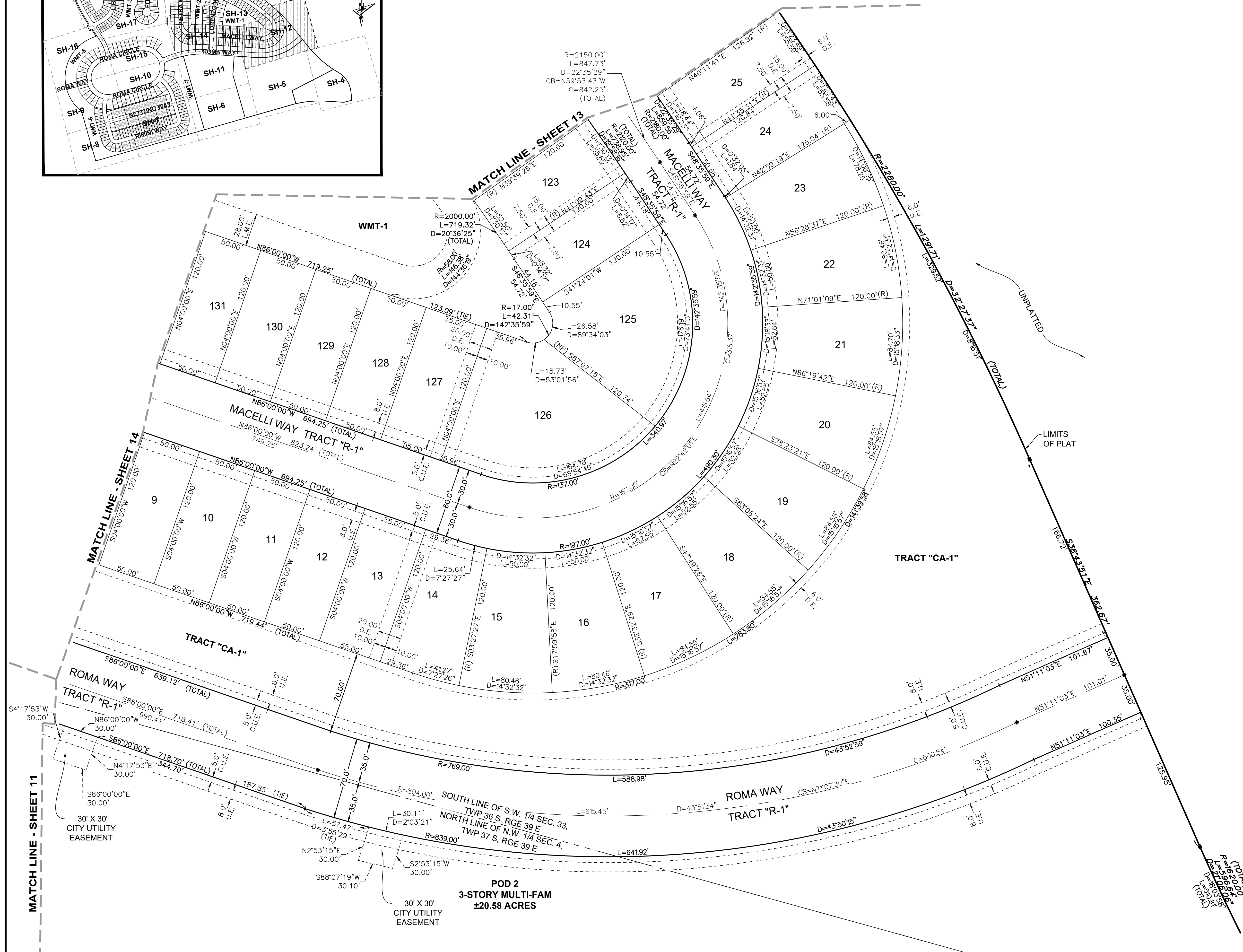
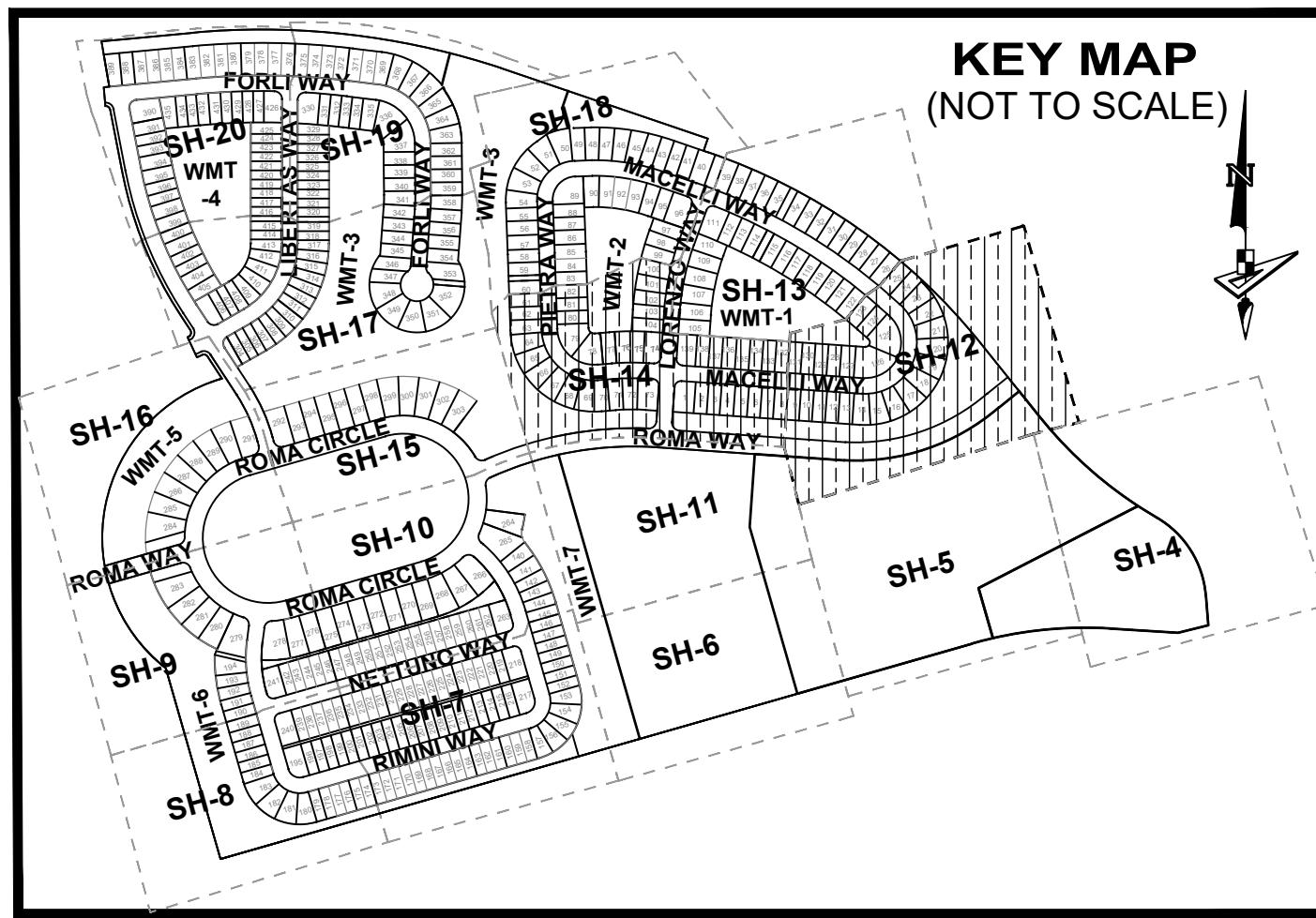

LEGEND

- P.B. ----- Plat Book
- Pg(s). ----- Page(s)
- S.F.W.M.D. ----- South Florida Water Management District
- A.E. ----- Access Easement
- C.U.E. ----- City Utility Easement
- D.E. ----- Drainage Easement
- E.A.E. ----- Emergency Access Easement
- L.M.E. ----- Lake Maintenance Easement
- U.E. ----- Utility Easement
- L.E. ----- Landscape Easement
- WMT ----- Stormwater Management Tract
- ⊙ ----- Centerline
- R/W ----- Right-of-Way
- P.U.D. ----- Planned Unit Development
- R ----- Radius
- L ----- Arc Length
- D ----- Delta-Central Angle
- CB ----- Chord Bearing
- C ----- Chord Length
- (R) ----- Radial
- (NR) ----- Non-Radial
- C.M. ----- Concrete Monument
- LB ----- Licensed Business
- ----- Indicates (PRM) Permanent Reference Monument - 4" x 4" Concrete Monument LB7768 (Unless Otherwise Noted)
- ----- Indicates (PCP) Permanent Control Point LB7768

VERANO SOUTH P.U.D. I - POD G - PLAT NO. I

BEING A PORTION OF SECTIONS 32 AND 33, TOWNSHIP 36 SOUTH, RANGE 39 EAST,
AND SECTIONS 4 AND 5, TOWNSHIP 37 SOUTH, RANGE 39 EAST,
CITY OF PORT ST. LUCIE, ST. LUCIE COUNTY, FLORIDA.

PLAT BOOK

PAGE

FILE NO.

DATE

TIME

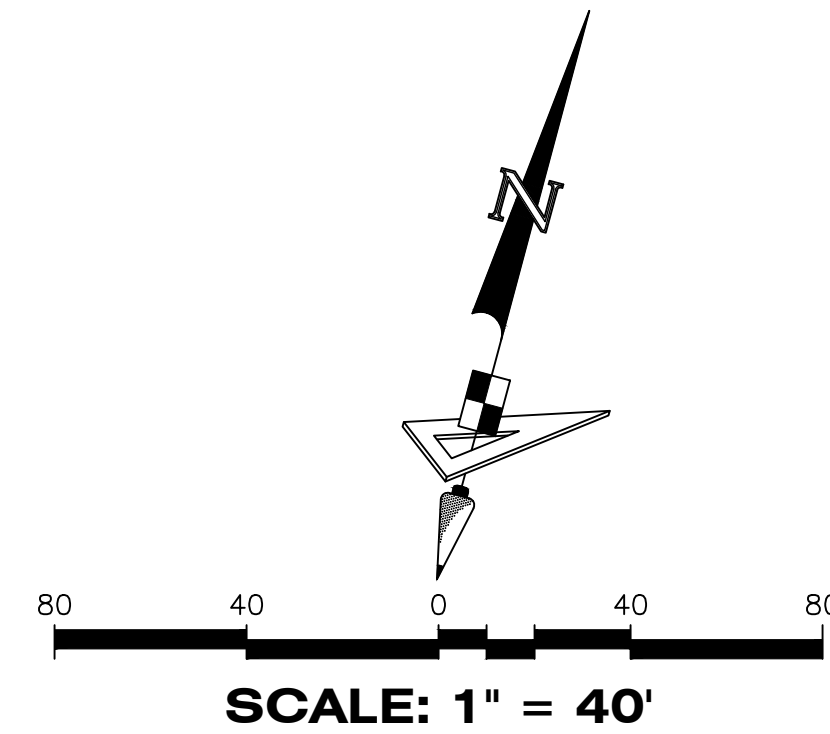
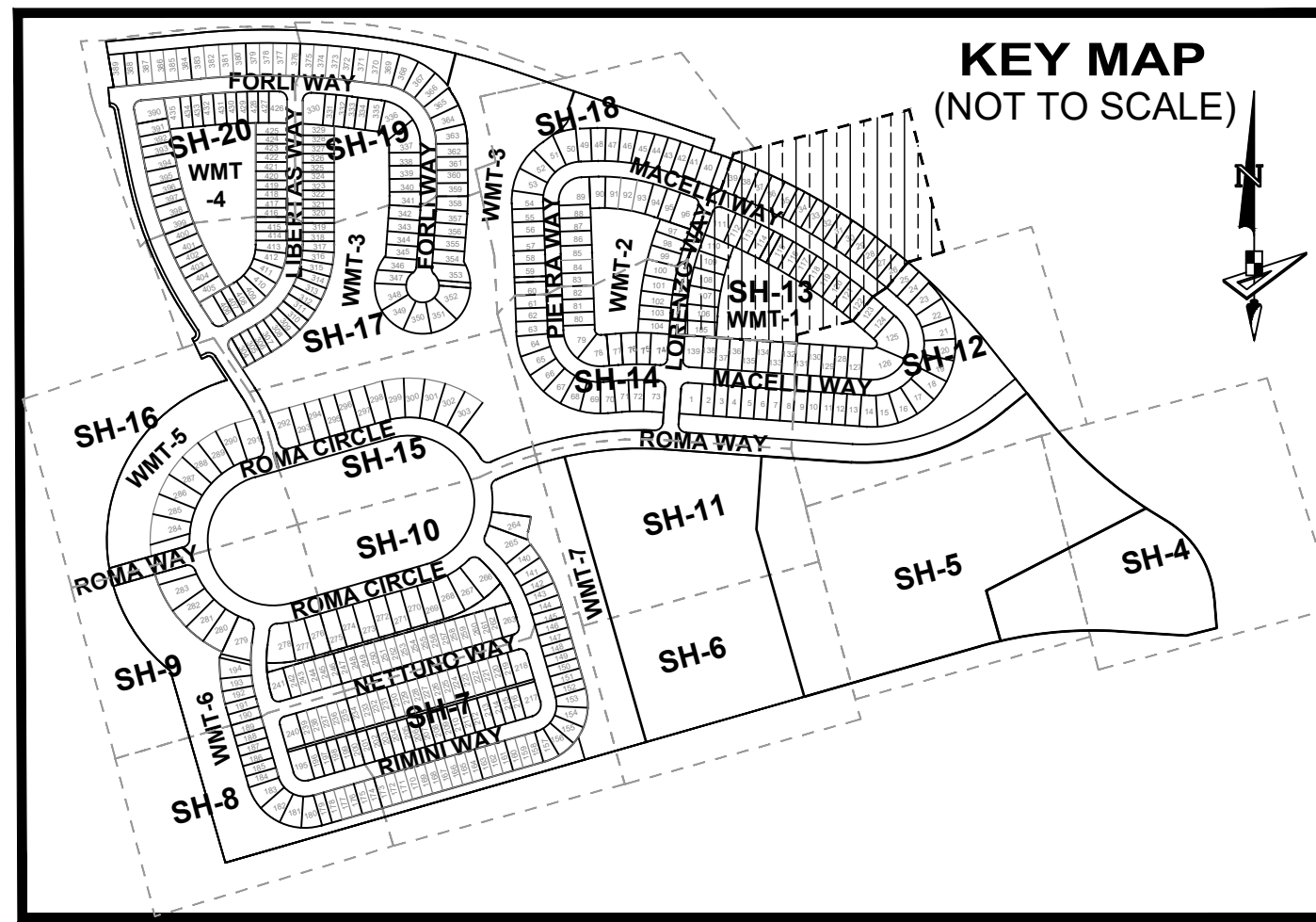

LEGEND

- P.B. ----- Plat Book
- Pg(s) ----- Page(s)
- S.F.W.M.D. ----- South Florida Water Management District
- A.E. ----- Access Easement
- C.U.E. ----- City Utility Easement
- D.E. ----- Drainage Easement
- E.A.E. ----- Emergency Access Easement
- L.M.E. ----- Lake Maintenance Easement
- U.E. ----- Utility Easement
- L.E. ----- Landscape Easement
- WMT ----- Stormwater Management Tract
- ℄ ----- Centerline
- R/W ----- Right-of-Way
- P.U.D. ----- Planned Unit Development
- R ----- Radius
- L ----- Arc Length
- D ----- Delta-Central Angle
- CB ----- Chord Bearing
- C ----- Chord Length
- (R) ----- Radial
- (NR) ----- Non-Radial
- C.M. ----- Concrete Monument
- LB ----- Licensed Business
- ----- Indicates (PRM) Permanent Reference Monument-4"x4" Concrete Monument LB7768 (Unless Otherwise Noted)
- ----- Indicates (PCP) Permanent Control Point LB7768

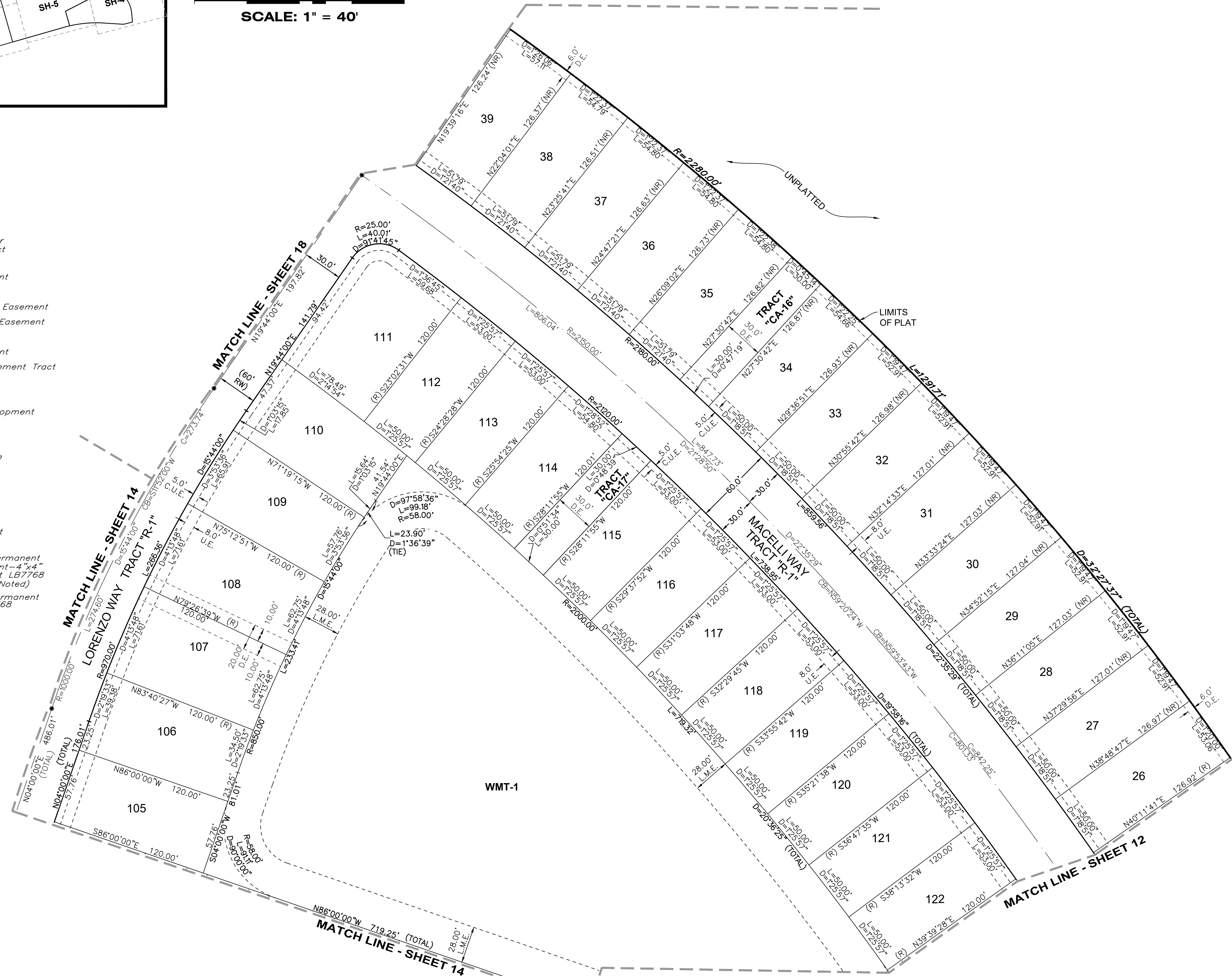

VERANO SOUTH P.U.D. I - POD G - PLAT NO. 1

BEING A PORTION OF SECTIONS 32 AND 33, TOWNSHIP 36 SOUTH, RANGE 39 EAST,
AND SECTIONS 4 AND 5, TOWNSHIP 37 SOUTH, RANGE 39 EAST,
CITY OF PORT ST. LUCIE, ST. LUCIE COUNTY, FLORIDA.

PLAT BOOK
PAGE
FILE NO.
DATE
TIME

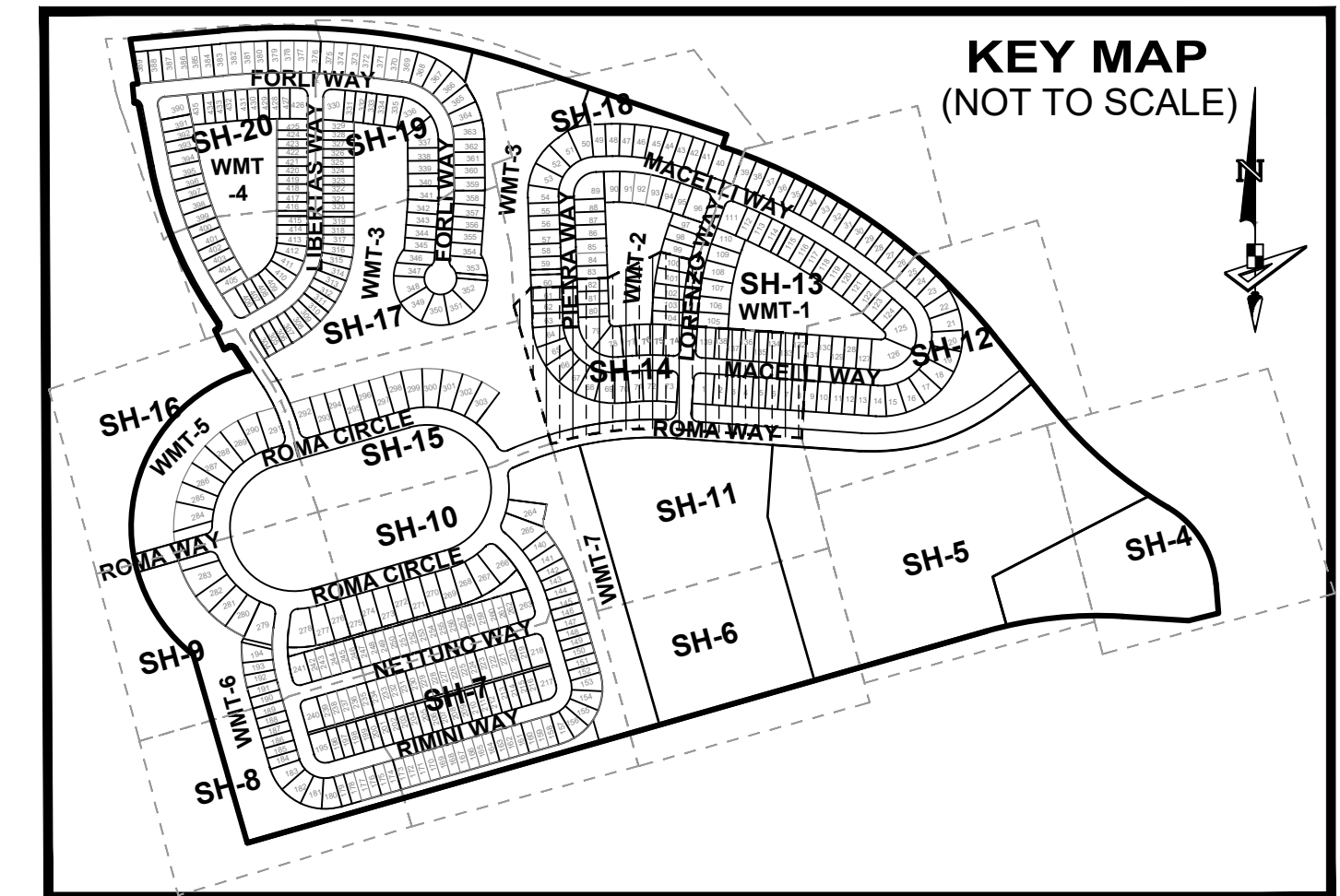
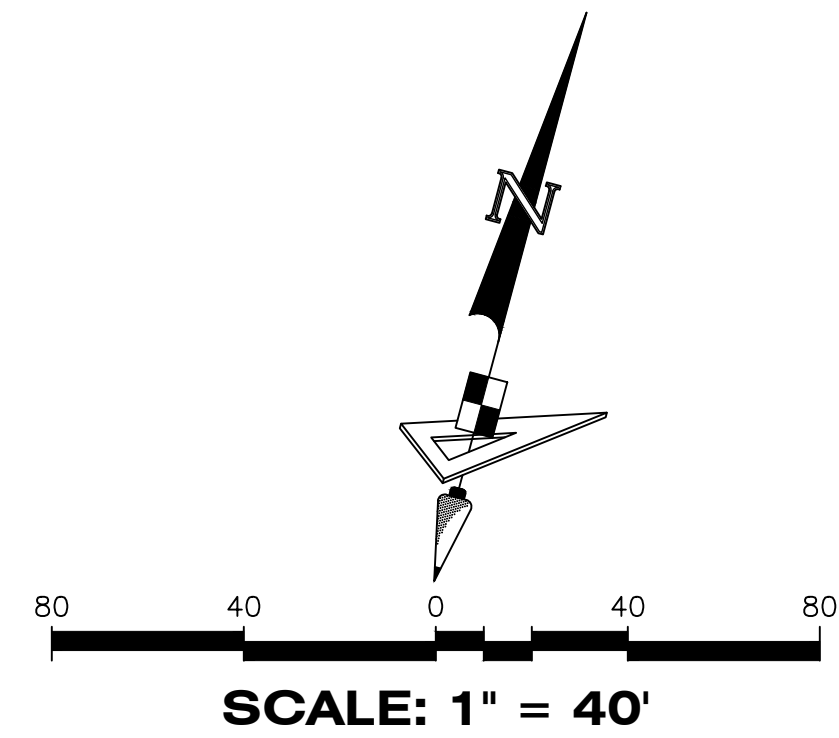

LEGEND

- | | |
|--|--|
| P.B. ----- Plat Book | R/W ----- Right-of-Way |
| Pg(s). ----- Page(s) | P.U.D. ----- Planned Unit Development |
| S.F.W.M.D. ----- South Florida Water Management District | R ----- Radius |
| A.E. ----- Access Easement | L ----- Arc Length |
| C.U.E. ----- City Utility Easement | D ----- Delta-Central Angle |
| D.E. ----- Drainage Easement | CB ----- Chord Bearing |
| E.A.E. ----- Emergency Access Easement | C ----- Chord Length |
| L.M.E. ----- Lake Maintenance Easement | (R) ----- Radial |
| U.E. ----- Utility Easement | (NR) ----- Non-Radial |
| L.E. ----- Landscape Easement | C.M. ----- Concrete Monument |
| WMT ----- Stormwater Management Tract | LB ----- Licensed Business |
| ⊕ ----- Centerline | ■ ----- Indicates (PRM) Permanent Reference Monument-4"x4" Concrete Monument LB7768 (Unless Otherwise Noted) |
| | ● ----- Indicates (PCP) Permanent Control Point LB7768 |

VERANO SOUTH P.U.D. I - POD G - PLAT NO. 1

BEING A PORTION OF SECTIONS 32 AND 33, TOWNSHIP 36 SOUTH, RANGE 39 EAST,
AND SECTIONS 4 AND 5, TOWNSHIP 37 SOUTH, RANGE 39 EAST,
CITY OF PORT ST. LUCIE, ST. LUCIE COUNTY, FLORIDA.

PLAT BOOK
PAGE
FILE NO.
DATE
TIME

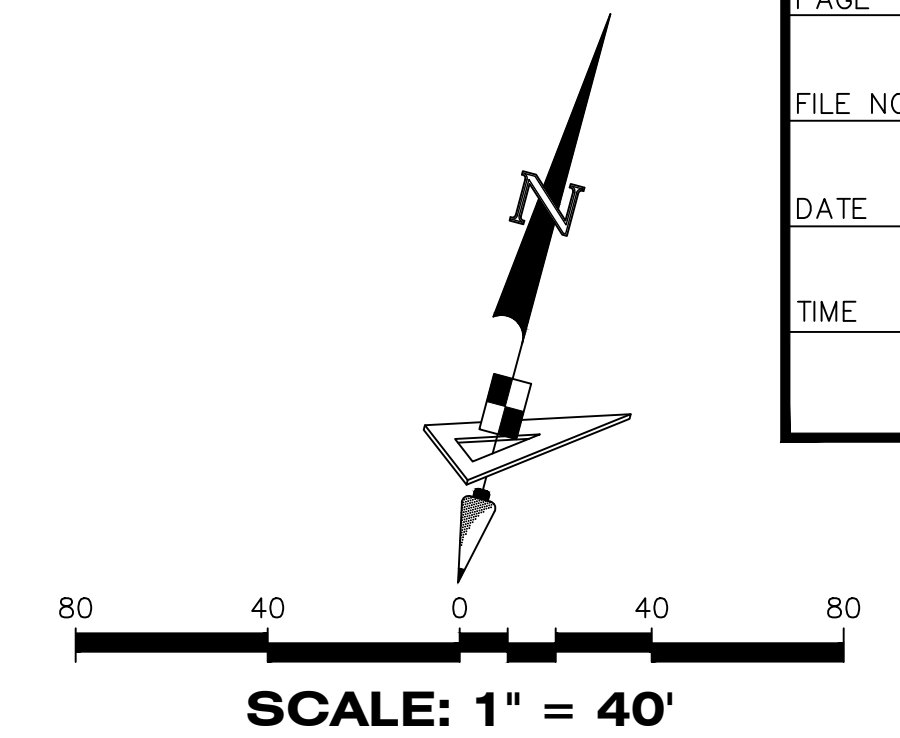
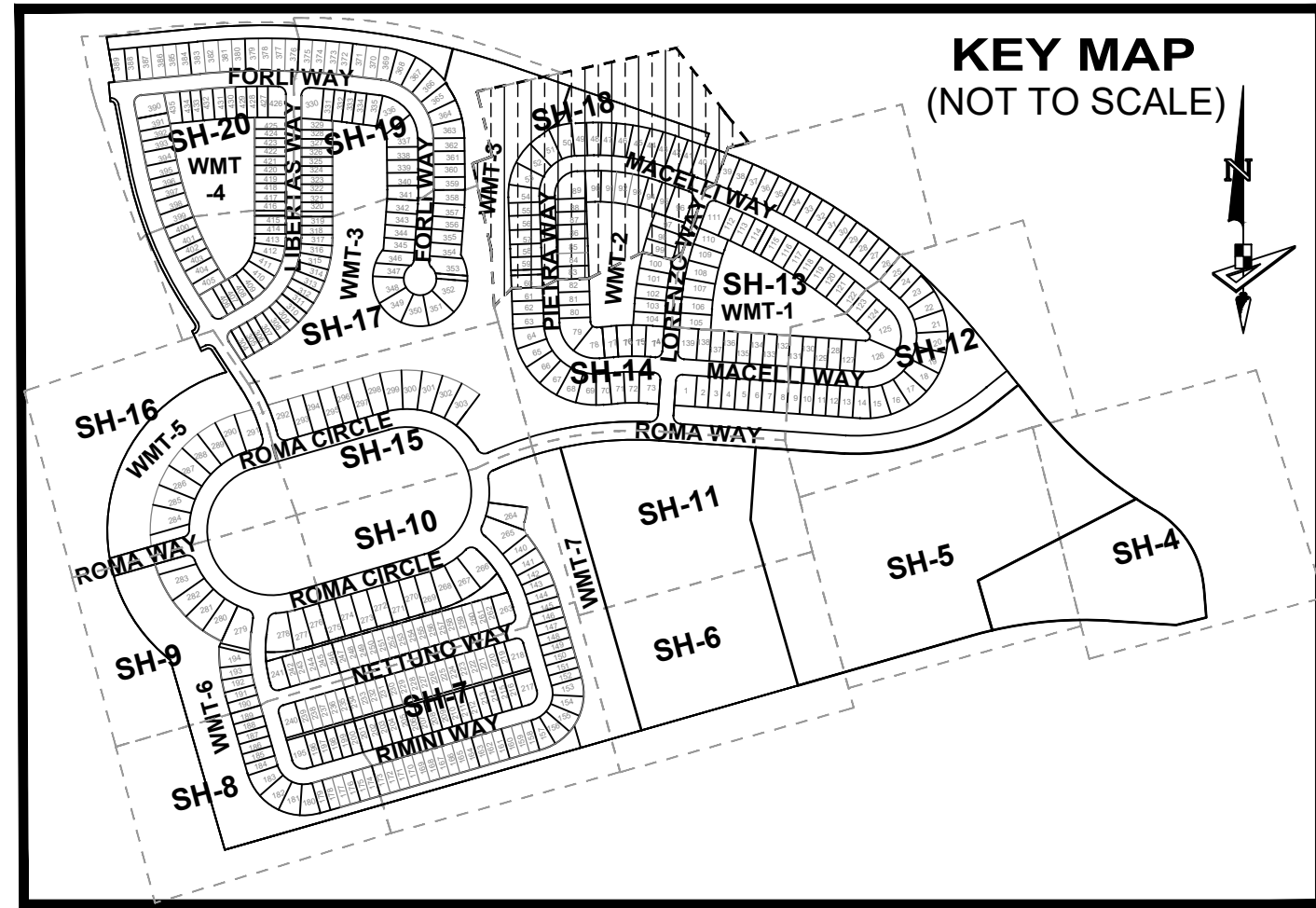

- LEGEND**
- P.B. ----- Plat Book
 - Pg(s) ----- Page(s)
 - S.F.W.M.D. ----- South Florida Water Management District
 - A.E. ----- Access Easement
 - C.U.E. ----- City Utility Easement
 - D.E. ----- Drainage Easement
 - E.A.E. ----- Emergency Access Easement
 - L.M.E. ----- Lake Maintenance Easement
 - U.E. ----- Utility Easement
 - L.E. ----- Landscape Easement
 - WMT ----- Stormwater Management Tract
 - ⊙ ----- Centerline
 - R/W ----- Right-of-Way
 - P.U.D. ----- Planned Unit Development
 - R ----- Radius
 - L ----- Arc Length
 - D ----- Delta-Central Angle
 - CB ----- Chord Bearing
 - C ----- Chord Length
 - (R) ----- Radial
 - (NR) ----- Non-Radial
 - C.M. ----- Concrete Monument
 - LB ----- Licensed Business
 - ----- Indicates (PRM) Permanent Reference Monument - 4"x4" Concrete Monument LB7768 (Unless Otherwise Noted)
 - ----- Indicates (PCP) Permanent Control Point LB7768

