

**CITY OF PORT ST. LUCIE
CONTRACT # 202110104**

This CONTRACT executed this ____ day of _____, 2022, by and between the CITY OF PORT ST. LUCIE, a Florida municipal corporation, hereinafter called "City" party of the first part, and ENVIRONMENT-ONE CORPORATION, a New York corporation with an address at 2773 Balltown Road, Niskayuna, NY 12309, hereinafter called "Contractor," party of the second part. City and Contractor may be referred to individually as a "party" or collectively as "the parties."

**SECTION I
RECITALS**

In consideration of the below agreements and covenants set forth herein, the parties agree as follows:

WHEREAS, Contractor is a foreign corporation authorized to do business in the State of Florida; and

WHEREAS, the City wishes to contract with Contractor for the supply of the sewage grinder pumps and related training and technical support services set forth on Exhibit "A" on the terms and conditions set forth herein; and

WHEREAS, Contractor is qualified, willing and able to provide the specified products and services on the terms and conditions set forth herein.

NOW THEREFORE, in consideration of the premises and the mutual covenants herein name, the parties agree as follows:

The Recitals set forth above are hereby incorporated into this Contract and made a part of hereof for reference.

**SECTION II
NOTICES**

Project Manager: City of Port St. Lucie, Utility Systems Department
Timothy Richards, Administrator, D&C
Michael Rossignol, Warehouse Supervisor
City of Port St. Lucie, Utility Systems Dept.
900 S.E. Ogden Lane
Port St. Lucie, Florida 34983
Telephone (772) 344-4228 Fax 772-873-6405
Email: TRichards@cityofpsl.com

City Contract Administrator: City of Port St. Lucie
Procurement Management Department
Attn: Jason Bezak, Procurement Agent I
121 SW Port St. Lucie, Blvd.



Port St. Lucie, FL. 34984
Telephone: 772-344-4068 / Fax: 772-871-7337
Email: JBezak@cityofpsl.com

Contractor: Environment-One Corporation
Eric LaCoppola, President
Chris Nedwick, National Sales Development Manager
2773 Balltown Rd, Niskayuna, NY 12309
Telephone: 518-579-3053
Email: elacoppola@eone.com

SECTION II **DESCRIPTION OF SERVICES TO BE PROVIDED**

Contractor will be a Single Source Contractor. Contractor has agreed to supply the sewage grinder pumps and related equipment (the "Products") and related training and technical support services (the "Services") set forth on Exhibit "A" attached hereto and incorporated herein by reference to the City, and the City has agreed to purchase from Contractor 100% of its requirements for the Products and Services during the term of this Contract, to be used throughout the City's Utility System. The City will issue a written annual order for the Products (showing a monthly delivery amount for the Products to be delivered for each 3-month period in that annual period), and the City will issue written order releases against that order for each 3-month period. Contractor will deliver the Products against the written order releases issued by the City.

Scope of work: The Contractor is providing Products and Services in the State of Florida. The City may place orders in truckload quantity. However, this cannot be guaranteed. Therefore, the Contractor must agree to deliver less than truckload quantities, (when required by the City) at the contract price; provided that the additional shipping charges will be quoted in advance of shipments, prepaid by Contractor, added to the invoice of shipped products, and payable by the City.

Floor Stock - Contractor must be an ongoing manufacturer or distributor of the Products and shall maintain a reasonable (in Contractor's discretion) amount of the Products as "floor stock" as part of its business.

Product Inspection – All products are subject to inspection and testing prior to usage as set forth herein. A sample must be made available upon request.

Deliveries - Resulting deliveries are to be made FOB Destination - City of Port St. Lucie Utility Warehouse, 900 SE Ogden Lane, Port St. Lucie, Florida 34983 or as otherwise designated by the City of Port St. Lucie. All items are to be designated for inside delivery. Deliveries are received at this location between the hours of 8:00 am and 3:00 pm.

Delivery times shall be no later than the delivery times as stated below. Failure of the Contractor to meet this delivery requirement may result in default. It is hereby understood and mutually agreed to by and between the parties that the time of delivery is an essential condition of this contract.

Pumps that are not in stock locally, but within the United States shall be delivered within fifteen (15) business days of Contractor's receipt of order release.



Warranty Claim Pickup – Contractor shall pick up Products that do not conform to the Product specifications on Exhibit A within twenty (20) business days of receiving a warranty claim and written pickup request from the City.

Packing - All materials delivered as a result of this order are to be packed in a manner intended to ensure that the materials are not damaged in transit. A packing list specifying the City's contract number, quantity, description of each item shipped, and if the order is charged to Visa, the cardholder's name and card number shall accompany each shipment. The Contractor must have the capabilities of shrink-wrapping and palletizing individual loads as well as bulk truckloads.

Loading – Material is to be loaded suitable for removal from truck with driver assistance utilizing a pallet jack.

SECTION III **TERM**

As a continuing Single Source Contract, the original Contract period shall commence on _____, 2022 (the "Effective Date") and continue through _____, 2025, unless earlier terminated as set forth herein, with automatic renewal for additional one (1) year periods as set forth in Section IV below.

SECTION IV **RENEWAL OPTION**

The Contract period shall be for three (3) years and shall automatically renew for additional one (1) year periods unless either party notifies the other party in writing at least 90 days before the end of the then current term that the Contract will not be renewed.

SECTION V **COMPENSATION**

The City will pay to the Contractor a fixed per unit price for the Products and Services as listed in Exhibit "A" attached hereto, subject to adjustment as set forth herein. The City shall pay all invoices net forty-five (45) days from receipt of invoice unless Contractor has chosen to take advantage of the Purchasing Card Program, which guarantees payment within several days. Invoices shall be accompanied by adequate supporting documentation for approval by Project Manager. If City disputes any invoiced amounts, the City will promptly inform Contractor in writing of such dispute, the parties will work together to promptly resolve any such disputes, and the City shall pay all undisputed amounts when due.

All invoices and correspondence relative to this Contract must contain the Purchase Order number, Contract number, unique invoice number and details of items with prices that correspond to the Contract. All payments not made within the time specified by this section shall bear interest from thirty (30) calendar days after the due date at the rate of 1 percent per month on the undisputed, unpaid balance.

Beginning on the one-year anniversary of the Effective Date and thereafter on each successive anniversary of the Effective Date during the term and the beginning of each renewal term, prices for the Products and will increase by the greater of the US Department of Labor, Bureau of Labor Statistic Producers Price Index



(PPI), using the Pump and Pumping Equipment Manufacturing Index (BLS Series ID PCU333911333911) or 3%. Price adjustments calculated by the PPI method will use the US Department of Labor's recommendation of dividing the current index at the time of the price adjustment by the base index, taken on the date the latest pricing was quoted, and multiplying that number by the base or latest quoted price.

SECTION VI
WORK CHANGES

The City may request changes to an accepted order or order release. Any changes must be mutually agreed in writing by the parties, including any adjustments in the Contract price and time for completion. All changes must be authorized by a written change order signed by both parties. Work shall be changed and the Contract price and completion time shall be modified only as set out in the written change order. Any adjustment in the Contract price resulting in a credit or a charge to the City shall be determined by mutual agreement of the parties.

SECTION VII

N/A

SECTION VIII
INDEMNIFICATION/ HOLD HARMLESS

Contractor agrees to indemnify, defend and hold harmless, the City, its officers, agents, and employees from, and against any and all claims, actions, liabilities, losses and expenses (excluding attorney's fees) to the extent it involves third-party bodily injury, wrongful death, or loss of or damage to tangible property, at law or in equity, which may arise or may be alleged to have arisen from the negligent acts, errors, omissions or other wrongful conduct of Contractor, agents, laborers, subcontractors or other personnel entity acting under Contractor's control in connection with the Contractor's performance of services under this Contract.

SECTION IX
SOVERIEGN IMMUNITY

Nothing contained in this Contract shall be deemed or otherwise interpreted as waiving the City's sovereign immunity protections existing under the laws of the State of Florida, or as increasing the limits of liability as set forth in Section 768.28, Florida Statutes.

SECTION X
INSURANCE

The Contractor shall, on a primary basis and at its sole expense, agree to maintain in full force and effect at all times during the life of this Contract, insurance coverage, limits, including endorsements, as described herein. The requirements contained herein, as well as City's review or acceptance of insurance maintained by Contractor are not intended to and shall not in any manner limit or qualify the liabilities and obligations assumed by Contractor under the Contract.

The parties agree and recognize that it is not the intent of the City of Port St. Lucie that any insurance policy/coverage that it may obtain pursuant to any provision of this Contract will provide insurance coverage to any entity, corporation, business, person, or organization, other than the City of Port St. Lucie and the City shall not be obligated to provide any insurance coverage other than for the City of Port St. Lucie or



extend its sovereign immunity pursuant to Section 768.28, Florida Statutes, under its self-insured program. Any provision contained herein to the contrary shall be considered void and unenforceable by any party. This provision does not apply to any obligation imposed on any other party to obtain insurance coverage for this project, any obligation to name the City of Port St. Lucie as an additional insured under any other insurance policy, or otherwise protect the interests of the City of Port St. Lucie as specified in this Contract.

1. Workers' Compensation Insurance & Employer's Liability: The Contractor shall agree to maintain Workers' Compensation Insurance & Employers' Liability in accordance with Section 440, Florida Statutes. Employers' Liability and must include limits of at least \$100,000.00 each accident, \$100,000.00 each disease/employee, \$500,000.00 each disease/maximum. A Waiver of Subrogation endorsement shall be provided. Coverage shall apply on a primary basis. Should scope of work performed by Contractor qualify its employee for benefits under Federal Workers' Compensation Statute (example, U.S. Longshore & Harbor Workers Act or Merchant Marine Act), proof of appropriate Federal Act coverage must be provided.
2. Commercial General Liability Insurance: The Contractor shall agree to maintain Commercial General Liability insurance issued under an Occurrence form basis, including Contractual liability, to cover the hold harmless agreement set forth herein, with limits of not less than:

Each occurrence	\$1,000,000
Personal/advertising injury	\$1,000,000
Products/completed operations aggregate	\$2,000,000
General aggregate	\$2,000,000
Fire damage	\$100,000 any 1 fire

3. Additional Insured: An Additional Insured endorsement **must** be attached to the certificate of insurance (should be CG2026) under the General Liability policy. Coverage is to be written on an occurrence form basis. Coverage shall apply on a primary and non-contributory basis. Defense costs are to be in addition to the limit of liability. A waiver of subrogation shall be provided in favor of the City. Coverage shall extend to independent contractors, and fellow employees. Contractual Liability is to be included. Coverage is to include a cross liability or severability of interests' provision as provided under the standard ISO form separation of insurers clause.

Except as to Workers' Compensation and Employers' Liability, said Certificate(s) and policies shall clearly state that coverage required by the Contract has been endorsed to include the City of Port St. Lucie, a municipality of the State of Florida, its officers, agents and employees as Additional Insured added to its Commercial General Liability policy and Business Auto policy. The name for the Additional Insured endorsement issued by the insurer shall read **"City of Port St. Lucie, a municipality of the State of Florida, its officers, employees and agents and shall include Contract # 20210104 – Grinder Pumps and Parts shall be listed as additionally insured."** The Policies shall be specifically endorsed to provide thirty (30) day written notice to the City prior to any adverse changes, cancellation, or non-renewal of coverage thereunder. In the event that the statutory liability of the City is amended during the term of this Contract to exceed the above limits, the Contractor shall be required, upon thirty (30) days written notice by the City, to provide coverage at least equal to the amended statutory limit of liability of the City. Copies of the Additional Insured endorsements shall be attached to the Certificate of Insurance.



4. Automobile Liability Insurance: The Contractor shall agree to maintain Business Automobile Liability at a limit of liability not less than \$1,000,000.00 each accident covering any auto, owned, non-owned and hired automobiles. In the event, the Contractor does not own any automobiles; the Business Auto Liability requirement shall be amended allowing Contractor to agree to maintain only Hired & Non-Owned Auto Liability. This amended requirement may be satisfied by way of endorsement to the Commercial General Liability, or separate Business Auto Coverage form. Certificate holder must be listed as additional insured. A waiver of subrogation shall be provided. Coverage shall apply on a primary and non-contributory basis.
5. Waiver of Subrogation: The Contractor shall agree by entering into this Contract to a Waiver of Subrogation for each required policy. When required by the insurer, or should a policy condition not permit an Insured to enter into a pre-loss Contract to waive subrogation without an endorsement then Contractor shall agree to notify the insurer and request the policy be endorsed with a Waiver of Transfer of Rights of Recovery Against Others, or its equivalent. This Waiver of Subrogation requirement shall not apply to any policy where a condition to the policy specifically prohibits such an endorsement, or voids coverage should Contractor enter into such a Contract on a pre-loss basis.
6. Deductibles: All deductible amounts shall be paid for and be the responsibility of the Contractor for any and all claims under this Contract.

It shall be the responsibility of the Contractor to ensure that all independent contractors and/or subcontractors comply with the same insurance requirements referenced herein. It shall be the responsibility of the Contractor to obtain Certificates of Insurance from all contractors and sub-contractors listing the City as an Additional Insured without the language, when required by written contract.

The Contractor may satisfy the minimum limits required above for either Commercial General Liability, Business Auto Liability, or Employers' Liability coverage under Umbrella or Excess Liability. The Umbrella or Excess Liability shall have an Aggregate limit not less than the highest "Each Occurrence" limit for either Commercial General Liability, Business Auto Liability, or Employers' Liability. When required by the insurer, or when Umbrella or Excess Liability is written on Non-Follow Form," the City shall be endorsed as an "Additional Insured."

The City, by and through its Risk Management Department, reserves the right, but not obligation, to review, modify, reject, or accept any required policies of insurance including limits, coverages or endorsements, herein from time to time throughout the term of this contract. All insurance carriers must have an AM Best rating of at least A:VII or better.

A failure on the part of the contractor to execute the contract and/or punctually deliver the required insurance, and other documentation may be cause for annulment of the award.

SECTION XI
ACTS OF GOD

Not Applicable.



**SECTION XII
PERFORMANCE & PAYMENT BONDS**

N/A.

**SECTION XIII
PROHIBITION AGAINST FILING OR MAINTAINING LIENS AND SUITS**
Not applicable.

**SECTION XIV
COMPLIANCE WITH LAWS**

Contractor shall comply with all laws, rules, regulations, or ordinances applicable to the Products and the Services provided by Contractor pursuant to this Contract.

RECORDS

The City of Port St. Lucie is a public agency subject to Chapter 119, Florida Statutes. The Contractor shall comply with Florida's Public Records Law. CONTRACTOR'S RESPONSIBILITY FOR COMPLIANCE WITH CHAPTER 119, FLORIDA STATUTES. Pursuant to Section 119.0701, F.S.

Contractor agrees to comply with all public records laws, specifically to:

Keep and maintain public records required by the City in order to perform the service;

1. The timeframes and classifications for records retention requirements must be in accordance with the General Records Schedule GS1-SL for State and Local Government Agencies. (See <http://dos.dos.state.fl.us/library-archives/records-management/general-records-schedules/>).
2. During the term of the contract, the Contractor shall maintain all books, reports and records in accordance with generally accepted accounting practices and standards for records directly related to this contract. The form of all records and reports shall be subject to the approval of the City.
3. Records include all documents, papers, letters, maps, books, tapes, photographs, films, sound recordings, data processing software, or other material, regardless of the physical form, characteristics, or means of transmission, made or received pursuant to law or ordinance or in connection with the transaction of official business with the City. Contractor's records under this Contract include but are not limited to, subcontractor invoices and contracts, project documents, meeting notes, emails and all other documentation generated during this Agreement.
4. The Contractor agrees to make available to the City, during normal business hours all books of account, reports and records relating to this contract.
5. A Contractor who fails to provide the public records to the City within a reasonable time may also be subject to penalties under Section 119.10, Florida Statutes.

Upon request from the City's custodian of public records, provide the public agency with a copy of the requested records or allow the records to be inspected or copied within a reasonable time at a cost that does not exceed the cost provided in this chapter or as otherwise provided by law.



Ensure that public records that are exempt or confidential and exempt from public records disclosure requirements are not disclosed except as authorized by law for the duration of the contract term and following completion of the contract if the contractor does not transfer the records to the City.

Upon completion of the contract, transfer, at no cost to the City, all public records in possession of the Contractor, or keep and maintain public records required by the City to perform the service. If the Contractor transfers all public records to the City upon completion of the contract, the Contractor shall destroy any duplicate public records that are exempt or confidential and exempt from public records disclosure requirements. If the Contractor keeps and maintains public records upon completion of the contract, the Contractor shall meet all applicable requirements for retaining public records. All records stored electronically must be provided to the City, upon request from the City's custodian of public records in a format that is compatible with the information technology systems of the City.

IF THE CONTRACTOR HAS QUESTIONS REGARDING THE APPLICATION OF CHAPTER 119, FLORIDA STATUTES, TO THE CONTRACTOR'S DUTY TO PROVIDE PUBLIC RECORDS RELATING TO THIS CONTRACT, CONTACT THE CUSTODIAN OF PUBLIC RECORDS AT:

CITY CLERK
121 SW Port St. Lucie Blvd.
Port St. Lucie, FL 34984
(772) 871 5157
prc@cityofpsl.com

SECTION XV
DELIVERY DOCUMENTATION

Not applicable.

SECTION XVI
INSPECTION AND CORRECTION

In order to determine whether the Products have been delivered in accordance with the terms and conditions of the Contract documents, the Project Manager shall make inspection as soon as practicable after delivery. If such inspection shows that the Products have not been delivered in accordance with the terms and conditions of the Contract documents, the Project Manager shall promptly notify Contractor in writing providing reasonable detail regarding any issues with the delivered Products. Contractor shall then be afforded an opportunity to correct the deficiencies so pointed out at no additional charge to the City. Such examination, inspection, or tests made by the Project Manager, shall not relieve Contractor of its responsibility to remedy any non-conforming Products.



SECTION XVII
ADDITIONAL REQUIREMENTS

In the event of any conflict between the terms and conditions, appearing on any order form or order release issued relative to this Contract, and those contained in this Contract and the Product specifications herein referenced, the terms of this Contract and Product specifications herein referenced shall apply.

Disclaimer of Implied Warranties - This warranty is in lieu of all other warranties or obligations, express or implied. CONTRACTOR EXPRESSLY DISCLAIMS ALL IMPLIED WARRANTIES OF MERCHANTABILITY OR FITNESS FOR A PARTICULAR PURPOSE AND CONTRACTOR DOES NOT WARRANT THE ADEQUACY OF THE CITY'S DESIGNS OR SPECIFICATIONS OR THE INSPECTION PROTOCOL. No person is authorized to give any other warranties on Contractor's behalf.

Warranty - The Products will conform to the Product specifications set forth in Exhibit A as determined and demonstrated by the then in effect inspection methods and standards. If the Products do not conform to the stated warranty, Contractor will, as the City's sole and exclusive remedy, either rework, replace, or compensate the City for Contractor-authorized repair of the Products that are agreed to be non-conforming. The warranty provisions herein will not apply if (i) the Products were rejected by the use or application of test or inspection procedures or processes not agreed to by the Contractor; or (ii) the City (or its subcontractors or agents) has or has attempted to correct, repair, rework or otherwise alter the goods without Contractor's prior written authorization. The warranty period shall last for three hundred sixty-five (365) calendar days after installation or 455 calendar days after shipment, whichever occurs first

Miscellaneous Testing - The Contractor agrees to reimburse the City for any reasonable expenditure incurred by the City for the performance of mutually agreed testing of the Products supplied by the Contractor if said Products prove to be not in compliance with the Product specifications in Exhibit A.

Standard Production Items - All products offered must be standard production items that have been available to the trade for a period of not less than two (2) years and are expected to remain available in future years.

SECTION XVIII
LICENSING

N/A.

SECTION XIX
SAFETY PRECAUTIONS

Conditions for Emergency/Hurricane or Disaster It is hereby made part of the Contract that before and after a public emergency, disaster, hurricane, flood or other such acts of God that the city of Port St. Lucie shall require "priority" basis for goods and services. It is vital and imperative that the majority of citizens are protected from any emergency situation which threatens public health and safety as determined by the City. Contractor agrees to rent/sell/lease all goods and service to the city or other government entities as opposed or a private citizen on a priority basis. The City expects to pay contractual prices for all goods and services required during and emergency situation. The Contractor shall furnish a twenty-four (24) hour phone number in the event of such an emergency.



SECTION XX
ASSIGNMENT

Contractor shall not delegate, assign or subcontract any part of the work required to be performed under this Contract or assign any monies due Contractor hereunder without first obtaining the written consent of the City. The City shall not assign this Contract without first obtaining the written consent of the Contractor.

SECTION XXI
TERMINATION AND EXCUSABLE DELAYS

Termination for Cause. If either the City or Contractor breaches any material provision hereof, the other party will have the right to terminate hereunder if the breaching party fails to cure its breach (other than a failure by the City to pay any amount when due, which failure will have no cure period) within 30 days after receiving written notice from the other party. If the breaching party reasonably requires more than 30 days to cure its breach, the 30-day cure period will be extended as reasonably necessary to allow completion of the cure, provided that the breaching party begins the cure within the 30-day period and diligently pursues the cure to completion. In addition, a party shall have the right to terminate if the other party becomes subject to any bankruptcy or insolvency proceeding under federal or state law to the extent allowed by applicable federal or state law including bankruptcy laws or a party reasonably believes that the other party has become insolvent or unable to pay its obligations as they accrue consistent with applicable federal or state law.

Excusable Delays. Contractor will not be responsible for any failure, interruption or delay in manufacture or delivery that is related to: (1) any acts of the Federal Government, including controls or restrictions or requisitioning of materials, equipment, tools or labor by reason of war, national defense or any other national emergency, (2) any acts of the City or of any other State or local government which prevent performance or make performance impractical, (3) causes that are beyond the control of the Contractor which prevent performance or make performance impractical, including but not restricted to, acts of God, acts of the public enemy, acts of another contractor in the performance of some other contract with the City, fires, floods, pandemics, epidemics, quarantine, strikes, freight embargoes and weather of unusual severity such as hurricanes, tornadoes, cyclones and other extreme weather conditions, and/or (4) any delay of any Subcontractor occasioned by any of the above mentioned causes. However, the Contractor must promptly notify the City in writing of the cause of delay. The City shall extend the time for completing the work for a period of time commensurate with the period of excusable delay.

SECTION XXII
LAW AND VENUE

This Contract is to be construed as though made in and to be performed in the State of Florida and is to be governed by the laws of Florida in all respects without reference to the laws of any other state or nation. The venue of any action taken to enforce this Contract shall be in St. Lucie County, Florida.

SECTION XXIII

Not Applicable.



SECTION XXIV
APPROPRIATION APPROVAL

The Contractor acknowledges that the City of Port St. Lucie's performance and obligation to pay under this Contract is contingent upon an annual appropriation by the City Council. The Contractor agrees that, in the event such appropriation is not forthcoming, the City may terminate this Contract by providing at least 120 days advance notice in writing and that no charges, penalties or other costs shall be assessed. For clarity, the City will be responsible for paying for Products and Services provided prior to the effective date of any such termination.

SECTION XXV
ATTORNEY'S FEES

Each party agrees to pay its own attorneys' fees and costs.

SECTION XXVI
CODE OF ETHICS

Contractor warrants and represents that its employees will abide by the Precision Castparts Corp. Code of Conduct, a copy of which can be found at this website: <https://www.precast.com/public-relations/code-of-conduct.pdf>. For any Services performed in Florida, Contractor warrants and represents that its employees will abide by any applicable provisions of the State of Florida Code of Ethics found in Chapter 112.311 et seq., Florida Statutes.

SECTION XXVII
POLICY OF NON-DISCRIMINATION

Contractor shall not discriminate against any person in its operations, activities or delivery of services under this Contract. Contractor shall affirmatively comply with all applicable provisions of federal, state and local equal employment laws and shall not engage in or commit any discriminatory practice against any person based on race, age, religion, color, gender, sexual orientation, national origin, marital status, physical or mental disability, political affiliation or any other factor which cannot be lawfully used as a basis for service delivery.

SECTION XXVIII
SEVERABILITY

The Parties to this Contract expressly agree that it is not their intention to violate any public policy, statutory or common law rules, regulations, or decisions of any governmental or regulatory body. If any provision of this Contract is judicially or administratively interpreted or construed as being in violation of any such policy, rule, regulation, or decision, the provision, sections, sentence, word, clause, or combination thereof causing such violation will be inoperative (and in lieu thereof there will be inserted such provision, section, sentence, word, clause, or combination thereof as may be valid and consistent with the intent of the Parties under this Contract) and the remainder of this Contract, as amended, will remain binding upon the Parties, unless the inoperative provision would cause enforcement of the remainder of this Contract to be inequitable under the circumstances.



SECTION XXIX
MUTUAL WAIVER AND LIMITATION OF LIABILITY

City and Contractor (inclusive of their respective officers, directors, members, partners, subcontractors, and employees) shall not be liable to each other for loss or profit or revenue, loss of use or business opportunity, loss of contract, cost of obtaining alternative performance, or for any indirect, consequential, special, incidental and punitive damages; provided, however that this limitation of liability shall not apply to any claim by either party against the other party for fraud, willful misconduct, or breach of confidentiality obligations. The aggregate liability of each party, whether under contract law, in tort, or otherwise, will not exceed the total amount paid to the Contractor by the City in the twelve (12) months prior to the filing of the relevant dispute ("Cap"). The Cap does not apply or limit any claim by the City against the Contractor pursuant to Section VIII or any claim by either party against the other party for fraud or willful misconduct. The rights and remedies of the parties herein are cumulative and in addition to any and all rights and remedies by law, equity or otherwise; however, to the extent the Contract provides a remedy for a given default, it is the sole and exclusive remedy available in lieu of any/all other remedies available at law, in equity, or otherwise.

SECTION XXXX
ENTIRE CONTRACT

The written terms and provisions of this Contract shall take precedence over any and all prior and contemporaneous verbal or written statements of any official or other representative of the City. Any such statements shall not be effective or be construed as entering into, or forming a part of, or altering in any manner whatsoever, this Contract or Contract documents.

(Balance of page left intentionally blank)



Exhibit A:



Environment One Corp. - 2773 Balltown Road - Niskayuna, NY 12309
 Phone: (518) 346-6161 Fax: (518) 346-4382

QUOTATION

Number: 1-23-22
 Revision: -
 Revision Date: N/A

Thank you for your interest in Environment One, its products and services.
 We are pleased to offer this quotation for your consideration.

To: City of Port St. Lucie - Utility Systems Department 900 SE Ogdan Ln Port St. Lucie FL, 34983	ORIGINAL DATE	1/23/2022
	REFERENCE	Truckload E/One Grinder Systems
Attn: Tim Richards Administrator, Water Distribution & Wastewater Collections Utility Systems Department		
Project: PSL-USD/Port St. Lucie FL, 34983		

Items	Unit	Quantity	Unit Price	Total Price
1 E/One Grinder Pump Core Unit, Sentry Panel and Extended Warranty	EA	4,840	\$ 1,418.00	\$ 6,863,120.00
Above Includes:				
Cable				
SB1F000B0AA - SENTRY SIM-CON,240V,2P,GEN,NO LOCK				
PA0558P07 - Grommet, 3"				
N/A0043P03- Pump Core Warranty, 5 YEARS				
2 E/One Upgrade (PM) Unit, Sentry Panel & Extended Warranty				
Above Includes:				
Cable	EA	3,000	\$ 1,150.00	\$ 3,450,000.00
SB1F000B0UP - SENTRY SIM-CON,240V,2P,GEN,NO LOCK, UPGRADE/PM	EA	3,000	\$ 268.00	\$ 804,000.00
N/A0043P03- Pump Core Warranty, 5 YEARS				\$ -
Complete Residential Station:				
Cable	EA	1	\$ 1,150.00	\$ 1,150.00
SB1F000B0AA - SENTRY SIM-CON,240V,2P,GEN,NO LOCK	EA	1	\$ 550.00	\$ 550.00
W001B02C99T -WH101-52, HDPE Tank, Standard Cover w/Integrated Vent	EA	1	\$ 600.00	\$ 600.00
N/A0043P03- Pump Core Warranty, 5 YEARS				
FACTORY Tank Warranty 10 YEARS				
3 Larger Residential Tank:				
W001N41C01T-WT231 HDPE Tank, 237 Gallon, w/Flat Cover & Field Installed Inlet	EA	1	\$ 1,107.00	\$ 1,107.00
4 Stainless Steel Unilateral				
NC0193G01 - Curb Stop Kit, Stainless Steel, 1-1/4" Compression Fittings for SDR 11	EA	1	\$ 158.00	\$ 158.00
5 Spare Parts:				
Stator/Liner Assembly - NC0039G01	EA	60	\$ 88.99	\$ 5,339.40
INLET SHROUD, EXTREME - ND0004P01	EA	5	\$ 10.95	\$ 54.75
Motor Controller Board - NB0494G01	EA	10	\$ 243.46	\$ 2,434.60
ALARM REPLACEMENT PC BOARD, SIMPLEX SENTRY, 240/120 - PB0939G21	EA	10	\$ 236.67	\$ 2,366.70
LENS AND GASKET ASSEMBLY, SENTRY - PA2138G01	EA	5	\$ 34.69	\$ 173.45
Pressure Switch, Alarm - NB0083G02	EA	40	\$ 65.70	\$ 2,628.00
Pressure Switch, On/Off - NB0083G01	EA	40	\$ 65.70	\$ 2,628.00
TERMINAL, FLAG, FLAG, 22-18GA, RED - PA0491P01	EA	200	\$ 1.24	\$ 248.00
SEAL, LEVEL SENSING HOUSING, EXTREME - NB0042P02	EA	40	\$ 3.74	\$ 149.60
Motor Housing Assembly - NC0036G01	EA	10	\$ 382.18	\$ 3,821.80
WASHER, WAVE SPRING, (2000, EXTREME) - PA1010P01	EA	3	\$ 2.16	\$ 6.48
BEARING, PUMP END - PA0109P01	EA	15	\$ 36.83	\$ 552.45
BEARING, TOP - PA1181P01	EA	15	\$ 80.89	\$ 1,213.35
NUT, STOP (ELASTIC) 5/16-18 - Part # 0719-3218SS	EA	200	\$ 1.15	\$ 230.00
CORD GRIP, 1/2 INCH NPT W/ O-RING - NA0045G02	EA	10	\$ 15.06	\$ 150.60
Cutter Wheel, Machined - NC0008P02	EA	15	\$ 123.23	\$ 1,848.45
Level Sensor Housing, Alarm - ND0013P08	EA	12	\$ 44.50	\$ 534.00
Level Sensor Housing, On/Off - ND0012P07	EA	12	\$ 52.25	\$ 627.00
Rotor, Pump, Machined and Polished - PC0054P02	EA	12	\$ 180.67	\$ 2,168.04
GROOVE PIN, 5/32 INCH D, 1 INCH LG - 0721-E058	EA	5	\$ 0.78	\$ 3.90
EQD Assembly, Core Side - ND0037G01	EA	15	\$ 122.30	\$ 1,834.50
EQD Assembly, Supply Cable Side - ND0036G01	EA	15	\$ 86.53	\$ 1,297.95
Mechanical Seal Kit - NC0040G01	EA	15	\$ 55.60	\$ 834.00
HOSE FLEX DISCHARGE KIT - PC0542G01	EA	5	\$ 163.47	\$ 817.35
6 Tools & Test Equipment & Chemicals:				
HAND PUMP, VACUUM/PRESS - PA1019G01	EA	1	\$ 275.89	\$ 275.89
FITTING/ADAPTER, 1/8NPT X 3/16 BARB (CONTROL CAVITY TEST) - NA0219P06	EA	2	\$ 3.42	\$ 6.84
MOTOR AIR TEST FIXTURE - PA1198P01	EA	2	\$ 22.94	\$ 45.88
LOCTITE 641, 10 mL, BEARINGS - 0323-049	EA	2	\$ 33.29	\$ 66.58
LOCTITE 598, 0.5 OZ, CABLE ENTRY - NA0161P02	EA	5	\$ 11.25	\$ 56.25
SILICONE, MOLYCOTE 55, 5.3 OZ - NA0008P02	EA	3	\$ 52.43	\$ 157.29
GREASE, SILICONE, 5.3 OZ - Part # 0302-005	EA	3	\$ 34.81	\$ 104.43
TOTAL				\$ 11,153,360.53

ITEMS INCLUDED IN ABOVE PRICING:

- All pumps include 32' cables
- Submittals
- Delivery to Jobsite in Truckload Quantities per FREIGHT Item below
- Warranty - Per E/One's standard Limited Warranty for a period as described above from start up date

ITEMS NOT INCLUDED:

- Installation, field piping, field wiring, concrete ballast, taxes of any kind or type, nor any item not specifically included in this proposal

E/ONE STANDARD TERMS FOR PSL ARE ATTACHED:

- Net 30 days from the date of invoice at time of shipment. Environment One's standard Terms and Conditions are attached and are considered to be part of this quotation proposal

FREIGHT:

- FOB Destination, Freight Prepaid and Allowed in Truckload Quantities (200 Pump Cores per Truckload)

DELIVERY:

- 4 Weeks ARO

VALIDATION:

- This proposal is valid for 30 days from date above

On Behalf of Environment One Corp.

Chris Nedwick
 cnedwick@eone.com
 (518) 596-2186

U.S. export control laws apply to the products and technologies covered by this quotation. Export or re-export of these products or technologies may require the prior approval of the U.S. government in accordance with the Export Administration Regulations, and OFAC rules, and customer agrees to notify Environment One Corporation, Inc. of any such intended export or re-export. Diversion contrary to U.S. law is prohibited.

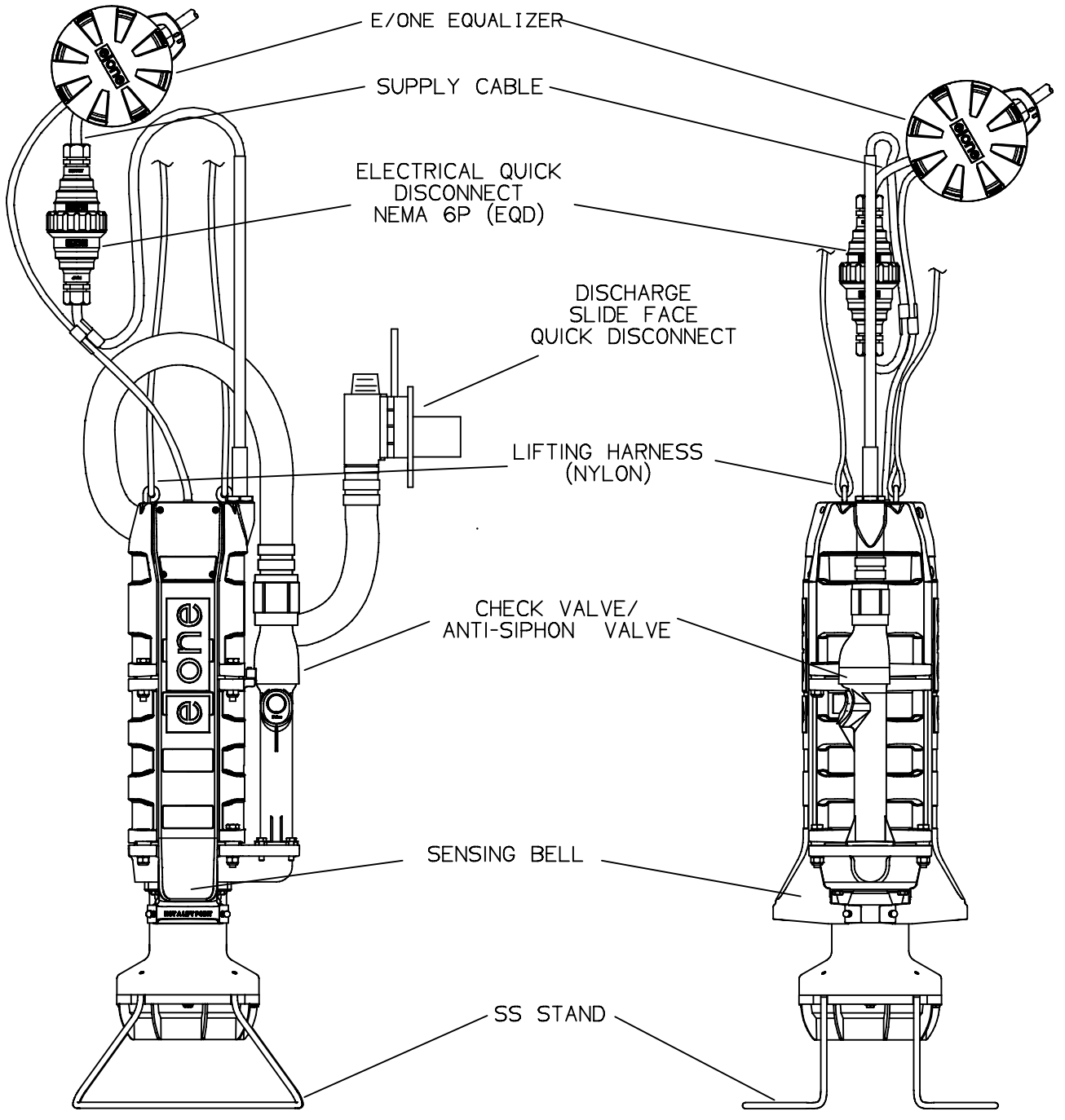

W SERIES GRINDER PUMP



SGS		06/14/12	2	
DR BY	CHK'D	DATE	ISSUE	SCALE



W-SERIES FEATURES

ESD 08-0027

NOTE: SLIDE FACE RECEIVER IS MOUNTED IN TANK WALL ON W-SERIES

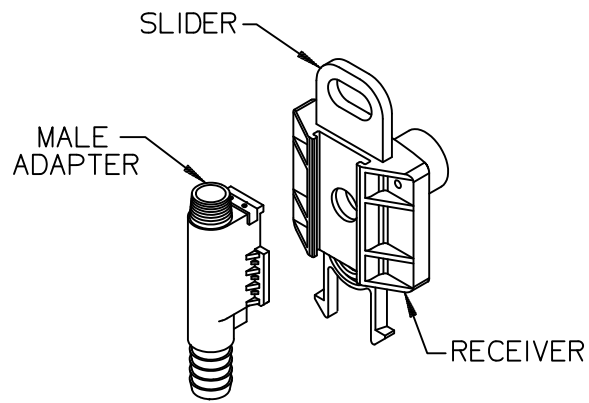
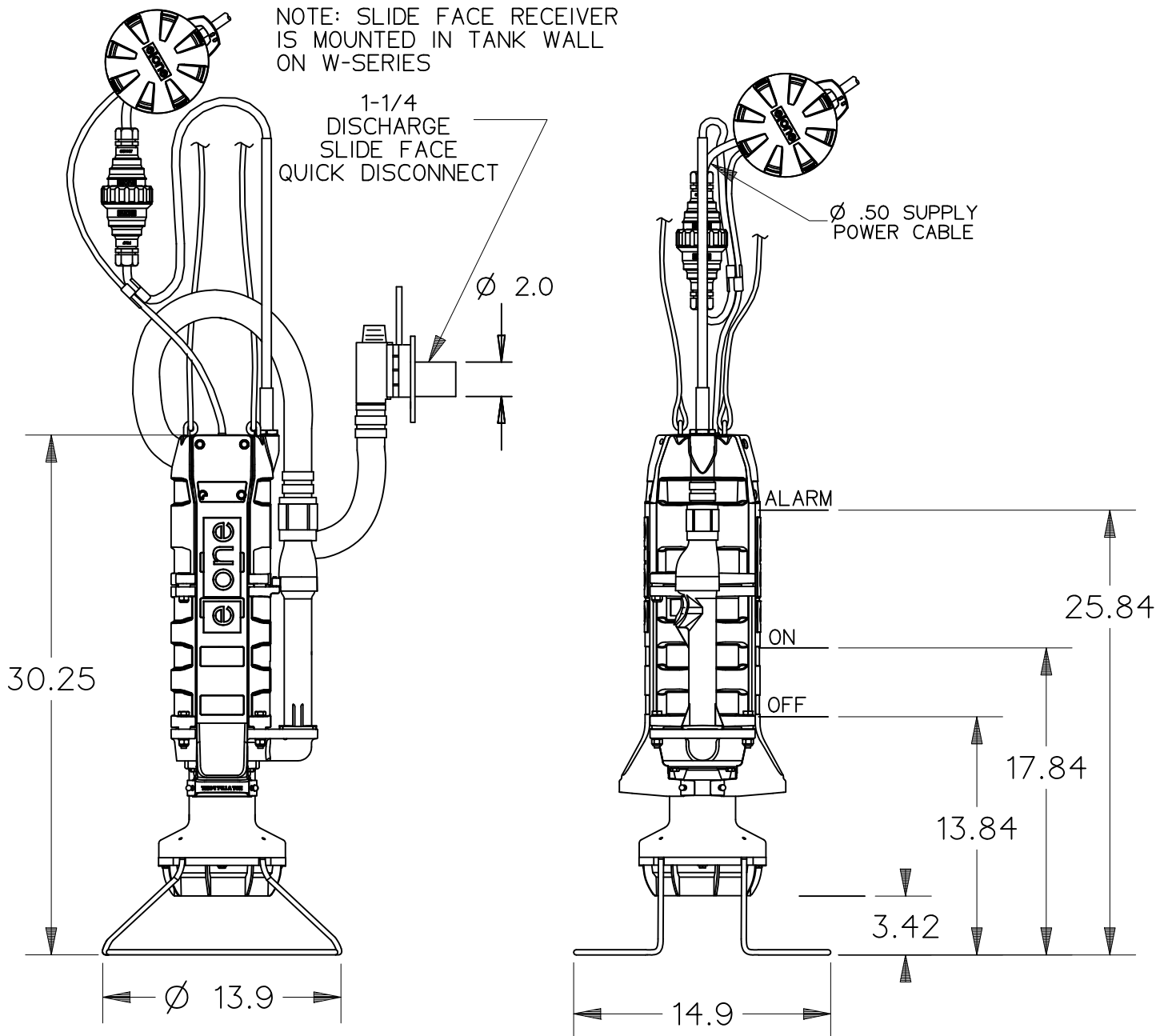

SLIDE FACE DISCHARGE COMPONENTS

W SERIES GRINDER PUMP



SGS		05/30/18	2	
DR BY	CHK'D	DATE	ISSUE	SCALE



DIMENSION SHEET
W SERIES PUMP

ESD 09-0060

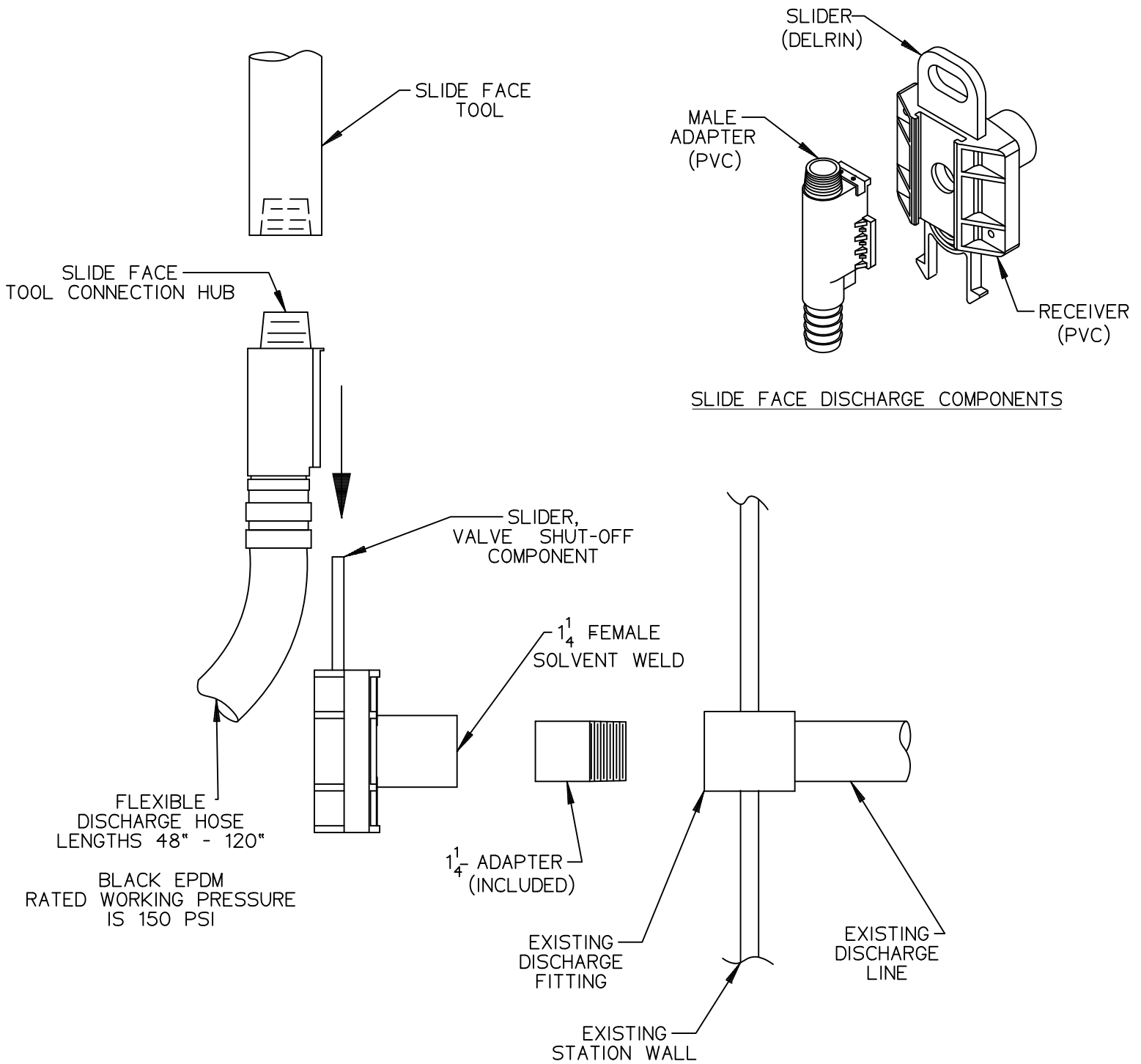

SLIDE FACE ASSEMBLY

SGS		08/30/18	5	1/16
DR BY	CHK'D	DATE	ISSUE	SCALE



SLIDEFACE DISCHARGE DETAIL

ESD 09-0136

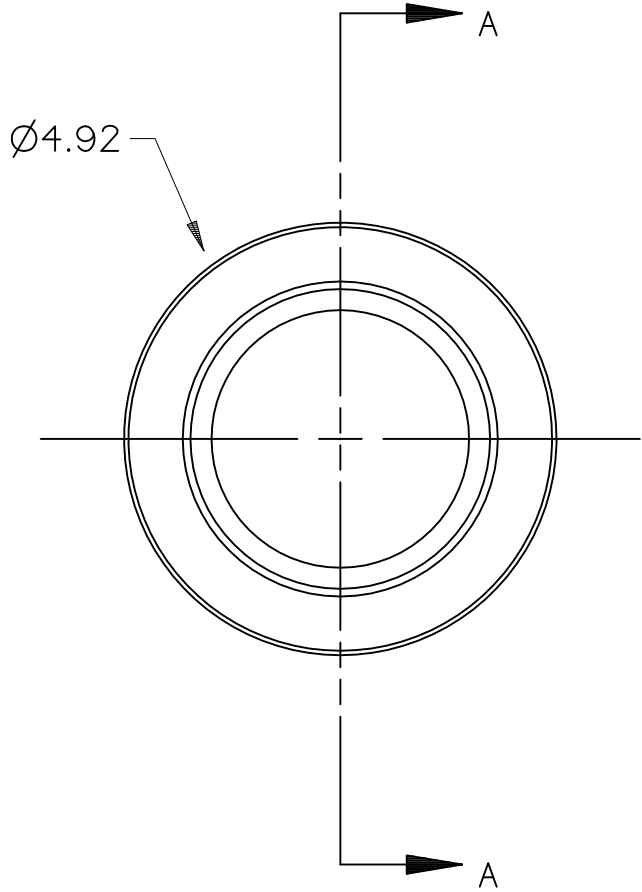
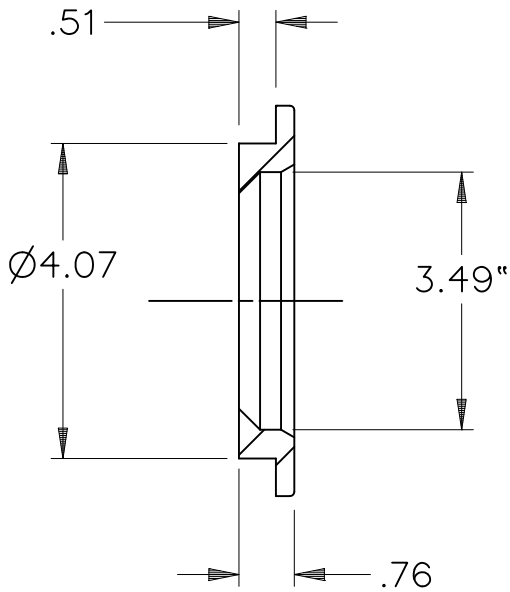

SECTION "A-A"

1. MATERIAL: EPDM, COLOR: BLACK
75 +/- 10 SHORE A DUROMETER
2. FOR USE WITH 3" DWV PIPE

PART No. PA0558P07

SGS		02/11/22	1	3/8
DR BY	CHK'D	DATE	ISSUE	SCALE

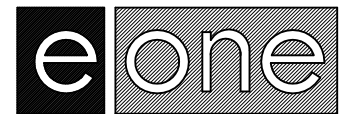

SEWER SYSTEMS

INLET GROMMET,
3" DWV, EPDM

ESD 22-0006

WH101/WR101

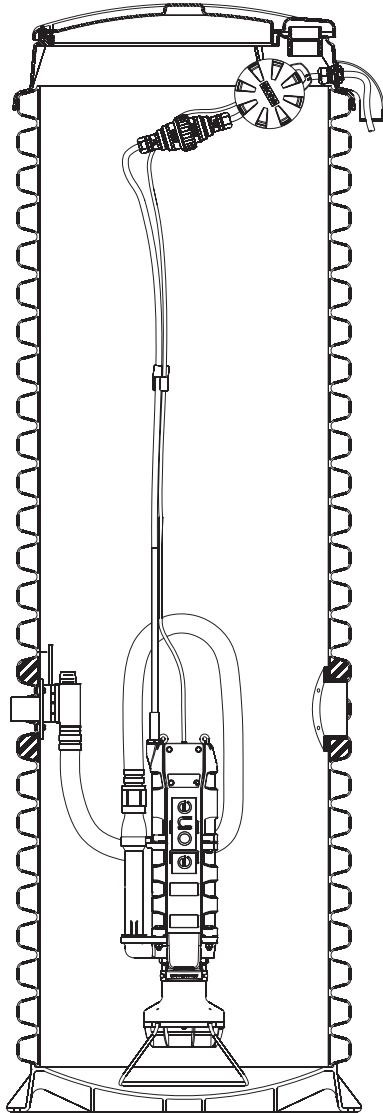

General Features

The model WH101 or WR101 grinder pump station is a complete unit that includes: the grinder pump, check valve, HDPE (high density polyethylene) tank, controls, and alarm panel. A single WH101 or WR101 can accommodate the sewage flow from two, average single-family homes.

- Rated for flows of 700 gpd (2650 lpd)
- 70 gallons (265 liters) of capacity
- Standard outdoor heights range from 60 inches to 159 inches

The WH101 is the “hardwired,” or “wired,” model where a cable connects the motor controls to the level controls through watertight penetrations.

The WR101 is the “radio frequency identification” (RFID), or “wireless,” model that uses wireless technology to communicate between the level controls and the motor controls.

Operational Information

Motor

1 hp, 1,725 rpm, high torque, capacitor start, thermally protected, 120/240V, 60 Hz, 1 phase

Inlet Connections

4” PVC inlet flange for Schedule 40 pipe

Discharge Connections

Pump discharge terminates in 1.25-inch NPT female thread. Can easily be adapted to 1.25-inch PVC pipe or any other material required by local codes.

Discharge

15 gpm at 0 psig (0.95 lps at 0 m)
11 gpm at 40 psig (0.69 lps at 28 m)
7.8 gpm at 80 psig (0.49 lps at 56 m)

Accessories

E/One requires that the Uni-Lateral, E/One’s own stainless steel check valve, be installed between the grinder pump station and the street main for added protection against backflow.

Alarm panels are available with a variety of options, from basic monitoring to advanced notice of service requirements.

The Remote Sentry is ideal for installations where the alarm panel may be hidden from view.

Patent Numbers: 5,752,315
5,562,254 5,439,180

WH101-52

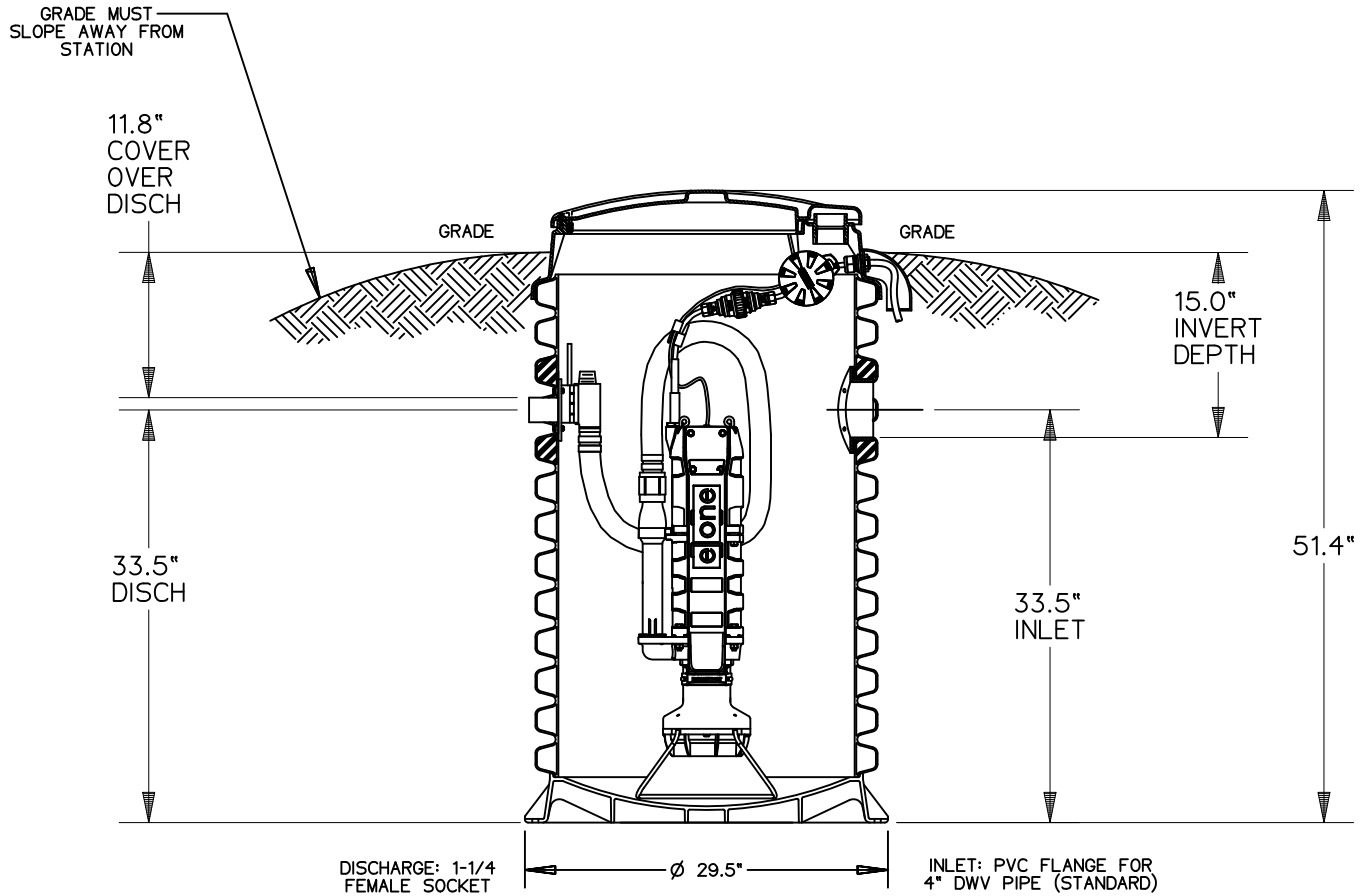

SEE INSTALLATION INSTRUCTIONS
FOR BALLAST REQUIREMENTS



SGS		02/08/17	2	
DR BY	CHK'D	DATE	ISSUE	SCALE



MODEL WH101-52

ESD 10-0021

WH231/WR231

General Features

The model WH231 or WR231 grinder pump station is a complete unit that includes: the grinder pump, check valve, polyethylene tank, controls, and alarm panel. The lower portion of the tank has a smaller diameter, tapered down to a dish-shaped bottom. These design features reduce the retained volume and promote scouring, which will minimize odor and corrosiveness.

- Rated for flows of 850 gpd (3218 lpd)
- 237 gallons (874 liters) of capacity
- Standard outdoor heights range from 55 inches to 92 inches

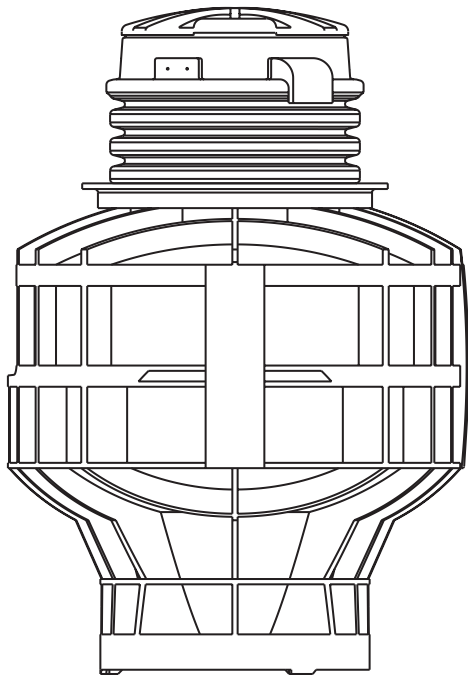

The WH231 is the “hardwired,” or “wired,” model where a cable connects the motor controls to the level controls through watertight penetrations.

The WR231 is the “radio frequency identification” (RFID), or “wireless,” model that uses wireless technology to communicate between the level controls and the motor controls.

Operational Information

Motor

1 hp, 1,725 rpm, high torque, capacitor start, thermally protected, 120/240V, 60 Hz, 1 phase

Inlet Connections

4-inch inlet grommet standard for DWV pipe. Other inlet configurations available from the factory.

Discharge Connections

Pump discharge terminates in 1.25-inch NPT female thread. Can easily be adapted to 1.25-inch PVC pipe or any other material required by local codes.

Discharge

15 gpm at 0 psig (0.95 lps at 0 m)
11 gpm at 40 psig (0.69 lps at 28 m)
7.8 gpm at 80 psig (0.49 lps at 56 m)

Accessories

E/One requires that the Uni-Lateral, E/One’s own stainless steel check valve, be installed between the grinder pump station and the street main for added protection against backflow.

Alarm panels are available with a variety of options, from basic monitoring to advanced notice of service requirements.

The Remote Sentry is ideal for installations where the alarm panel may be hidden from view.

OPTIONS : **WH231-55** (HARD WIRED LEVEL CONTROLS)
 WR231-55 (WIRELESS LEVEL CONTROLS)

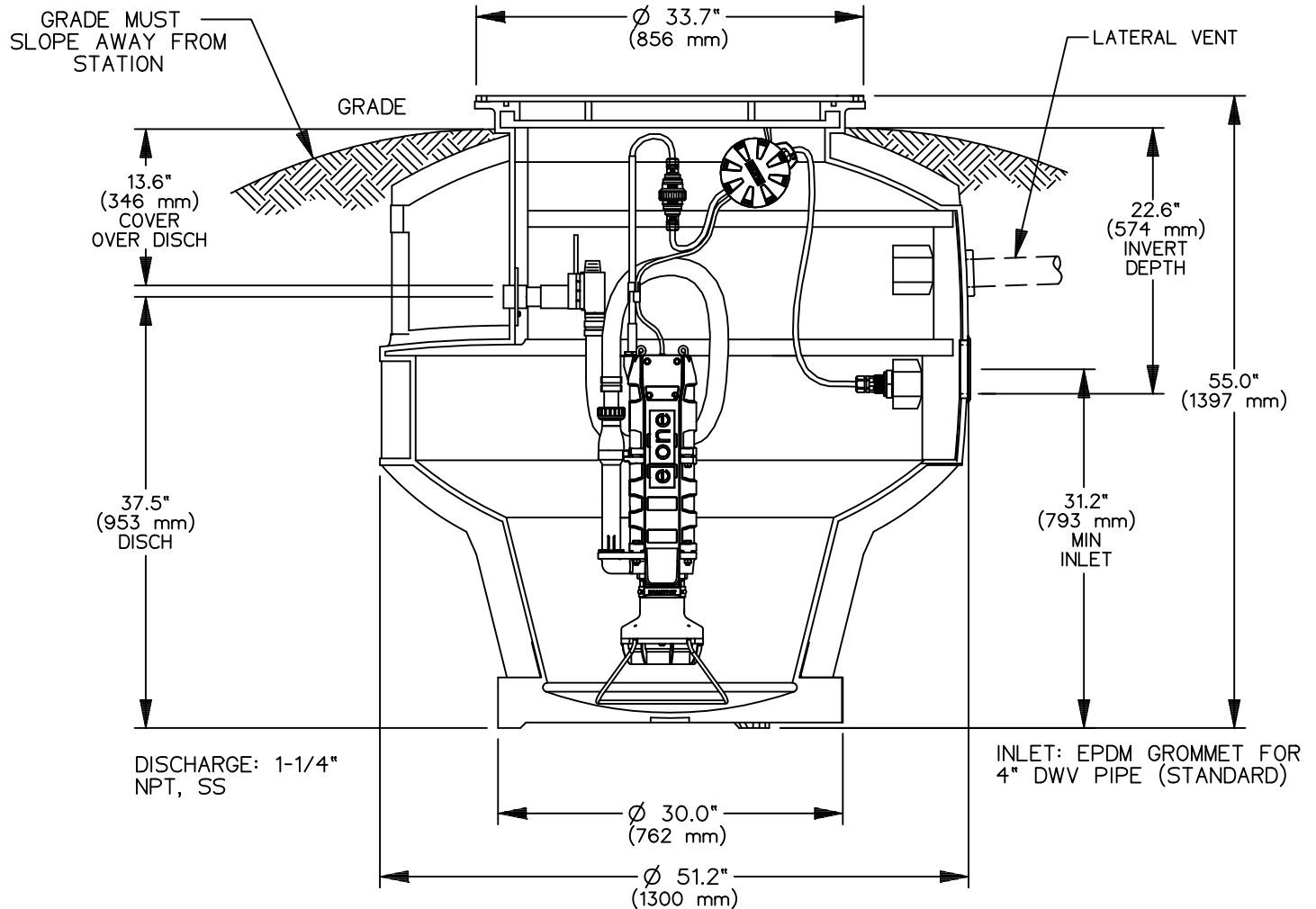

CONCRETE BALLAST MAY BE REQUIRED
 SEE INSTALLATION INSTRUCTIONS
 FOR DETAILS

NOTE: DIMENSIONS ARE FOR REF ONLY

AD	SGS	12/23/10	E	
DR BY	CHK'D	DATE	ISSUE	SCALE



MODEL WH231-55 / WR231-55

NA0059P03

E/One Sentry™

Alarm Panel — Basic Package

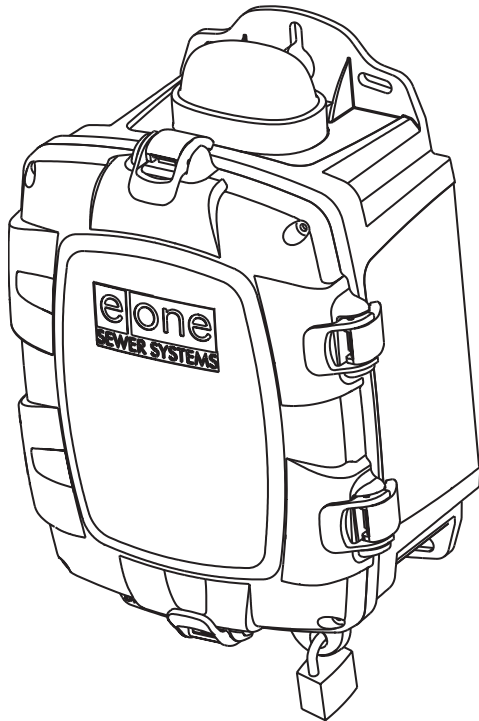

Description

The E/One Sentry panels are custom designed for use with Environment One grinder pump stations. They can be configured to meet the needs of your application, from basic alarm indication to advanced warning of pending service requirements.

E/One Sentry panels are supplied with audible and visual high level alarms. They are easily installed in accordance with relevant national and local codes. Standard panels are approved by UL, CSA, CE and NSF to ensure high quality and safety.

The panel features a corrosion-proof, NEMA 4X-rated, thermoplastic enclosure. A padlock is provided to prevent unauthorized entry (safety front).

Standard Features

- Circuit breakers, 240 or 120 VAC service
- Terminal blocks and ground lugs
- Audible alarm with manual silence
- Manual run feature and run indicator
- Redundant "Start" function with high level alarm
- Conformal-coated alarm board (both sides)
- Alarm board overload protection

Optional Features

- Contact group (dry, powered and Remote Sentry)
- Inner cover (dead front)
- Hour meter
- Generator receptacle with auto transfer
- GFCI
- Main service disconnect
- Brownout protection

Please consult factory for special applications.

SIMPLEX SENTRY

REDUNDANT RUN (HIGH LEVEL)
 EXTERNAL VISUAL & AUDIBLE ALARM
 EXTERNAL LATCHING MANUAL SILENCE
 MANUAL RUN
 PUMP RUN INDICATOR
 CONFORMAL COATED CIRCUIT BOARD
 PADLOCK
 NEMA 4X ENCLOSURE ASSEMBLY
 CORROSION PROOF THERMOPLASTIC
 POLYESTER APPROVED BY UL FOR
 ELECTRICAL CONTROL ENCLOSURE

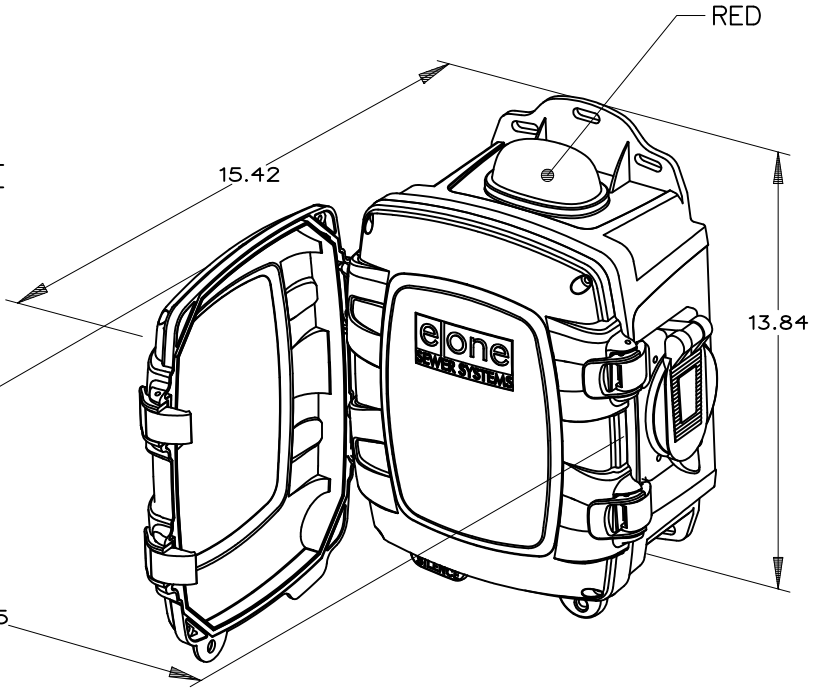

OPTIONS:

- ALARM CONTACTS
- GENERATOR RECPT

PANEL SHOWN IS:
 SB1F000B0AA

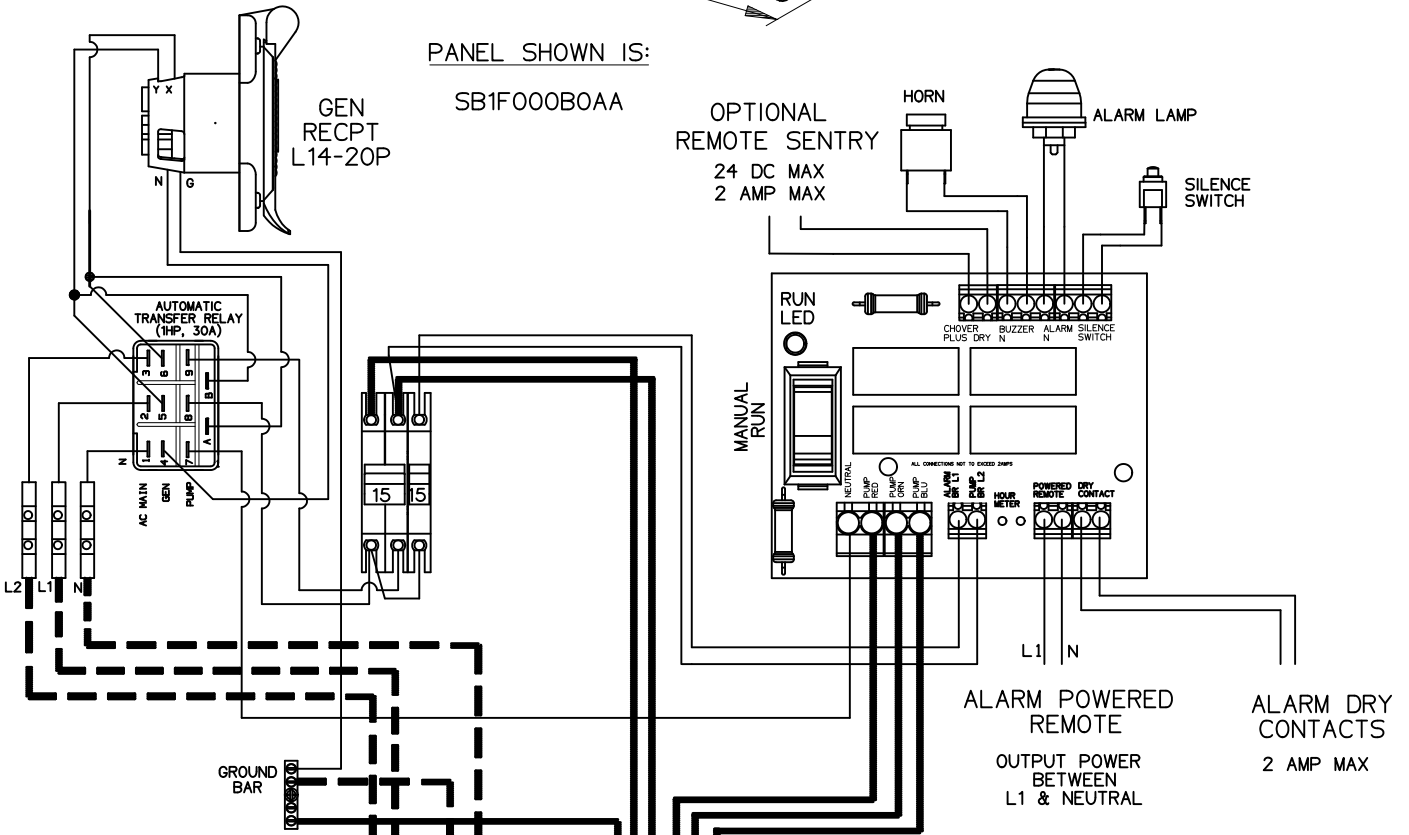

--- SUPPLIED BY OTHERS
 ——— SUPPLY CABLE (FROM PUMP)
 - - - - - POSSIBLE OPTION
 ——— FACTORY WIRED

PIN	FUNCTION	2000S	EXTREME
1	MANUAL RUN	RED	BROWN
2	L1	BLACK	RED
3	L2	WHITE	BLACK
4	GND	GREEN	GRN/YEL
5	ALARM FEED	ORANGE	YELLOW
6	ALARM RETURN	BLUE	BLUE

CONTROL CABLE:
 TYPE TC: DIRECT BURIAL, 12AWG,
 SIX CONDUCTOR



SGS		02/11/22	1	N/A
DR BY	CHK'D	DATE	ISSUE	SCALE



SIMPLEX SENTRY, 240V
 CONTACTS, GEN RECPT, NO LOCK

ESD 22-0005

STAINLESS STEEL LATERAL KIT 1-1/4" SDR 11 HDPE PIPE

NOTE: CURB BOX NOT USED OR BY OTHERS

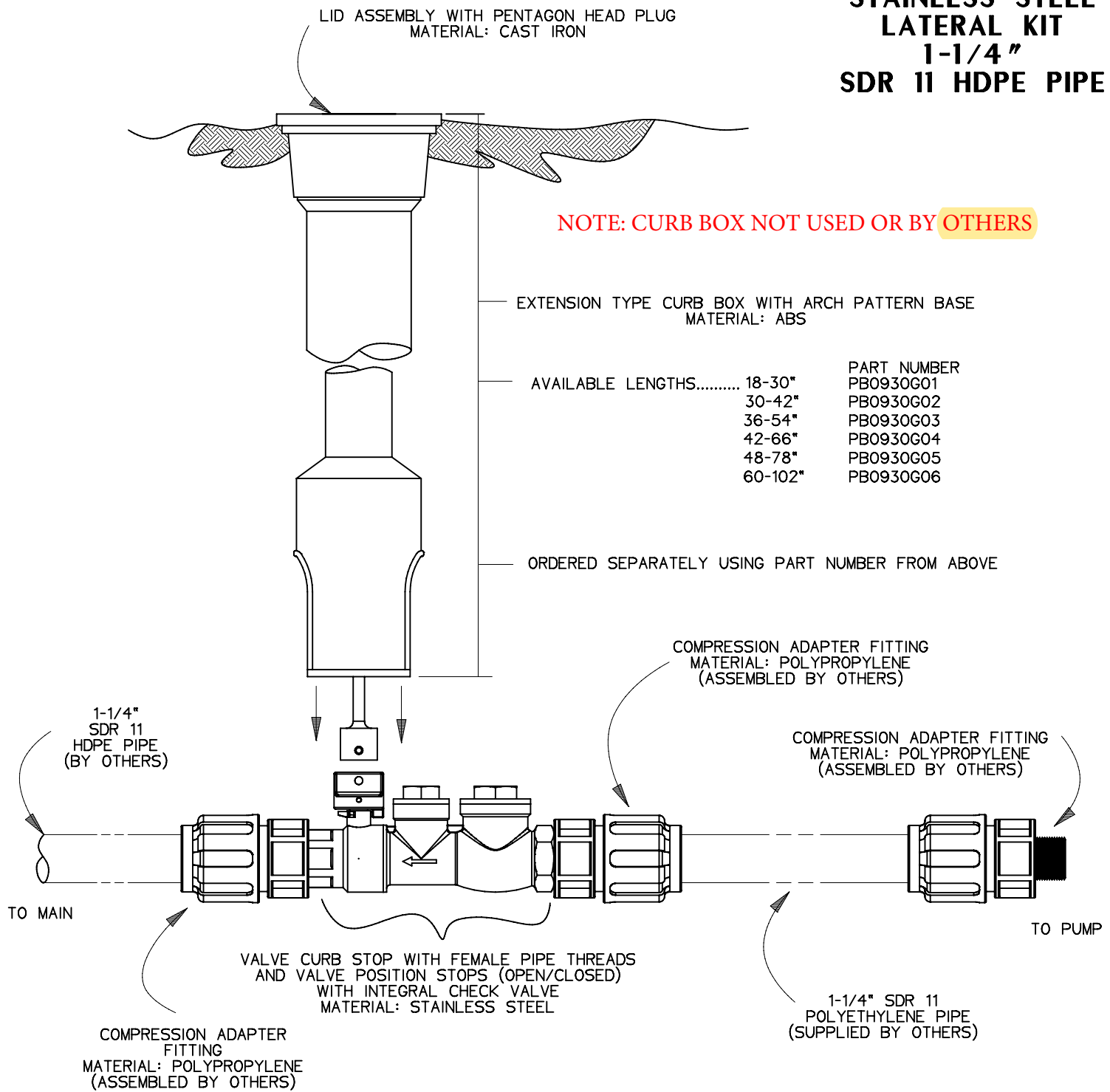

EXTENSION TYPE CURB BOX WITH ARCH PATTERN BASE
MATERIAL: ABS

AVAILABLE LENGTHS.....	18-30"	PART NUMBER	PB0930G01
	30-42"		PB0930G02
	36-54"		PB0930G03
	42-66"		PB0930G04
	48-78"		PB0930G05
	60-102"		PB0930G06

ORDERED SEPARATELY USING PART NUMBER FROM ABOVE

COMPRESSION ADAPTER FITTING
MATERIAL: POLYPROPYLENE
(ASSEMBLED BY OTHERS)

COMPRESSION ADAPTER FITTING
MATERIAL: POLYPROPYLENE
(ASSEMBLED BY OTHERS)

1-1/4"
SDR 11
HDPE PIPE
(BY OTHERS)

TO MAIN

TO PUMP

VALVE CURB STOP WITH FEMALE PIPE THREADS
AND VALVE POSITION STOPS (OPEN/CLOSED)
WITH INTEGRAL CHECK VALVE
MATERIAL: STAINLESS STEEL

COMPRESSION ADAPTER
FITTING
MATERIAL: POLYPROPYLENE
(ASSEMBLED BY OTHERS)

1-1/4" SDR 11
POLYETHYLENE PIPE
(SUPPLIED BY OTHERS)

KIT PARTS ARE NOT ASSEMBLED

NOTES:

1. SS CURB STOP/CHECK VALVE AND FITTINGS ARE PROVIDED SEPARATELY, TO BE ASSEMBLED BY OTHERS
2. TO ASSEMBLE, APPLY A DOUBLE LAYER OF TEFLON TAPE, AND A LAYER OF PIPE DOPE (SUPPLIED BY OTHERS) TO THE THREADS ON THE PLASTIC FITTINGS AND INSTALL PER THE MANUFACTURER'S INSTRUCTIONS
3. ASSEMBLY IS TO BE PRESSURE TESTED (BY OTHERS)
4. ASSEMBLY IS TO BE USED WITH SDR11 HDPE PIPE
5. TO ORDER SS LATERAL KIT, USE PART NUMBER NC0193G01
6. CURB BOX IS TO BE ORDERED SEPARATELY, SEE ABOVE

SGS	DN	11/02/11	A	3/16
DR BY	CHK'D	DATE	ISSUE	SCALE
				
STAINLESS STEEL LATERAL KIT 1-1/4" SDR 11 HDPE PIPE				
NA0330P02				



Environment One Corp. - 2773 Balltown Road - Niskayuna, NY 12309
 Phone: (518) 346-6161 Fax: (518) 346-4382

QUOTATION

Number: 1/23/22
 Revision : -
 Revision Date: N/A

Thank you for your interest in Environment One, its products and services.
 We are pleased to offer this quotation for your consideration.

To: City of Port St. Lucie - Utility Systems Department 900 SE Ogden Ln Port St. Lucie FL, 34983	ORIGINAL DATE	23-Jan-22
	REFERENCE	PSL Commercial Stations
Attn: Laney Southerly, PE Engineering Manager, Port St. Lucie Utilities 772-873-6442		
Project: PSL-USD/Port St. Lucie FL, 34983		

Item No.	Items	Unit	Quantity	Unit Price	Total Price
1	WH472- 92 (W001S47D14T) WT47 - 92 in. Total Station Height 48.9 in. Discharge Cover 1, 6 in. DWV (SCH40) Field Installed Grommet	EA	1	\$ 3,104.00	\$ 3,104.00
2	W-Series Grinder Pumps (W200P10AAF) 240 Volt Model 7" Core Cable 72 in. Flexi Hose	EA	2	\$ 2,508.00	\$ 5,016.00
3	Duplex Panel with GEN-AUTO (PC0919G62) T260 240V Gen-Rec W/ Auto Transfer, Hour Meters & GFCI	EA	1	\$ 1,792.00	\$ 1,792.00
4	NC0193G01 - Curb Stop Kit, Stainless Steel, 1-1/4" Compression Fittings for SDR 11	EA	1	\$ 158.00	\$ 158.00
				TOTAL	\$ 10,070.00

ITEMS INCLUDED IN ABOVE PRICING:

- All pumps include 32' cables & discharge components
- Submittals
- Delivery to Jobsite in Truckload Quantities per FREIGHT Item below
- Warranty - Per E/One's standard Limited Warranty for a period as described above from start up date

ITEMS NOT INCLUDED:

- Installation, field piping, field wiring, concrete ballast, taxes of any kind or type, nor any item not specifically included in this proposal

E/ONE STANDARD TERMS FOR PSL ARE ATTACHED:

- Net 30 days from the date of invoice at time of shipment. Environment One's standard Terms and Conditions are attached and are considered to be part of this quotation proposal

FREIGHT:

- FOB Destination, Freight Prepaid and Add.
- FOB Destination, Freight Prepaid and Allow if order can be consolidated into an existing PSL FTL

DELIVERY:

- FOUR Weeks ARO

VALIDATION:

- This proposal is valid for 30 days from date above

U.S. export control laws apply to the products and technologies covered by this quotation. Export or re-export of these products or technologies may require the prior approval of the U.S. government in accordance with the Export Administration Regulations, and OFAC rules, and customer agrees to notify Environment One Corporation, Inc. of any such intended export or re-export. Diversion contrary to U.S. law is prohibited.

On Behalf of Environment One Corp.



Chris Nedwick
 cnedwick@eone.com
 (518) 596-2186

WH472/WR472

General Features

The model WH472 or WR472 grinder pump station is a complete unit that includes: two grinder pumps, check valve, polyethylene tank, controls, and alarm panel. Designed specifically for higher-flow applications where local codes dictate higher storage requirements. The lower portion of the tank has a smaller diameter, tapered down to a dish-shaped bottom. The tank access opening is ideally sized for smaller diameter, low-profile covers for minimal “footprint.”

- Rated for flows of 3500 gpd (13,249 lpd)
- 476 gallons (1802 liters) of capacity
- Standard outdoor heights range from 77 inches to 122 inches

The WH472 is the “hardwired,” or “wired,” model where a cable connects the motor controls to the level controls through watertight penetrations.

The WR472 is the “radio frequency identification” (RFID), or “wireless,” model that uses wireless technology to communicate between the level controls and the motor controls.

Operational Information

Motor

1 hp, 1,725 rpm, high torque, capacitor start, thermally protected, 120/240V, 60 Hz, 1 phase

Inlet Connections

4-inch inlet grommet standard for DWV pipe. Other inlet configurations available from the factory.

Discharge Connections

Pump discharge terminates in 1.25-inch NPT female thread. Can easily be adapted to 1.25-inch PVC pipe or any other material required by local codes.

Discharge

15 gpm at 0 psig (0.95 lps at 0 m)
11 gpm at 40 psig (0.69 lps at 28 m)
7.8 gpm at 80 psig (0.49 lps at 56 m)

Accessories

E/One recommends that the Uni-Lateral, E/One’s own stainless steel check valve, be installed between the grinder pump station and the street main for added protection against backflow.

Alarm panels are available with a variety of options, from basic monitoring to advanced notice of service requirements.

The Remote Sentry is ideal for installations where the alarm panel may be hidden from view.

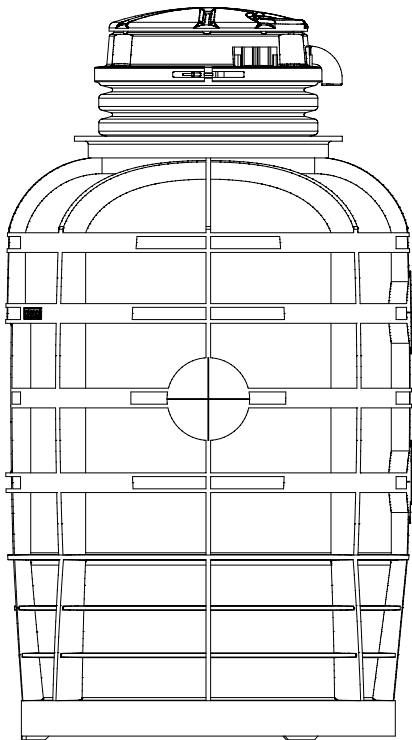

Patent Numbers: 5,752,315
5,562,254 5,439,180

NA0223P01 Rev C

OPTIONS : WH472 (HARD WIRED LEVEL CONTROLS) WR472 (WIRELESS LEVEL CONTROLS)

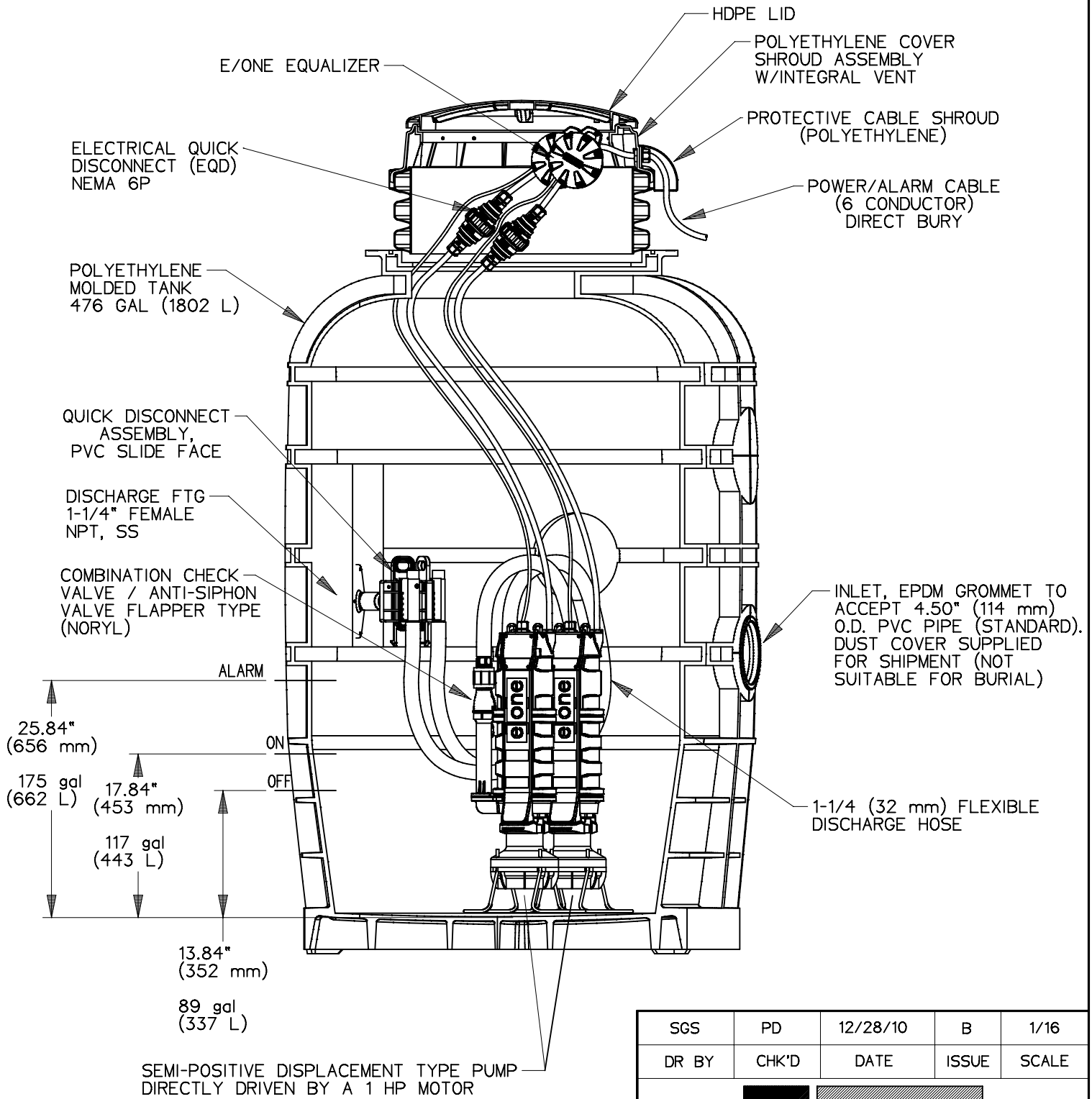

CONCRETE BALLAST MAY BE REQUIRED
 SEE INSTALLATION INSTRUCTIONS
 FOR DETAILS

NOTE: DIMENSIONS ARE FOR REFERENCE ONLY

SGS	PD	12/28/10	B	1/16
DR BY	CHK'D	DATE	ISSUE	SCALE



MODEL WH472 / WR472
 DETAIL SHEET

NA0223P02

OPTIONS : **WH472-92**

(HARD WIRED
LEVEL CONTROLS)

WR472-92

(WIRELESS
LEVEL CONTROLS)

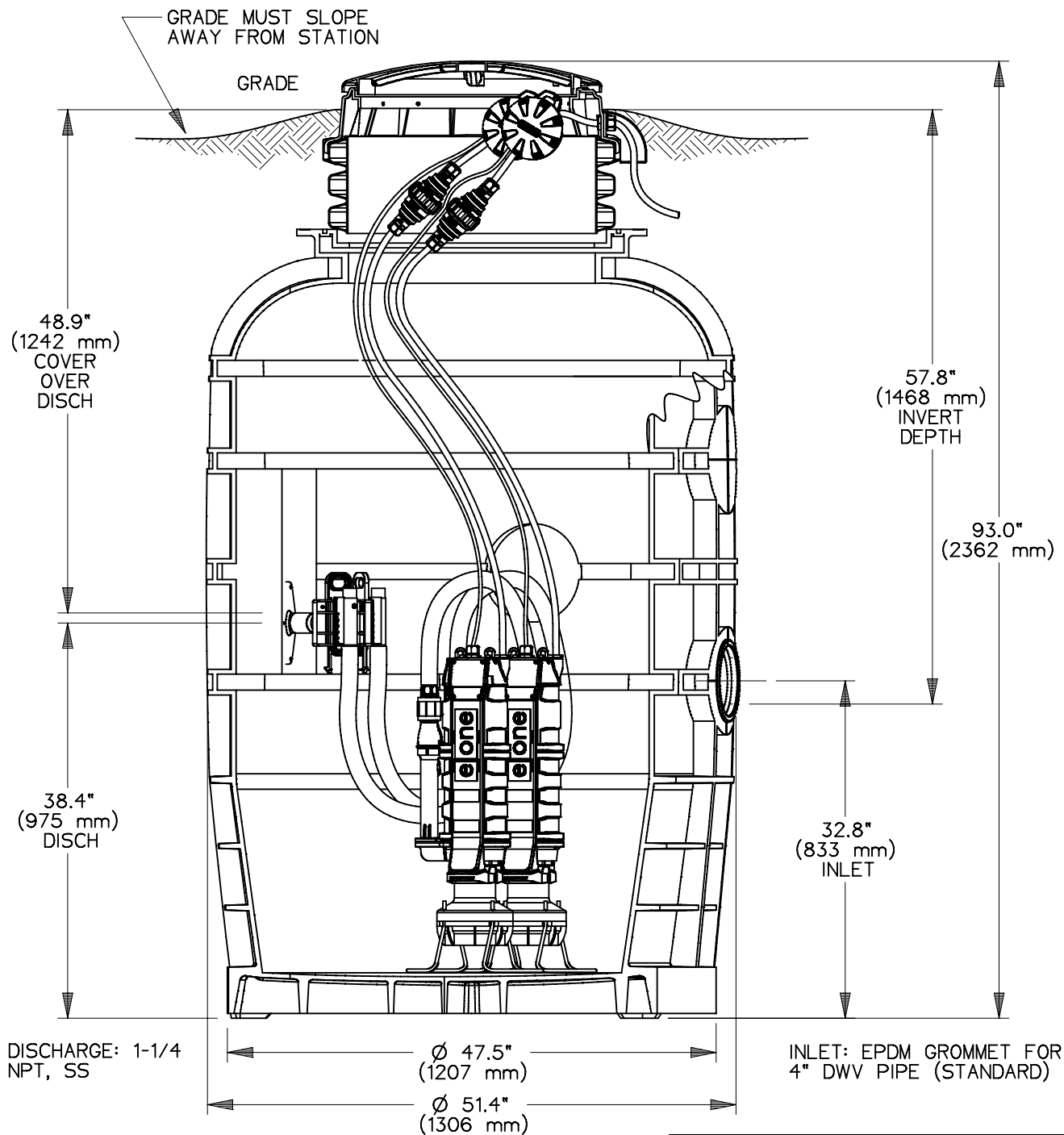

CONCRETE BALLAST MAY BE REQUIRED
SEE INSTALLATION INSTRUCTIONS
FOR DETAILS

NOTE: DIMENSIONS ARE FOR REFERENCE ONLY

SGS	PD	12/28/10	A	1/16
DR BY	CHK'D	DATE	ISSUE	SCALE



MODEL WH472-92 / WR472-92

NA0223P04

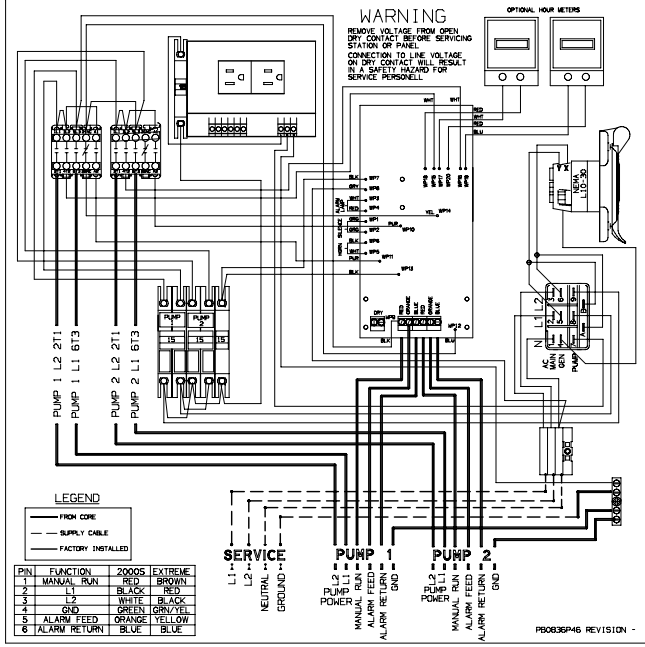
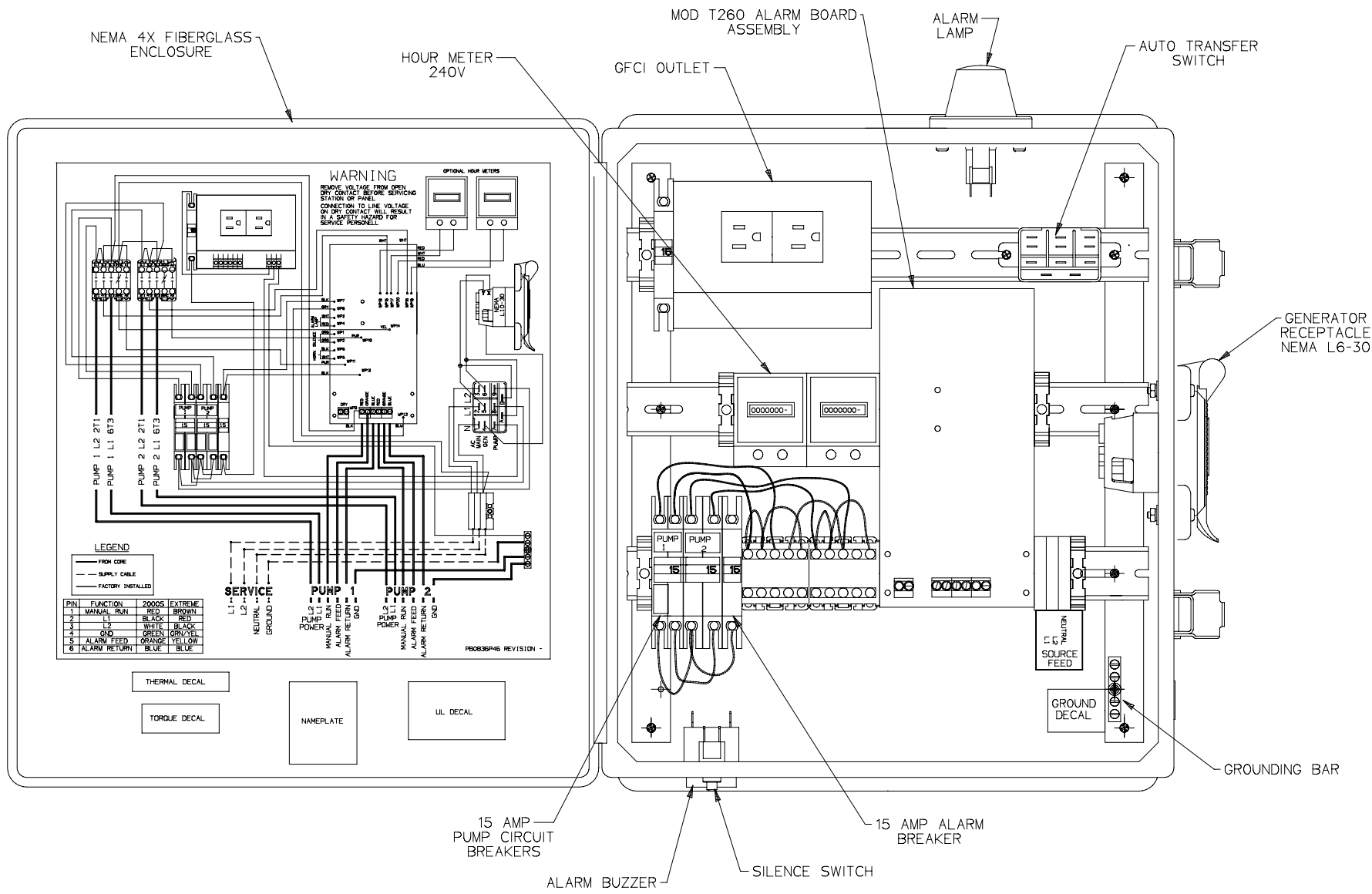

THERMAL DECAL
 TORQUE DECAL
 NAMEPLATE
 UL DECAL

Model T260 DUPLEX ALTERNATING PANEL
 PART NUMBER PC0919G62

PIN	FUNCTION	2000S	EXTREME
1	MANUAL RUN	RED	BROWN
2	L1	BLACK	RED
3	L2	WHITE	BLACK
4	GND	GREEN	GRN/YEL
5	ALARM FEED	ORANGE	YELLOW
6	ALARM RETURN	BLUE	BLUE

UNLESS OTHERWISE SPECIFIED THE FOLLOWING APPLIES	OR BY: SGS	environment CORPORATION
SHOP PRACTICE PER E-5000-01	CHK'D:	
GEOMETRIC TOLERANCES PER ASA STD Y14.5	ENG	
✓ MACHINE FINISH	SCALE	MOD T260 DUPLEX PANEL, 240V GEN RECP, AUTOXFER, GFCI, HM
TOLERANCE ON DIMENSIONS	WT	FIRST MADE FOR -
2 PLACES 3 PLACES ANGLES	APPD	ESD 09-0044
±0.02 ±0.005 ±30'	ISSUED	1
USED ON DWGS	CODE IDENT	DRAWING NUMBER SH 1 OF 1 REV