

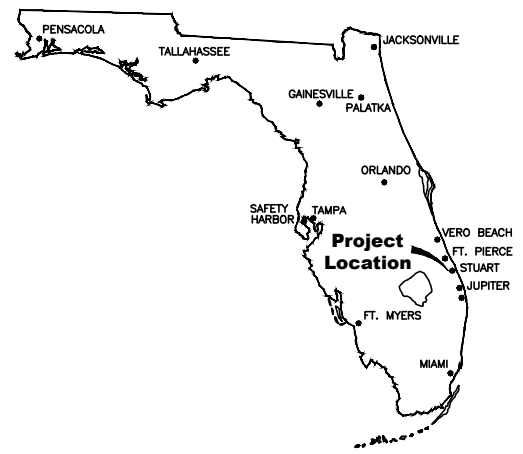

CONSTRUCTION PLANS OF TOM MACKIE BLVD. EXTENSION

FOR
THE CITY OF PORT ST. LUCIE
LYING IN SECTION 22, TOWNSHIP 37 SOUTH,
RANGE 39 EAST
ST. LUCIE COUNTY, FLORIDA
STATE FUNDED GRANT AGREEMENT (SFGA)
FINANCIAL PROJECT ID 453184-1-54-01



Location Map

NOTE: THESE PLANS ARE IN ENGLISH UNITS.

THESE PLANS HAVE BEEN PREPARED IN ACCORDANCE WITH THE STATE OF FLORIDA, DEPARTMENT OF TRANSPORTATION.

STANDARD PLANS, FY 2023-24

STANDARD SPECIFICATIONS FOR ROAD AND BRIDGE CONSTRUCTION, FY 2023-24

THE MANUAL OF UNIFORM MINIMUM STANDARDS FOR DESIGN, CONSTRUCTION AND MAINTENANCE FOR STREETS AND HIGHWAYS (GREENBOOK), 2018 EDITION

THE FEDERAL HIGHWAY ADMINISTRATION (FHWA) MANUAL ON UNIFORM TRAFFIC CONTROL DEVICES, 11TH EDITION

THE CITY OF PORT ST. LUCIE PUBLIC WORKS DEPARTMENT ENGINEERING STANDARDS FOR LAND DEVELOPMENT (MOST CURRENT EDITION), AS AMENDED BY CONTRACT DOCUMENTS.

SHEET INDEX

- 1 - KEY SHEET
- 2 - PROJECT LAYOUT
- 3 - TYPICAL SECTION
- 4 - GENERAL NOTES
- 5 - EROSION AND SEDIMENT CONTROL
- 6 - EROSION CONTROL NOTES
- 7 - EROSION CONTROL DETAILS
- 8 - DRAINAGE MAP
- 9-15 PLAN AND PROFILE
- 16-19 CROSS SECTIONS
- 20 - PAVING AND DRAINAGE DETAILS
- 21-23 PAVEMENT MARKING AND SIGNAGE
- 24 - OVERALL UTILITY
- 25-31 UTILITY PLAN
- 32-33 PSLUSD GENERAL NOTES
- 34 - UTILITY DETAILS

ENGINEER

MR. JOSEPH W. CAPRA, P.E.
CAPTEC ENGINEERING, INC.
301 NW FLAGLER AVENUE
P.E. NO. 37638
STUART, FLORIDA 34994
PHONE: (772) 692-4344
FAX: (772) 692-4341

OWNER

CITY OF PORT ST. LUCIE
PUBLIC WORKS DEPARTMENT
121 SW PORT ST. LUCIE BLVD.
PORT ST. LUCIE, FLORIDA 34984
FRANK KNOTT
(PROJECT MANAGER)
PHONE: (772) 344-4290
FAX: (772)-871-5289

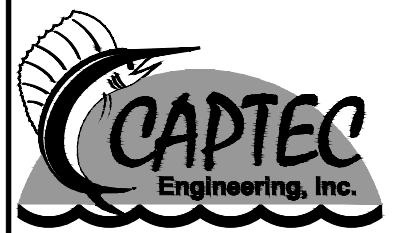

Civil Engineering Professionals

Engineering Business
No. EB-0007657

301 N.W. Flagler Avenue
Stuart, Florida 34994
Phone: (772) 692-4344
Fax: (772) 692-4341

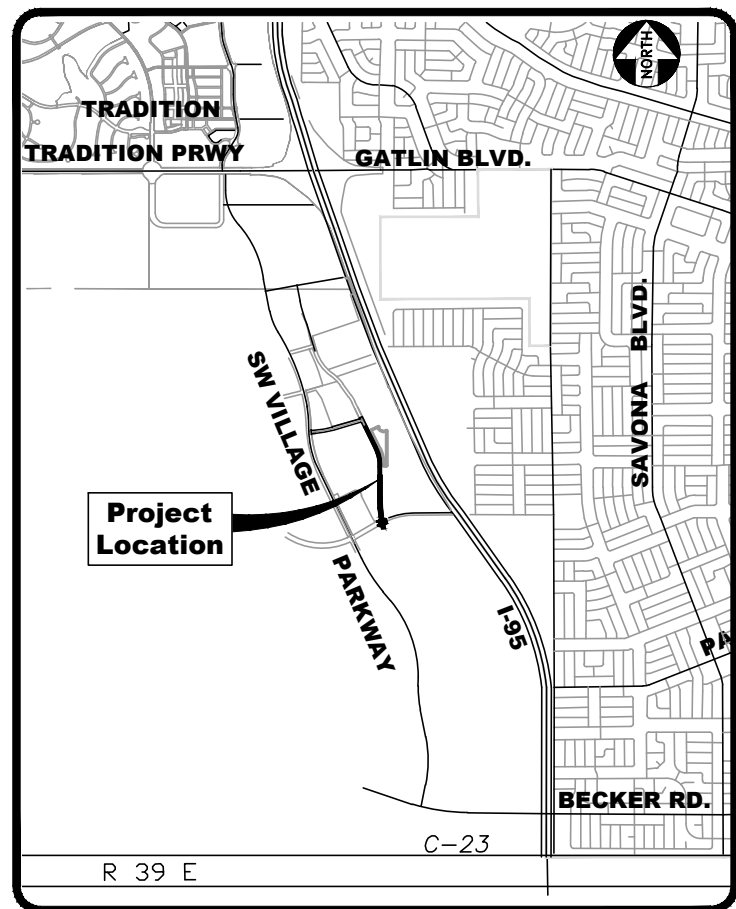

VICINITY MAP

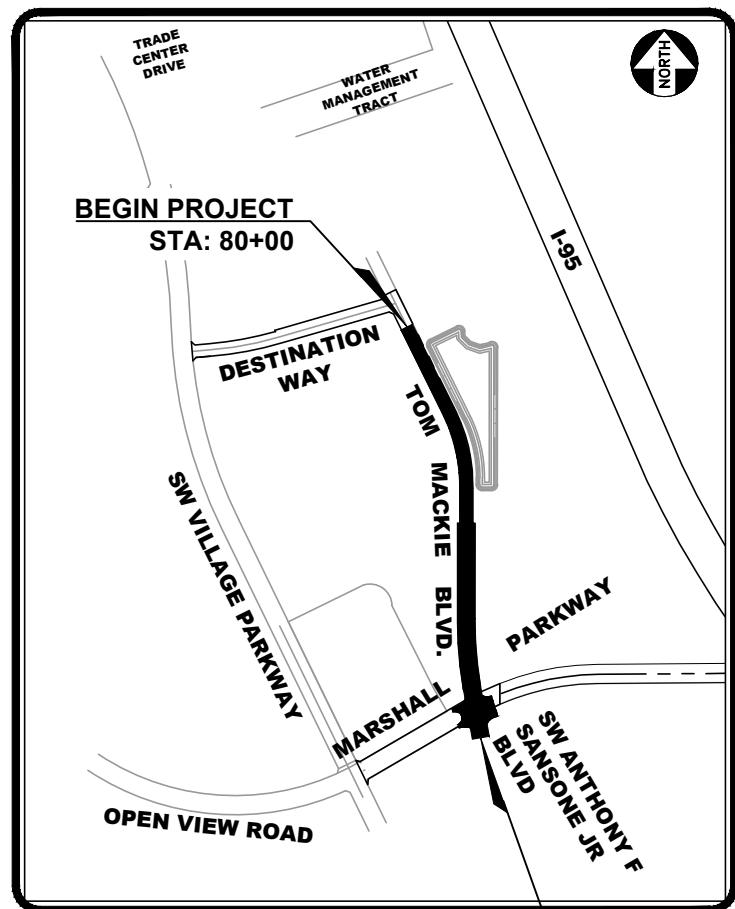

LOCATION MAP

END PROJECT
STA: 113+07.26

BID SET
05-14-24
(REV. 05-31-24)

PSL # P24-010 PSLUSD # 11-900-23

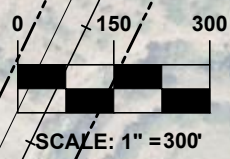
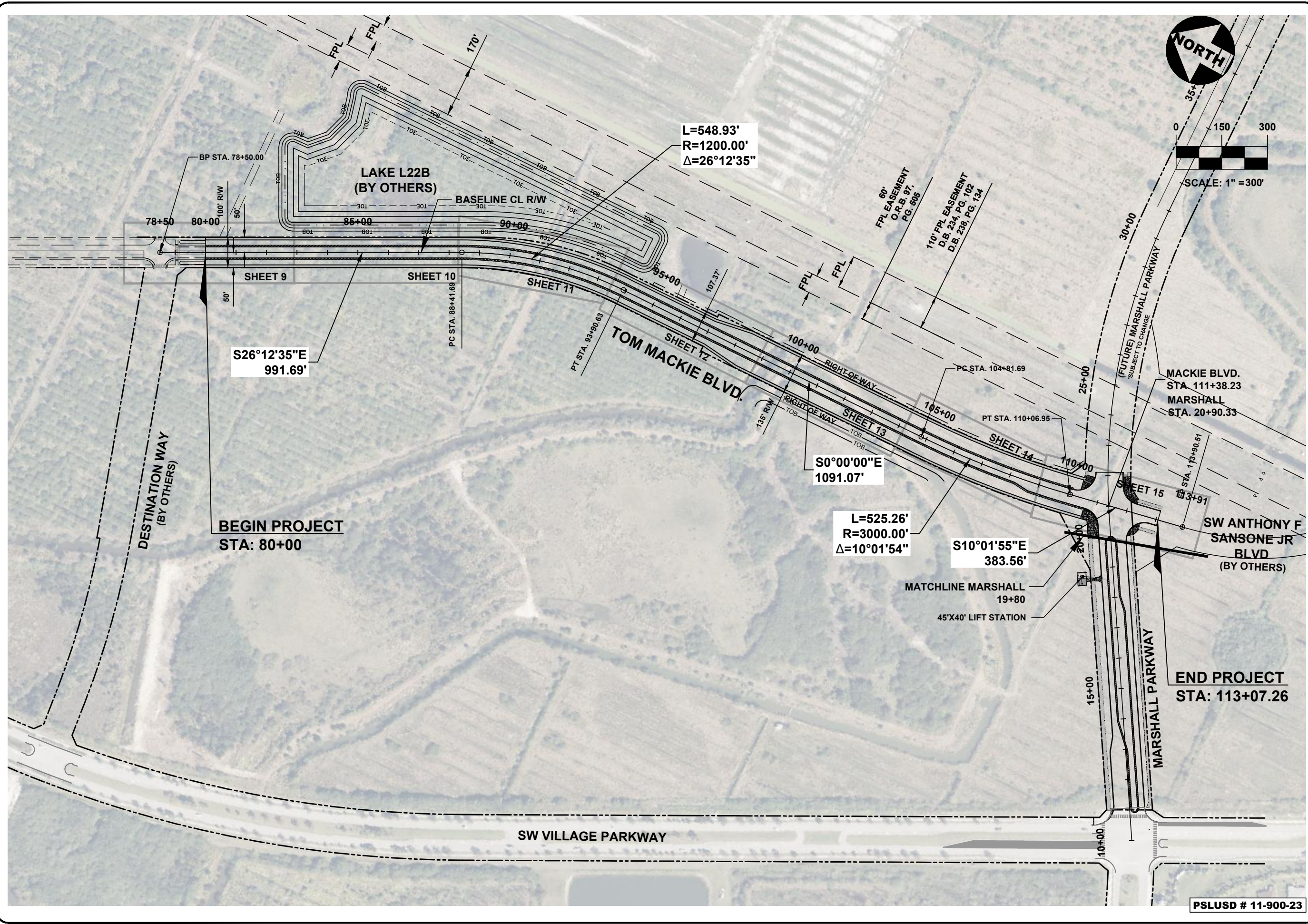

301 N.W. Flagler Ave.
 Stuart, Florida 34994
 Phone: (772) 892-4344
 Fax: (772) 892-4341

Engineering Business
 No. EB-007857
 Civil Engineering Professionals

DATE: 8-24-22

DRAWN BY:	MDB
DESIGNED BY:	MDB
CHECKED BY:	JWC
PROJECT NO.:	2032
HORIZ. SCALE:	1" = 300'
VERT. SCALE:	1" = 300'

CADD FILE:

NO.	DATE	BY	REVISIONS
1	05-14-24	MDB	BID SET

SCALE VERIFICATION

0 0.5 1 1.5

SOLID BAR IS EQUAL TO HALF AN INCH ON DIMENSIONS
 TO ADJUST ALL SCALED DIMENSIONS ACCORDINGLY

TOM MACKIE BLVD. EXTENSION
 CITY OF PORT ST. LUCIE, FLORIDA

PROJECT LAYOUT

Joseph W. Capra
 301 N.W. Flagler Ave.
 Stuart, Florida 34994
 P.E. No. 37638

Printed Date:

JOB No.: 2032
 SHEET 2 OF 34

PSLUSD # 11-900-23

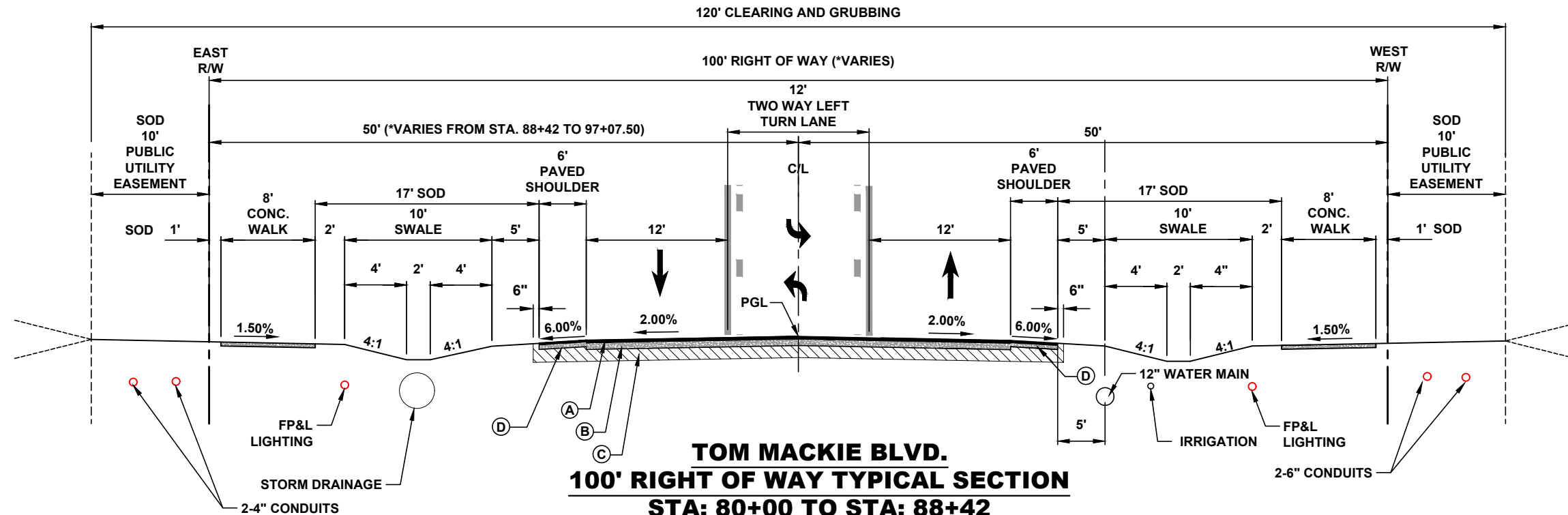

TOM MACKIE BLVD.
100' RIGHT OF WAY TYPICAL SECTION
STA: 80+00 TO STA: 88+42
DESIGN SPEED 35 MPH
POSTED SPEED 30 MPH

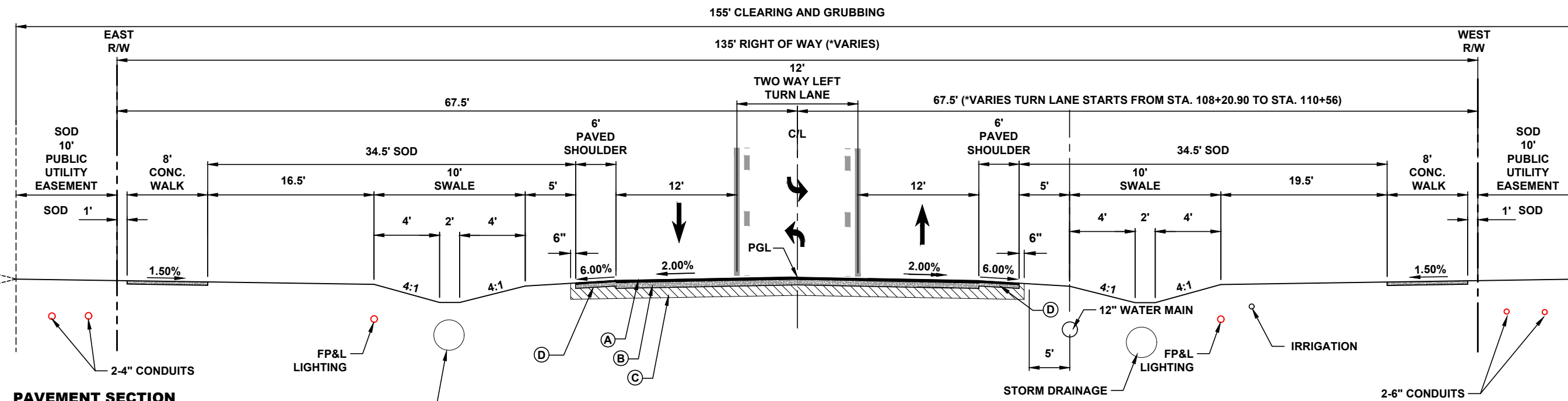

TOM MACKIE BLVD.
135' RIGHT OF WAY TYPICAL SECTION
STA: 97+07.50 TO STA: 108+20.90
DESIGN SPEED 35 MPH
POSTED SPEED 30 MPH

- PAVEMENT SECTION**
- (A) FIRST LIFT: SP (TRAFFIC C) (1 1/2")
FINAL LIFT: SP-12.5 (TRAFFIC C) SP-12.5 (1 1/2")
 - (B) 10" OPTIONAL BASE GROUP 9 COMPACTED TO 98% AASHTO T-180
 - (C) 12" SUBGRADE COMPACTED TO 98% AASHTO T-180
STABILIZED TO 75 P.S.I. FBV OR LBR40 TO ULTIMATE DEPTH.
 - (D) PAVED SHOULDER
(TRAFFIC C) SP-12.5 (1 1/2")
OPTIONAL BASE GROUP 1- 4"

TRAFFIC DATA

OPENING YEAR (2025)	AADT = 5,925
DESIGN YEAR (2045)	AADT = 7,900
PERCENTAGE TRUCKS	15

P:\2000\2032 - PSL Hegener Drive Phase 3\DWG\2032 TYPICAL SECTION.dwg, 5/17/2024 11:30:57 AM

301 NW Flagler Ave.
 Stuart, Florida 34994
 Phone: (772) 892-4344
 Fax: (772) 892-4341

Engineering Business
 No. EB-007857
 Civil Engineering Professionals

DATE: 8-24-22

DRAWN BY:	MDB
DESIGNED BY:	MDB
CHECKED BY:	JWC
PROJECT NO.:	2032
HORIZ. SCALE:	N.T.S.
VERT. SCALE:	
CADD FILE:	

NO.	DATE	BY	REVISIONS
1	05-14-24	MDB	BID SET

SCALE VERIFICATION

0 0.5 1 1.5 2 2.5 3 3.5 4 4.5 5

SOLID BAR IS EQUAL TO HALF AN INCH ON ADJUST ALL SCALED DIMENSIONS ACCORDINGLY

TOM MACKIE BLVD. EXTENSION
 CITY OF PORT ST. LUCIE, FLORIDA

TYPICAL SECTION

Joseph W. Capra
 301 N.W. Flagler Ave.
 Stuart, Florida 34994
 P.E. No. 37638

Printed Date:

PSLUSD # 11-900-23

JOB No.: 2032
 SHEET 3 OF 34

PSL # P24-010

GENERAL NOTES

1. BENCHMARK ELEVATIONS SHOWN ON THE PLANS ARE NORTH AMERICAN VERTICAL DATUM OF 1988 (NAVD 1988).
2. ALL DRAINAGE INFRASTRUCTURE IS TO REMAIN UNLESS OTHERWISE NOTED.
3. ALL GRADES SHOWN ARE FINISHED GRADES, UNLESS OTHERWISE NOTED.
4. STATIONING AND OFFSETS REFER TO THE BASELINE OF CONSTRUCTION, UNLESS OTHERWISE NOTED.
5. EXISTING UTILITIES ARE TO REMAIN IN PLACE UNLESS OTHERWISE NOTED.
6. ANY PUBLIC LAND CORNER WITHIN THE LIMITS OF CONSTRUCTION IS TO BE PROTECTED. IF A CORNER MONUMENT IS IN DANGER OF BEING DESTROYED AND HAS NOT BEEN PROPERLY REFERENCED, THE ENGINEER SHOULD NOTIFY THE CITY SURVEYOR, WITHOUT DELAY, BY TELEPHONE (772) 871-5178.
7. EXISTING IMPACTED DRIVEWAYS WITHIN THE LIMITS OF THIS PROJECT ARE TO BE RESTORED TO THE CITY OF PORT ST. LUCIE (CITY OF PSL) STANDARDS AT THE SAME LOCATION AND WIDTH, UNLESS OTHERWISE SHOWN IN THE PLANS. RESIDENTIAL ACCESS MUST BE MAINTAINED AT ALL TIMES. LIMITS OF DRIVEWAY REMOVAL ARE TO BE DETERMINED BY THE PROJECT MANAGER AT THE TIME OF CONSTRUCTION. IN WHICH CASE, CONTRACTOR WILL NOTIFY HOMEOWNER 48 HOURS IN ADVANCE AND WILL COMPLETE DRIVEWAY RECONSTRUCTION WITHIN ONE WEEK OF THIS NOTIFICATION.
8. NO CONSTRUCTION SHALL COMMENCE UNTIL ALL REQUIRED PERMITS AND APPROVALS HAVE BEEN SECURED AND THE CONTRACTOR IS ISSUED A "NOTICE TO PROCEED".
9. DURING CONSTRUCTION, SHOULD ANY DRAINAGE STRUCTURES (INCLUDING PIPES) BE FOUND THAT ARE NOT SHOWN ON THE PLANS, NOTIFY THE ENGINEER IMMEDIATELY.
10. IN REFERENCE TO EXISTING UTILITIES AND UTILITY ADJUSTMENTS:

A. THE LOCATION OF UTILITIES SHOWN ON THE PLANS ARE APPROXIMATE ONLY. THE EXACT HORIZONTAL AND VERTICAL LOCATIONS SHALL BE DETERMINED BY THE CONTRACTOR PRIOR TO CONSTRUCTION. IN ADDITION, THE CONTRACTOR SHALL BE RESPONSIBLE TO VERIFY IF "OTHER" UTILITIES (NOT SHOWN ON THE PLANS) EXIST WITHIN THE AREA OF CONSTRUCTION. SHOULD THERE BE UTILITY CONFLICTS, THE CONTRACTOR SHALL INFORM THE ENGINEER AND NOTIFY THE RESPECTIVE UTILITY OWNER(S) TO RESOLVE UTILITY CONFLICTS AND UTILITY ADJUSTMENTS AS REQUIRED.

B. WATER AND SANITARY SEWER UTILITY WORK SHALL BE IN CONFORMANCE WITH ALL WATER AND SANITARY SEWER UTILITY WORK SHALL BE IN CONFORMANCE WITH ALL CODES, STANDARDS, AND ORDINANCES CURRENTLY ADOPTED BY THE STATE OF FLORIDA D.E.P. AND PORT ST. LUCIE UTILITY SYSTEMS DEPARTMENT (PSLUSD).

11. THE CONTRACTOR SHALL NOTIFY UTILITY OWNERS THROUGH SUNSHINE STATE ONE CALL OF FLORIDA (1-800-432-4770) AND UTILITY OWNERS LISTED BELOW IN TWO BUSINESS DAYS (OR 10 DAYS IF ON THE JOB SITE).

COMPANY	CONTACT	TEL. NO.
AT&T	MARK LINSOTT	(321) 388-9376
COMCAST CABLE	ANTHONY SPRINGSTEEL	(561) 804-0973
FLORIDA CITY GAS	RON MULLER	(772) 337-7011
FLORIDA POWER & LIGHT. CO.	ROB MORRIS	(772) 223-4215
PSL CRA PROJECT MANAGER	FRANK KNOTT	(772) 380-6022
PSL UTILITY SYSTEMS DEPT.	LANEY SOUTHERLY, PE	(772) 873-6442

12. IF DEWATERING PERMIT IS REQUIRED FOR THIS PROJECT, THE CONTRACTOR WILL BE REQUIRED TO OBTAIN A DEWATERING PERMIT OR WATER USE PERMIT AND ALLOW TIME FOR THE SOUTH FLORIDA WATER MANAGEMENT DISTRICT AND/OR FDEP TO REVIEW AND APPROVE THE PERMIT PRIOR TO THE CONSTRUCTION START DATE.

13. WORK HOURS ARE FROM 7:00 AM TO DUSK, MONDAY-FRIDAY. WORK WILL NOT BE ALLOWED ON WEEKENDS OR HOLIDAYS OBSERVED BY THE CITY OF PORT ST. LUCIE UNLESS WRITTEN APPROVAL IS OBTAINED FROM THE CITY. THE CONTRACTOR MUST RECEIVE WRITTEN PERMISSION FROM THE CITY AND PROVIDE AN APPROVED MOT PLAN BEFORE ANY LANE CLOSURES OCCUR.

14. THE CONTRACTOR SHALL COORDINATE SELECTION AND REVIEW OF ANY PROPOSED STAGING AREAS ASSOCIATED WITH THIS PROJECT WITH FRANK KNOTT, PM.

15. EXISTING LANDSCAPE IMPROVEMENT THAT ARE IN CONFLICT WITH THE PROPOSED IMPROVEMENTS ARE TO BE RELOCATED PER THE DIRECTION OF THE PROJECT MANAGER. VACANT LOTS WITH VEGETATION SUCH AS INVASIVE PLANTS AND EXOTICS SHALL BE CLEARED IN THE LOCATION IN CONFLICT WITH THE PROPOSED SIDEWALK AND SWALE-LINER INSTALLATION.

16. LANE CLOSURES SHALL BE COORDINATED WITH ST. LUCIE COUNTY SCHOOL BOARD, ST.LUCIE COUNTY FIRE RESCUE AND THE CITY OF PORT ST. LUCIE AT LEAST 48 HOURS IN ADVANCE.

17. FINAL ADJUSTMENT OF ANY STORM STRUCTURE TOPS SHALL BE THE RESPONSIBILITY OF THE CONTRACTOR. DRAINAGE STRUCTURES SHALL BE PROVIDED IN 2 PARTS.

In addition, the following permits have been obtained for the improvements depicted in these plans:

Permit	File No.	Expiration
SFWMD ERP (Tom Mackie/Marshall)	230630-39273	February 15, 2029
SFWMD ERP (E/W 2)	230630-39275	January 10, 2029
SG CDD (Tom Mackie/Marshall)	WA19-144-207	
SG CDD (E/W 2)	WA19-144-208	
FDOT SFGA	453184-1	ERC Response submitted: 4/2/24

18. ANY KNOWN OR SUSPECT HAZARDOUS MATERIAL FOUND ON THE PROJECT BY THE CONTRACTOR SHALL BE IMMEDIATELY REPORTED TO THE PROJECT MANAGER, WHO SHALL DIRECT THE CONTRACTOR TO PROTECT THE AREA OF KNOWN OR SUSPECT HAZARDOUS MATERIAL FROM FURTHER ACCESS. THE PROJECT ENGINEER IS TO NOTIFY THE PROPER REGULATORY AUTHORITY OF THE DISCOVERY. THE PROPER REGULATORY AUTHORITY WILL ADVISE/DIRECT THE PROJECT ENGINEER IN THE INVESTIGATION, IDENTIFICATION AND/OR REMOVAL/REMEDIATION OF THE MATERIAL IN QUESTION AS NEEDED. THE CONTRACTOR SHALL NOT RETURN TO THE AREA OF SUSPECTED CONTAMINATION UNTIL APPROVAL IS PROVIDED BY THE PROJECT MANAGER.

19. THE CONTRACTOR SHALL NOT BRING ANY HAZARDOUS MATERIALS ONTO THE PROJECT. SHOULD THE CONTRACTOR REQUIRE SUCH FOR PERFORMING THE CONTRACTED WORK, THE CONTRACTOR SHALL REQUEST, IN WRITING, WRITTEN PERMISSION FROM THE PROJECT MANAGER IN ACCORDANCE WITH THE MATERIAL SAFETY DATA SHEET (MSDS) FOR EACH HAZARDOUS MATERIAL PROPOSED FOR USE.

20. EXISTING MAILBOXES SHALL BE MAINTAINED AT ALL TIMES. CONTRACTOR IS RESPONSIBLE FOR REPLACING DAMAGED MAILBOXES WITH LIKE KIND AT NO ADDITIONAL COST.

21. ALL WORK ASSOCIATED WITH THIS PROJECT IS TO BE PERFORMED WITHIN THE RIGHT-OF-WAY LIMITS AS DEPICTED ON THE PLAN SHEETS.

22. ALL CONCRETE SIDEWALK JOINTS SHALL BE TOOLED WITHOUT EXPANSION JOINTS.

23. ALL WORK, CONCRETE AND MATERIALS SHALL COMPLY WITH THE LATEST EDITION, INCLUDING ALL REVISIONS, OF THE FOLLOWING STANDARDS AND PUBLICATIONS: -AMERICAN ASSOCIATION OF STATE HIGHWAY AND TRANSPORTATION OFFICIALS (AASHTO) -AMERICAN CONCRETE INSTITUTE (ACI) -AMERICAN SOCIETY FOR TESTING MATERIAL (ASTM) -AMERICANS WITH DISABILITIES ACT ACCESSIBILITY GUIDELINES (ADAAG) -FDOT ROADWAY AND TRAFFIC DESIGN STANDARDS -FDOT STANDARD SPECIFICATIONS FOR ROAD AND BRIDGE CONSTRUCTION -FDOT STRUCTURES STANDARD INDEX.

24. ALL DISTURBED AREAS SHALL BE REPAIRED TO EXISTING CONDITIONS OR BETTER. THE CONTRACTOR SHALL ONLY BE ENTITLED FOR PAYMENT OF AUTHORIZED AREAS WITHIN THE PROJECT WORK LIMITS. THE PROJECT WORK LIMITS SHALL BE ESTABLISHED BY THE CITY OF PORT ST. LUCIE PRIOR TO CONSTRUCTION. THE CONTRACTOR SHALL MAKE EVERY EFFORT TO MINIMIZE UNNECESSARY DAMAGE. ALL DAMAGED AREAS OUTSIDE THE PROJECT WORK LIMITS MUST BE REPAIRED TO EXISTING CONDITIONS (INCLUDING IRRIGATION LINES AND EQUIPMENT) OR BETTER, THE COST OF THE CONTRACTOR, PRIOR TO FINAL PAYMENT.

25. ALL SOD SHALL HAVE A WARRANTY OF 45 DAYS AFTER THE FINAL COMPLETION DATE OF THE PROJECT. SOD REPLACED BY THE CONTRACTOR MUST BE THE SAME TYPE AS REMOVED.

26. ROADSIDE GRADING NOTES:

- a. SIDEWALK LAYOUT SHALL BE TYPICALLY A 6' OFFSET FROM THE EDGE OF THE TRAVEL WAY ALONG ONE SIDE OF THE ROAD.
- b. SIDEWALKS ARE TO BE 4 IN. THICK CONCRETE TYPICALLY.
- c. SIDEWALKS WITHIN 6' OF INTERSECTIONS SHALL BE 6 IN. THICK.
- d. SIDEWALK CROSS-SLOPE SHALL NOT EXCEED 2% IN ANY LOCATION.
- e. SIDEWALK LONGITUDINAL SLOPE SHALL NOT EXCEED 5% AT ANY LOCATION.
- f. GRADING BASE LINE IS CONSIDERED EDGE OF PAVEMENT.
- g. SOD SHALL BE SET 0.5 IN. BELOW IN GRADE BELOW THE EDGE OF PAVEMENT. SWALE FORESLOPE AND BACKSLOPE SHALL BE 3:1 MAX, 4:1 TYP. (MINIMAL GRADING PREFERRED).
- h. SWALE GRADING (GUTTER-LINE) IS 0.15% MIN. 0.20% PREFERRED.
- i. 12" SUBGRADE SHALL BE COMPACTED TO 98% OF MODIFIED PROCTOR (ASTM D1557/AASHTO T-180).
- j. ALL AREAS ADJACENT TO THE PROPOSED SIDEWALK SHALL BE RE-GRADED TO REPAIR ANY EROSION, POTENTIAL DROP OFFS, OR TRIPPING HAZARDS.

27. DRIVEWAY NOTES:

- a. DRIVEWAY WIDTHS VARY TYPICALLY FROM 10' (SINGLE-CAR) TO 20' WIDE (DOUBLE-CAR). PROPOSED SHALL MATCH EXISTING.
- b. DRIVEWAY REPLACEMENT SHALL BE 6" CONCRETE UP TO 1' FROM THE RIGHT-OF-WAY LINE WHERE IT SHALL MATCH GRADE FLUSH WITH THE EXISTING DRIVEWAY. WORK OUTSIDE THE RIGHT-OF-WAY IS NOT INCLUDED WITH THIS PROJECT.
- c. DRIVEWAY CULVERTS ARE TYPICALLY 4' EXTENDED PIPE OR CONCRETE END TREATMENTS CENTERED ON BOTH SIDES. END TREATMENTS WHETHER EXTENDED PIPE OR CONCRETE END TREATMENTS SHALL BE REMOVED AND REPLACE TO MATCH EXISTING.
- d. DRIVEWAY CULVERTS SHALL BE SET ON FIRM AND UNYIELDING GROUND AND SET TO MATCH DRAINAGE CONVEYANCE FLOW LINE OF UPSTREAM AND DOWNSTREAM CULVERT INVERTS.
- e. BACKFILL USED DURING THE INSTALLATION OF DRIVEWAY CULVERTS SHALL BE REPLACED IN 12" LIFTS. COMPACTED TO 98% OF MODIFIED PROCTOR (ASTM D1557/AASHTO T-180).
- f. AT THE TIME OF CONSTRUCTION, IF THE CONCRETE DRIVEWAY AND CULVERT PIPE ARE FOUND IN GOOD CONDITION AND NOT IN CONFLICT WITH THE PROPOSED SIDEWALK THEN THE CITY OFFICIAL CAN DETERMINE WHETHER IT TO REMAIN OR CONTINUE TO BE REPLACED.

28. CROSSWALK NOTES:

- a. ALL SIDE STREET INTERSECTIONS SHALL INCLUDE THERMOPLASTIC WHITE SPECIAL EMPHASIS MARKINGS PER FDOT STANDARD PLANS.
- b. ALL SIDEWALK AT SIDE STREET CROSSWALKS SHALL HAVE DETECTABLE WARNING SURFACES THAT EXTEND THE FULL WIDTH OF THE SIDEWALK AND IN THE DIRECTION OF TRAVEL 24 INCHES FROM EDGE OF PAVEMENT.

29. IF ANY OF THE NOTES ABOVE CONFLICT WITH THE PSL UTILITY STANDARDS MANUAL, THE MORE STRINGENT REQUIREMENT WILL APPLY.

30. THE PROPERTY OWNER, CONTRACTOR AND AUTHORIZED REPRESENTATIVES SHALL PROVIDE PICKUP, REMOVAL AND DISPOSAL OF LITTER WITHIN THE PROJECT LIMITS AND SHALL BE RESPONSIBLE FOR MAINTENANCE OF THE AREA FROM THE EDGE OF PAVEMENT TO THE PROPERTY LINE WITHIN THE CITY'S RIGHT-OF-WAY IN ACCORDANCE WITH CITY CODE, SECTION 41.08(G).

31. WITHIN THE LIMITS OF THIS PROJECT- TOM MACKIE BLVD. EXTENSION, MARSHALL PARKWAY AND DESTINATION WAY, THE PROJECT COMPLETED AN ENVIRONMENTAL ASSESSMENT BY EW CONSULTANTS INC. DATED DECEMBER 2023. THIS ASSESSMENT INCLUDED REVIEWED SOILS / LAND COVER TYPES/ TEMPORARILY ABOVE GROUND IMPOUNDMENT, WILDLIFE OBSERVATIONS, LIMITED SPECIES INVENTORY, AND NO WETLANDS WHERE FOUND ON THE SITE. THE REPORT REFERENCES PAST SFWMD AND ACOE PERMITS WITHIN THE PROJECT AREA.

DEMUCKING:

1. THE SUBJECT AREA PLUS AN AREA EXTENDING 5 FEET OUTSIDE PROPOSED CONSTRUCTION PERIMETERS SHOULD BE EXCAVATED AS NEEDED TO REMOVE ANY ENCOUNTERED DEEPER DEPOSITS OF ORGANIC SOIL. CARE MUST BE EXERCISED TO AVOID MIXING THE ORGANIC SOILS WITH THE UNDERLYING, SUITABLE GRANULAR MATERIALS. THE ORGANICS ARE TO BE DISPOSED OF AWAY FROM THE CONSTRUCTION AREA AS DIRECTED BY THE OWNER.
2. IN GENERAL IT IS DESIRED TO COMPLETE THE EXCAVATION AND BACKFILLING OPERATIONS IN AS SHORT A TIME AS POSSIBLE TO AVOID OPEN EXCAVATIONS. CONSIDERATION SHOULD BE GIVEN TO PROCEEDING WITH THE DEMUCKING/BACKFILLING OPERATION IN STAGES ACROSS THE DITCH SO THAT NO DEEP EXCAVATIONS REMAIN OPEN OVERNIGHT. SUCH GRADUAL APPROACH MAY ALSO REDUCE DEWATERING AND SLOPE BRACING NEEDS.
3. ONCE THE BOTTOM OF THE EXCAVATION IS INSPECTED AND APPROVED, BACKFILL CAN BE PLACED TO A HEIGHT OF 2 FEET ABOVE THE WATER TABLE. DEWATERING MEASURES APPEAR TO BE NECESSARY ON THIS SITE TO FACILITATE THE REMOVAL OF ANY ORGANIC SOILS, ALLOW THE INSPECTION OF ANY DEMUCKED AREAS, AND ALLOW THE COMPACTION OF THE BACKFILL. THE CONTRACTOR SHOULD CONSIDER DEMUCKING AND AT LEAST PARTIALLY BACKFILLING SMALL SEGMENTS OF THE SITE AT A TIME TO REDUCE DEWATERING NEEDS AND DISCHARGE FLOWS.

SEE GEOTECH RECOMMENDATIONS SHEET 6 OF 34

DENSIFICATION:

1. GRANULAR BACKFILL SHOULD BE PLACED IN THE DRY AND COMPACTED WITH A VIBRATORY ROLLER. ANY SOFT, YIELDING SOILS DETECTED DURING THIS OPERATION SHOULD BE EXCAVATED AND REPLACED WITH CLEAN, COMPACTED BACKFILL THAT CONFORMS WITH THE RECOMMENDATIONS BELOW. SUFFICIENT PASSES SHOULD BE MADE DURING THE COMPACTION OPERATIONS TO PRODUCE DRY DENSITIES NOT LESS THAN 98 PERCENT OF THE MODIFIED PROCTOR (ASTM D1557) MAXIMUM DRY DENSITY OF THE COMPACTED MATERIAL TO DEPTHS OF 1 FOOT BELOW THE COMPACTED SURFACE. IN ANY CASE, THE AREA SHOULD RECEIVE NOT LESS THAN 10 OVERLAPPING PASSES, HALF OF THEM IN EACH OF TWO PERPENDICULAR DIRECTIONS, IF POSSIBLE. THE INITIAL PASSES MAY HAVE TO BE GIVEN WITHOUT VIBRATIONS, AND THEN WITH THE LOWEST POSSIBLE VIBRATION SETTING SO AS TO ALLOW THE TRAFFIC OF THE VIBRATING ROLLER. AN ADDITIONAL SIX INCH LIFT MAY BE ADDED TO THE INITIAL LIFT IF THE TRAFFIC OF THE ROLLER IS MADE DIFFICULT BY HIGH PORE PRESSURE CONDITIONS.
2. AFTER THE EXCAVATION AREA HAS BEEN PROOF-ROLLED AND TESTED TO VERIFY THAT THE DESIRED DRY DENSITY HAS BEEN OBTAINED, THE AREA MAY BE FILLED TO THE DESIRED GRADES. FILL SHOULD BE PLACED IN UNIFORM LAYERS NOT EXCEEDING 12 INCHES IN LOOSE THICKNESS. EACH LAYER SHOULD BE COMPACTED TO A DRY DENSITY NOT LESS THAN 98 PERCENT OF ITS MODIFIED PROCTOR (ASTM D1557) MAXIMUM VALUE.

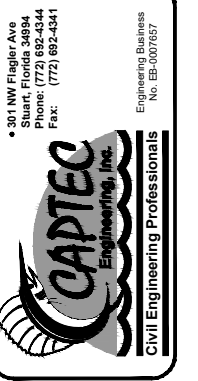

DATE: 8-24-22	DRAWN BY: MDB	DESIGNED BY: MJB	CHECKED BY: JWC	PROJECT NO.: 2032	HORIZ. SCALE: N/A	VERT. SCALE: N/A	CADD FILE:
---------------	---------------	------------------	-----------------	-------------------	-------------------	------------------	------------

NO.	DATE	BY	REVISIONS
1.	08-14-24	MDB	BID SET



TOM MACKIE BLVD. EXTENSION
CITY OF PORT ST. LUCIE, FLORIDA

GENERAL NOTES

Joseph W. Capra
301 N.W. Flagler Ave.
Stuart, Florida 34994
P.E. No. 37638

10 DAYS PRIOR TO CROSSING EXISTING CONFLICTS, THE CONTRACTOR WILL POTHOLE THE LOCATION OF ALL EXISTING UTILITIES TO DETERMINE THE EXACT HORIZONTAL AND VERTICAL LOCATIONS.

PSLUSD # 11-900-23

Printed Date:
JOB No.: 2032
SHEET 4 OF 34

P:\2000\2032 - PSL Hegener Drive Phase 3\DWG\2032 Gen Notes.dwg, 5/17/2024 11:31:02 AM

P:\2000\2032 - PSL Hegener Drive Phase 3\DWG\2032-ero.dwg, 5/17/2024 11:31:11 AM

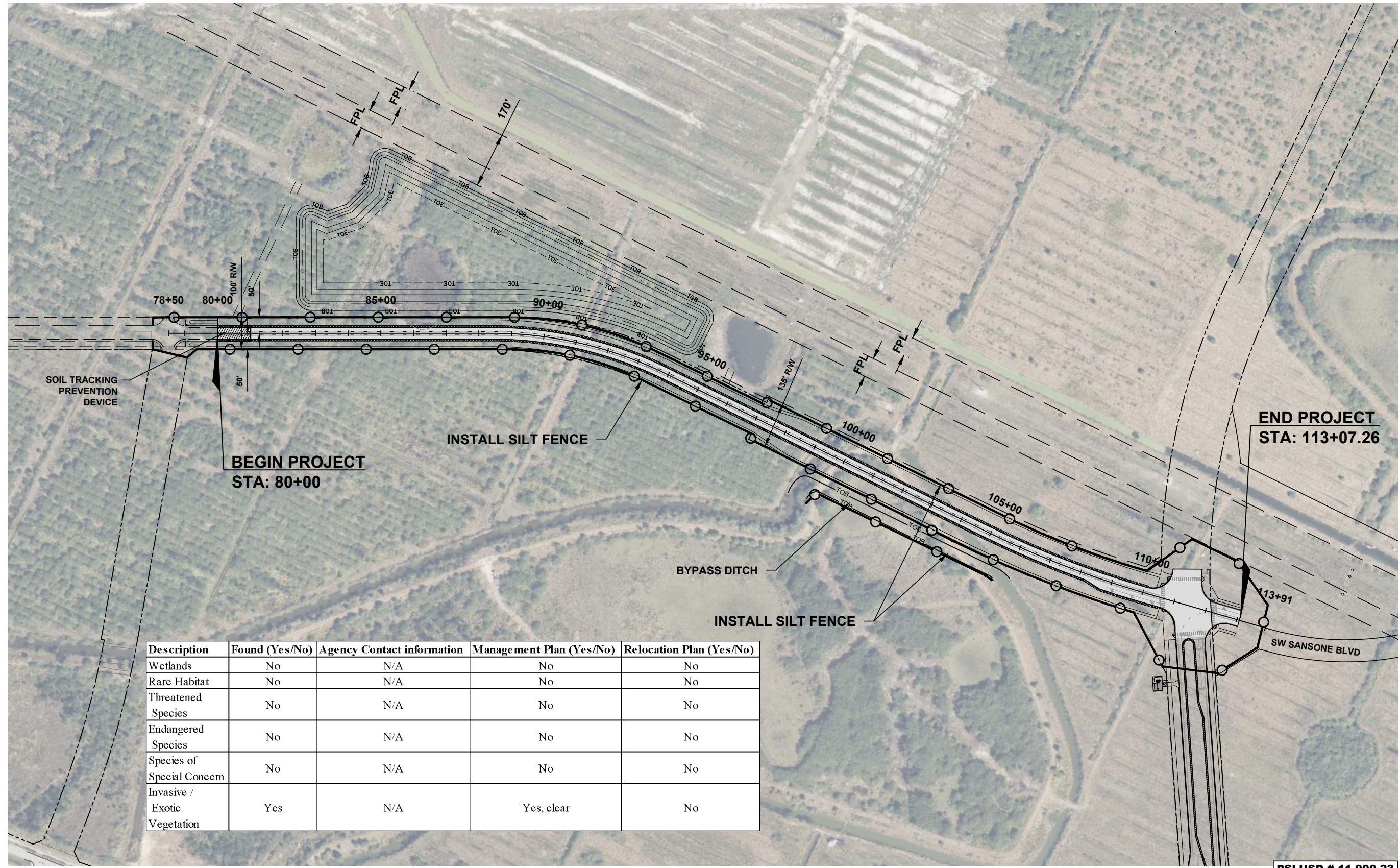
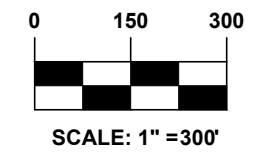

Description	Found (Yes/No)	Agency Contact information	Management Plan (Yes/No)	Relocation Plan (Yes/No)
Wetlands	No	N/A	No	No
Rare Habitat	No	N/A	No	No
Threatened Species	No	N/A	No	No
Endangered Species	No	N/A	No	No
Species of Special Concern	No	N/A	No	No
Invasive / Exotic Vegetation	Yes	N/A	Yes, clear	No

301 N.W. Flagler Ave.
 Stuart, Florida 34994
 Phone: (772) 892-4344
 Fax: (772) 892-4341

CAPTEC
 Engineering, Inc.
 Civil Engineering Professionals

DATE: 8-24-22

DRAWN BY:	MDB
DESIGNED BY:	JWC
CHECKED BY:	JWC
PROJECT NO.:	2032
HORIZ. SCALE:	1" = 300'
VERT. SCALE:	
CADD FILE:	

NO.	DATE	BY	REVISIONS
1	05-14-24	MDB	BID SET

SCALE VERIFICATION

0 0.5 1 1.5
 SOLID BAR IS EQUAL TO HALF AN INCH ON DIMENSIONS
 TO ADJUST ALL SCALED DIMENSIONS ACCORDINGLY

TOM MACKIE BLVD. EXTENSION
 CITY OF PORT ST. LUCIE, FLORIDA
EROSION AND SEDIMENT CONTROL

Joseph W. Capra
 301 N.W. Flagler Ave.
 Stuart, Florida 34994
 P.E. No. 37638

Printed Date:

JOB No.: 2032
 SHEET
5 OF **34**

PSLUSD # 11-900-23

PSL # P24-010

Section 1	Project Name and location information:	TOM MACKIE BLVD. EXTENSION. SWALE ROAD WITH DRAINAGE INLETS, PIPING. WATER UTILITY EXTENSION.
Section 2	Describe the nature of the construction activity:	CONSTRUCT ROADWAY, DRAINAGE AND UTILITY
Section 3	Describe the intended sequence of major soil disturbing activities:	EARTHWORK ENTAILS EXCAVATION OF SOILS WITHIN ROAD RIGHT OF WAY FOR ROAD CONSTRUCTION, SIDEWALK, DRAINAGE AND UTILITY.
Section 4	Total area of the site:	10.77 ACRE
Section 5	Total area of the site to be disturbed:	10.77 ACRE
Section 6	Existing data describing the soil or quality of any stormwater discharge from the site:	Borings encountered a highly variable soil profile consisting of about 1-5 feet of loose fine sands, followed by loose to medium dense slightly clayey to clayey fine sands to depths of about 8-13 feet below grade, in turn followed by loose to medium dense fine sands to depths of about 17-18 feet below grade. At this depth, very loose slightly silty fine sands were encountered to the termination depths of our borings. Further, a number of our borings encountered isolated "pockets" of loose to medium dense plastic very clayey fine sands, typically starting at depths of about 3-5 feet below grade and with thicknesses ranging from 2-4 feet.
Section 7	Estimate the drainage area size for each discharge point:	N/A
Section 8	Latitude and longitude of each discharge point and identify the receiving water or MS4 for each discharge point:	N 27° 14' 22.24" W 80° 24' 58.69"
Section 9	Give a detailed description of all controls, Best Management Practices (BMPs) and measures that will be implemented at the construction site for each activity identified in the intended sequence of major soil disturbing activities section. Provide time frames in which the controls will be implemented. NOTE: All controls shall be consistent with performance standards for erosion and sediment control and stormwater treatment set forth in s. 62-40.432, F.A.C., the applicable Stormwater or Environmental Resource Permitting requirements of the Department or a Water Management District, and the guidelines contained in the State of Florida Erosion and Sediment Control Designer and Reviewer Manual, FDOT, FDEP, and any subsequent amendments.	
		SILT FENCE TO BE PLACED ALONG PERIMETER OF CONSTRUCTION FOR DURATION OF PROJECT. TEMPORARY INLET PROTECTION WILL BE PLACED AT ALL PROPOSED STORMWATER FACILITIES DURING CONSTRUCTION. TURBIDITY BARRIER WILL BE PLACED WITHIN DITCHES IN AREAS WHERE PROPOSED STORMWATER FACILITIES WILL DISRUPT DITCHES.
Section 10	Describe all temporary and permanent stabilization practices. Stabilization practices include temporary seeding, mulching, permanent seeding, geotextiles, sod stabilization, vegetative buffer strips, protection of trees, vegetative preservations, etc.	
		ALL DISTURBED SOILS ARE TO BE STABILIZED IMMEDIATELY AFTER CONSTRUCTION IS COMPLETED WITH SOD.
Section 11	Describe all structural controls to be implemented to divert stormwater flow from exposed soils and structural practices to store flows, retain sediment on-site or in any other way limit stormwater runoff. These controls include silt fences, earth dikes, diversions, swales, sediment traps, check dams, subsurface drains, pipe slope drains, level spreaders, storm drain inlet protection, rock outlet protection, reinforced soil retaining systems, gabions, coagulating agents and temporary or permanent sediment basins.	
		SILT FENCE TO BE PLACED ALONG PERIMETER OF CONSTRUCTION AREA THE DUATION OF THE PROJECT. TEMPORARY INLET PROTECTION WILL BE PLACED AT ALL PROPOSED STORMWATER FACILITIES DURING CONSTRUCTION. TURBIDITY BARRIER WILL BE PLACED WITHIN DITCHES IN AREAS WHERE PROPOSED STORMWATER FACILITIES WILL DISRUPT DITCHES.
Section 12	Describe all sediment basins to be implemented for areas that will disturb 10 or more acres at one time. The sediment basins (or an equivalent alternative) should be able to provide 3,600 cubic feet of storage for each acre drained. Temporary sediment basins (or an equivalent alternative) are recommended for drainage areas under 10 acres.	
		SWALES CREATED BY SLOPES TYING INTO EXISTING GRADE WILL DIRECT WATER TO PROPOSED STORMWATER FACILITIES OR COLLECT AND SHEETFLOW TO EXISTING CANAL
Section 13	Describe all permanent stormwater management controls such as, but not limited to, detention or retention systems or vegetated swales that will be installed during the construction process.	
		N/A

Section 14	Waste disposal, this may include construction debris, chemicals, litter, and sanitary wastes:	ALL CONSTRUCTION MATERIALS AND DEBRIS WILL BE PLACED IN A DUMPSTER AND HAULED OFF SITE TO A LANDFILL OR OTHER PROPER DISPOSAL SITE. NO MATERIALS WILL BE BURIED ON SITE.
Section 15	Offsite vehicle tracking from construction entrances/exits:	OFF SITE VEHICLE TRACKING OF SEDIMENTS AND DUST GENERATION WILL BE MINIMIZED VIA A ROCK CONSTRUCTION ENTRANCE, STREET SWEEPING AND THE USE OF WATER TO KEEP DUST DOWN.
Section 16	The proper application rates of all fertilizers, herbicides and pesticides used at the construction site:	FLORIDA-FRIENDLY FERTILIZERS AND PESTICIDES WILL BE USED AT A MINIMUM AND IN ACCORDANCE WITH THE MANUFACTURER'S SUGGESTED APPLICATION RATES.
Section 17	The storage, application, generation and migration of all toxic substances:	ALL PAINTS AND OTHER CHEMICALS WILL BE STORED IN A LOCKED COVERED SHED.
Section 18	Other:	PORT-O-LETS WILL BE PLACED AWAY FROM STORM SEWER SYSTEMS, STORM INLET(S), SURFACE WATERS AND WETLANDS. NO VEHICLE MAINTENANCE SHALL BE CONDUCTED ON-SITE. A WASHDOWN AREA SHALL BE DESIGNATED AT ALL TIMES AND WILL NOT BE LOCATED IN ANY AREA THAT WILL ALLOW FOR THE DISCHARGE OF POLLUTED RUNOFF.
Section 19	Provide a detailed description of the maintenance plan for all structural and non-structural controls to assure that they remain in good and effective operating condition.	
		CONTRACTOR SHALL PROVIDE ROUTINE MAINTENANCE OF PERMANENT AND TEMPORARY SEDIMENT AND EROSION CONTROL FEATURES IN ACCORDANCE WITH THE TECHNICAL SPECIFICATIONS OR AS FOLLOWS, WHICHEVER IS MORE STRINGENT: <ul style="list-style-type: none"> • SILT FENCE SHALL BE INSPECTED AT LEAST WEEKLY. ANY REQUIRED REPAIRS SHALL BE MADE IMMEDIATELY. SEDIMENT DEPOSITS SHALL BE REMOVED WHEN THEY REACH APPROXIMATELY ONE-HALF THE HEIGHT OF THE BARRIER. • MAINTENANCE SHALL BE PERFORMED ON THE ROCK ENTRANCE WHEN ANY VOID SPACES ARE FULL OF SEDIMENT. • INLET(S)/OUTFALLS SHALL BE INSPECTED IMMEDIATELY AFTER EACH RAIN EVENT AND ANY REQUIRED REPAIRS TO THE FILTER INLETS, SILT FENCE, OR FILTER FABRIC SHALL BE PERFORMED IMMEDIATELY. • BARE AREAS OF THE SITE THAT WERE PREVIOUSLY SEEDED SHALL BE RESEED PER MANUFACTURES' INSTRUCTIONS. • MULCH AND SOD THAT HAS BEEN WASHED OUT SHALL BE REPLACED IMMEDIATELY. • MAINTAIN ALL OTHER AREAS OF THE SITE WITH PROPER CONTROLS AS NECESSARY.
Section 20	Inspections: Describe the inspection and inspection documentation procedures, as required by the FDEP NPDES Generic Permit for Stormwater Discharge from Large and Small Construction Activities.	
		QUALIFIED PERSONNEL WILL INSPECT ALL POINTS OF DISCHARGES, ALL DISTURBED AREAS OF CONSTRUCTION THAT HAVE NOT BEEN STABILIZED, CONSTRUCTED AREAS AND LOCATIONS WHERE VEHICLES ENTER AND EXIT THE SITE, AND ALL BMPS AT LEAST ONCE EVERY 7 CALENDAR DAYS AND WITHIN 24 HOURS OF THE END OF A RAINFALL EVENT THAT IS 0.5 INCHES OR GREATER. WHERE SITES HAVE BEEN FINALLY STABILIZED, SAID INSPECTIONS SHALL BE CONDUCTED AT LEAST ONCE EVERY MONTH UNTIL THE NOTICE OF TERMINATION IS FILED.
Section 21	Identify and describe all sources of non-stormwater discharges as allowed by the FDEP NPDES Generic Permit for Stormwater Discharge from Large and Small Construction Activities.	
Section 22	All contractor(s) and subcontractor(s) identified in the SWPPP must sign the following certification:	
		"I certify under penalty of law that I understand, and shall comply with, the terms and conditions of the State of Florida Generic Permit for Stormwater Discharge from Large and Small Construction Activities and this Stormwater Pollution Prevention Plan prepared thereunder."

Section 22	Name	Title	Company Name, Address and Phone Number	Date

**RECOMMENDATIONS FROM
ROADWAY SOIL SURVEY AND GEOTECHNICAL ENGINEERING EVALUATION HEGENER DRIVE - PHASE III
AAE FILE NO. 22-186 ANDERSEN ANDRE CONSULTING ENGINEERS, INC.**

7.1 Site Clearing and Ditch/Wetland Reclamation

The areas to be paved, within lines five feet outside construction perimeters, should be cleared, grubbed and stripped of all surface vegetation, trash, debris and topsoil. Stumps (if any) should be removed entirely. Overall, any clearing and preparation of the construction site should be performed in accordance with Section 110 "Clearing and Grubbing" of the FDOT Standard Specifications for Road and Bridge Construction, latest version (FDOT Standard Specs).

As previously noted, two agricultural drainage ditches and a portion of a wetland feature will need to be partially reclaimed and, based on our penetrometer probing within these ditches, 2-3 feet of soft, unsuitable materials are currently present and will need to be removed. Further, approximately 1 foot of organic material is present along the banks of the ditches which will need to be removed as well. For this purpose, consideration can be given to constructing temporary ditch cofferdams to isolate the subject segments of the ditches and then use pumps and bypass hoses to create a dry working environment. The design and construction of any cofferdams and dewatering systems will be the responsibility of the earthwork contractor. Further, decommissioning of dewatering systems should be addressed in the contractor's dewatering submittal. Water from dewatering pumps should be discharged as far as practically possible away from the work areas to prevent return flow and/or erosion.

The reclamation of the ditches should be done in accordance with applicable State and Federal requirements and guidelines. The recommendations and definitions in OSHA 29 C.F.R. Part 1926 Subpart P "Excavations" and the Florida Trench Safety Act should be reviewed and utilized for any subsurface efforts. Excavated materials should not be stockpiled at the edge of the excavations within a horizontal distance equal to the excavation depth.

Once the bottom of a ditch or wetland segment is inspected and approved, select backfill can be placed in 12-inch lifts (loose thickness) and compacted with a vibratory roller to a dry density of at least 100 percent of the standard Proctor maximum dry density (AASHTO T-99) of the compacted material to depths of 1 foot below the compacted surface.

7.2 Roadway Construction

The roadway embankment design and construction should adhere to the requirements of FDOT Standard Plans Index 120-001 and Section 120 of the FDOT Standard Specs.

Embankment fill should be compacted to 100 percent of the standard Proctor maximum dry density (AASHTO T-99). Per the soil borings presented herein, the majority of the encountered soils throughout the site consist of A-3 and A-2-4 which are both considered "select" materials with respect to the FDOT Standard Plans Index 120-001.

However, we note that a number of our borings encountered isolated "pockets" of loose to medium dense plastic very clayey fine sands (A-2-6), typically starting at depths of about 3-5 feet below grade and with thicknesses ranging from 2-4 feet. Considering that the roadway alignment will likely be raised 3-4 feet, these plastic soils can likely remain in place. However, if plastic soils are encountered at shallower depths (within 4 feet of the bottom of the proposed base course) during the site preparation or in utility excavations, they should be removed in accordance with the FDOT Standard Plans Index 120-001.

We note that, based on our experience with soils in the vicinity of the subject site, careful and thorough proofrolling of the pavement areas is imperative. We strongly recommend that an AACE representative be on-site during all proofrolling activities for the purpose of identifying soft, yielding areas potentially indicating shallow compressible soils. These areas, once identified, can then be immediately addressed through excavation and replacement with suitable sand backfill without significantly impacting the construction schedule.

Failure to carefully monitor proofrolling could result in the aforementioned compressible soils being left in-place, perhaps resulting in poor pavement performance. Overall, during proof-rolling, it is recommended that the roadway construction areas receive no less than 10 passes with a vibratory roller, with each pass overlapping the previous by at least 30 percent.

After clearing and proofrolling the site surface, and properly reclaiming the aforementioned ditch sections and wetland areas, as previously recommended, the surficial soils should be suitable to support the embankment and proposed pavement section. A minimum of 18 inches should separate the bottom of the pavement base from the estimated normal seasonal high water table elevation.

7.3 Utility and Drainage Construction

It is noted that the shallow subsoils consist mostly of clayey sands with a thin, surficial mantle of relatively clean sands, with these clayey sands encountered to depths of 8-13 below the existing grades. Due to the elevated fines content of the clayey soils and their resulting tendency to retain excessive moisture, these site soils will be problematic if the contractor intends to excavate the soils and immediately (or shortly thereafter) return the soils to the excavation as backfill.

If the on-site soils discussed herein are to be used as pipe trench backfill, it will be necessary to stockpile the moist, clayey soils for extended periods to allow for some degree of drying coupled with mechanical manipulation to further reduce moisture levels. Additionally, it will also likely be necessary to mix the soils with imported, dry, free-draining sandy soils with a much lower fines content (preferably 5% or less) to reduce the final percent fines to less than 12 percent. As such, to facilitate the construction schedule, it may be necessary to import clean, free-draining fine sand for use as pipe trench backfill. Alternatively, our soil borings completed within the proposed water management tract encountered relatively clean sands at various depths, particularly below depths of about 25 feet.

Excavations made through the clayey soils may have to be deepened and backfilled partially with gravel to allow creating a firm bottom. The utility (and drainage) trench backfill should be placed in level lifts of 12 inches, with each lift compacted to a dry density of 98 percent of the modified Proctor (ASTM D1557) maximum dry density. Refer to the City of Port St. Lucie Utility Standards Manual (latest edition) for specific requirements for utility installations, including quality control.

PSLUSD # 11-900-23

**301 N.W. Flagler Ave.
Stuart, Florida 34994
Phone: (772) 892-4344
Fax: (772) 892-4341**

**Engineering Business
No. EB-007657**

CAPTEC
Engineering, Inc.
Civil Engineering Professionals

DATE: 8-24-22
DRAWN BY: MDB
DESIGNED BY: MDB
CHECKED BY: JWC
PROJECT NO.: 2032
HORIZ. SCALE: N/A
VERT. SCALE: N/A
CADD FILE:

NO.	DATE	BY	REVISIONS
1	04-22-24	MDB	FINAL PLANS

SCALE VERIFICATION
0 0.5
SOLID BAR IS EQUAL TO HALF AN INCH ON ADJUST ALL SCALED DIMENSIONS ACCORDINGLY

**TOM MACKIE BLVD.
EXTENSION**
CITY OF PORT ST. LUCIE, FLORIDA

EROSION CONTROL NOTES

Joseph W. Capra
301 N.W. Flagler Ave.
Stuart, Florida 34994
P.E. No. 37638

Printed Date:

JOB No.: 2032
SHEET
6 OF **34**

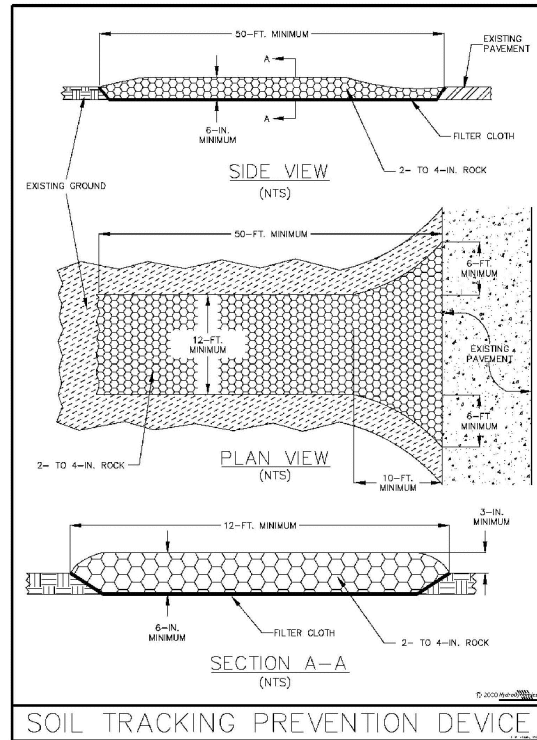

Figure V-52: Illustration of a Soil Tracking Prevention Device

Permission is given by Hydrus/Dynamics Incorporated to copy and reproduce this detail.

V-31

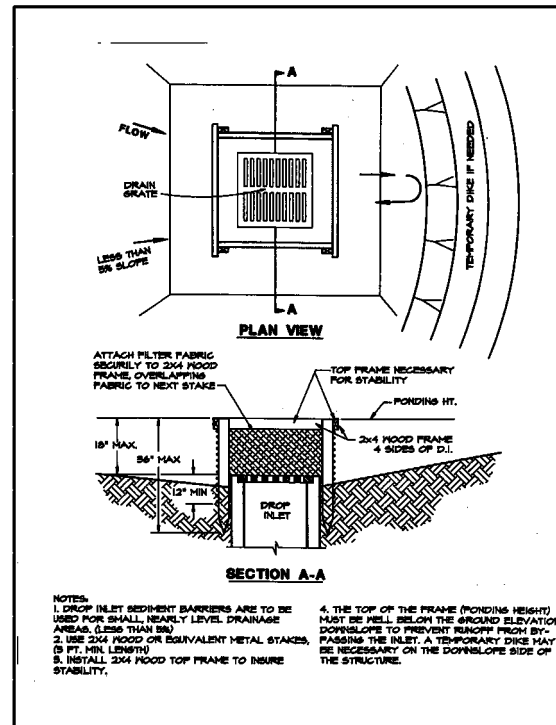

Figure 4.5a. Silt Fence Drop Inlet Sediment Barrier

Source: Erosion Draw

77

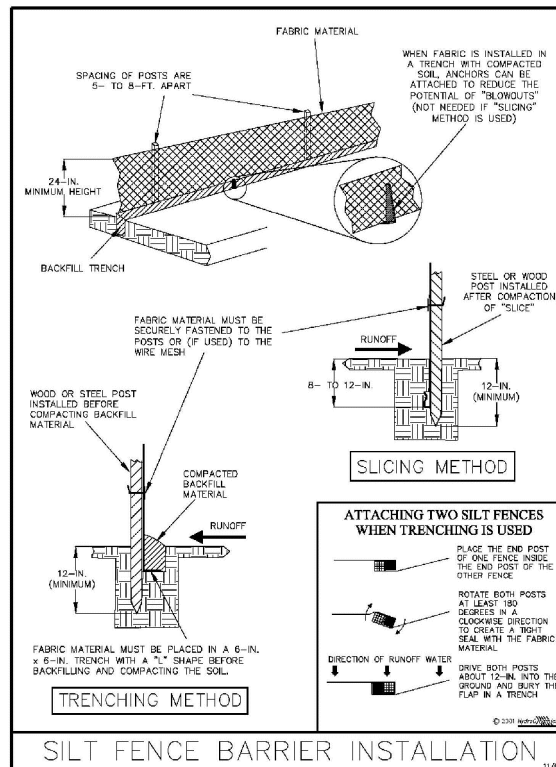

Figure V-40: Illustration of a Silt Fence Barrier

Permission is given by Hydrus/Dynamics Incorporated to copy and reproduce this detail.

V-7

301 NW Flagler Ave.
Stuart, Florida 34994
Phone: (772) 892-4344
Fax: (772) 892-4341

CAPTEC
Engineering, Inc.
Civil Engineering Professionals

DATE: 8-24-22
DRAWN BY: MDB
DESIGNED BY: JWC
CHECKED BY: JWC
PROJECT NO.: 2032
HORIZ. SCALE: N/A
VERT. SCALE: N/A
CADD FILE:

NO.	DATE	BY	REVISIONS
1	04-22-24	MDB	FINAL PLANS

SCALE VERIFICATION

0 0.5 1

SOLID BAR IS EQUAL TO HALF AN INCH ON DIMENSIONS. ADJUST ALL SCALED DIMENSIONS ACCORDINGLY.

TOM MACKIE BLVD. EXTENSION
CITY OF PORT ST. LUCIE, FLORIDA

EROSION CONTROL DETAILS

Joseph W. Capra
301 N.W. Flagler Ave.
Stuart, Florida 34994
P.E. No. 37638

Printed Date:

JOB No.: 2032
SHEET 7 OF 34

PSLUSD # 11-900-23

PSL # P24-010

P:\2000\2032 - PSL Hegener Drive Phase 3\Draw\2032-ero NOTES.dwg, 5/17/2024 11:31:19 AM

P:\2000\2032 - PSL Hegener Drive Phase 3\DWG\2032 MACKIE DRMAP.dwg, 5/17/2024 11:31:35 AM

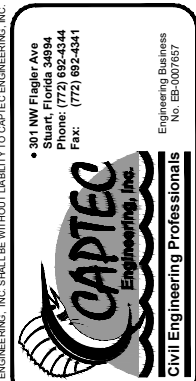
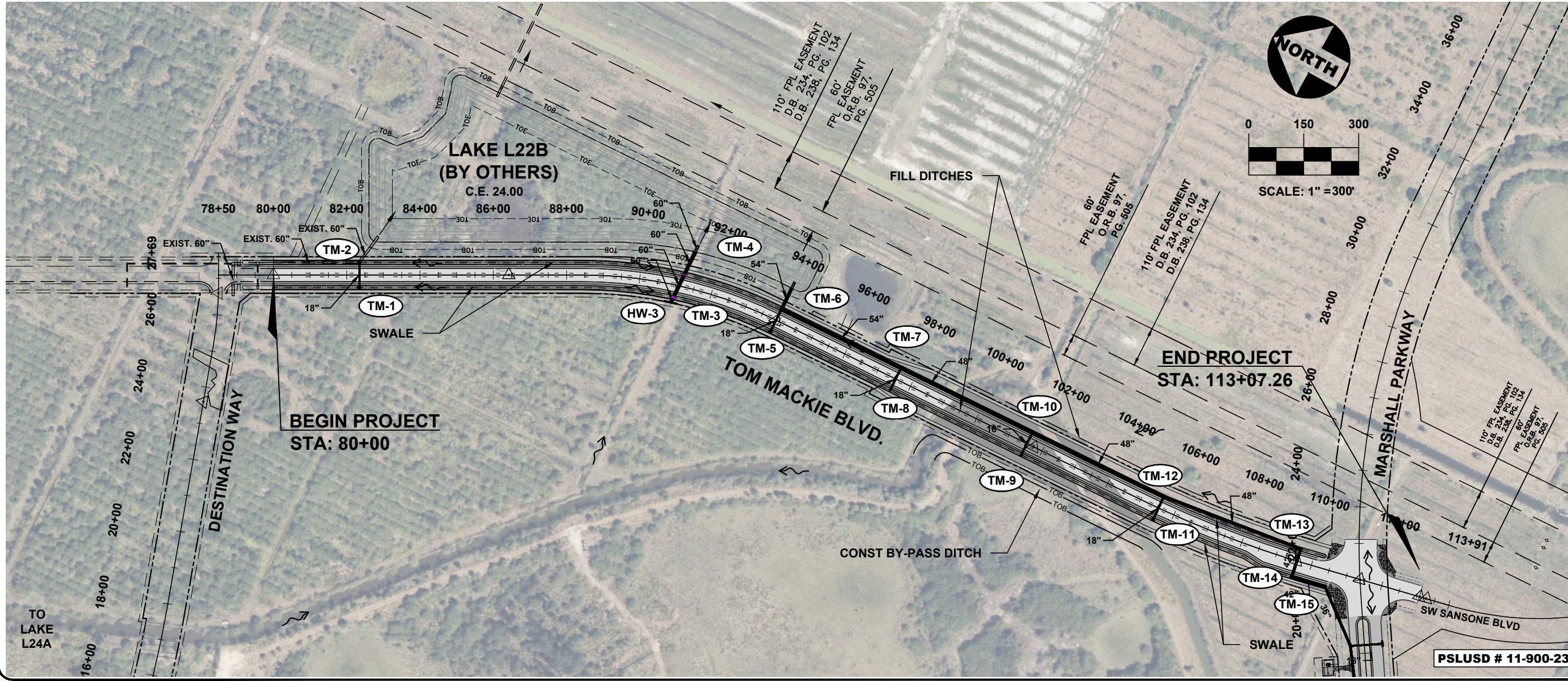
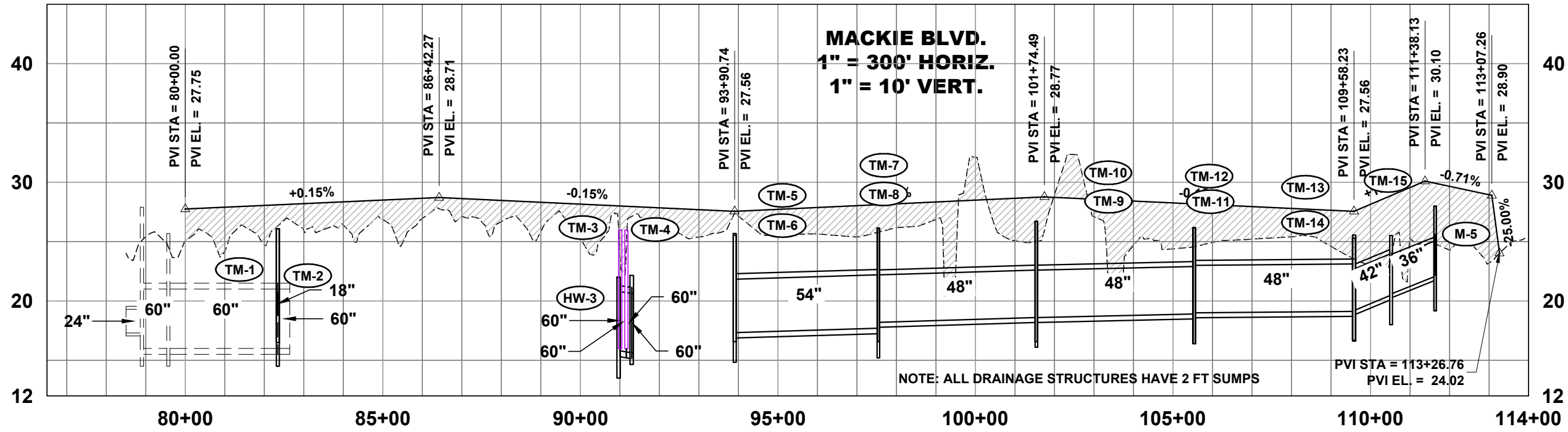

DATE:	8-24-22
DRAWN BY:	MDB
DESIGNED BY:	MDB
CHECKED BY:	JWC
PROJECT NO.:	2032
HORIZ. SCALE:	1" = 300'
VERT. SCALE:	1" = 10'
CADD FILE:	

NO.	DATE	BY	REVISIONS
1	08-14-24	MDB	BID SET

SCALE VERIFICATION	0.5
SOLID BAR IS EQUAL TO HALF AN INCH ON ADJUST ALL SCALED DIMENSIONS ACCORDINGLY	

TOM MACKIE BLVD. EXTENSION
 CITY OF PORT ST. LUCIE, FLORIDA
DRAINAGE MAP

Joseph W. Capra
 301 N.W. Flagler Ave.
 Stuart, Florida 34994
 P.E. No. 37638

Printed Date:
 JOB No.: 2032
 SHEET
8 OF **34**

PSL # P24-010

P:\2000\2032 - PSL Hegener Drive Phase 3\DWG\2032-PLANS.dwg, 5/17/2024 11:31:51 AM

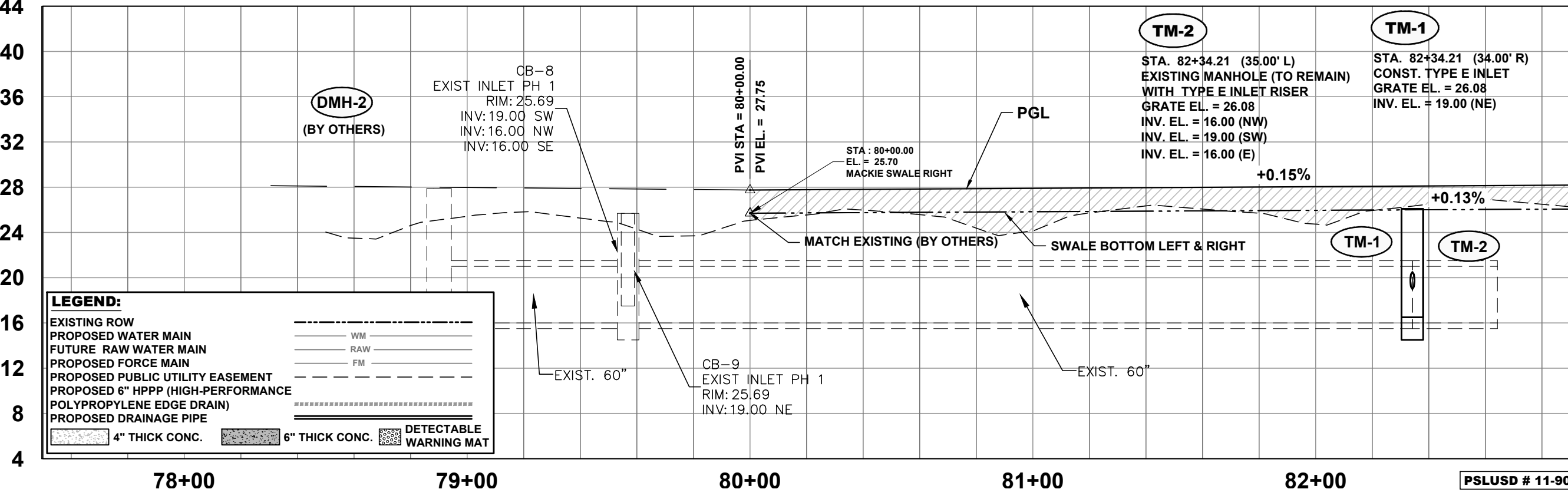
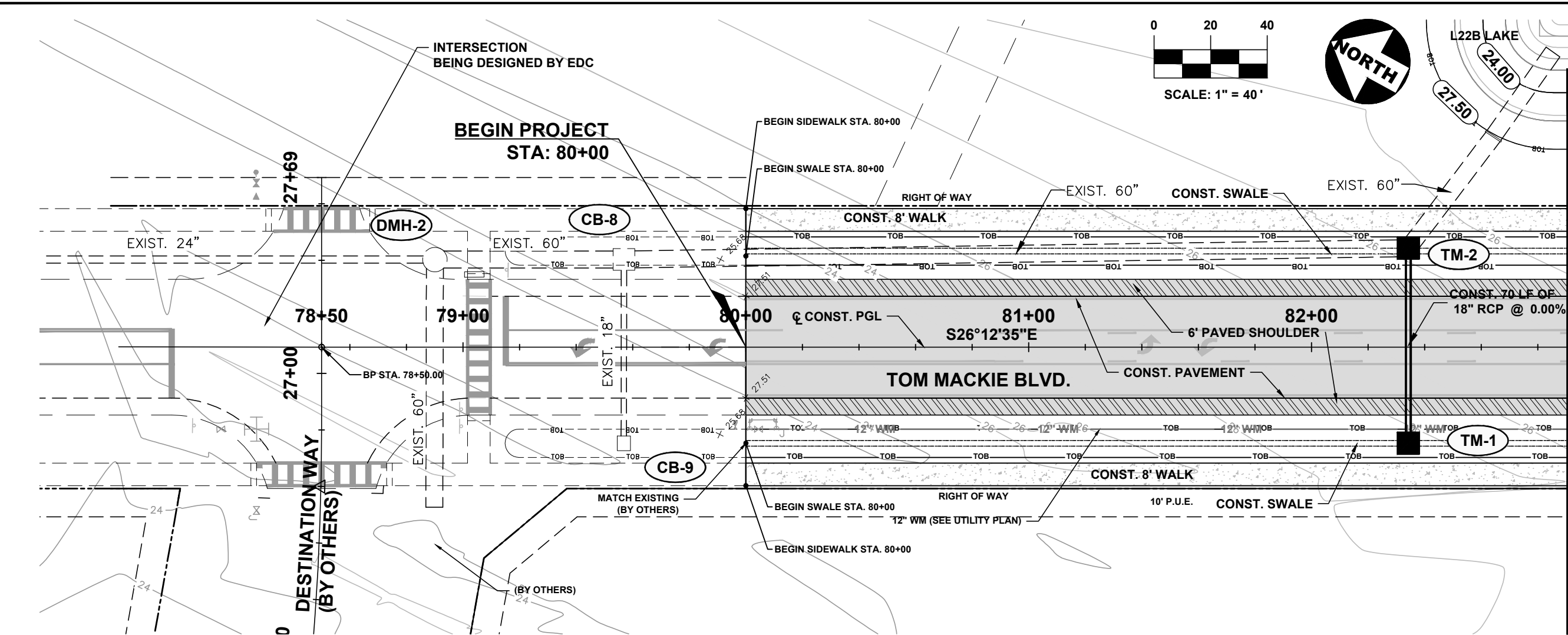

MATCH LINE STA: 82+90 (SEE SHEET 10)

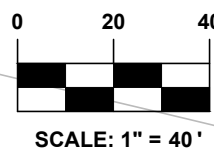

301 NW Flagler Ave.
Stuart, Florida 34994
Phone: (772) 892-4344
Fax: (772) 892-4341

Engineering Business
No. EB-007857
Civil Engineering Professionals

DATE:	8-24-22
DRAWN BY:	MDB
DESIGNED BY:	MDB
CHECKED BY:	###
PROJECT NO.:	2032
HORIZ. SCALE:	1" = 40'
VERT. SCALE:	1" = 10'
CADD FILE:	

NO.	DATE	BY	REVISIONS
1.	05-14-24	MDB	BID SET

SCALE VERIFICATION

SOLID BAR IS EQUAL TO HALF AN INCH ON DRAWING TO ADJUST ALL SCALED DIMENSIONS ACCORDINGLY

TOM MACKIE BLVD. EXTENSION
CITY OF PORT ST. LUCIE, FLORIDA

PLAN AND PROFILE

Joseph W. Capra
301 N.W. Flagler Ave.
Stuart, Florida 34994
P.E. No. 37638

Printed Date: _____

JOB No.:	2032
SHEET	9
OF	34

PSLUSD # 11-900-23

P:\2000\2032 - PSL Hegener Drive Phase 3\DWG\2032-PLANS.dwg, 5/17/2024 11:31:55 AM

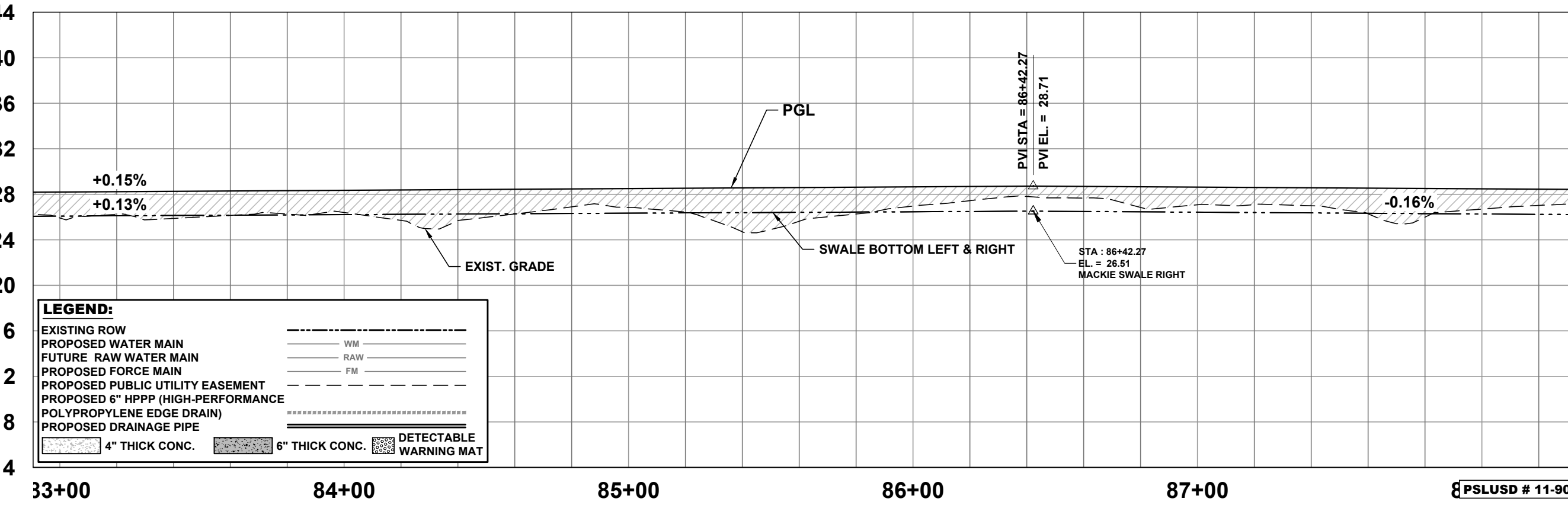
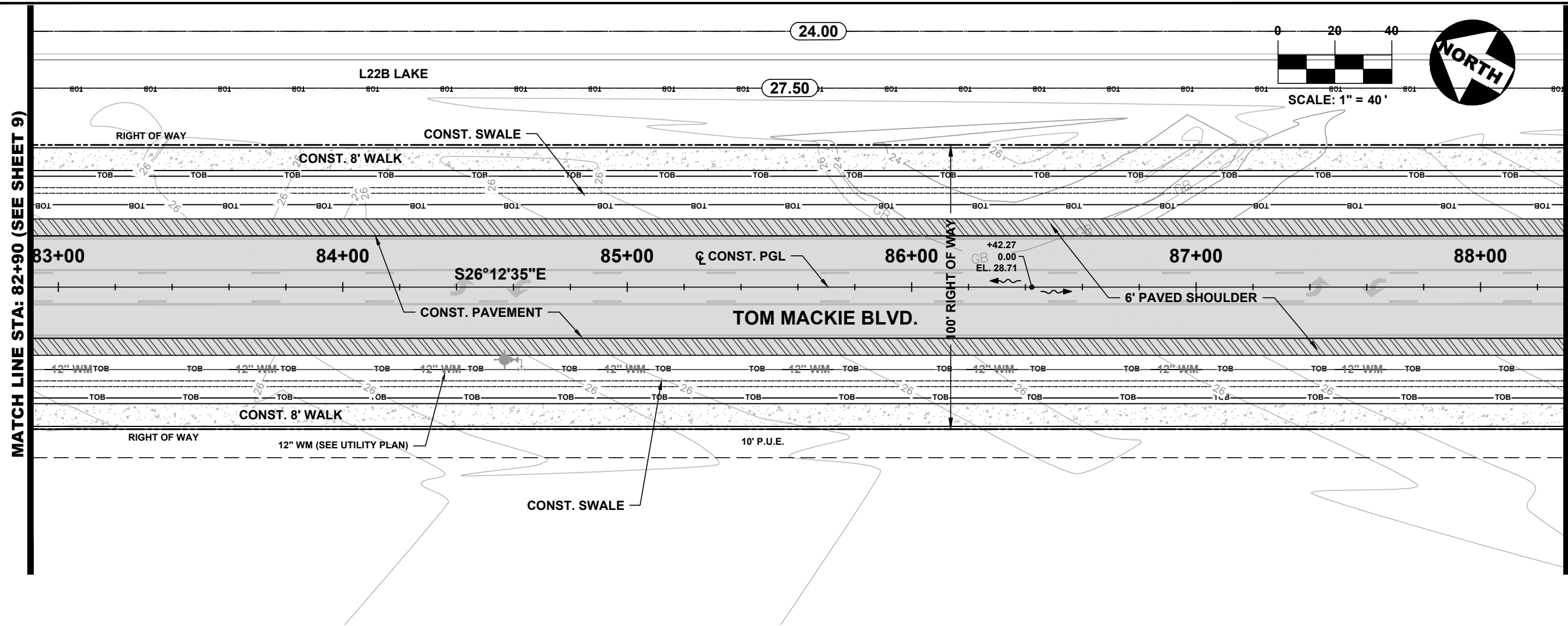

LEGEND:

EXISTING ROW	---
PROPOSED WATER MAIN	WM
FUTURE RAW WATER MAIN	RAW
PROPOSED FORCE MAIN	FM
PROPOSED PUBLIC UTILITY EASEMENT	---
PROPOSED 6" HPPP (HIGH-PERFORMANCE POLYPROPYLENE EDGE DRAIN)	=====
PROPOSED DRAINAGE PIPE	=====
4" THICK CONC.	[Pattern]
6" THICK CONC.	[Pattern]
DETECTABLE WARNING MAT	[Pattern]

301 NW Flagler Ave.
 Stuart, Florida 34994
 Phone: (772) 892-4344
 Fax: (772) 892-4341

CAPTEC
 Engineering, Inc.
 Civil Engineering Professionals

Engineering Business
 No. EB-007857

DATE: 8-24-22

DRAWN BY:	MDB
DESIGNED BY:	MDB
CHECKED BY:	###
PROJECT NO.:	2032
HORIZ. SCALE:	1" = 40'
VERT. SCALE:	1" = 10'

CADD FILE:

NO.	DATE	BY	REVISIONS
1	05-14-24	MDB	BID SET

SCALE VERIFICATION

0 0.5 1

SOLID BAR IS EQUAL TO HALF AN INCH ON DRAWING. ADJUST ALL SCALED DIMENSIONS ACCORDINGLY.

TOM MACKIE BLVD. EXTENSION
 CITY OF PORT ST. LUCIE, FLORIDA

PLAN AND PROFILE

Joseph W. Capra
 301 N.W. Flagler Ave.
 Stuart, Florida 34994
 P.E. No. 37638

Printed Date:

JOB No.: 2032
 SHEET 10 OF 34

P:\2000\2032 - PSL Hegener Drive Phase 3\DWG\2032-PLANS.dwg, 5/17/2024 11:32:00 AM

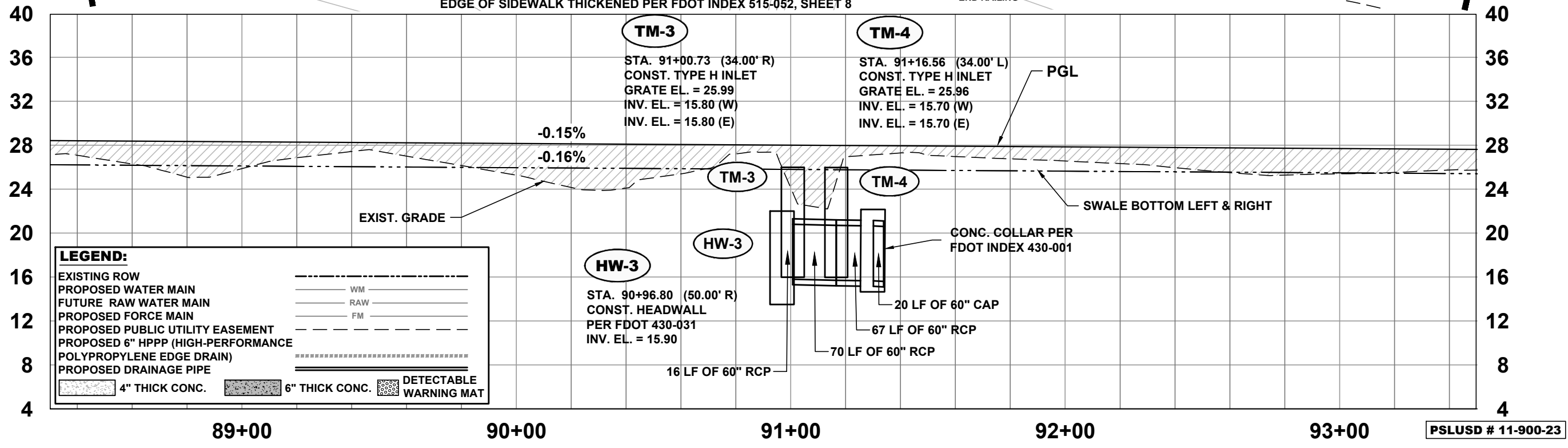
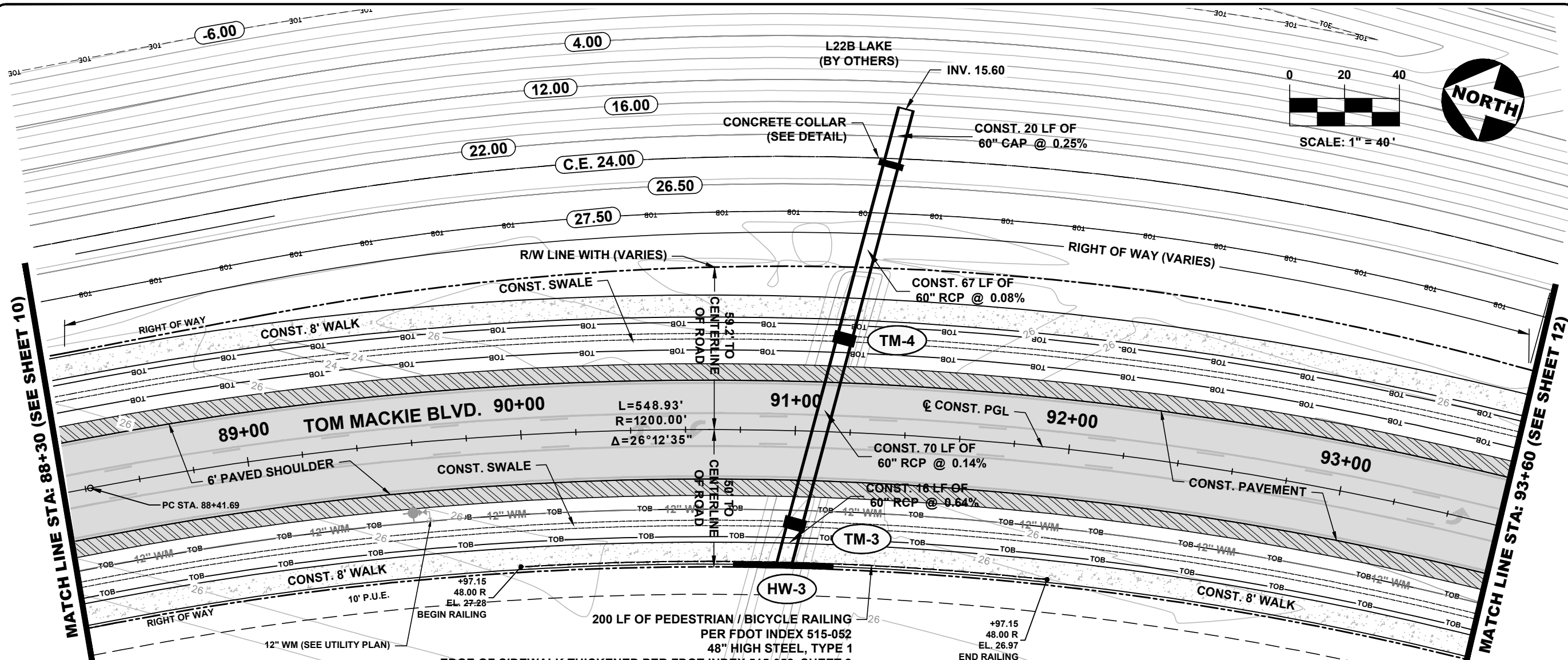

LEGEND:

EXISTING ROW	---
PROPOSED WATER MAIN	WM
FUTURE RAW WATER MAIN	RAW
PROPOSED FORCE MAIN	FM
PROPOSED PUBLIC UTILITY EASEMENT	---
PROPOSED 6" HPPP (HIGH-PERFORMANCE POLYPROPYLENE EDGE DRAIN)	-----
PROPOSED DRAINAGE PIPE	=====
4" THICK CONC.	[Pattern]
6" THICK CONC.	[Pattern]
DETECTABLE WARNING MAT	[Pattern]

301 NW Flagler Ave.
 Stuart, Florida 34994
 Phone: (772) 892-4344
 Fax: (772) 892-4341

CAPTEC
 Engineering, Inc.
 Civil Engineering Professionals

DATE: 8-24-22

DRAWN BY:	MDB
DESIGNED BY:	MDB
CHECKED BY:	###
PROJECT NO.:	2032
HORIZ. SCALE:	1" = 40'
VERT. SCALE:	1" = 10'

NO.	DATE	BY	REVISIONS
1	05-14-24	MDB	BID SET

SCALE VERIFICATION

0 0.5 1

SOLID BAR IS EQUAL TO HALF AN INCH ON TO HALF AN INCH ON ADJUST ALL SCALED DIMENSIONS ACCORDINGLY

TOM MACKIE BLVD. EXTENSION
 CITY OF PORT ST. LUCIE, FLORIDA

PLAN AND PROFILE

Joseph W. Capra
 301 N.W. Flagler Ave.
 Stuart, Florida 34994
 P.E. No. 37638

Printed Date:

JOB No.: 2032
 SHEET 11 OF 34

PSLUSD # 11-900-23

P:\2000\2032 - PSL Hegener Drive Phase 3\DWG\2032-PLANS.dwg, 5/17/2024 11:32:05 AM

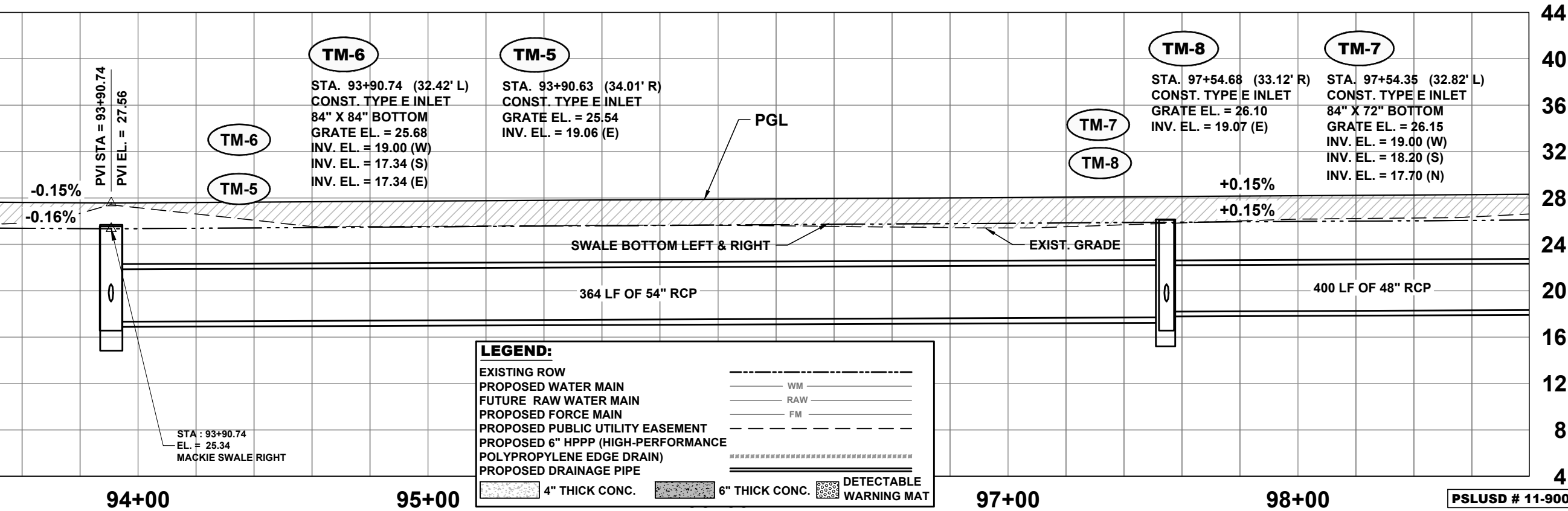
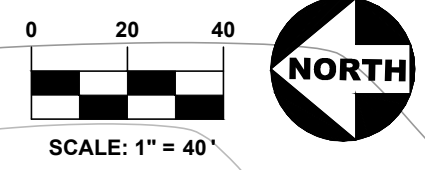
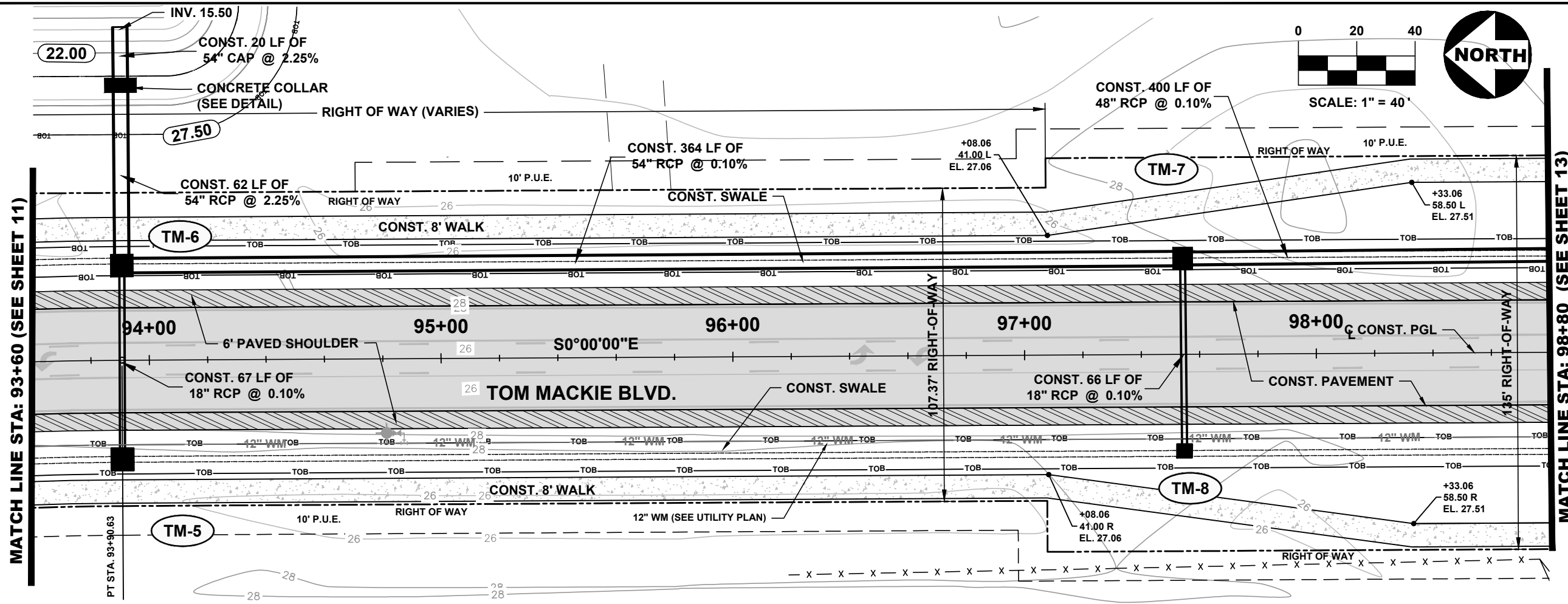

LEGEND:

EXISTING ROW	---
PROPOSED WATER MAIN	---
FUTURE RAW WATER MAIN	---
PROPOSED FORCE MAIN	---
PROPOSED PUBLIC UTILITY EASEMENT	---
PROPOSED 6" HPPP (HIGH-PERFORMANCE POLYPROPYLENE EDGE DRAIN)	=====
PROPOSED DRAINAGE PIPE	=====
4" THICK CONC.	[Pattern]
6" THICK CONC.	[Pattern]
DETECTABLE WARNING MAT	[Pattern]

301 NW Flagler Ave.
Stuart, Florida 34994
Phone: (772) 892-4344
Fax: (772) 892-4341

CAPTEC Engineering, Inc.
Civil Engineering Professionals

DATE: 8-24-22

DRAWN BY: MDB	DESIGNED BY: MDB
CHECKED BY: MDB	PROJECT NO.: 2032
VERT. SCALE: 1" = 40'	HORZ. SCALE: 1" = 40'
CADD FILE:	

NO.	DATE	BY	REVISIONS
1	05-14-24	MDB	BID SET

SCALE VERIFICATION

0 0.5 1

SOLID BAR IS EQUAL TO HALF AN INCH ON DRAWING. ADJUST ALL SCALED DIMENSIONS ACCORDINGLY.

TOM MACKIE BLVD. EXTENSION
CITY OF PORT ST. LUCIE, FLORIDA

PLAN AND PROFILE

Joseph W. Capra
301 N.W. Flagler Ave.
Stuart, Florida 34994
P.E. No. 37638

Printed Date:

JOB No.: 2032
SHEET 12 OF 34

PSL # P24-010

PSLUSD # 11-900-23

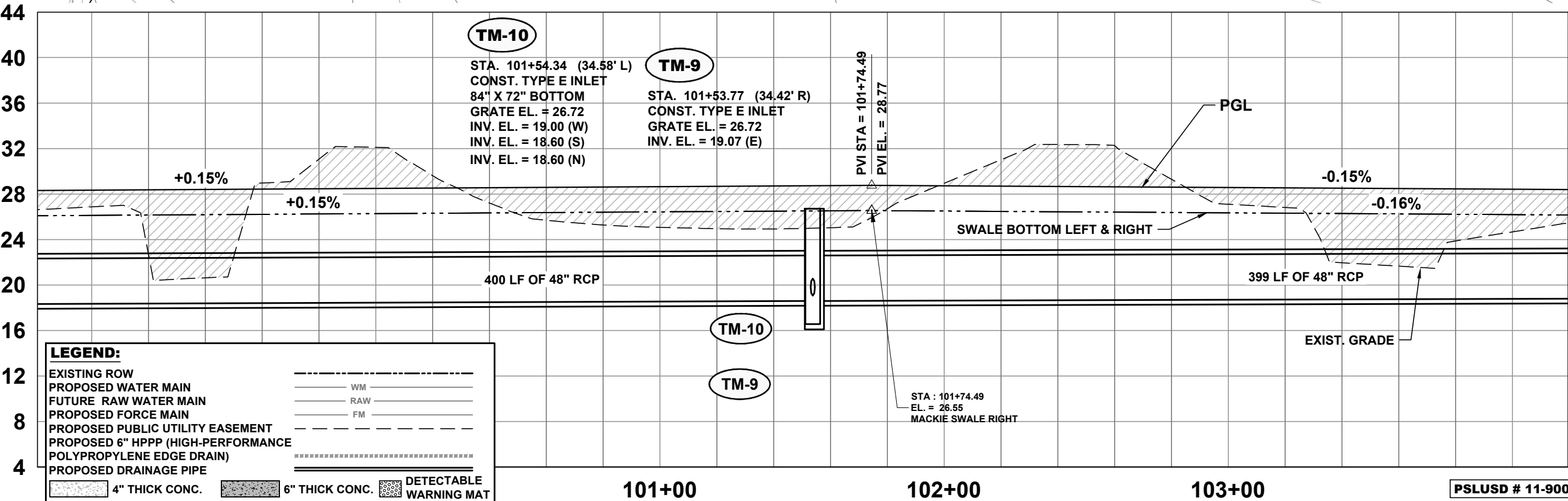
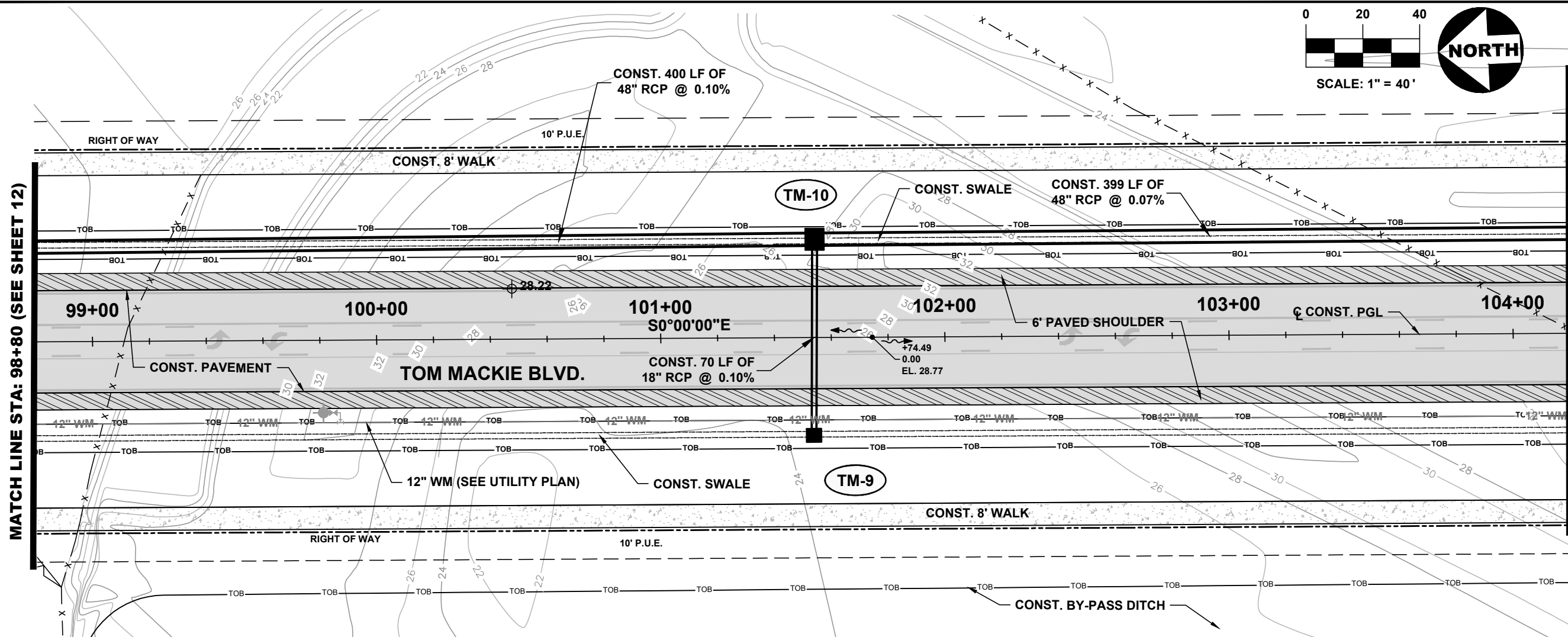

LEGEND:

EXISTING ROW	---
PROPOSED WATER MAIN	WM
FUTURE RAW WATER MAIN	RAW
PROPOSED FORCE MAIN	FM
PROPOSED PUBLIC UTILITY EASEMENT	----
PROPOSED 6" HPPP (HIGH-PERFORMANCE POLYPROPYLENE EDGE DRAIN)	=====
PROPOSED DRAINAGE PIPE	=====
4" THICK CONC.	[Pattern]
6" THICK CONC.	[Pattern]
DETECTABLE WARNING MAT	[Pattern]

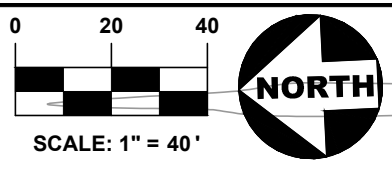

301 NW Flagler Ave.
Stuart, Florida 34994
Phone: (772) 892-4344
Fax: (772) 892-4341

CAPTEC
Engineering, Inc.
Civil Engineering Professionals

DATE: 8-24-22
DRAWN BY: MDB
DESIGNED BY: MDB
CHECKED BY: ###
PROJECT NO.: 2032
HORIZ. SCALE: 1" = 40'
VERT. SCALE: 1" = 10'
CADD FILE:

NO.	DATE	BY	REVISIONS
1	08-14-24	MDB	BID SET

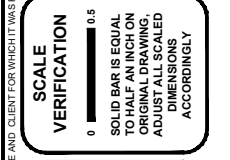

TOM MACKIE BLVD. EXTENSION
CITY OF PORT ST. LUCIE, FLORIDA

PLAN AND PROFILE

Joseph W. Capra
301 N.W. Flagler Ave.
Stuart, Florida 34994
P.E. No. 37638

Printed Date:

JOB No.: 2032
SHEET 13 OF 34

PSLUSD # 11-900-23

P:\2000\2032 - PSL Hegener Drive Phase 3\DWG\2032-PLANS.dwg, 5/17/2024 11:32:15 AM

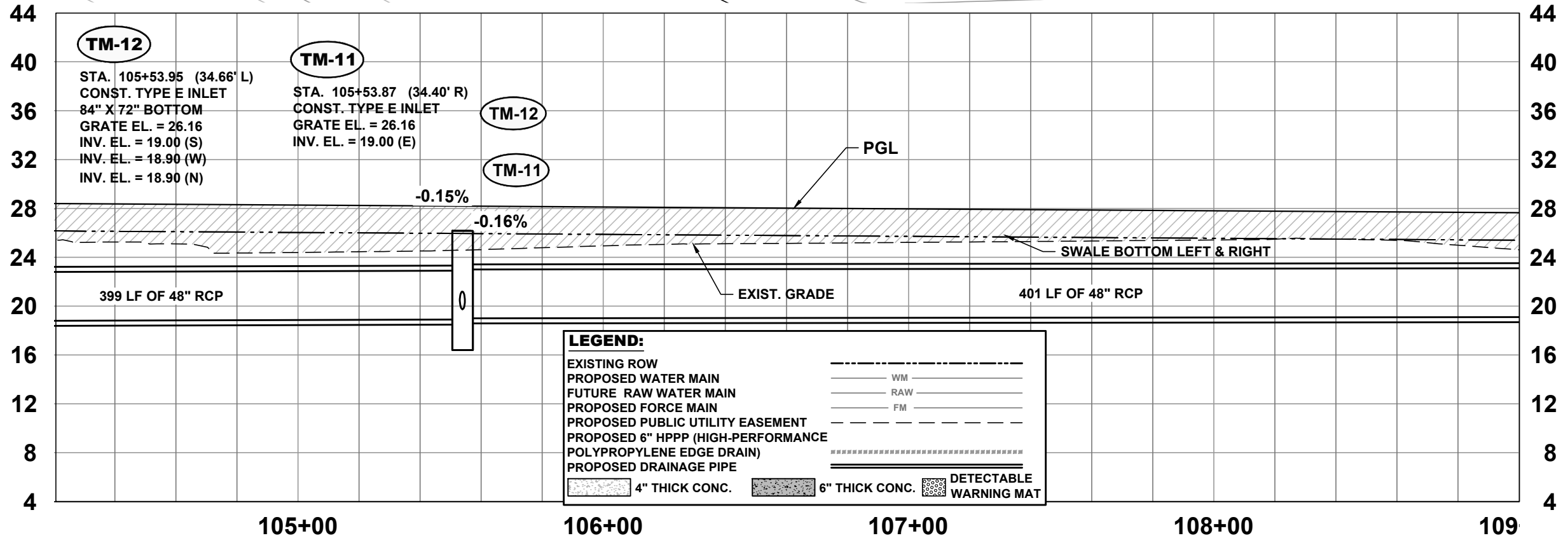
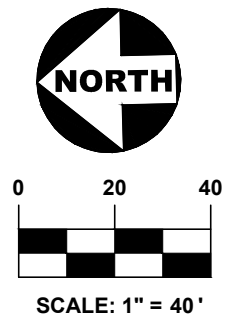
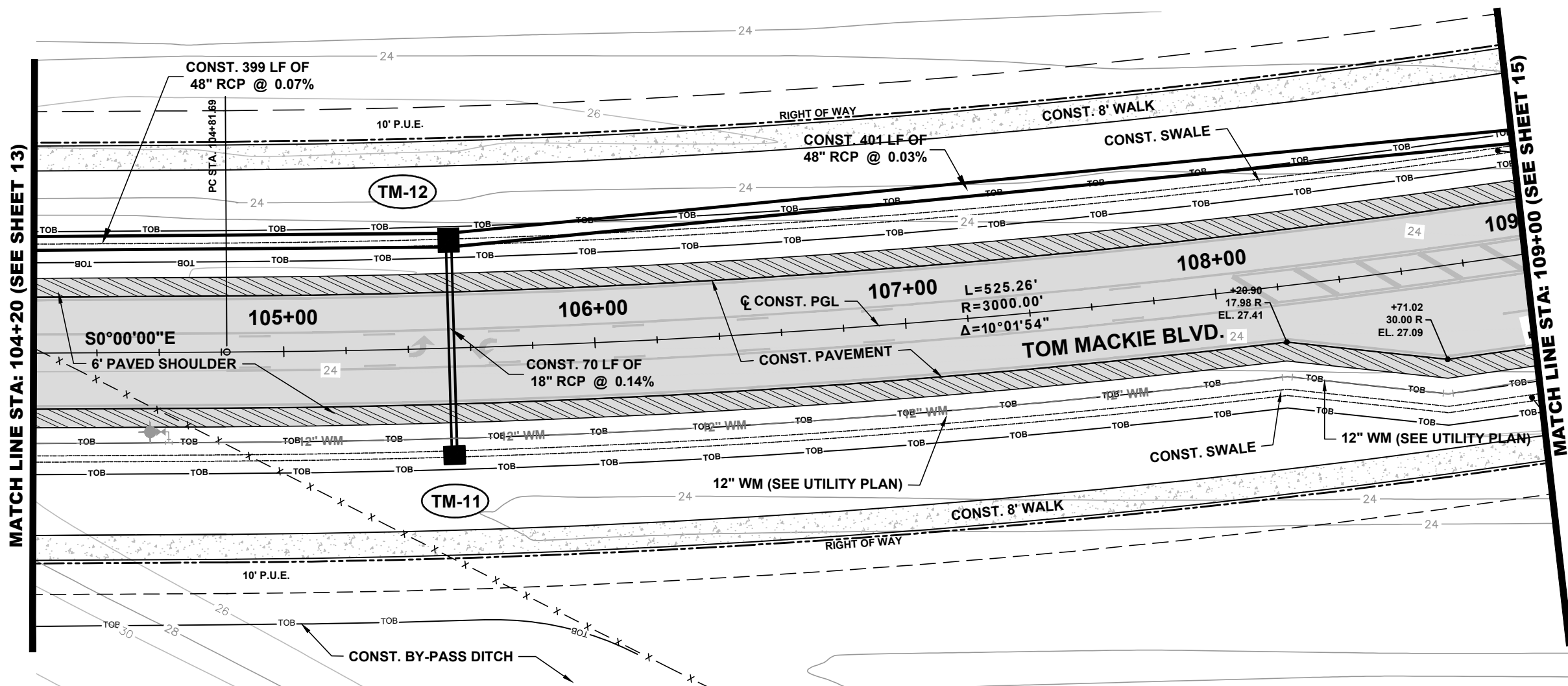

LEGEND:

---	EXISTING ROW	---	WM
---	PROPOSED WATER MAIN	---	RAW
---	FUTURE RAW WATER MAIN	---	FM
---	PROPOSED FORCE MAIN	---	
---	PROPOSED PUBLIC UTILITY EASEMENT	---	
---	PROPOSED 6" HPPP (HIGH-PERFORMANCE POLYPROPYLENE EDGE DRAIN)	---	
---	PROPOSED DRAINAGE PIPE	---	
[Pattern]	4" THICK CONC.	[Pattern]	6" THICK CONC.
[Pattern]		[Pattern]	DETECTABLE WARNING MAT

301 NW Flagler Ave.
Stuart, Florida 34994
Phone: (772) 892-4344
Fax: (772) 892-4341

CAPTEC
Engineering, Inc.
Civil Engineering Professionals

Engineering Business
No. EB-007857

DATE: 8-24-22

DRAWN BY:	MDB
DESIGNED BY:	MDB
CHECKED BY:	###
PROJECT NO.:	2032
HORIZ. SCALE:	1" = 40'
VERT. SCALE:	1" = 10'

CADD FILE:

NO.	DATE	BY	REVISIONS
1	05-14-24	MDB	BID SET

SCALE VERIFICATION

0 0.5 1

SOLID BAR IS EQUAL TO HALF AN INCH ON DRAWING. DIMENSIONS ADJUST ALL SCALED ACCORDINGLY.

TOM MACKIE BLVD. EXTENSION
CITY OF PORT ST. LUCIE, FLORIDA

PLAN AND PROFILE

Joseph W. Capra
301 N.W. Flagler Ave.
Stuart, Florida 34994
P.E. No. 37638

Printed Date:

JOB No.: 2032
SHEET 14 OF 34

PSLUSD # 11-900-23

P:\2000\2032 - PSL Hegener Drive Phase 3\DWG\2032-PLANS.dwg, 5/17/2024 11:32:20 AM

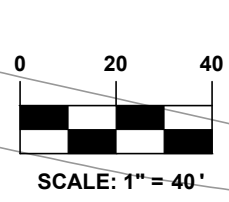
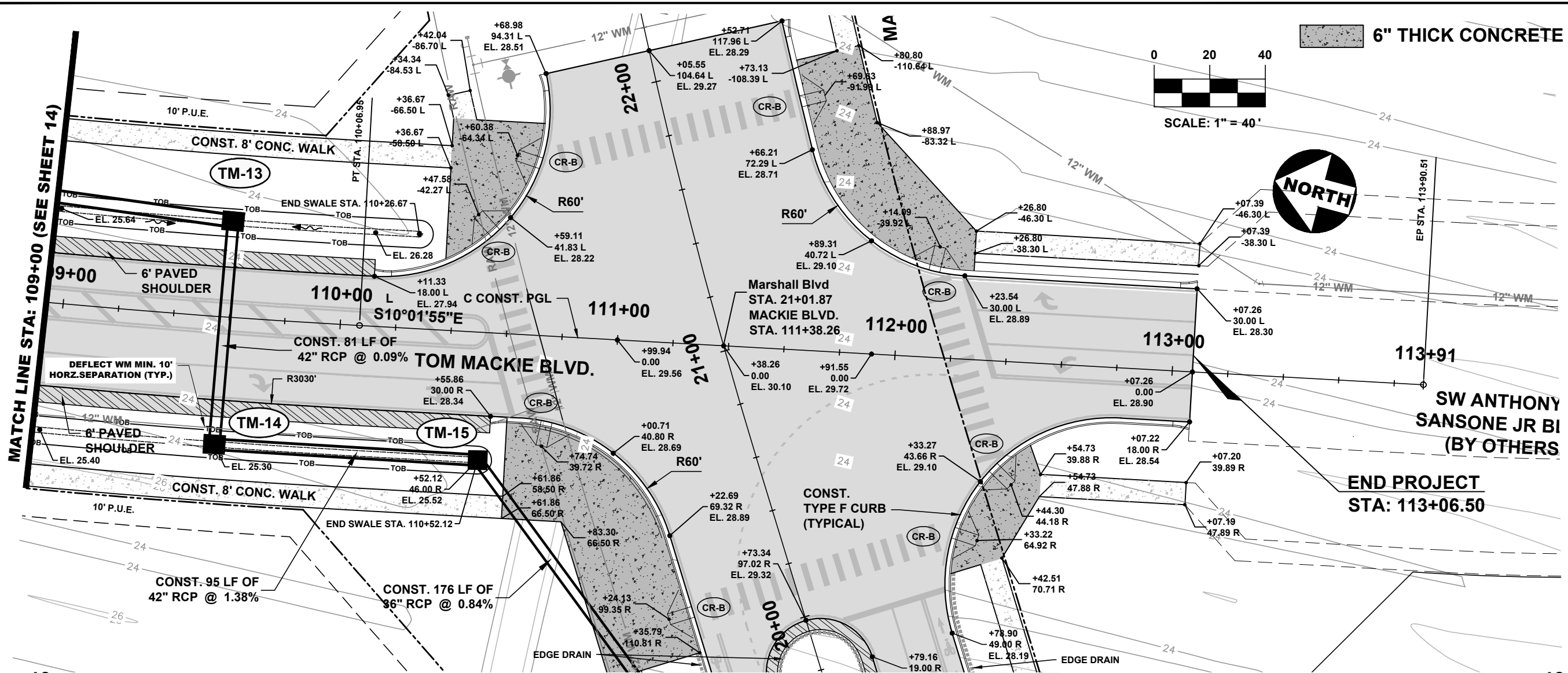

6" THICK CONCRETE

MATCH LINE STA: 109+00 (SEE SHEET 14)

END PROJECT STA: 113+06.50

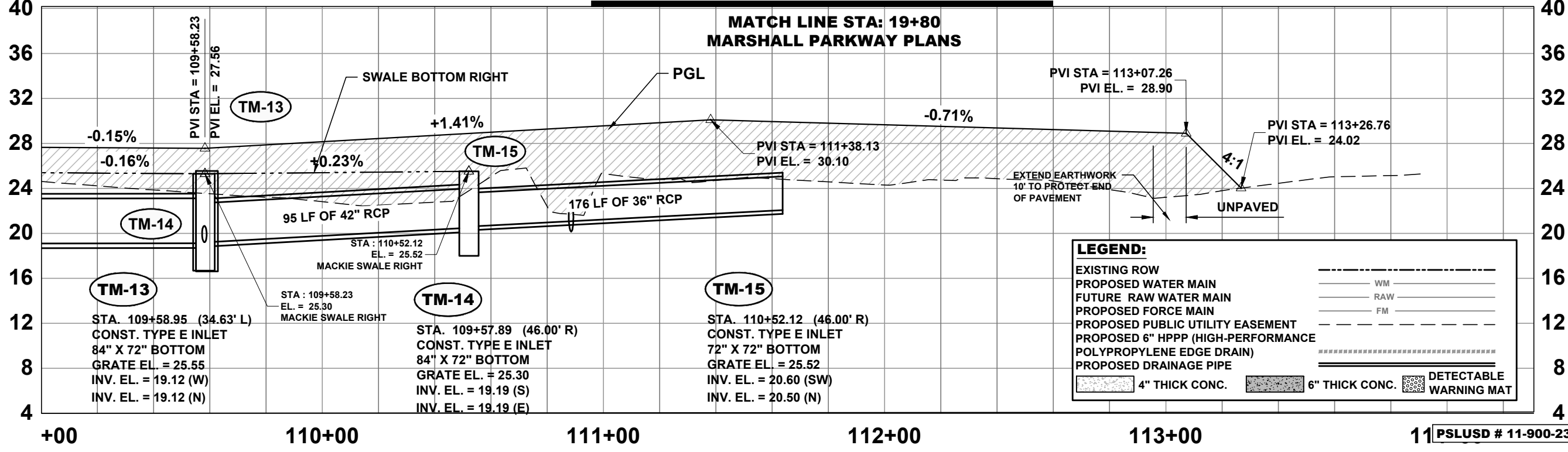

LEGEND:

EXISTING ROW	---
PROPOSED WATER MAIN	---
FUTURE RAW WATER MAIN	---
PROPOSED FORCE MAIN	---
PROPOSED PUBLIC UTILITY EASEMENT	---
PROPOSED 6" HPPP (HIGH-PERFORMANCE POLYPROPYLENE EDGE DRAIN)	---
PROPOSED DRAINAGE PIPE	---
4" THICK CONC.	[Pattern]
6" THICK CONC.	[Pattern]
DETECTABLE WARNING MAT	[Pattern]

301 NW Flagler Ave.
Stuart, Florida 34994
Phone: (772) 892-4344
Fax: (772) 892-4341

Engineering Business
No. EB-007857
Civil Engineering Professionals

DATE: 8-24-22

DRAWN BY:	MDB
DESIGNED BY:	MDB
CHECKED BY:	###
PROJECT NO.:	2032
HORIZ. SCALE:	1" = 40'
VERT. SCALE:	1" = 10'

CADD FILE

NO.	DATE	BY	REVISIONS
1	05-14-24	MDB	BID SET

SCALE VERIFICATION

0 0.5 1 1.5

SOLID BAR IS EQUAL TO HALF AN INCH ON DRAWING. ADJUST ALL SCALED DIMENSIONS ACCORDINGLY.

TOM MACKIE BLVD. EXTENSION
CITY OF PORT ST. LUCIE, FLORIDA

PLAN AND PROFILE

Joseph W. Capra
301 N.W. Flagler Ave.
Stuart, Florida 34994
P.E. No. 37638

Printed Date:

JOB No.: 2032
SHEET 15 OF 34

PSL # P24-010

P:\2000\2032 - PSL Hegener Drive Phase 3\DWG\2032 SECTIONS MACKIE.dwg, 5/17/2024 11:32:39 AM

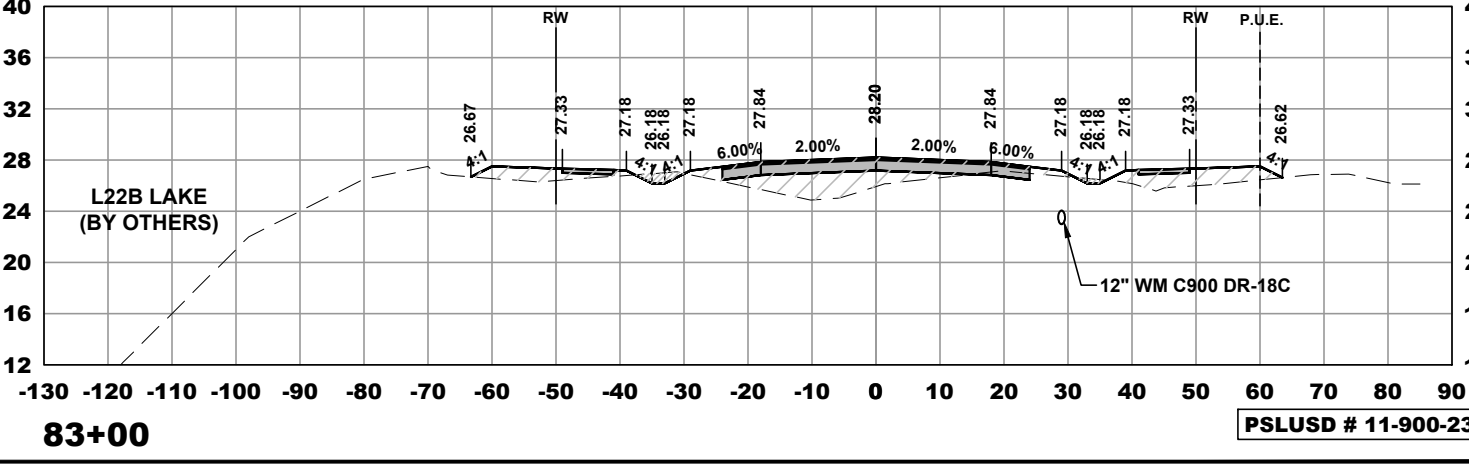
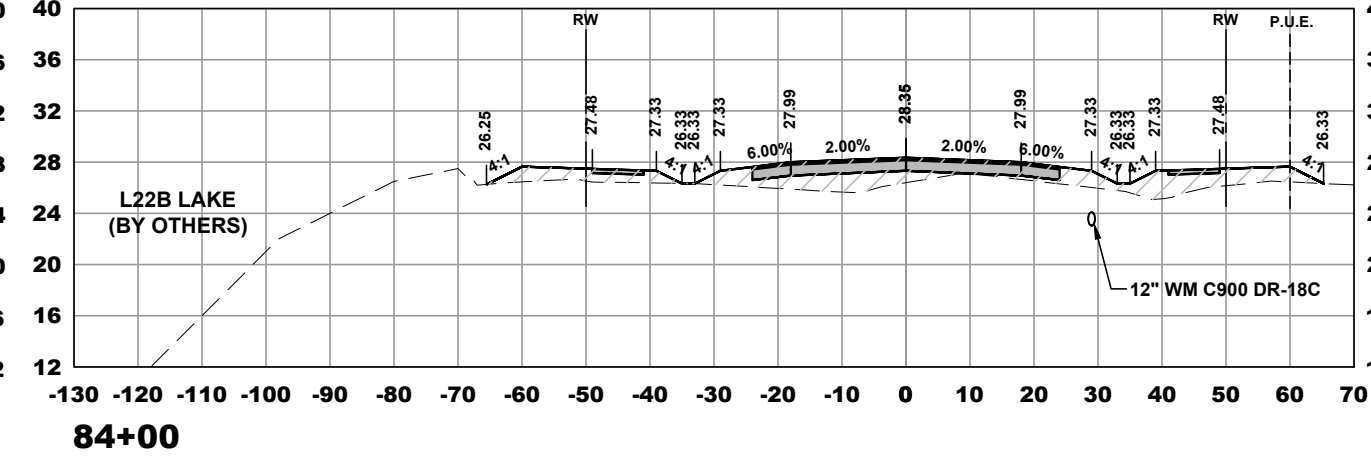
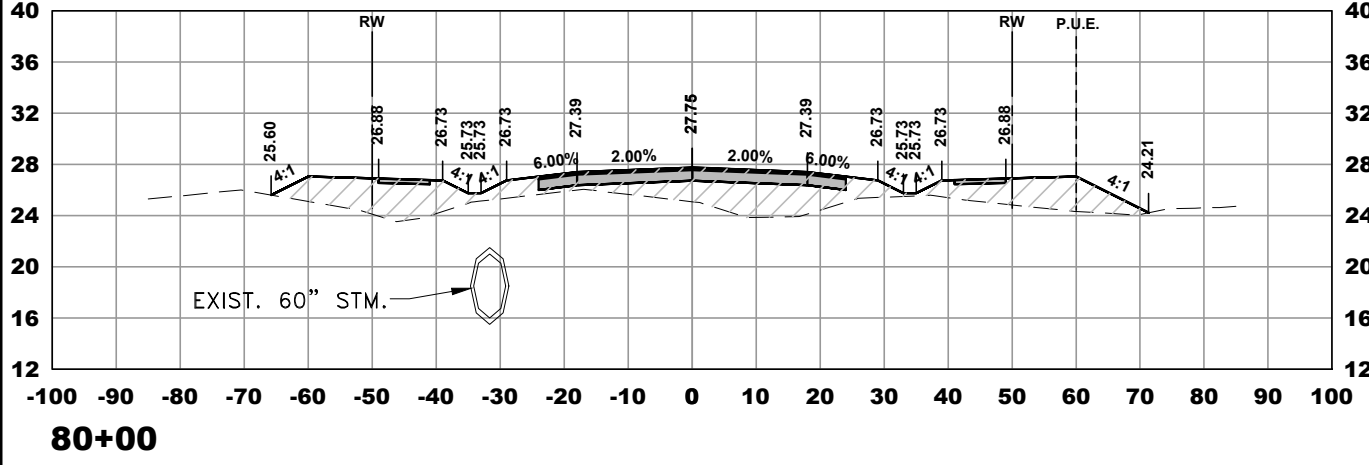
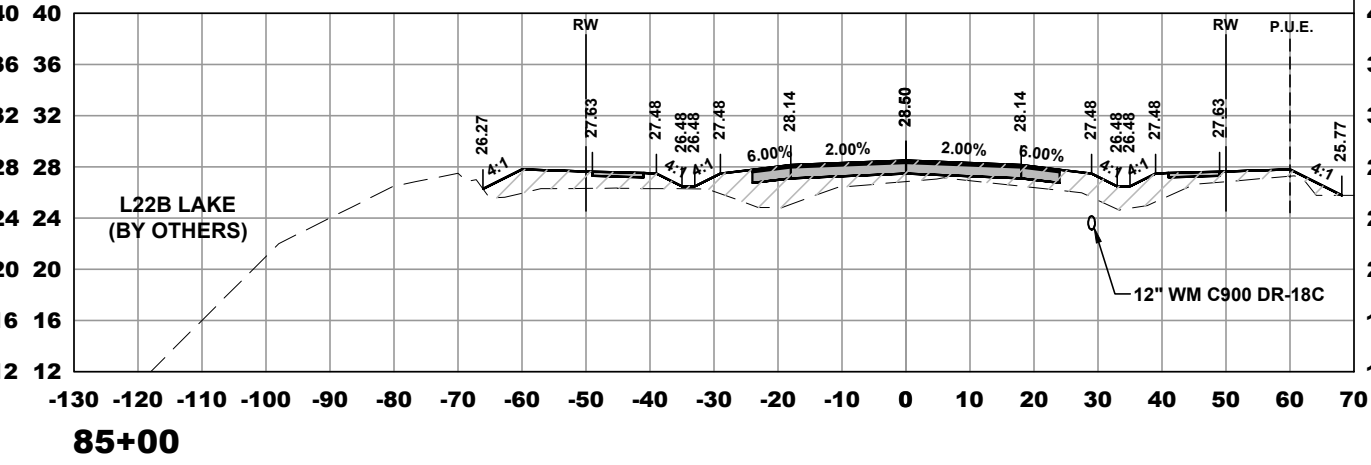
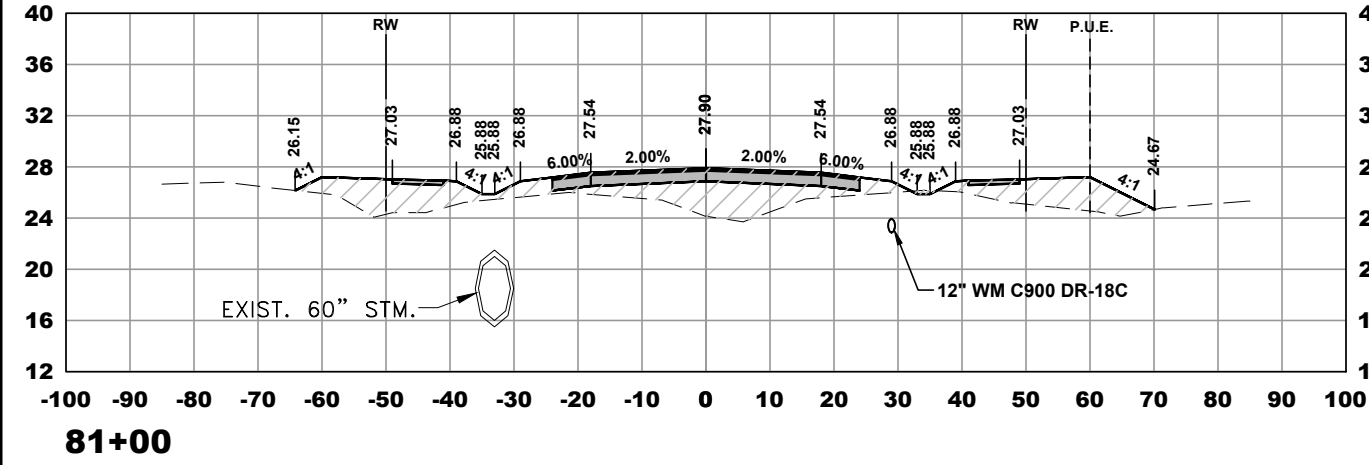
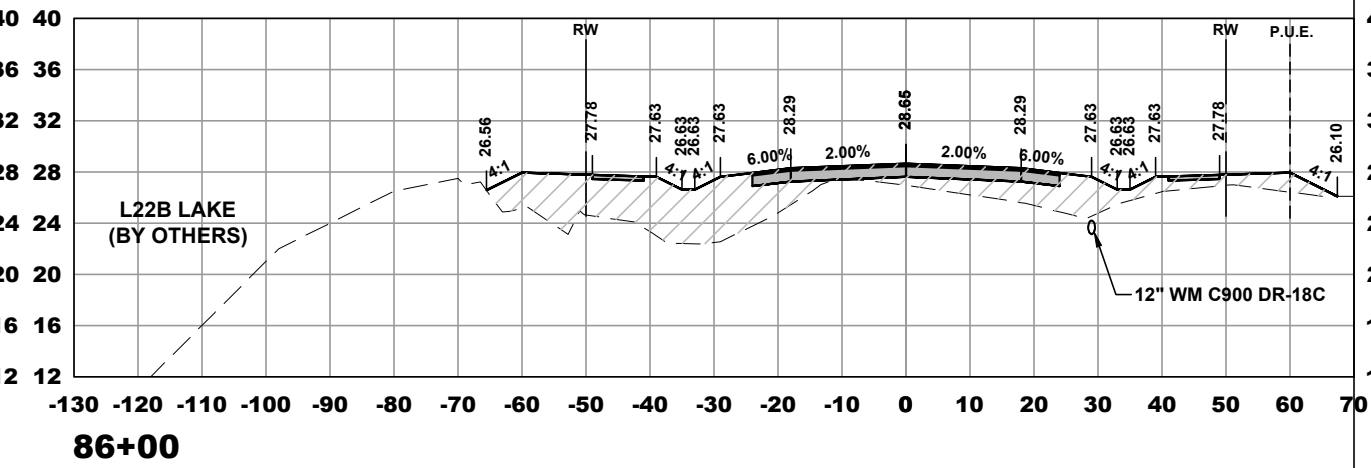
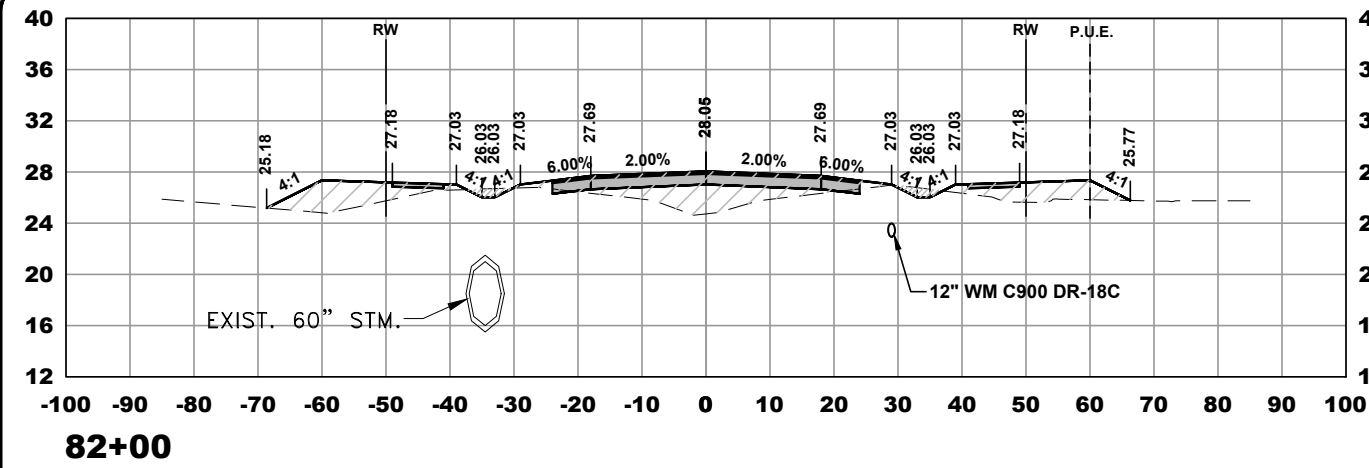

301 N.W. Flagler Ave.
Stuart, Florida 34994
Phone: (772) 892-4344
Fax: (772) 892-4341

Engineering Business
No. EB-007857
Civil Engineering Professionals

DATE: 8-24-22
DRAWN BY: MDB
DESIGNED BY: MDB
CHECKED BY: JWC
PROJECT NO.: 2032
HORZ. SCALE: 1" = 30'
VERT. SCALE: 1" = 15'
CADD FILE:

NO.	DATE	BY	REVISIONS
1	05-14-24	MDB	BID SET

SCALE VERIFICATION
0 0.5
SOLID BAR IS EQUAL TO HALF AN INCH ON ADJUST ALL SCALED DIMENSIONS ACCORDINGLY

TOM MACKIE BLVD. EXTENSION
CITY OF PORT ST. LUCIE, FLORIDA
CROSS SECTIONS

Joseph W. Capra
301 N.W. Flagler Ave.
Stuart, Florida 34994
P.E. No. 37638

Printed Date:
JOB No.: 2032
SHEET
16 OF **34**
PSLUSD # 11-900-23

P:\2000\2032 - PSL Hegener Drive Phase 3\Drawings\2032 SECTIONS\MACKIE.dwg, 5/17/2024 11:32:47 AM

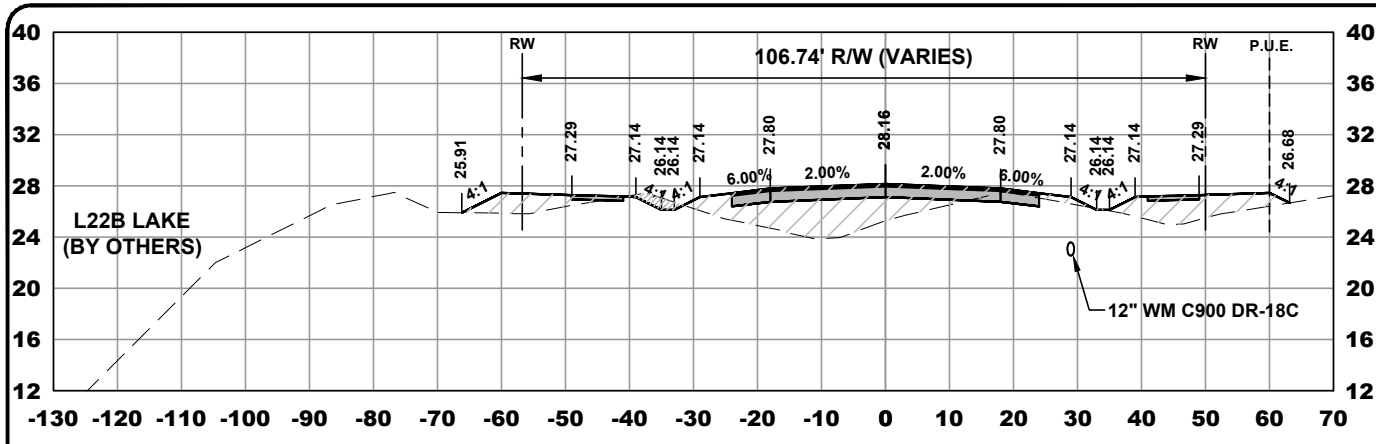

90+00

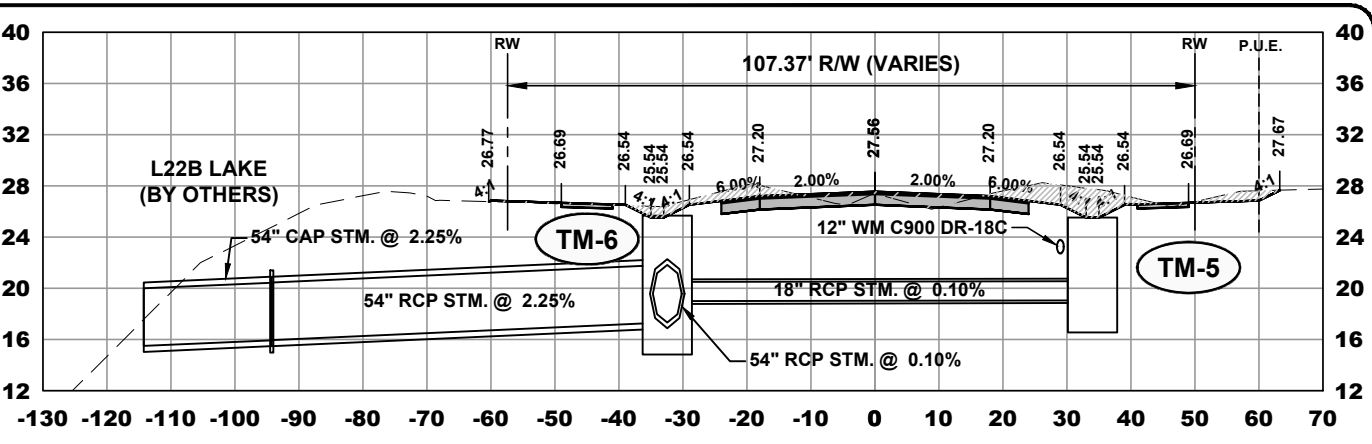

93+90.63

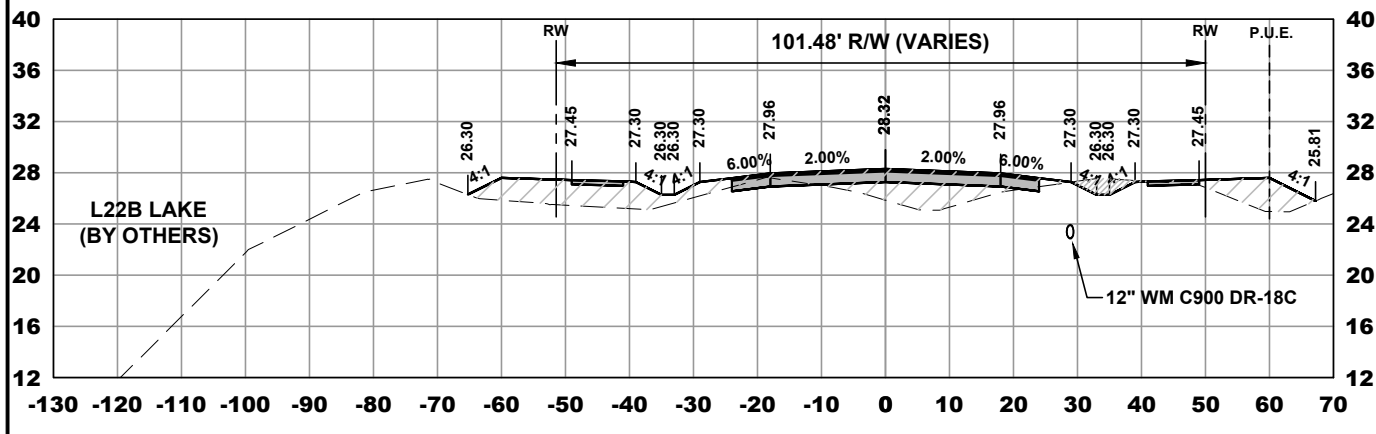

89+00

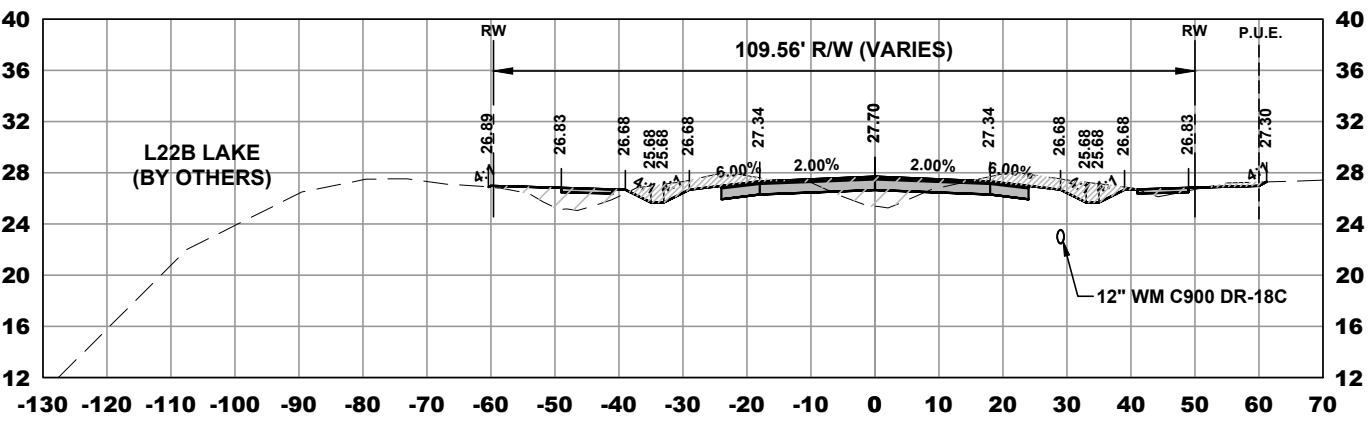

93+00

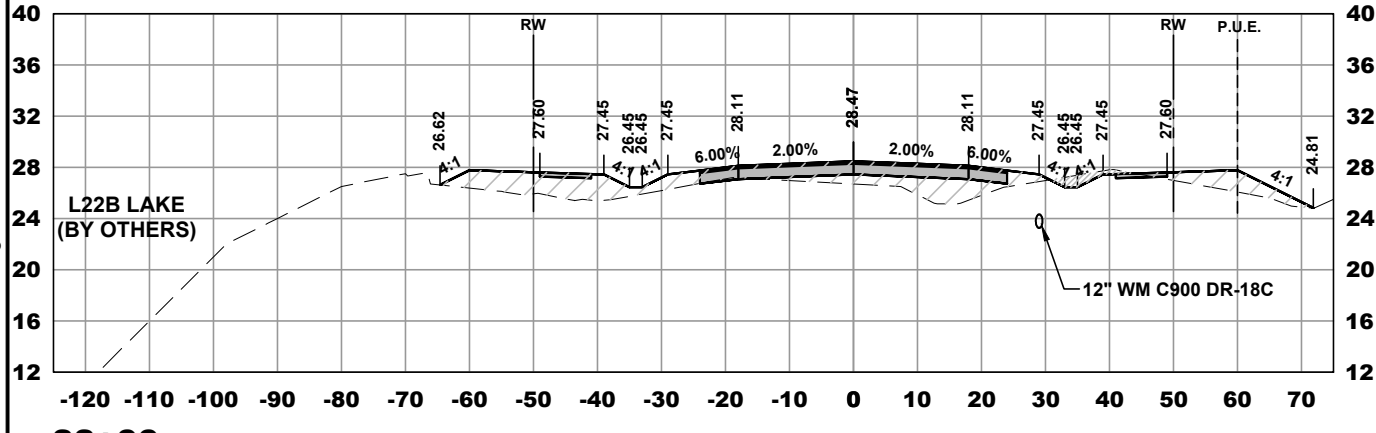

88+00

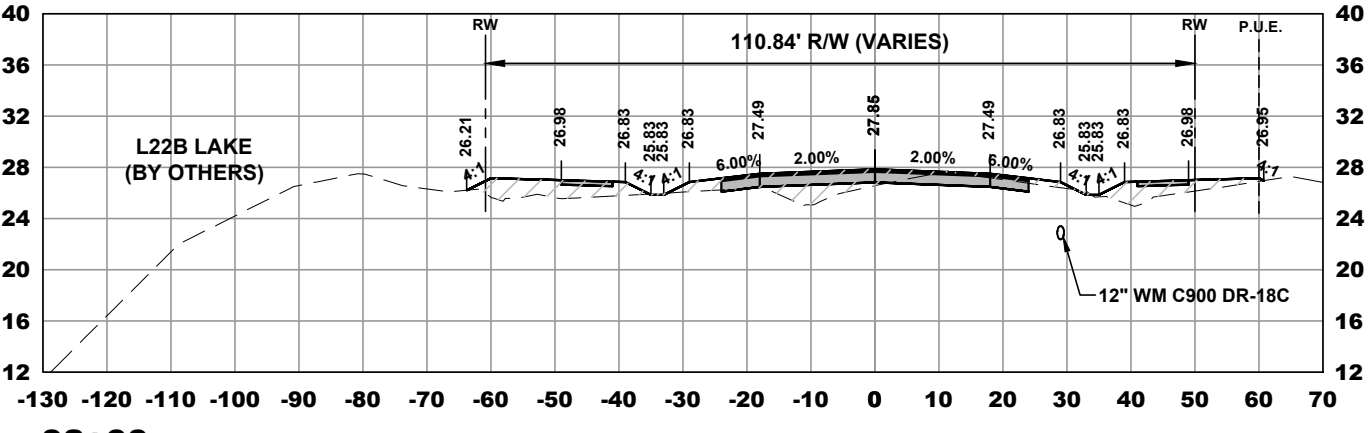

92+00

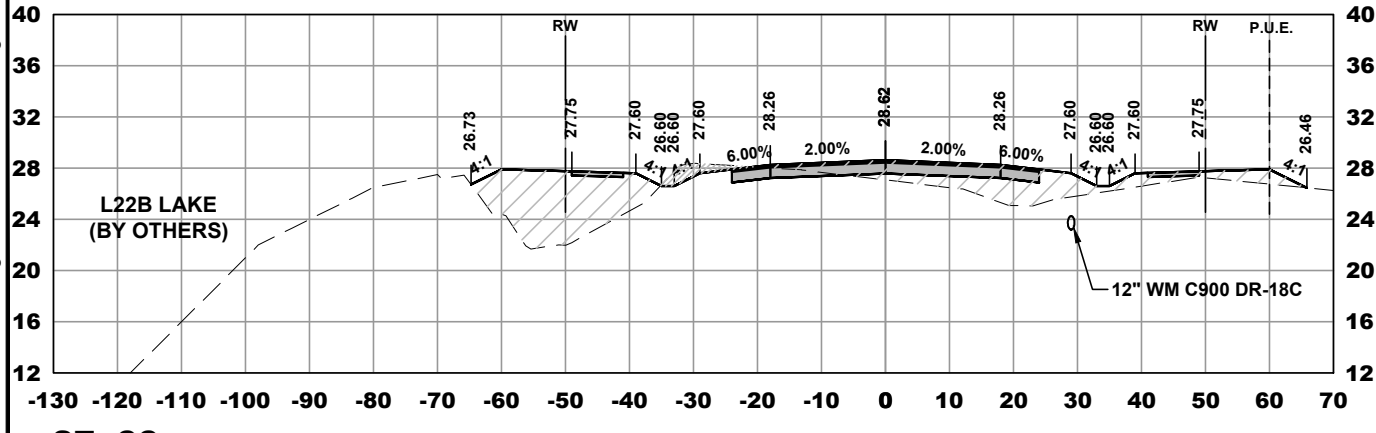

87+00

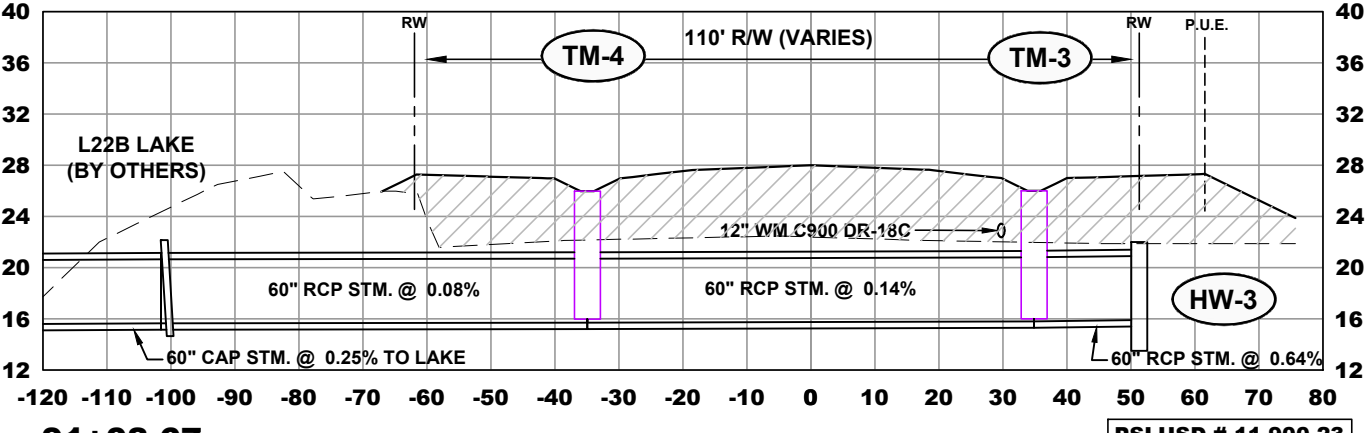

91+08.67

301 N.W. Flagler Ave.
Stuart, Florida 34994
Phone: (772) 892-4344
Fax: (772) 892-4341

CAPTEC
Engineering, Inc.
Civil Engineering Professionals

DATE: 8-24-22

DRAWN BY:	MDB
DESIGNED BY:	MDB
CHECKED BY:	JWC
PROJECT NO.:	2032
HORIZ. SCALE:	1" = 30'
VERT. SCALE:	1" = 15'
CADD FILE:	

NO.	DATE	BY	REVISIONS
1	05-14-24	MDB	BID SET

SCALE VERIFICATION

0 0.5 1

SOLID BAR IS EQUAL TO HALF AN INCH ON DRAWING. ADJUST ALL SCALED DIMENSIONS ACCORDINGLY.

TOM MACKIE BLVD. EXTENSION
CITY OF PORT ST. LUCIE, FLORIDA

CROSS SECTIONS

Joseph W. Capra
301 N.W. Flagler Ave.
Stuart, Florida 34994
P.E. No. 37638

Printed Date:

JOB No.: 2032
SHEET 17 OF 34

PSLUSD # 11-900-23

P:\2000\2032 - PSL Hegener Drive Phase 3\Draw\2032 SECTIONS MACKIE.dwg, 5/17/2024 11:32:52 AM

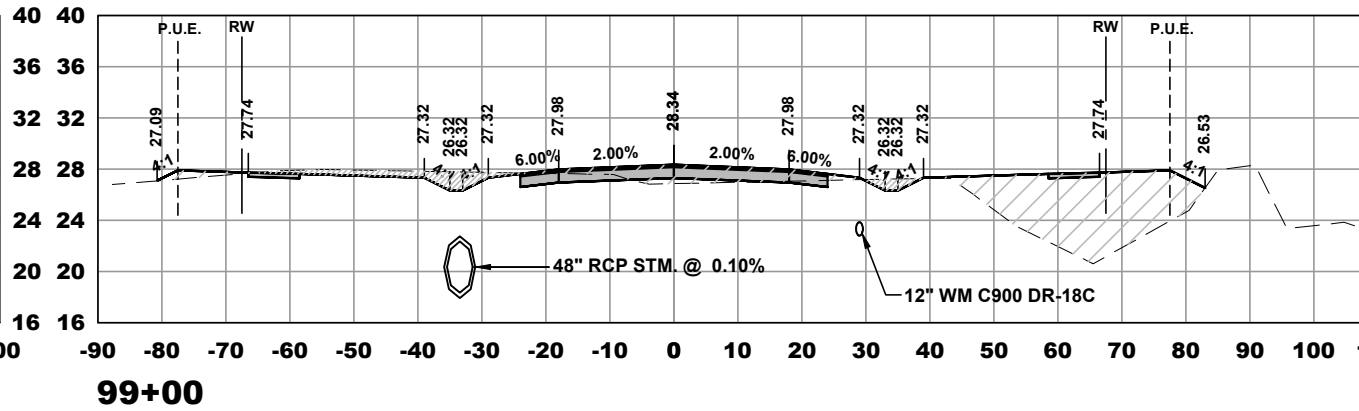
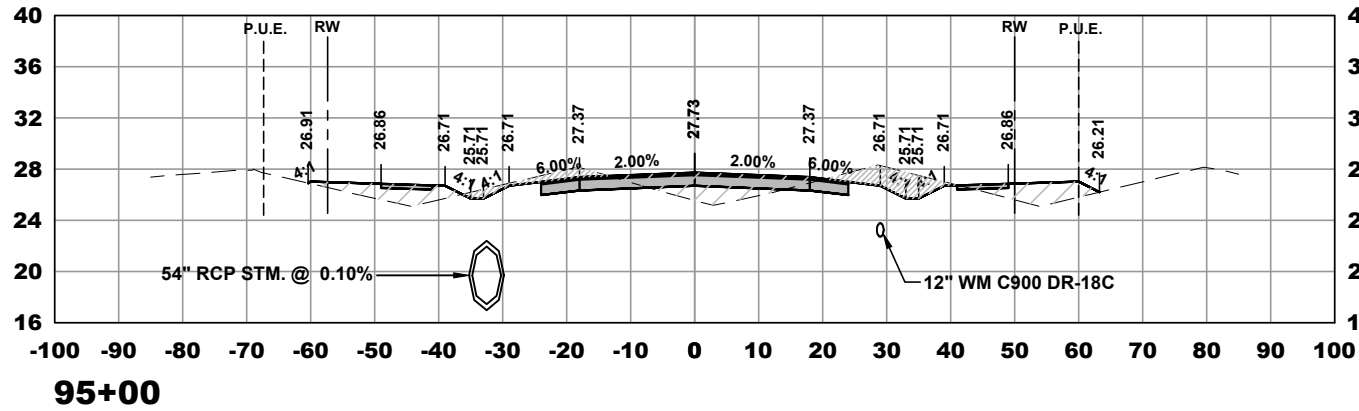
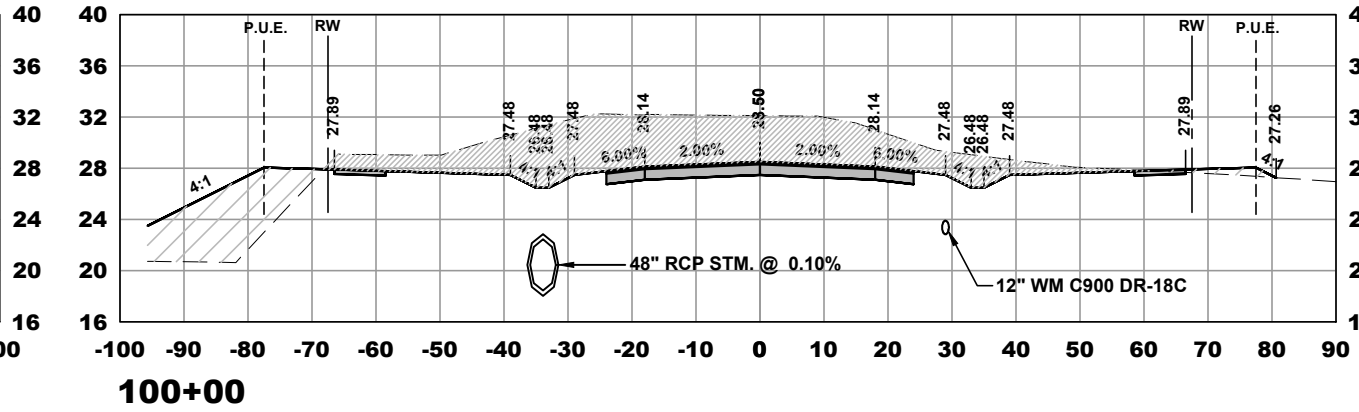
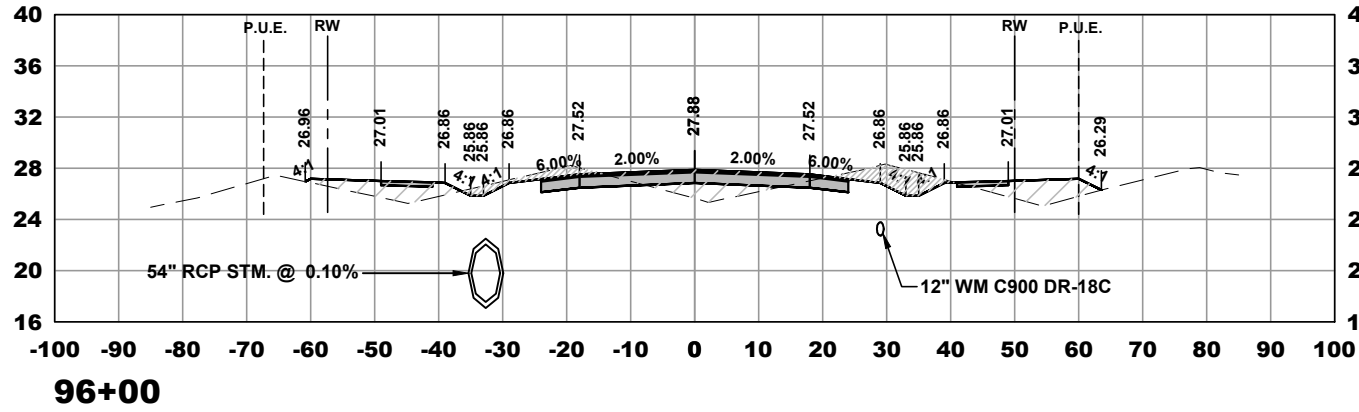
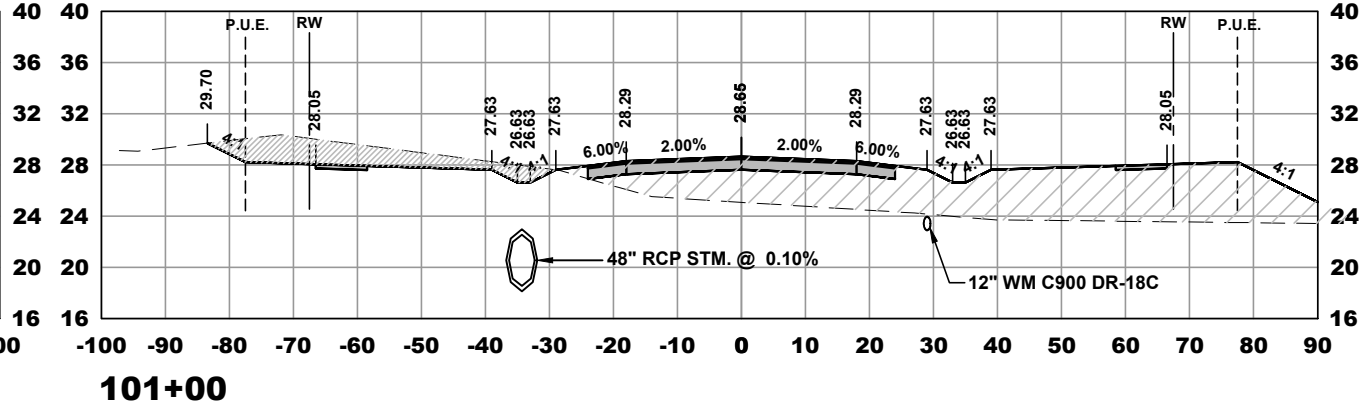
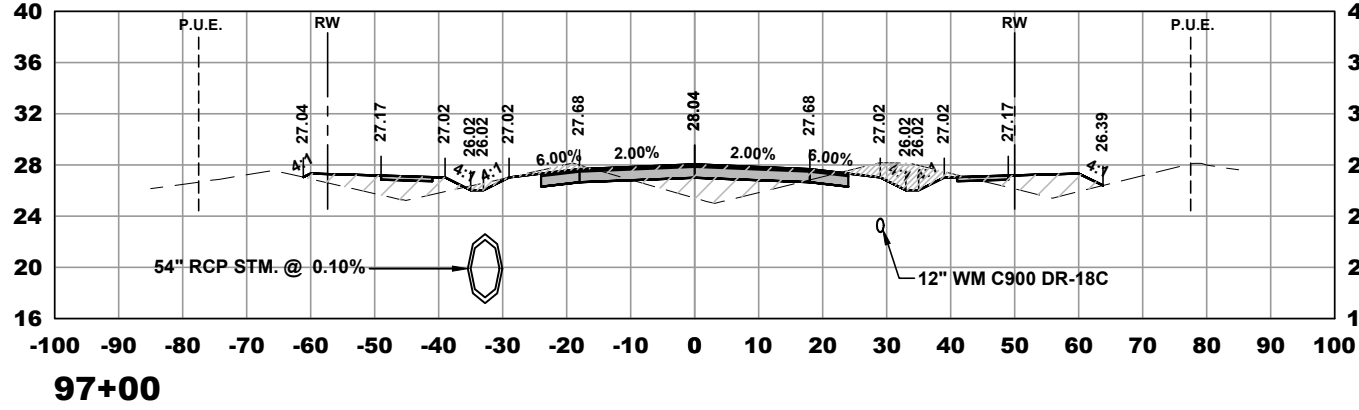
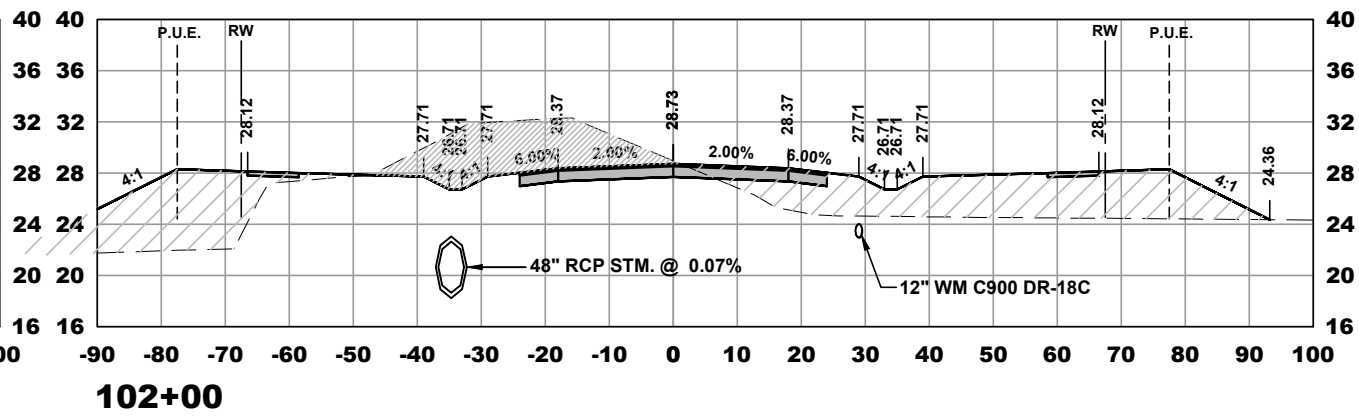
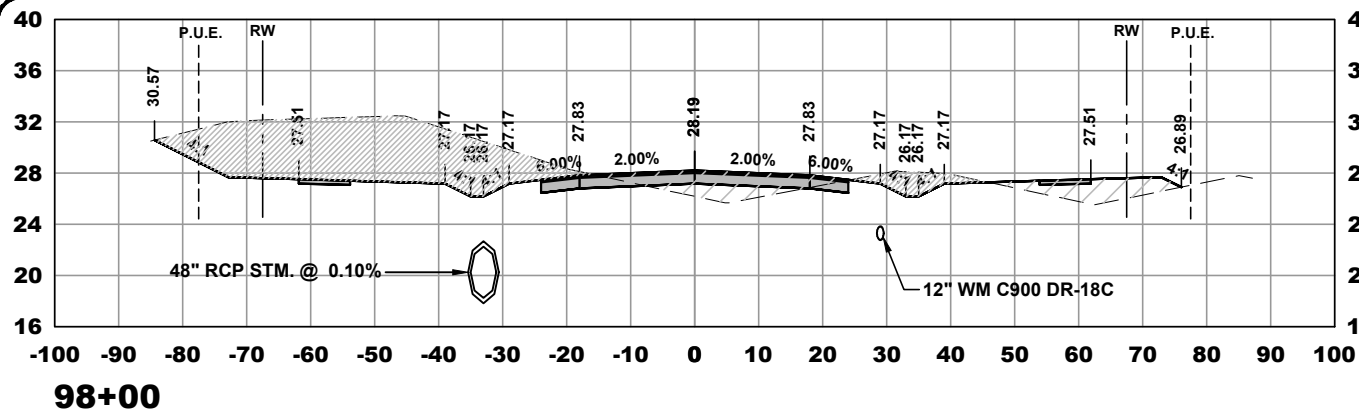

301 N.W. Flagler Ave.
Stuart, Florida 34994
Phone: (772) 892-4344
Fax: (772) 892-4341

CAPTEC
Engineering, Inc.
Civil Engineering Professionals

DATE: 8-24-22
 DRAWN BY: MDB
 DESIGNED BY: JWC
 CHECKED BY: JWC
 PROJECT NO.: 2032
 HORIZ. SCALE: 1" = 30'
 VERT. SCALE: 1" = 15'
 CADD FILE:

NO.	DATE	BY	REVISIONS
1	05-14-24	MDB	BID SET

SCALE VERIFICATION
 0 0.5
 SOLID BAR IS EQUAL TO HALF AN INCH ON ADJUST ALL SCALED DIMENSIONS ACCORDINGLY

TOM MACKIE BLVD. EXTENSION
 CITY OF PORT ST. LUCIE, FLORIDA
CROSS SECTIONS

Joseph W. Capra
 301 N.W. Flagler Ave.
 Stuart, Florida 34994
 P.E. No. 37638

Printed Date:
 JOB No.: 2032
 SHEET
18 OF **34**

PSLUSD # 11-900-23

PSL # P24-010

P:\2000\2032 - PSL Hegener Drive Phase 3\DWG\2032 SECTIONS\MACKIE.dwg, 5/17/2024 11:32:57 AM

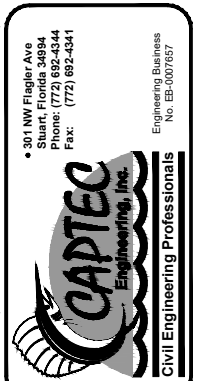
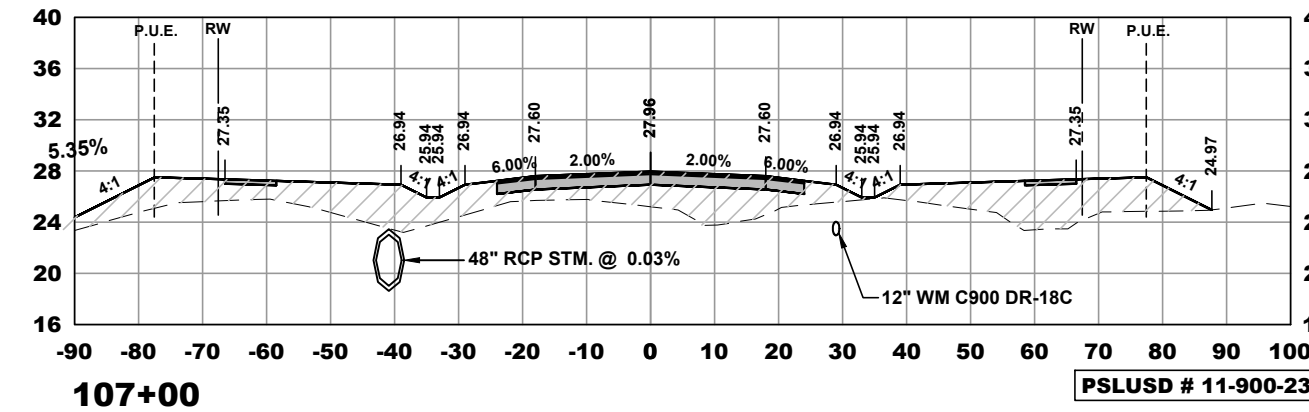
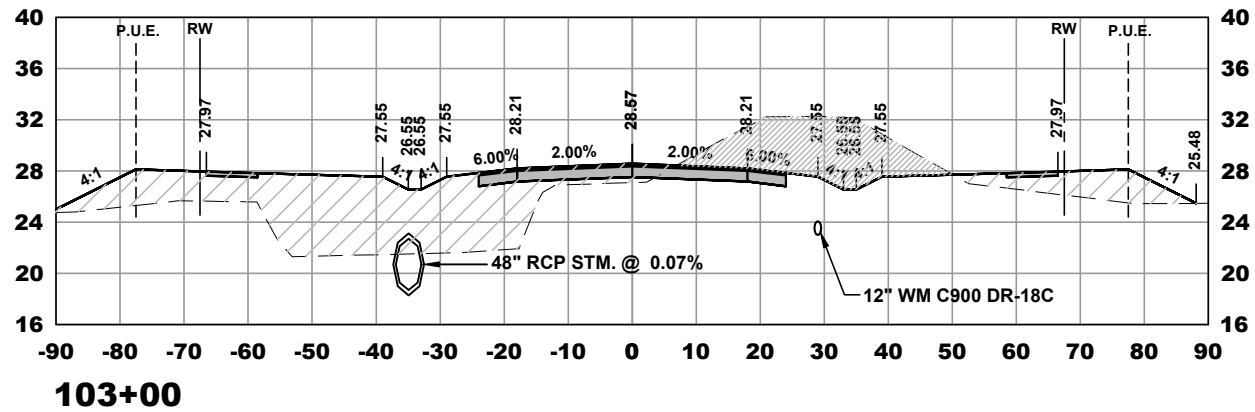
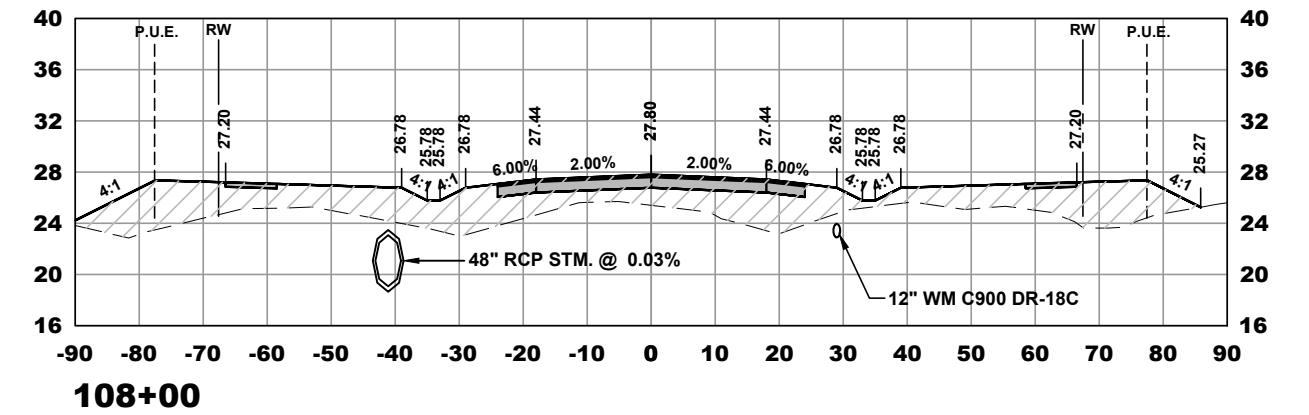
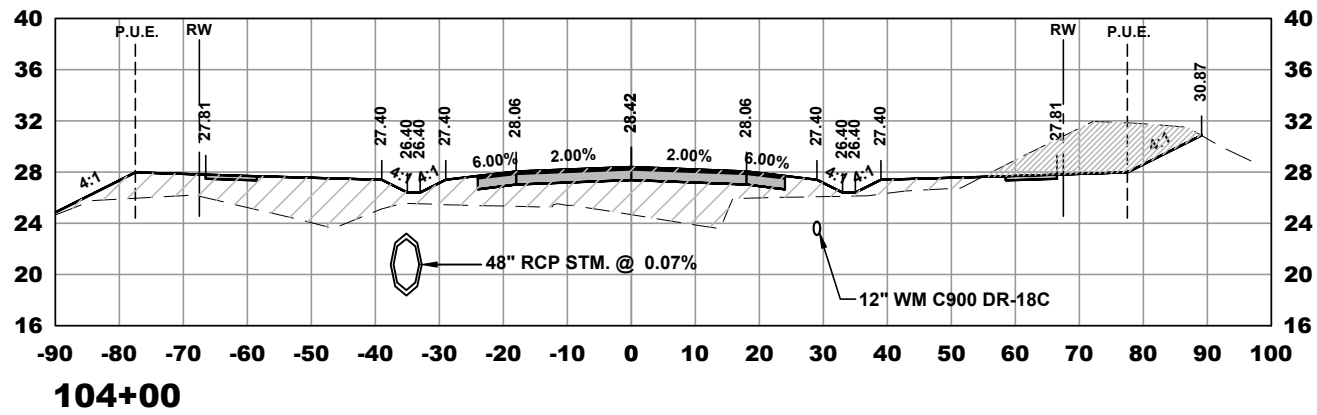
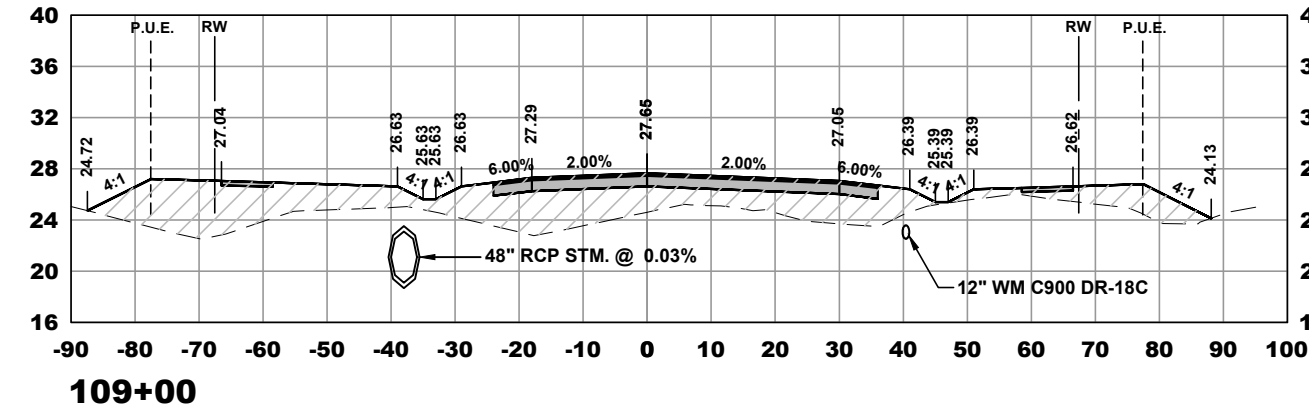
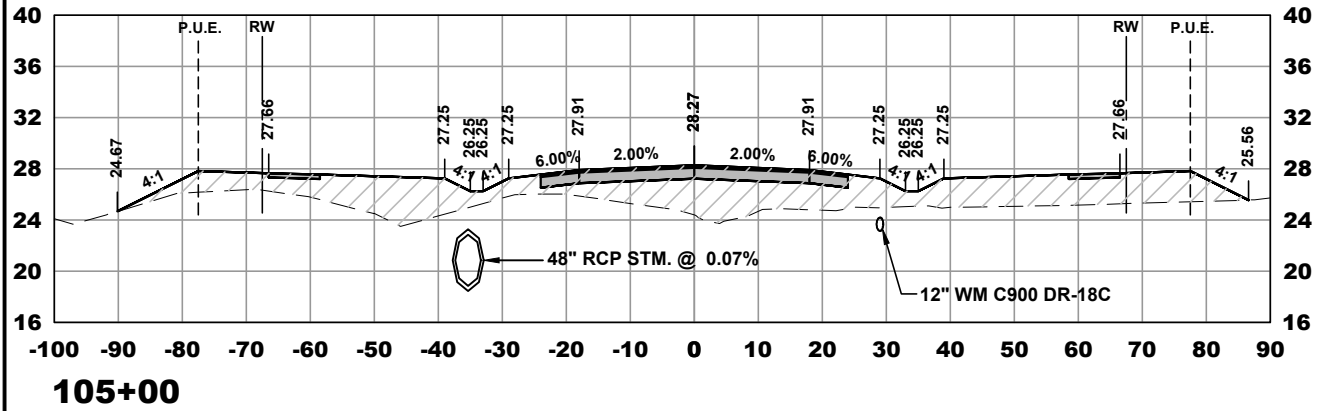
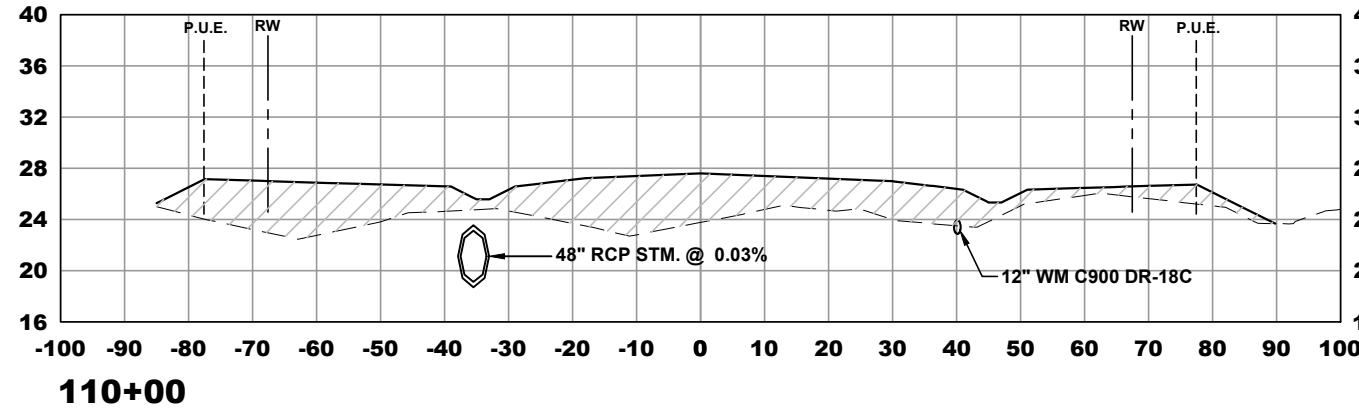
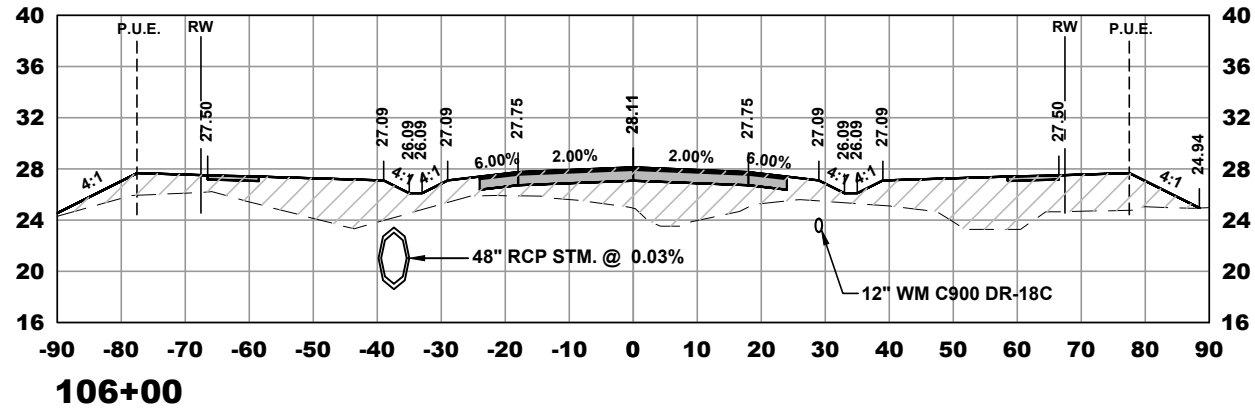

DATE: 8-24-22
 DRAWN BY: MDB
 DESIGNED BY: MDB
 CHECKED BY: JWC
 PROJECT NO.: 2032
 HORZ. SCALE: 1" = 30'
 VERT. SCALE: 1" = 15'
 CAD FILE:

NO.	DATE	BY	REVISIONS
1	05-14-24	MDB	BID SET

SCALE VERIFICATION
 0 0.5
 SOLID BAR IS EQUAL TO HALF AN INCH ON DIMENSIONS
 ADJUST ALL SCALED DIMENSIONS ACCORDINGLY

TOM MACKIE BLVD. EXTENSION
 CITY OF PORT ST. LUCIE, FLORIDA
CROSS SECTIONS

Joseph W. Capra
 301 N.W. Flagler Ave.
 Stuart, Florida 34994
 P.E. No. 37638

Printed Date:
 JOB No.: 2032
 SHEET 19 OF 34
 PSLUSD # 11-900-23

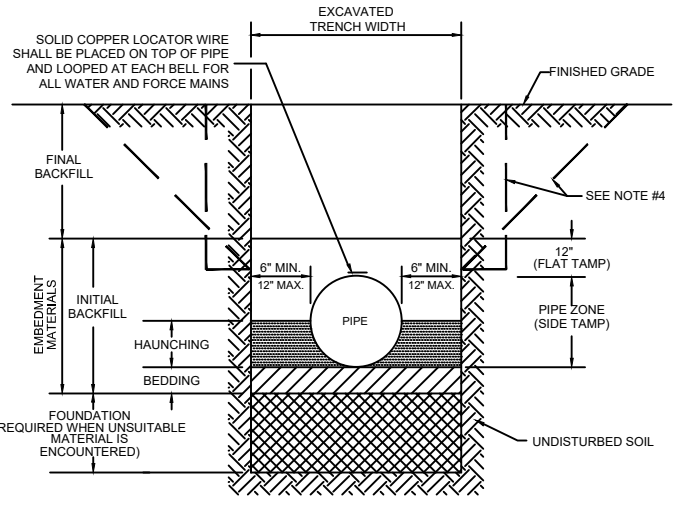

- NOTES:**
- FOR TRENCHES REQUIRING SHEETING, SHORING, STAY BRACING, TRENCH JACKS OR TRENCH BOX, DIMENSIONS SHALL BE TAKEN FROM THE INSIDE FACE OF THE SUPPORTS.
 - IF THE MAXIMUM TRENCH WIDTH MUST BE EXCEEDED, THE AREA OUTSIDE OF THE MAXIMUM EMBEDMENT SHALL BE COMPACTED TO FINAL BACKFILL REQUIREMENTS. IF THE PIPE IS INSTALLED IN A COMPACTED EMBANKMENT, THE EMBANKMENT SHALL BE IN PLACE AND COMPACTED TO 12" MIN. COVER BEFORE INSTALLATION OF PIPE.
 - IF BEDDING IS REQUIRED TO BRING TRENCH BOTTOM UP TO GRADE AND PROVIDE UNIFORM AND ADEQUATE LONGITUDINAL SUPPORT UNDER THE PIPE, THEN A MINIMUM COMPACTED DEPTH OF 4 TO 6 INCHES OF SELECT EMBEDMENT MATERIAL IS REQUIRED.
 - THE CONTRACTOR SHALL COMPLY WITH REQUIREMENTS OF THE FLORIDA TRENCH SAFETY ACT.
 - AN APPROVED LOCATOR WIRE SHALL BE USED.
 - EARTHWORK, EXCAVATION, BACKFILL AND COMPACTION SHALL BE IN ACCORDANCE WITH PSLUSD STANDARDS.

MINIMUM CONSTRUCTION STANDARDS FOR CITY OF PORT ST. LUCIE 900 S.E. OGDEN LANE PORT ST. LUCIE, FL 34983 PHONE (772) 873-6400 FAX (772) 873-6433	STANDARD PIPE TRENCH CROSS SECTION	DETAIL: G-04
		DATE: 2015
		SCALE: N.T.S.
		SHEET: 1 OF 1

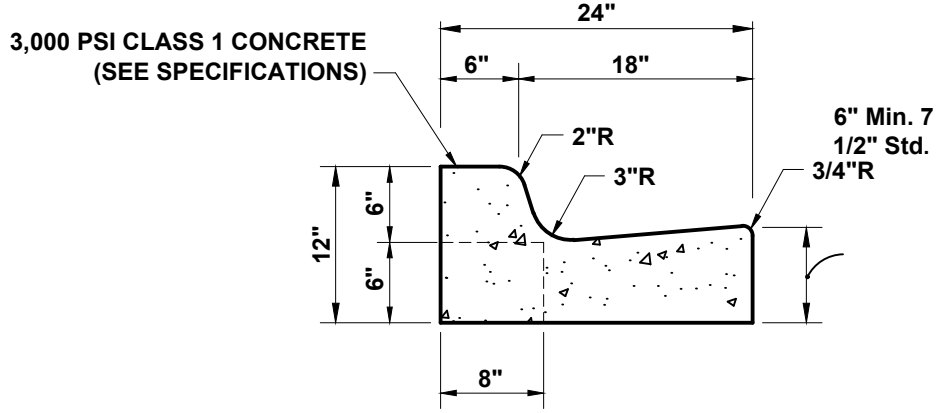

SECTION VIEW
TYPE F CURB

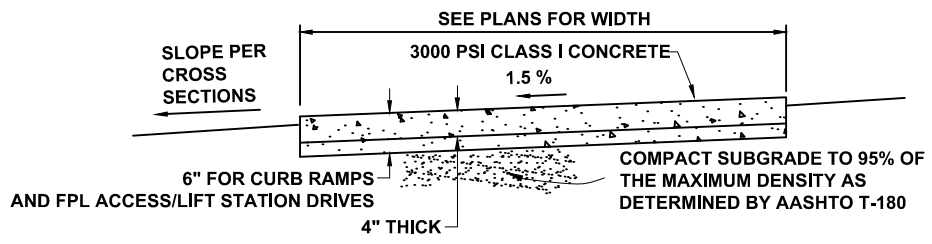

- NOTES:**
- PROVIDE CONTRACTION JOINTS EQUAL TO WIDTH OF 8' SIDEWALK AND 5' CENTER TO CENTER ALL OTHERS.
 - SOD SHALL BE PLACED BELOW EDGE OF SIDEWALK TO ALLOW DRAINAGE.
 - ALL SIDEWALK JOINTS MUST BE TOOLED WITHOUT EXPANSION JOINTS.

TYPICAL SIDEWALK

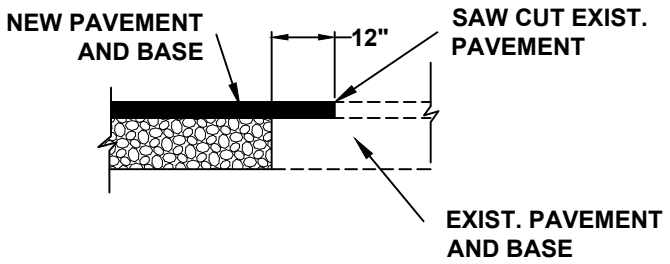

SAW-CUT DETAIL
NTS

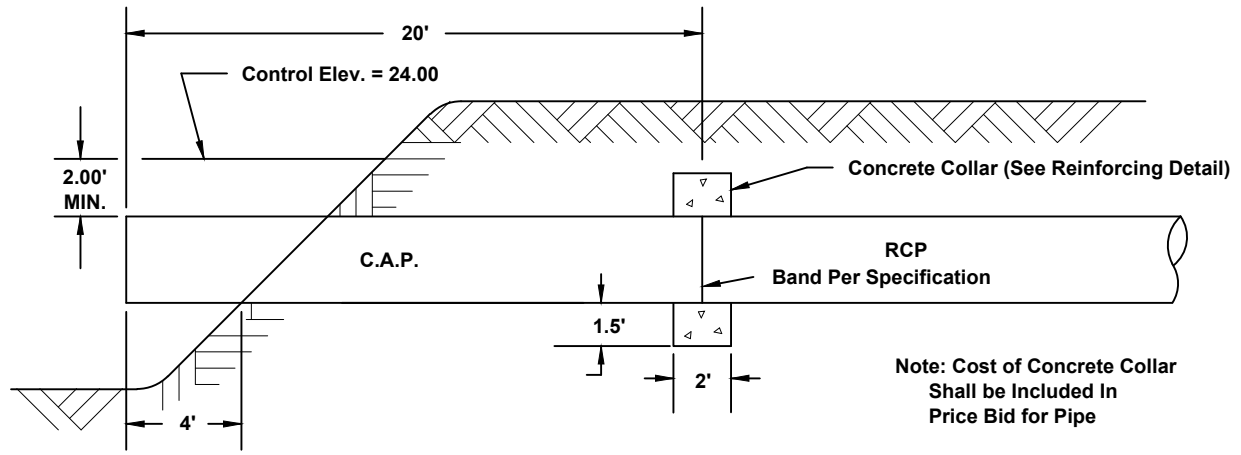

CANTILEVERED END AND CONCRETE COLLAR - D.O.T.
INDEX 430-001 DETAIL

Note: Cost of Concrete Collar Shall be Included in Price Bid for Pipe

301 NW Flagler Ave
 Phone: (772) 892-4344
 Fax: (772) 892-4341

 Engineering Business
 No. EB-007857
 Civil Engineering Professionals

DATE: 8-24-22	DRAWN BY: MDB	DESIGNED BY: MDB	CHECKED BY: JWC	PROJECT No.: 2032	HORIZ. SCALE: NTS	VERT. SCALE: N/A	CADD FILE: 2022 DETAILS
---------------	---------------	------------------	-----------------	-------------------	-------------------	------------------	-------------------------

NO.	DATE	BY	REVISIONS
1	05-14-24	MDB	BID SET

SCALE VERIFICATION	0.5
SOLID BAR IS EQUAL TO HALF AN INCH ON ORIGINAL DRAWING. ALL DIMENSIONS ACCORDINGLY.	

TOM MACKIE BLVD. EXTENSION
 CITY OF PORT ST. LUCIE, FLORIDA
PAVING AND DRAINAGE DETAILS

Joseph W. Capra
 301 N.W. Flagler Ave.
 Stuart, Florida 34994
 P.E. No. 37638

Printed Date:

JOB No.: 2032
SHEET 20 OF 34

PSLUSD # 11-900-23

P:\2000\2032 - PSL Hegener Drive Phase 3\DWG\2032 DETAILS.dwg, 5/17/2024 11:33:04 AM

P:\2000\2032 - PSL Hegener Drive Phase 3\DWG\2032-TM-MARKING.dwg, 5/17/2024 11:33:10 AM

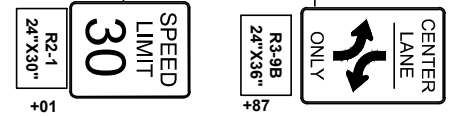
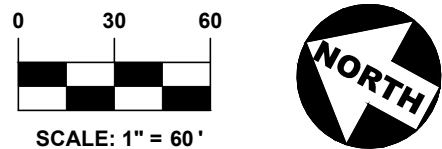
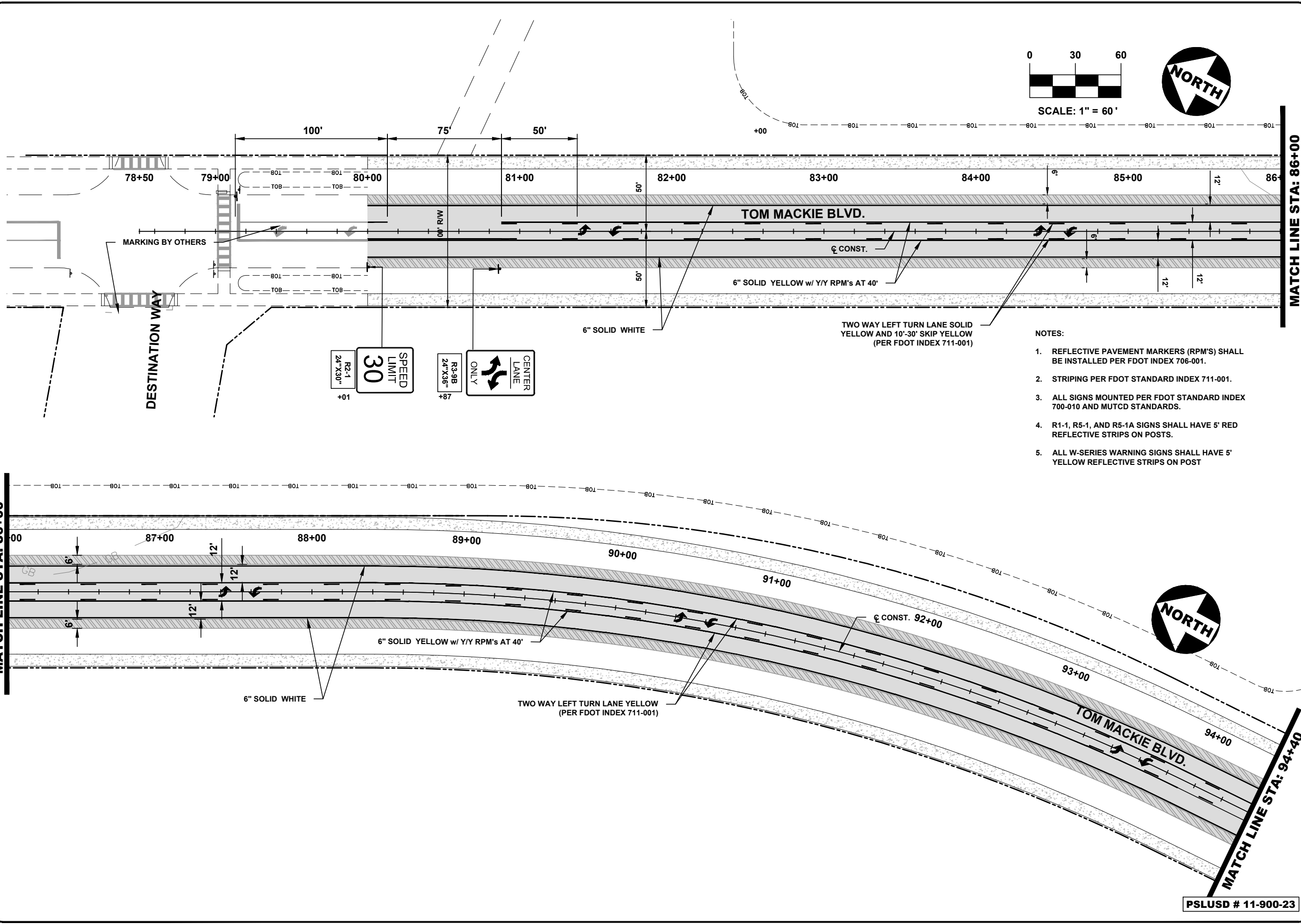

NOTES:

1. REFLECTIVE PAVEMENT MARKERS (RPM'S) SHALL BE INSTALLED PER FDOT INDEX 706-001.
2. STRIPING PER FDOT STANDARD INDEX 711-001.
3. ALL SIGNS MOUNTED PER FDOT STANDARD INDEX 700-010 AND MUTCD STANDARDS.
4. R1-1, R5-1, AND R5-1A SIGNS SHALL HAVE 5' RED REFLECTIVE STRIPS ON POSTS.
5. ALL W-SERIES WARNING SIGNS SHALL HAVE 5' YELLOW REFLECTIVE STRIPS ON POST

301 NW Flagler Ave.
Stuart, Florida 34994
Phone: (772) 892-4344
Fax: (772) 892-4341

CAPTEC
Engineering, Inc.
Civil Engineering Professionals

DATE: 8-24-22

DRAWN BY:	MDB
DESIGNED BY:	MDB
CHECKED BY:	###
PROJECT NO.:	2032
HORIZ. SCALE:	1" = 60'
VERT. SCALE:	1" = 60'
CADD FILE:	

NO.	DATE	BY	REVISIONS
1	08-14-24	MDB	BID SET

SCALE VERIFICATION

0 0.5 1

SOLID BAR IS EQUAL TO HALF AN INCH ON DRAWING. ALL DIMENSIONS ADJUST ALL SCALED ACCORDINGLY

TOM MACKIE BLVD. EXTENSION
CITY OF PORT ST. LUCIE, FLORIDA

PAVEMENT MARKING AND SIGNAGE

Joseph W. Capra
301 N.W. Flagler Ave.
Stuart, Florida 34994
P.E. No. 37638

Printed Date:

JOB No.: 2032
SHEET 21 OF 34

PSLUSD # 11-900-23

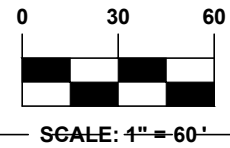
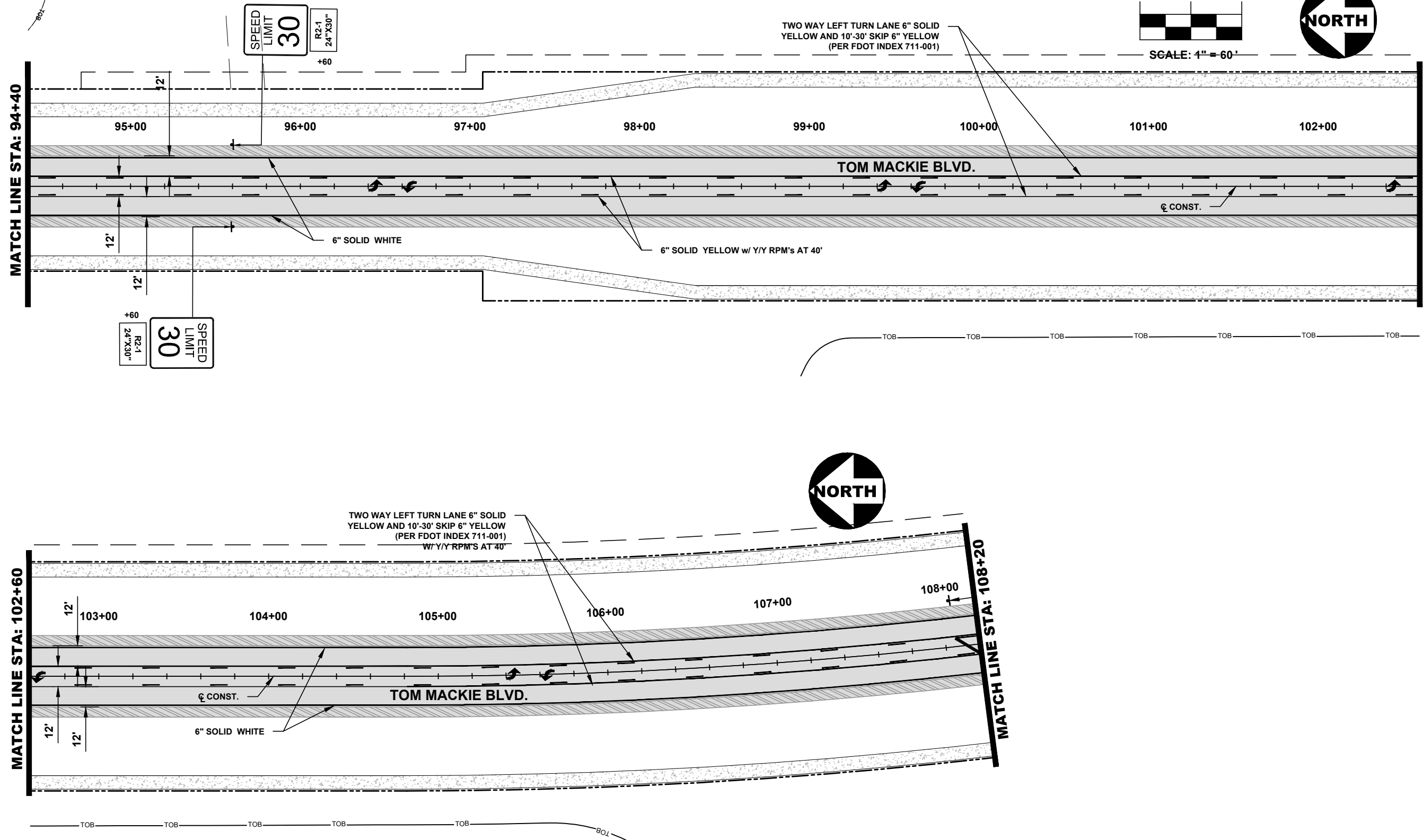

301 NW Flagler Ave.
 Stuart, Florida 34994
 Phone: (772) 892-4344
 Fax: (772) 892-4341

CAPTEC
 Engineering, Inc.
 Civil Engineering Professionals

Engineering Business
 No. EB-007857

DATE: 8-24-22

DRAWN BY:	MDB
DESIGNED BY:	MDB
CHECKED BY:	###
PROJECT No.:	2032
HORIZ. SCALE:	1" = 60'
VERT. SCALE:	
CADD FILE:	

NO.	DATE	BY	BID SET	REVISIONS
1	05-14-24	MDB		

SCALE VERIFICATION

0 0.5

SOLID BAR IS EQUAL TO HALF AN INCH ON ADJUST ALL SCALED DIMENSIONS ACCORDINGLY

TOM MACKIE BLVD. EXTENSION
 CITY OF PORT ST. LUCIE, FLORIDA

PAVEMENT MARKING AND SIGNAGE

Joseph W. Capra
 301 N.W. Flagler Ave.
 Stuart, Florida 34994
 P.E. No. 37638

Printed Date:

JOB No.: 2032
 SHEET 22 OF 34

PSLUSD # 11-900-23

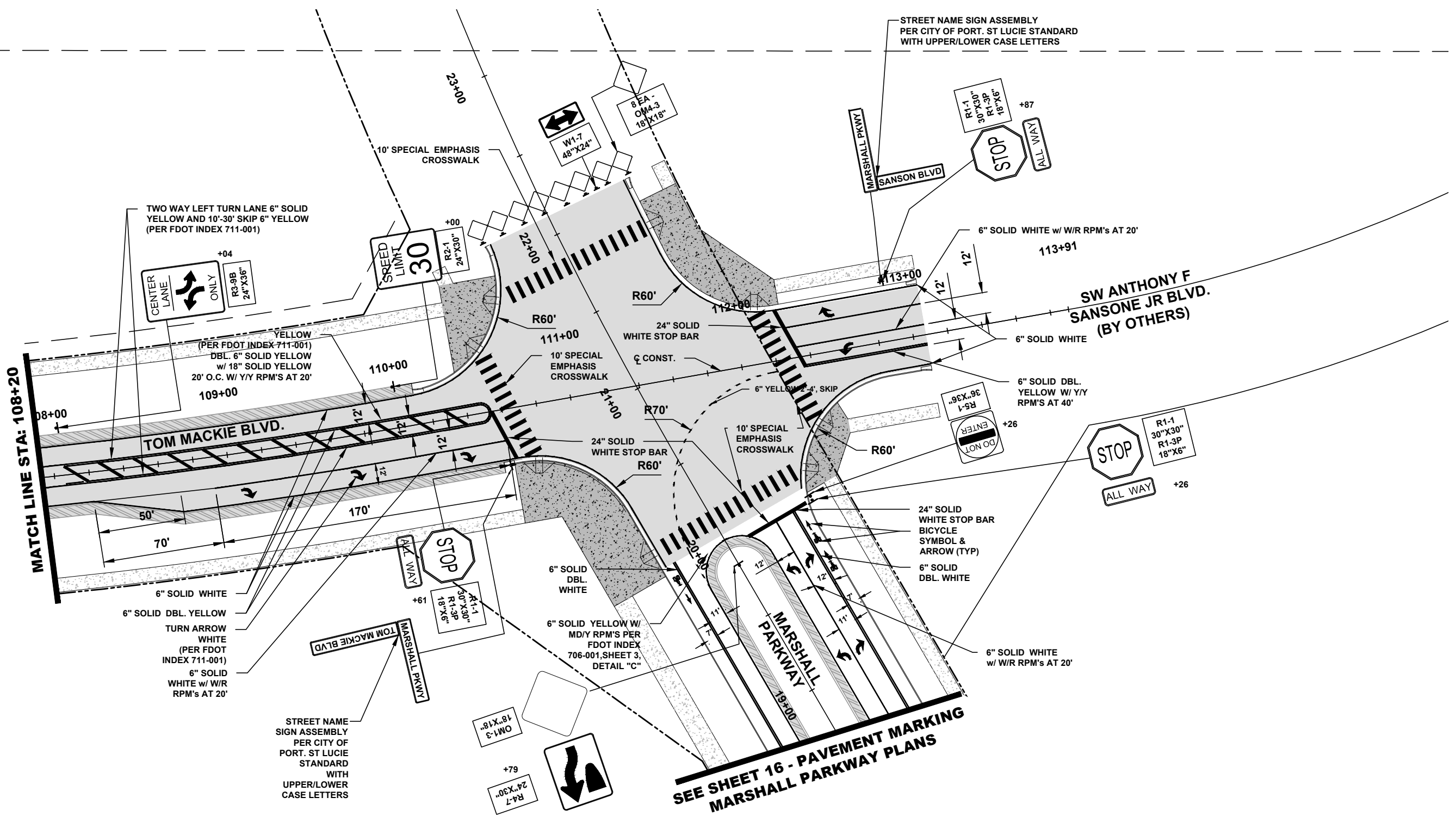
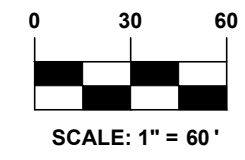

TWO WAY LEFT TURN LANE 6" SOLID YELLOW AND 10'-30" SKIP 6" YELLOW (PER FDOT INDEX 711-001)

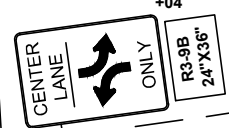

YELLOW (PER FDOT INDEX 711-001) DBL. 6" SOLID YELLOW w/ 18" SOLID YELLOW 20' O.C. W/ Y/Y RPM'S AT 20'

6" SOLID WHITE
6" SOLID DBL. YELLOW TURN ARROW WHITE (PER FDOT INDEX 711-001)
6" SOLID WHITE w/ W/R RPM'S AT 20'

STREET NAME SIGN ASSEMBLY PER CITY OF PORT. ST LUCIE STANDARD WITH UPPER/LOWER CASE LETTERS

STREET NAME SIGN ASSEMBLY PER CITY OF PORT. ST LUCIE STANDARD WITH UPPER/LOWER CASE LETTERS

SEE SHEET 16 - PAVEMENT MARKING MARSHALL PARKWAY PLANS

301 NW Flagler Ave.
Stuart, Florida 34994
Phone: (772) 892-4344
Fax: (772) 892-4341

Engineering Business
No. EB-007857
Civil Engineering Professionals

DATE: 8-24-22

DRAWN BY:	MDB
DESIGNED BY:	MDB
CHECKED BY:	###
PROJECT NO.:	2032
HORIZ. SCALE:	1" = 60'
VERT. SCALE:	1" = 60'
CADD FILE:	

NO.	DATE	BY	BID SET	REVISIONS
1	05-14-24	MDB		

SCALE VERIFICATION

0 0.5 1

SOLID BAR IS EQUAL TO HALF AN INCH ON DRAWING. ADJUST ALL SCALED DIMENSIONS ACCORDINGLY.

TOM MACKIE BLVD. EXTENSION
CITY OF PORT ST. LUCIE, FLORIDA

PAVEMENT MARKING AND SIGNAGE

Joseph W. Capra
301 N.W. Flagler Ave.
Stuart, Florida 34994
P.E. No. 37638

Printed Date:

PSLUSD # 11-900-23

JOB No.: 2032
SHEET 23 OF 34

PSL # P24-010

P:\2000\2032 - PSL Hegener Drive Phase 3\DWG\2032-UTILITY OVERALL.dwg, 5/17/2024 11:33:39 AM

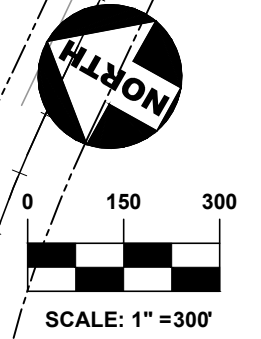
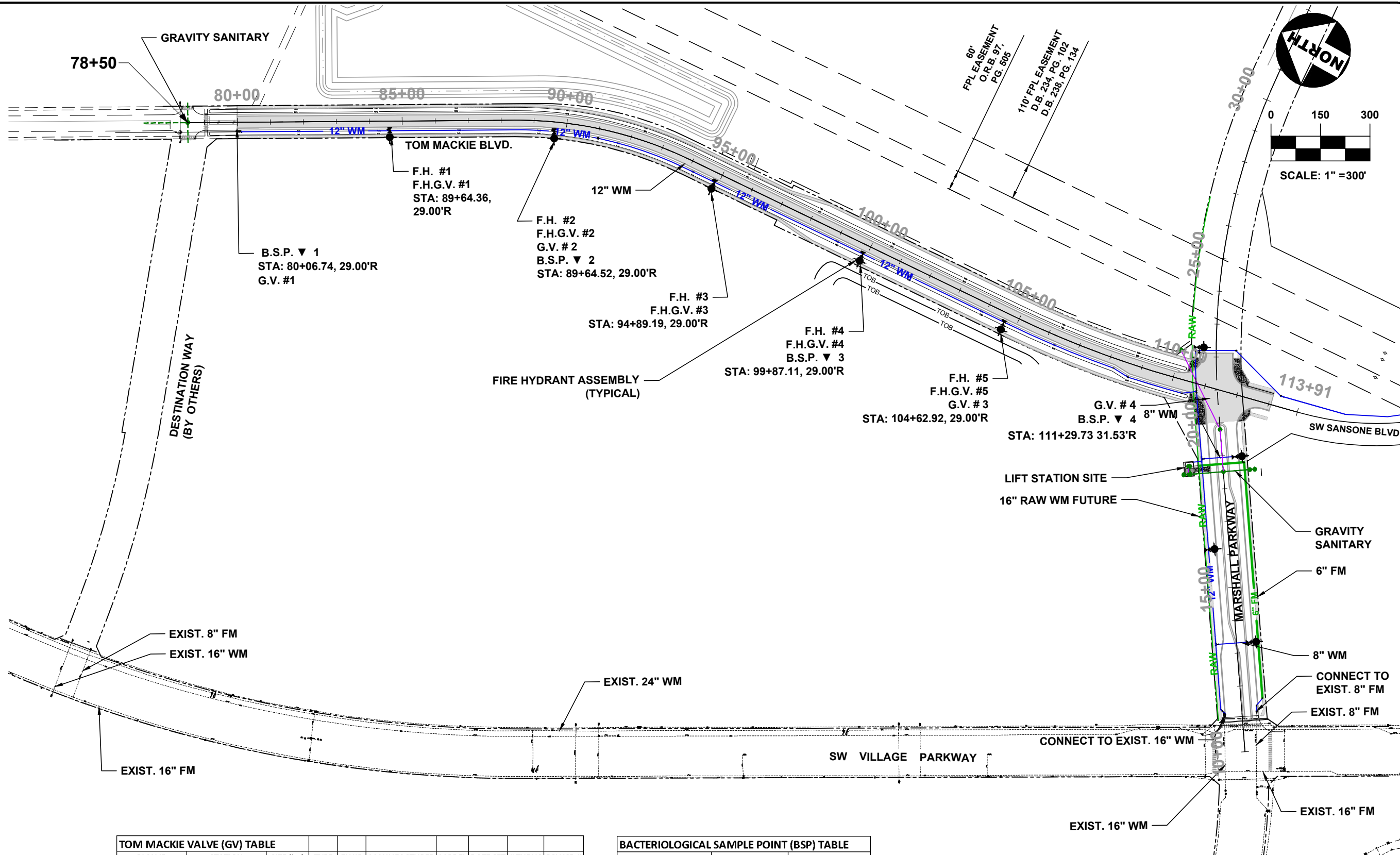

TOM MACKIE VALVE (GV) TABLE								
PLAN ID	STATION	SIZE (in.)	TYPE	FLUID	MANUFACTURER	MODEL	DATE SET	PSLUSD #
GV # 1	89+64.36, 29.00'R	12	GATE					
FHGV # 1	89+64.36, 29.00'R	8	GATE					
FHGV # 2	89+64.52, 29.00'R	8	GATE					
GV # 2	89+64.52, 29.00'R	12	GATE					
FHGV # 3	94+89.19, 29.00'R	8	GATE					
FHGV # 4	99+87.11, 29.00'R	8	GATE					
FHGV # 5	104+65.92, 29.00'R	8	GATE					
GV # 3	104+65.92, 29.00'R	12	GATE					
GV # 4	111+29.73 31.53'R	12	GATE					

BACTERIOLOGICAL SAMPLE POINT (BSP) TABLE		
NAME	STATION	DISTANCE
BSP # 1	80+06.74, 29.00'R	
BSP # 2	89+64.52, 29.00'R	958
BSP # 3	99+87.11, 29.00'R	1023
BSP # 4	111+29.73 31.53'R	1142

FHGV = FIRE HYDRANT / GATE VALVE

PSLUSD # 11-900-23

301 NW Flagler Ave.
Stuart, Florida 34994
Phone: (772) 892-4344
Fax: (772) 892-4341

Engineering Business
No. EB-007857
Civil Engineering Professionals

DATE:	8-24-22
DRAWN BY:	MDB
DESIGNED BY:	MDB
CHECKED BY:	JWC
PROJECT NO.:	2032
HORIZ. SCALE:	1" = 300'
VERT. SCALE:	
CADD FILE:	

NO.	DATE	BY	REVISIONS
1	05-01-24	MDB	100% PLANS

SCALE VERIFICATION

0 0.5 1

SOLID BAR IS EQUAL TO HALF AN INCH ON DIMENSIONS
DASHED BAR IS EQUAL TO ONE INCH ON DIMENSIONS
ADJUST ALL SCALED DIMENSIONS ACCORDINGLY

TOM MACKIE BLVD. EXTENSION
CITY OF PORT ST. LUCIE, FLORIDA

OVERALL UTILITY

Joseph W. Capra
301 N.W. Flagler Ave.
Stuart, Florida 34994
P.E. No. 37638

Printed Date:

JOB No.: 2032
SHEET
24 OF **34**

PSL # P24-010

P:\2000\2032 - PSL Hegener Drive Phase 3\DWG\2032-UTILITY.dwg, 5/17/2024 11:33:53 AM

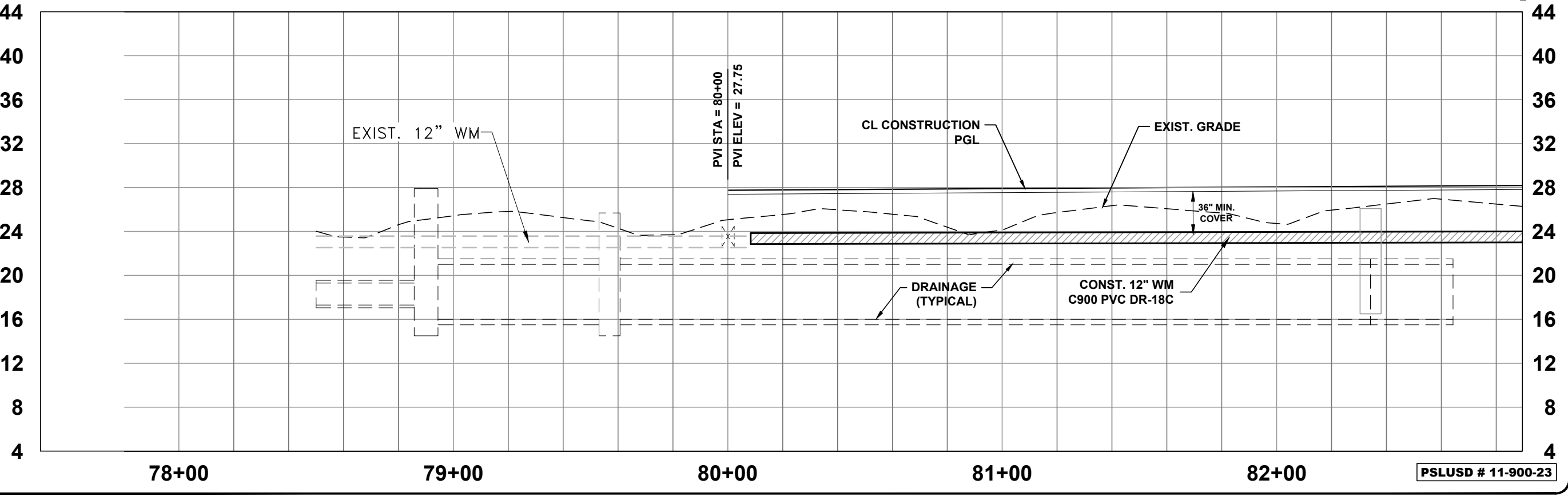
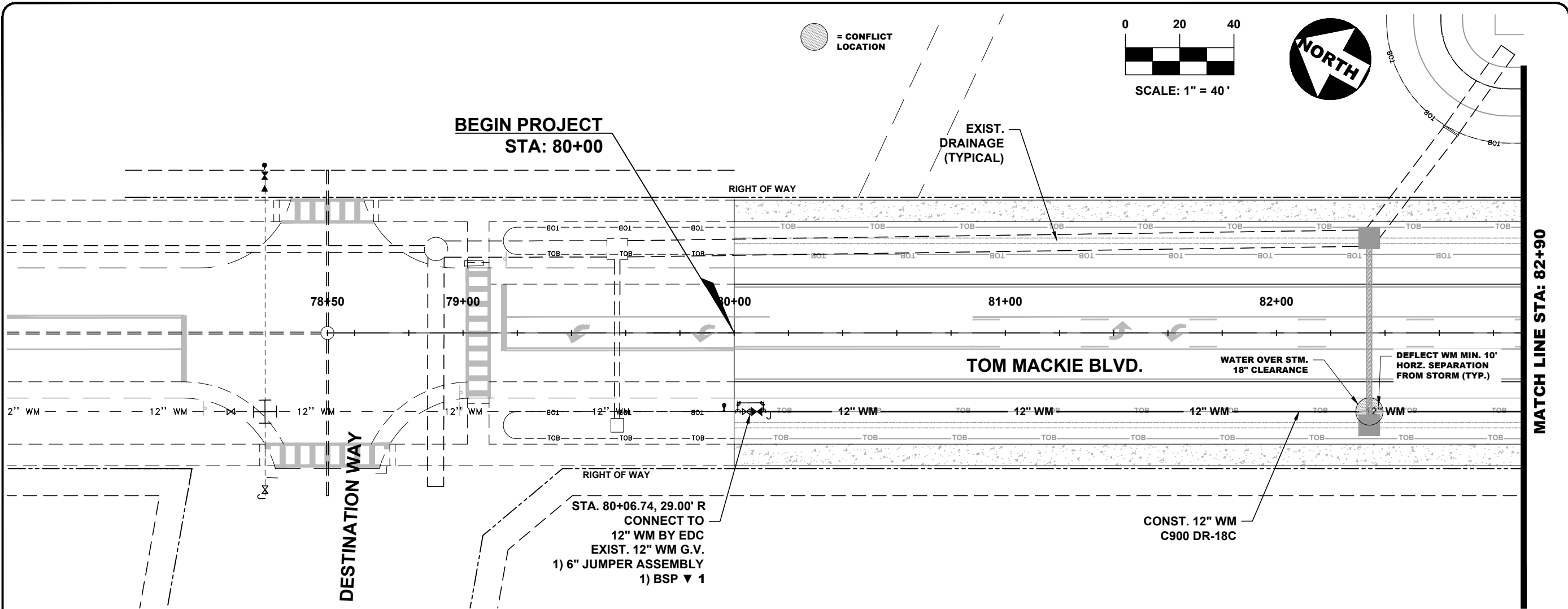

○ = CONFLICT LOCATION

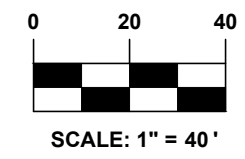

MATCH LINE STA: 82+90

301 N.W. Flagler Ave.
Stuart, Florida 34994
Phone: (772) 892-4344
Fax: (772) 892-4341

CAPTEC
Engineering, Inc.
Civil Engineering Professionals

DATE:	8-24-22
DRAWN BY:	MDB
DESIGNED BY:	MDB
CHECKED BY:	JWC
PROJECT NO.:	2032
HORIZ. SCALE:	1" = 40'
VERT. SCALE:	1" = 10'
CADD FILE:	

NO.	DATE	BY	REVISIONS
1	08-14-24	MDB	BID SET

SCALE VERIFICATION	0.5
SOLID BAR IS EQUAL TO HALF AN INCH ON ADJUST ALL SCALED DIMENSIONS ACCORDINGLY	

TOM MACKIE BLVD. EXTENSION
CITY OF PORT ST. LUCIE, FLORIDA

UTILITY PLAN

Joseph W. Capra
301 N.W. Flagler Ave.
Stuart, Florida 34994
P.E. No. 37638

Printed Date: _____
JOB No.: 2032
SHEET 25 OF 34

PSLUSD # 11-900-23

PSL # P24-010

P:\2000\2032 - PSL Hegener Drive Phase 3\DWG\2032-UTILITY.dwg, 5/17/2024 11:34:00 AM

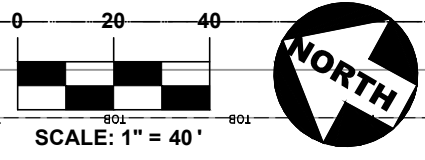
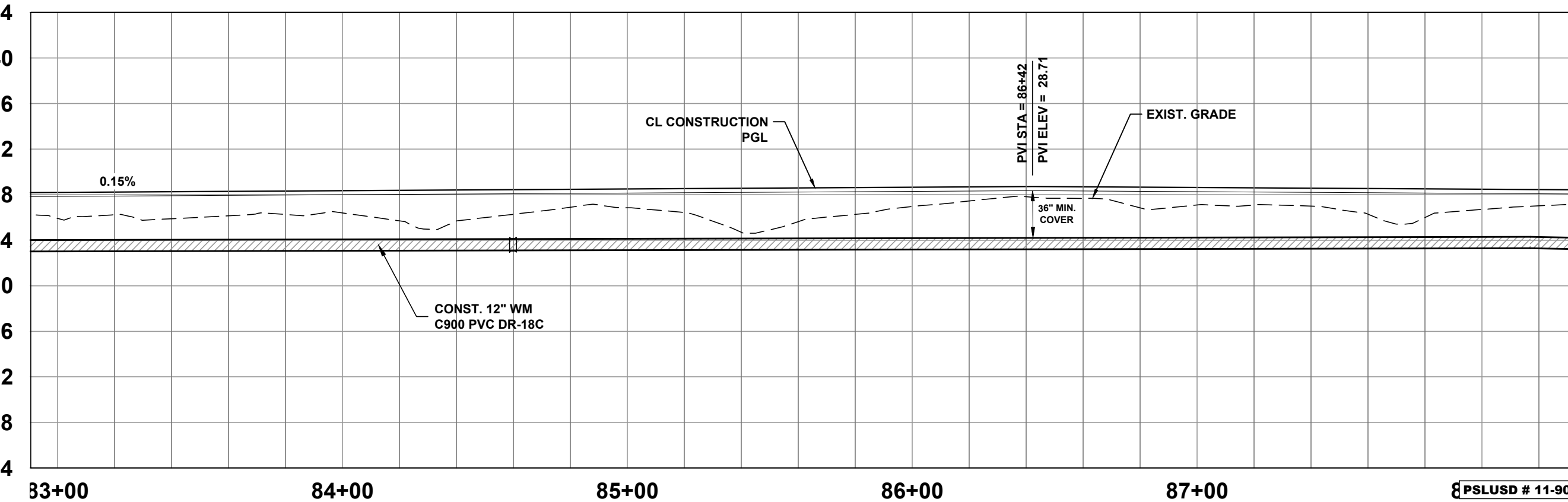
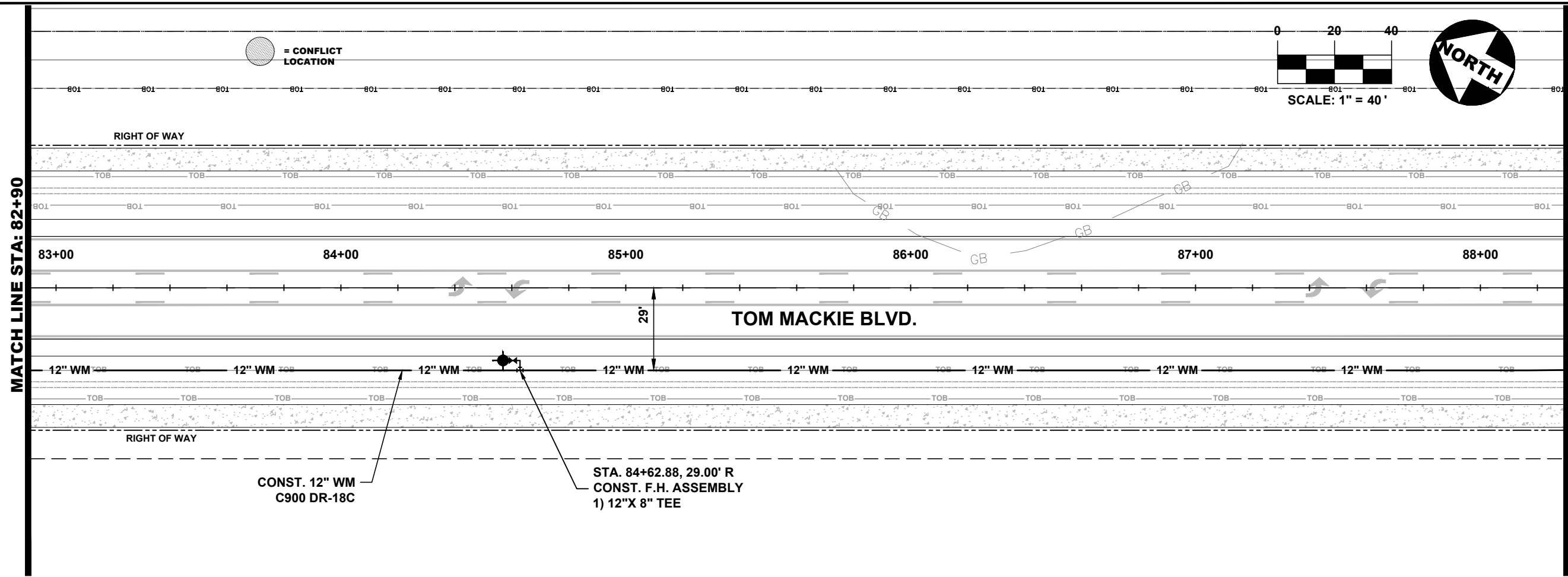

301 NW Flagler Ave.
Stuart, Florida 34994
Phone: (772) 892-4344
Fax: (772) 892-4341

CAPTEC
Engineering, Inc.
Civil Engineering Professionals

Engineering Business
No. EB-007857

DATE: 8-24-22

DRAWN BY: MDB

DESIGNED BY: MDB

CHECKED BY: JWC

PROJECT NO.: 2032

HORIZ. SCALE: 1" = 40'

VERT. SCALE: 1" = 10'

CADD FILE

NO.	DATE	BY	REVISIONS
1	05-14-24	MDB	BID SET

SCALE VERIFICATION

0 0.5

SOLID BAR IS EQUAL TO HALF AN INCH ON DIMENSIONS

DASHED BAR IS EQUAL TO ONE INCH ON DIMENSIONS

ADJUST ALL SCALED DIMENSIONS ACCORDINGLY

TOM MACKIE BLVD. EXTENSION
CITY OF PORT ST. LUCIE, FLORIDA

UTILITY PLAN

Joseph W. Capra
301 N.W. Flagler Ave.
Stuart, Florida 34994
P.E. No. 37638

Printed Date:

JOB No.: 2032
SHEET
26 OF **34**

PSLUSD # 11-900-23

P:\2000\2032 - PSL Hegener Drive Phase 3\DWG\2032-UTILITY.dwg, 5/17/2024 11:34:05 AM

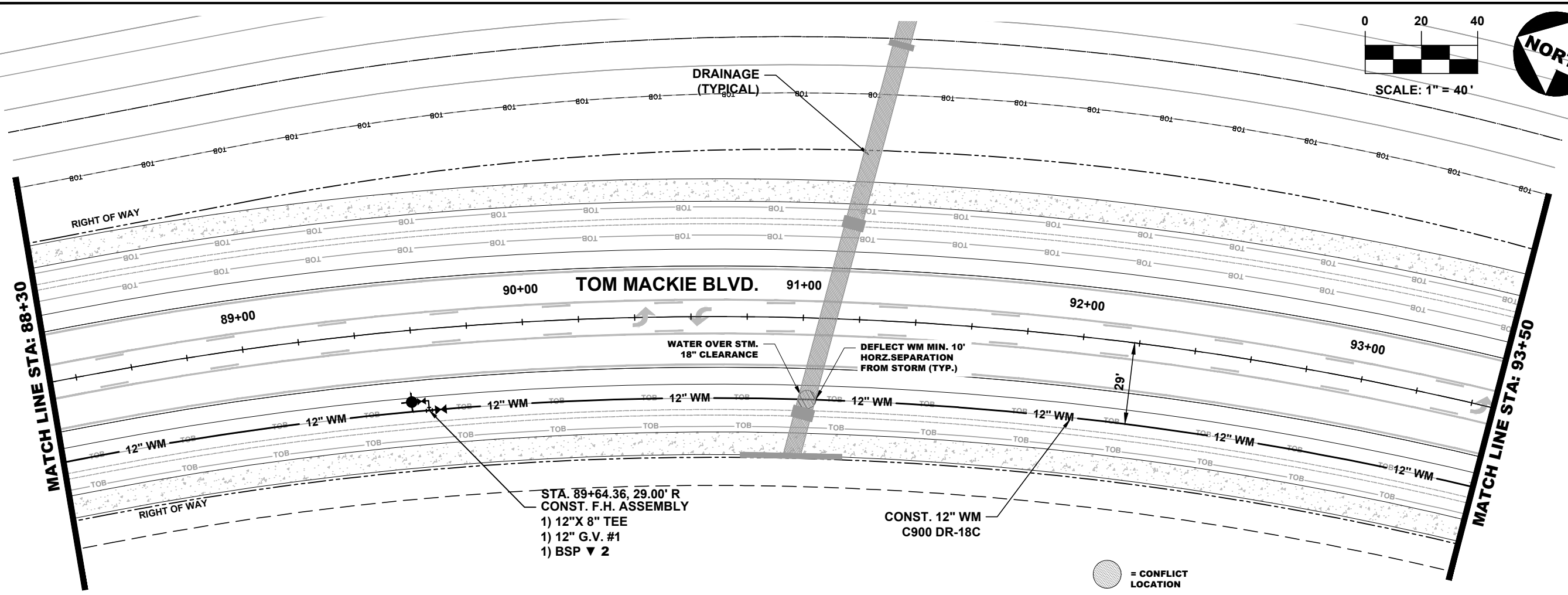

STA. 89+64.36, 29.00' R
CONST. F.H. ASSEMBLY
1) 12" X 8" TEE
1) 12" G.V. #1
1) BSP ▼ 2

○ = CONFLICT LOCATION

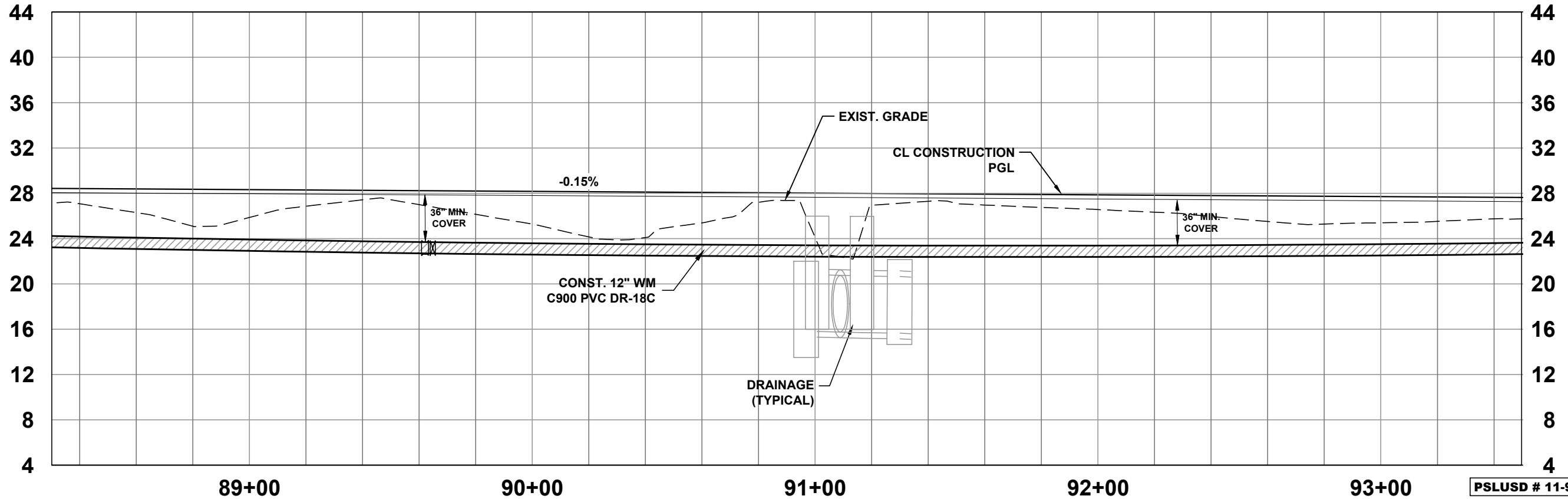

301 NW Flagler Ave.
Stuart, Florida 34994
Phone: (772) 892-4344
Fax: (772) 892-4341

Engineering Business
No. EB-007857
Civil Engineering Professionals

DATE: 8-24-22

DRAWN BY:	MDB
DESIGNED BY:	MDB
CHECKED BY:	JWC
PROJECT NO.:	2032
HORIZ. SCALE:	1" = 40'
VERT. SCALE:	1" = 10'

CADD FILE:

NO.	DATE	BY	REVISIONS
1	08-14-24	MDB	BID SET

SCALE VERIFICATION

SOLID BAR IS EQUAL TO HALF AN INCH ON ADJUST ALL SCALED DIMENSIONS ACCORDINGLY

TOM MACKIE BLVD. EXTENSION
CITY OF PORT ST. LUCIE, FLORIDA

UTILITY PLAN

Joseph W. Capra
301 N.W. Flagler Ave.
Stuart, Florida 34994
P.E. No. 37638

Printed Date:

JOB No.: 2032
SHEET 27 OF 34

PSLUSD # 11-900-23

PSL # P24-010

P:\2000\2032 - PSL Hegener Drive Phase 3\DWG\2032-UTILITY.dwg, 5/17/2024 11:34:10 AM

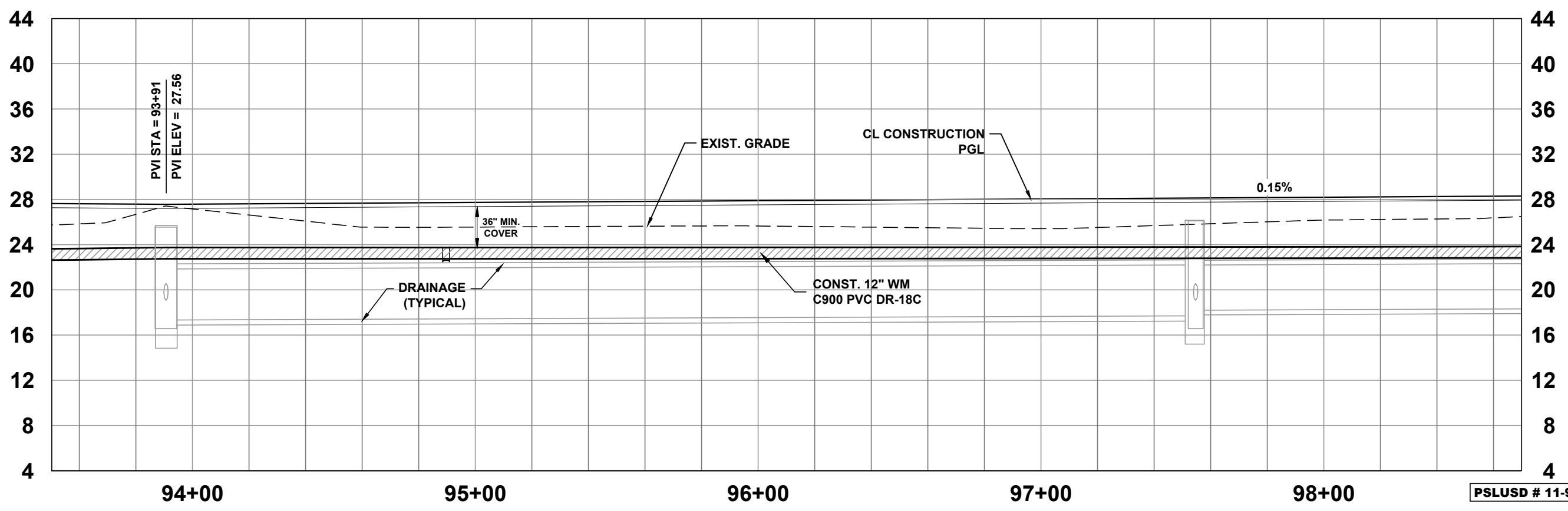
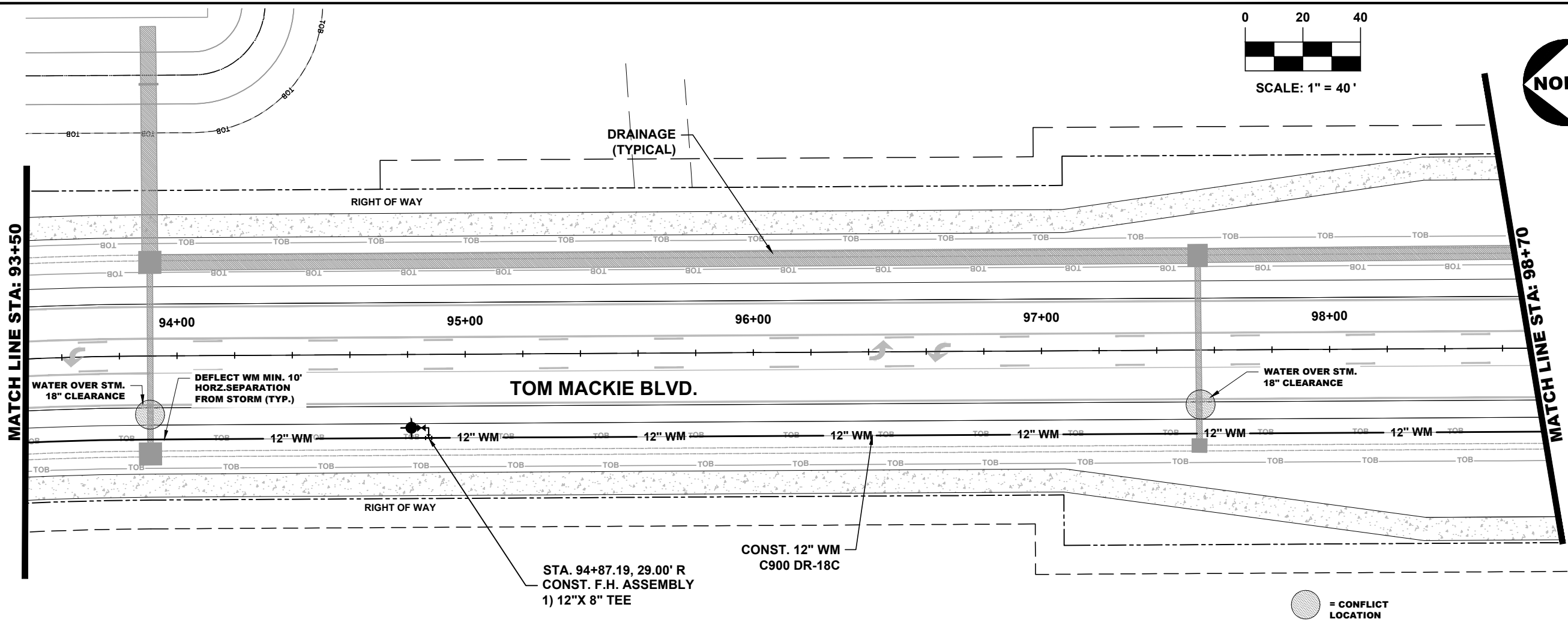
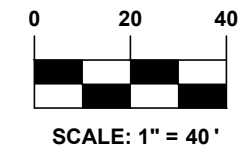

301 NW Flagler Ave.
Stuart, Florida 34994
Phone: (772) 892-4344
Fax: (772) 892-4341

Engineering Business
No. EB-007857
Civil Engineering Professionals

DATE: 8-24-22

DRAWN BY:	MDB
DESIGNED BY:	MDB
CHECKED BY:	JWC
PROJECT NO.:	2032
HORIZ. SCALE:	1" = 40'
VERT. SCALE:	1" = 10'

CADD FILE:

NO.	DATE	BY	REVISIONS
1	05-14-24	MDB	BID SET

SCALE VERIFICATION

SOLID BAR IS EQUAL TO HALF AN INCH ON ALL DIMENSIONS ADJUST ALL SCALED DIMENSIONS ACCORDINGLY

TOM MACKIE BLVD. EXTENSION
CITY OF PORT ST. LUCIE, FLORIDA

UTILITY PLAN

Joseph W. Capra
301 N.W. Flagler Ave.
Stuart, Florida 34994
P.E. No. 37638

Printed Date:

JOB No.: 2032
SHEET 28 OF 34

PSLUSD # 11-900-23

PSL # P24-010

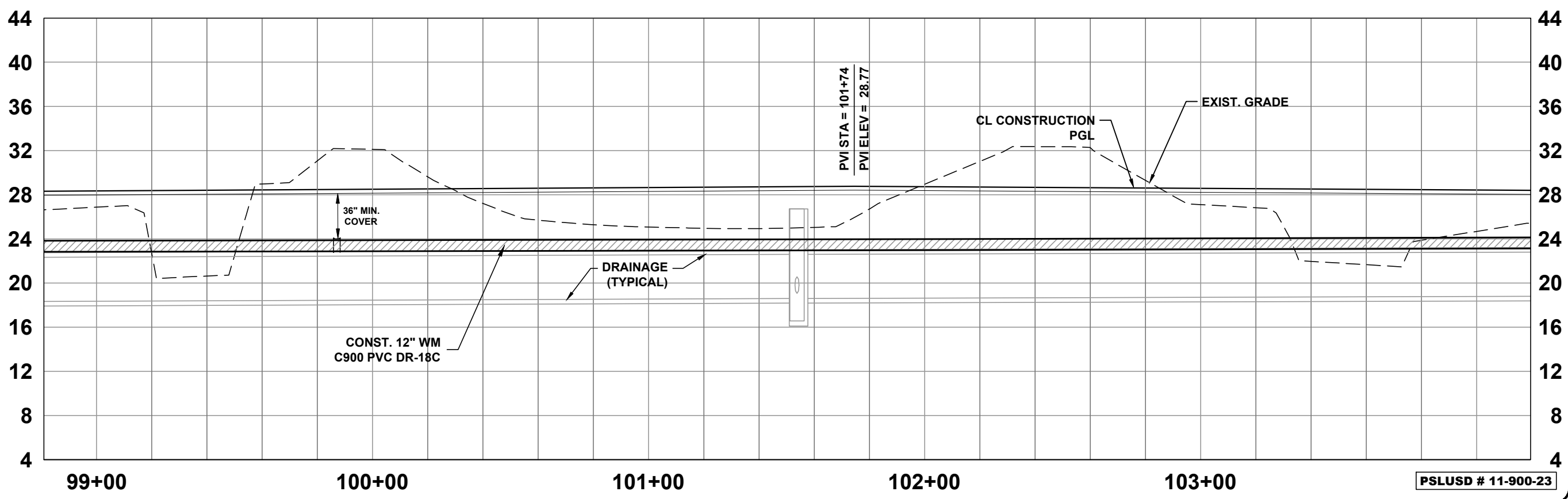
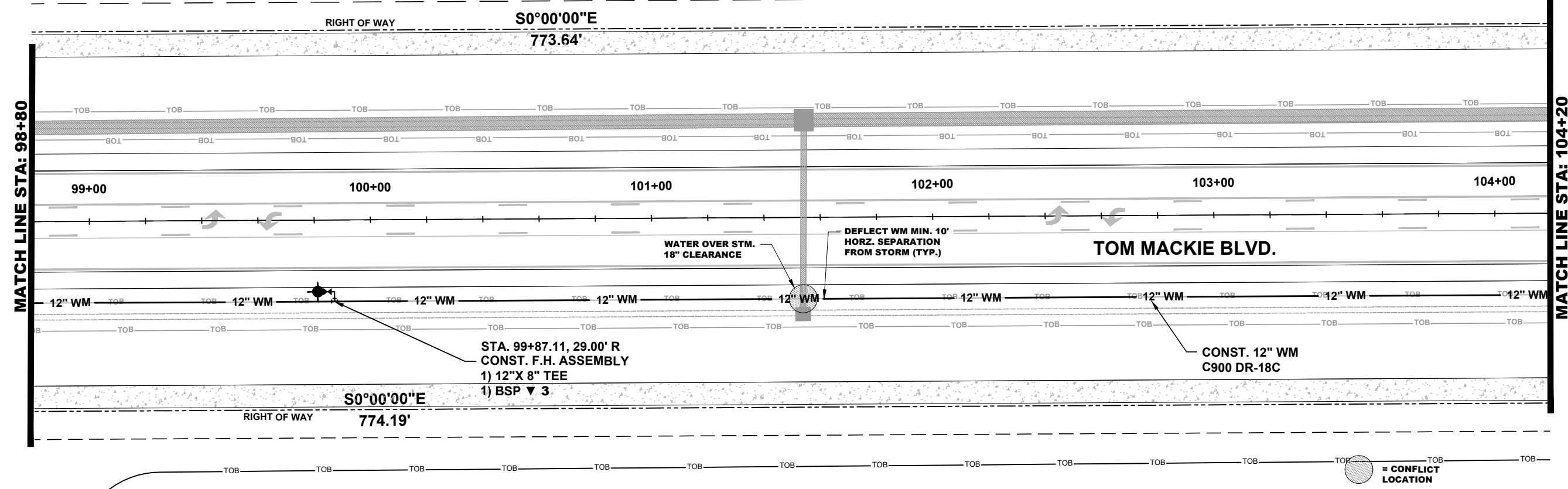
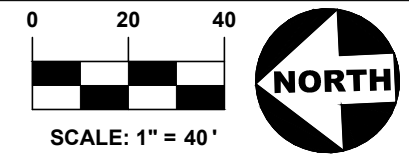

301 N.W. Flagler Ave.
Stuart, Florida 34994
Phone: (772) 892-4344
Fax: (772) 892-4341

Engineering Business
No. EB-007857
Civil Engineering Professionals

DATE: 8-24-22

DRAWN BY:	MDB
DESIGNED BY:	MDB
CHECKED BY:	JWC
PROJECT NO.:	2032
HORIZ. SCALE:	1" = 40'
VERT. SCALE:	1" = 10'

CADD FILE:

NO.	DATE	BY	REVISIONS
1	08-14-24	MDB	BID SET

SCALE VERIFICATION

SOLID BAR IS EQUAL TO HALF AN INCH ON DRAWING. ADJUST ALL SCALED DIMENSIONS ACCORDINGLY.

TOM MACKIE BLVD. EXTENSION
CITY OF PORT ST. LUCIE, FLORIDA

UTILITY PLAN

Joseph W. Capra
301 N.W. Flagler Ave.
Stuart, Florida 34994
P.E. No. 37638

Printed Date:

JOB No.: 2032
SHEET 29 OF 34

P:\2000\2032 - PSL Hegener Drive Phase 3\DWG\2032-UTILITY.dwg, 5/17/2024 11:34:15 AM

P:\2000\2032 - PSL Hegener Drive Phase 3\DWG\2032-UTILITY.dwg, 5/17/2024 11:34:20 AM

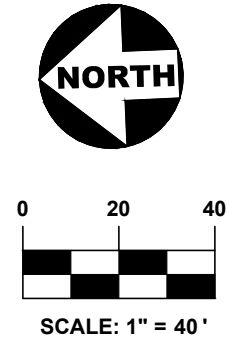
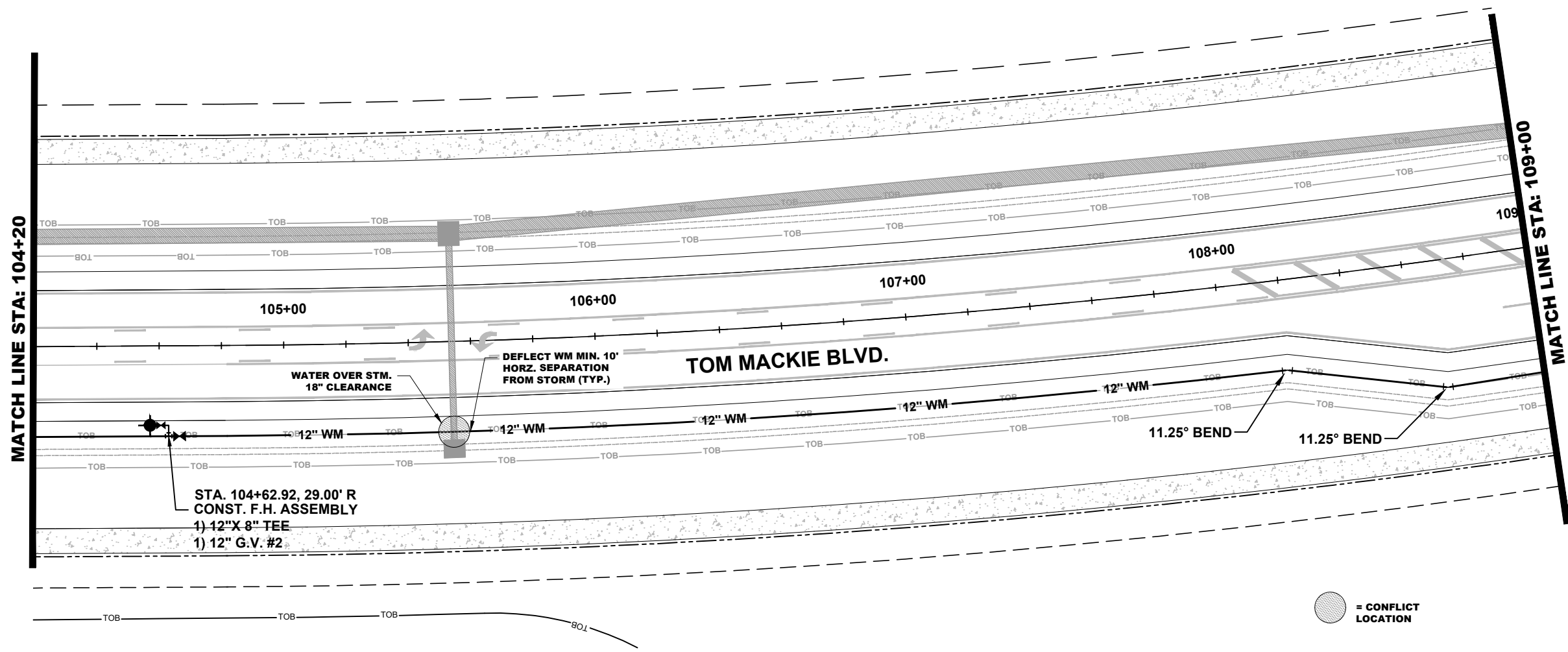

301 NW Flagler Ave.
Stuart, Florida 34994
Phone: (772) 892-4344
Fax: (772) 892-4341

CAPTEC
Engineering, Inc.
Civil Engineering Professionals

Engineering Business
No. EB-007857

DATE: 8-24-22

DRAWN BY:	MDB
DESIGNED BY:	MDB
CHECKED BY:	JWC
PROJECT NO.:	2032
HORIZ. SCALE:	1" = 40'
VERT. SCALE:	1" = 10'
CADD FILE:	

NO.	DATE	BY	REVISIONS
1	08-14-24	MDB	BID SET

SCALE VERIFICATION

0 0.5

SOLID BAR IS EQUAL TO HALF AN INCH ON DIMENSIONS
DASHED BAR IS EQUAL TO ONE INCH ON DIMENSIONS
ADJUST ALL SCALED DIMENSIONS ACCORDINGLY

TOM MACKIE BLVD. EXTENSION
CITY OF PORT ST. LUCIE, FLORIDA

UTILITY PLAN

Joseph W. Capra
301 N.W. Flagler Ave.
Stuart, Florida 34994
P.E. No. 37638

Printed Date:

JOB No.: 2032
SHEET
30 OF **34**

PSLUSD # 11-900-23

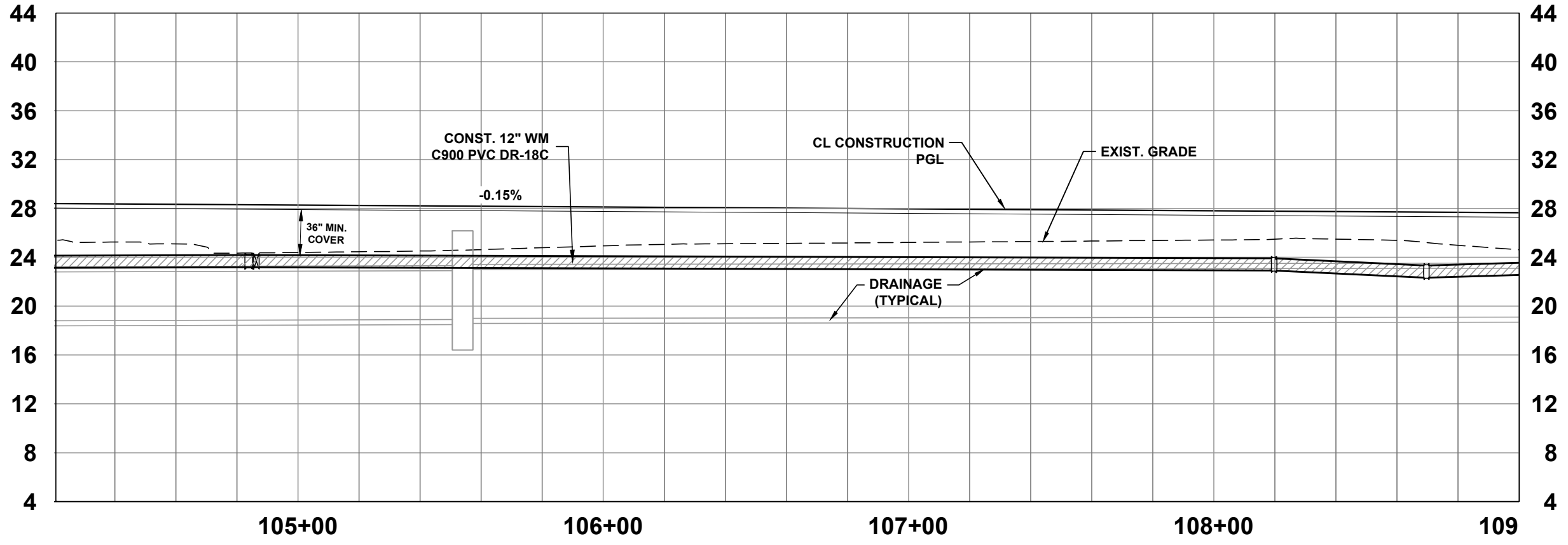

P:\2000\2032 - PSL Hegener Drive Phase 3\DWG\2032-UTILITY.dwg, 5/17/2024 11:34:25 AM

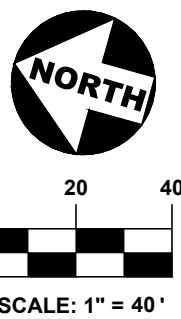
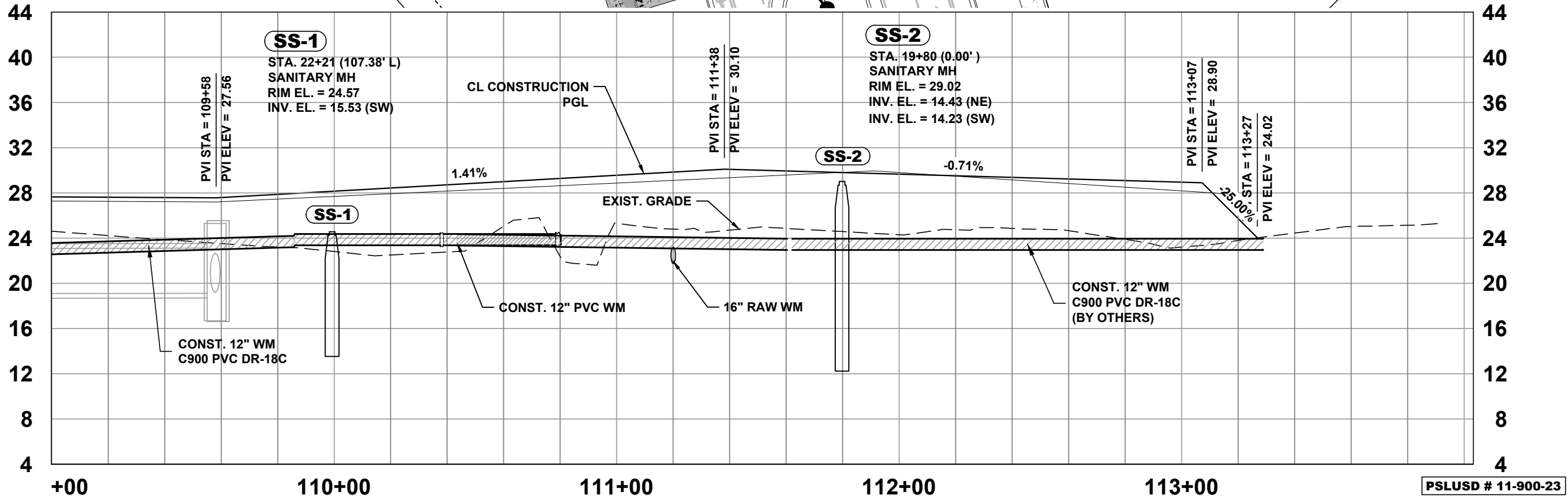
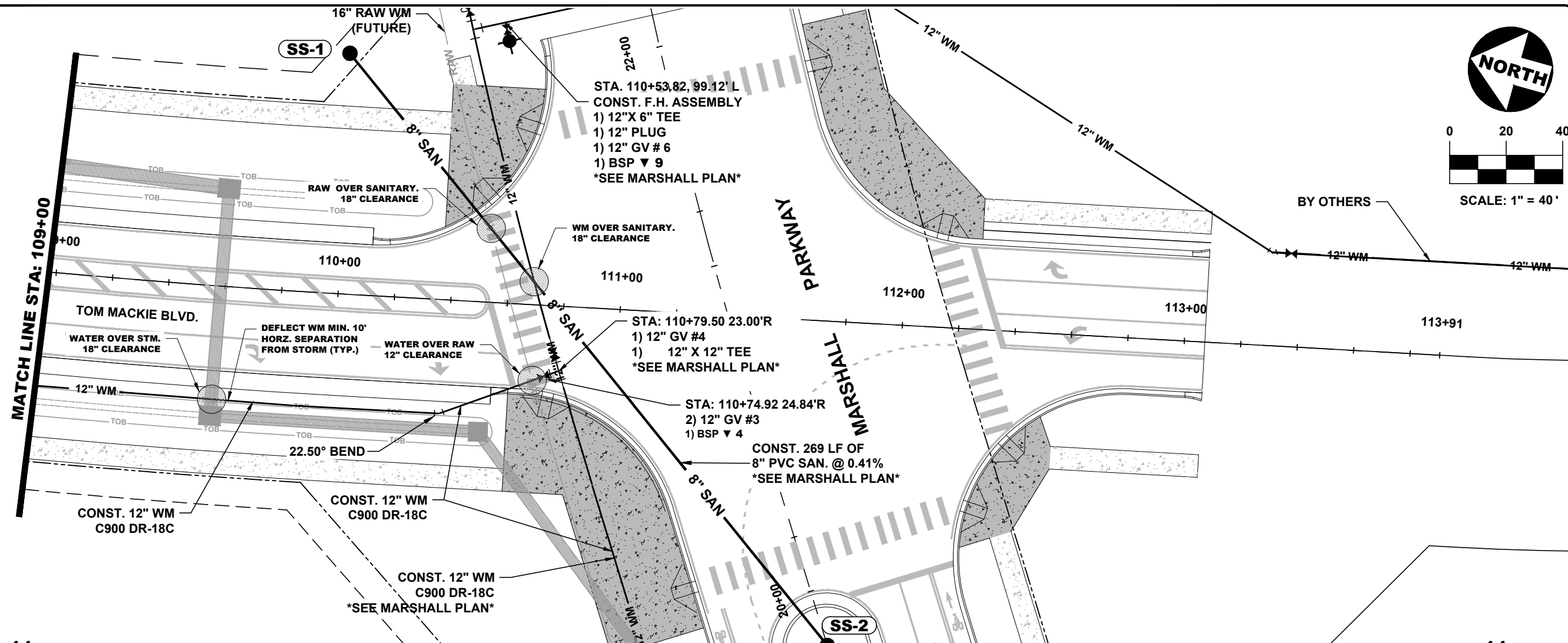

301 N.W. Flagler Ave.
Stuart, Florida 34994
Phone: (772) 892-4344
Fax: (772) 892-4341

Engineering Business
No. EB-007857
Civil Engineering Professionals

DATE: 8-24-22

DRAWN BY:	MDB
DESIGNED BY:	MDB
CHECKED BY:	JWC
PROJECT NO.:	2032
HORIZ. SCALE:	1" = 40'
VERT. SCALE:	1" = 10'

CADD FILE:

NO.	DATE	BY	REVISIONS
1	05-14-24	MDB	BID SET

SCALE VERIFICATION

SOLID BAR IS EQUAL TO HALF AN INCH ON ADJUST ALL SCALED DIMENSIONS ACCORDINGLY

TOM MACKIE BLVD. EXTENSION
CITY OF PORT ST. LUCIE, FLORIDA

UTILITY PLAN

Joseph W. Capra
301 N.W. Flagler Ave.
Stuart, Florida 34994
P.E. No. 37638

Printed Date:

JOB No.: 2032
SHEET
31 OF **34**

PSLUSD # 11-900-23

P:\2000\2032 - PSL Hegener Drive Phase 3\DWG\2032 Gen Notes.dwg, 5/17/2024 11:34:32 AM

DESIGN SPECIFICATIONS AND CONSTRUCTION STANDARDS

A. GENERAL

- The standards set forth in this manual are intended to provide a basis for design and construction. Applicable federal, state and local laws and regulations should be considered the Engineer of Record (EOR) and requires a written approval from the PSLUSD prior to construction plan submittal. Approval of construction plans by the PSLUSD does not constitute written approval of deviations from the utility standards.
- All references to stainless steel shall refer to grade 316 unless otherwise noted.
- Water, wastewater and reclaimed water lines shall not be constructed without first obtaining an approval or permit, as applicable, from the PSLUSD and/or FDEP.
- All construction shall be in accordance with this manual, the City of Port St. Lucie Code of Ordinances, and with all applicable Florida Department of Environmental Protection (FDEP) rules and regulations. If any conflict exists between the standards, the more stringent governs, as determined by the PSLUSD. Copies of City Code of Ordinances are available with the City Clerk's office and can also be accessed online at www.cityofpsl.com. The FDEP rules are available online www.dep.state.fl.us.
- Construction shall be in accordance with the utility standards in effect at the time the project was approved by the PSLUSD and will not be subject to changes in the standards during the life of the project.
- Wastewater discharge shall be subject to Port St. Lucie wastewater system user rules in accordance with the City of Port St. Lucie Code of Ordinances - Title VI.
- All abandoned mains and service lines shall be removed or filled with cement grout. Unless noted otherwise on the plans Asbestos cement pipe (ACP) must be handled in compliance with applicable federal, state and local regulations. All cutting, removal, and disposal of ACP shall be performed by a Florida licensed Asbestos Abatement Contractor.
- The design and construction of privately owned fire lines shall conform to the St. Lucie County Fire District standards (www.slcfcd.com) pertaining to dedicated fire sprinkler systems; the District has final jurisdiction on all hydrant and fire sprinkler line requirements. A plan approved by the District is required to be submitted at the pre-construction meeting with any revision that relocates a hydrant or a fire line connection.
- Cross connection control shall be provided in compliance with City of Port St. Lucie Code of Ordinances – Title VI and FDEP regulations.
- Permits shall be obtained for sub-aqueous and aerial pipe crossings canals 1 and other surface waters from jurisdictional agencies and construction shall be in accordance with the permitted plans and conditions.

D. SEPARATION BETWEEN PSLUSD MAINS AND OTHER UTILITIES

The minimum separation between PSLUSD mains and other utilities, as measured from the outside of each pipe, shall be as follows:

- Water mains shall be located a minimum of 10' from a gravity sewer, force main and reclaimed water main. The vertical separation shall be at least 18" with the water main crossing over the other pipes.
- All PSLUSD pipes shall have a minimum horizontal separation of 5' from all other underground utilities and a vertical separation of at least 18".
- When gravity sewer is to be installed parallel to a drainage pipe greater than 15" in diameter, a minimum horizontal separation of 15' shall be maintained. A greater separation may be required for drainage pipes larger than 24" in diameter, as determined by PSLUSD.
- When force main or reclaimed water main is to be installed parallel to a drainage pipe, a minimum horizontal separation of 8' shall be maintained. A greater separation may be required for drainage pipes larger than 48" in diameter.

CONSTRUCTION COORDINATION, INSPECTIONS AND TESTING

A. GENERAL

- The Engineer of Record (EOR) shall have a pre-construction meeting with the PSLUSD and the contractor prior to starting construction. The meeting shall be held at the Utility Department Office.
- The EOR shall coordinate all construction and inspections on the project and shall be the point of contact with PSLUSD. Testing shall be conducted by or at the direction of the EOR in the presence of a PSLUSD inspector.
- The contractor shall contact the EOR, the appropriate governmental jurisdictional agency, and all utility companies at least 48 hours prior to commencement of construction for coordination of any utilities.
- There shall be no field changes or deviations from design without prior written approval of the PSLUSD and EOR.
- All materials, construction methods, testing, and disinfection shall conform to the requirements of the PSLUSD and AWWA current standards.
- Density test results shall be submitted to the PSLUSD no later than 7 calendar days from the date the test was taken. The inspections required in this Chapter shall not be scheduled by PSLUSD, as noted in Section B.2.d. until such time as the density test results have been approved by the PSLUSD.
- It is the EOR's responsibility to coordinate the installation of other public utilities near the PSLUSD facilities.
- The contractor shall strictly adhere to the horizontal and vertical separation requirements specified in the PSLUSD utility standards and applicable standard detail. All crossings between PSLUSD facilities as well as with other utilities shall be left exposed until observed by a PSLUSD inspector.
- Contractor shall adhere to the approved Maintenance of Traffic Plan at all times where work is in progress. Traffic control, barricades, etc., shall be in accordance with applicable permits, local regulations and Florida Department of Transportation and OSHA standards.
- Contractor shall repair any damage caused to existing utilities by construction activity in accordance with applicable standards
- No pollution or erosion caused by this project will be allowed off site or in the stormwater drainage system. The contractor shall install any devices necessary to prevent pollution or erosion and comply with the City's code for erosion and sediment control standards. The cost of pollution and erosion control shall be incidental to the cost of construction.

B. INSPECTIONS 1 & TESTING

The EOR shall perform inspections, observations, and tests necessary to assure compliance with utility standards; complete the required PSLUSD forms for inspections and testing; and certify completion of the utility facilities. The contractor shall not cover newly constructed facilities prior to a required inspection being conducted by the EOR and the PSLUSD. If any construction is covered before an inspection by PSLUSD, the contractor shall be required to uncover it at his expense. All work that has been rejected or condemned shall be repaired, or if it cannot be satisfactorily repaired, shall be removed and replaced at the contractor/developer's expense. Materials not conforming to the requirements of the specifications shall be removed immediately from the site of work and replaced with satisfactory material by the contractor/developer. The PSLUSD shall have the right to require additional inspections, certifications and/or testing to confirm that the deficient work has been corrected.

1. PSLUSD INSPECTOR'S AUTHORITY

- The PSLUSD inspections are intended to make observations for verification of compliance and do not relieve the EOR or contractor from fulfilling their responsibilities. Any items found to be deficient after PSLUSD has passed an inspection will still require correction at the contractor/developer's expense.
- The PSLUSD inspector is not authorized to revoke, alter or waive any requirements of the specifications, but is authorized and expected to call to the attention of the EOR and/or contractor any failure of work or materials to conform to the plans or specifications. The PSLUSD inspector does NOT have the authority to make changes to the approved plans. The inspector shall have the authority to reject materials or suspend the work until questions of issue can be referred to and decided upon by the Utility Director or his designated representative.
- The inspector shall in no case either act as foreman or perform other duties for the EOR and/or contractor nor interfere with the management of the work. Advice that the inspector may give shall in no way be construed as binding to the City of Port St. Lucie or releasing the developer, his engineer or contractor from performing according to the intent of the plans and minimum PSLUSD Standards.

2. SCHEDULING OF INSPECTIONS

a. It shall be the responsibility of the EOR to schedule inspections and their qualified representative shall be present at all scheduled tests and inspections. Pre-testing is encouraged to be completed prior to scheduled inspections, to minimize failures. A scheduled inspection will be canceled, and a re-inspection fee assessed if one of the three following situations occurs:

- Failure to show for inspection by the EOR or contractor,
- Cancellation of the inspection with less than 24 hours notice,
- A failing test result.

Re-inspection fees shall be assessed per scheduled hour of the inspection; the exception is for TV inspection of gravity sewer, for which the re-inspection fee will be assessed on the hours scheduled for the repairs and the TV inspection. The EOR will be notified or given a Failed Inspection Notice at the time of the failed inspection. All re-inspection fees shall 1 be paid to the PSLUSD prior to any subsequent scheduling of further inspections.

The PSLUSD shall be provided with at least two (2) full working days notice for scheduled inspections. Inspectors will make unscheduled visits as needed to observe such items as ongoing work on site, restraints and clearances between conflicting lines.

b. Scheduled inspections will be conducted during normal business hours, Monday through Friday, except when service disruptions are anticipated. When progress of a project requires, for the convenience of the contractor, the periodic presence of a PSLUSD representative during after hours, weekends and/or city holidays, the contractor/developer shall accept the financial responsibility for the overtime hours (at overtime rates) with a minimum of four (4) hours, including travel time.

c. The required inspections for items marked with an asterisk below shall not be scheduled until such time as the density test results, as-built drawings, asset list, and easements have been submitted and approved by the PSLUSD.

1. REQUIRED INSPECTIONS (In no specific order)

Scheduled inspections are required for the following:

- Materials Inspection
- Connection to existing mains, tie-ins, wet taps, etc
- Jack & Bores and installation of the carrier pipes, Directional Drilling, Directional Boring and any other type of bore.
- Restraints & Conflicts
- Flushing (Pigging)
- Pressure/Leak Testing *
- Chlorination Test
- Disinfection
- Removal and plugging of sample points
- Fire Hydrant Flow Test
- Wire Trace Continuity and electronic marker verification
- Any re-construction repairs and field changes, including lines that have not been turned over to the PSLUSD
- Concrete pad formwork/rebar placement
- Installation of the first manhole of the lift station and the first manhole to be installed TV Inspection (gravity sewer)
- Infiltration/Ex-filtration Test Report (gravity sewer, manholes, pump stations and grease interceptors) *
- Spark testing manhole liners
- Deflection Test
- Installation of lift station/grinder structures/valve vault/grease interceptor
- Electrical components of pump station
- Pump Station Start-up
- Any re-construction repairs and field changes, including lines that have not been turned over to the PSLUSD
- Liner Welding and spark testing
- Backflow Assembly Certification
- Final Inspection

The PSLUSD forms for the scheduled inspections noted above shall be completed 1 by the EOR and submitted to PSLUSD with a sealed and signed cover letter. The forms are can be downloaded from the city's website at <http://www.cityofpsl.com/utility/commercial-development/utility-commercial-development.html> .

The PSLUSD forms for the scheduled inspections noted above shall be completed 1 by the EOR and submitted to PSLUSD with a sealed and signed cover letter. The forms are can be downloaded from the city's website at <http://www.cityofpsl.com/utility/commercial-development/utility-commercial-development.html> .

All pipe restraints and crossings shall be left exposed until inspected and approved by the PSLUSD. Such inspections may be combined with scheduled inspections or will be conducted at a separate scheduled time.

PSLUSD # 11-900-23

301 NW Flagler Ave.
Stuart, Florida 34994
Phone: (772) 892-4344
Fax: (772) 892-4341



Engineering Business
No. EB-007857

DATE:	8-24-22
DRAWN BY:	MDB
DESIGNED BY:	MDB
CHECKED BY:	JWC
PROJECT NO.:	2032
HORIZ. SCALE:	N/A
VERT. SCALE:	N/A
CADD FILE:	

NO.	DATE	BY	REVISIONS
1	08-14-24	MDB	BID SET

SCALE VERIFICATION



SOLID BAR IS EQUAL TO HALF AN INCH ON DRAWING. ADJUST ALL SCALED DIMENSIONS ACCORDINGLY

TOM MACKIE BLVD. EXTENSION
CITY OF PORT ST. LUCIE, FLORIDA

PSLUSD GENERAL NOTES

Joseph W. Capra
301 N.W. Flagler Ave.
Stuart, Florida 34994
P.E. No. 37638

Printed Date:
JOB No.: 2032
SHEET
32 OF **34**

P:\2000\2032 - PSL Hegener Drive Phase 3\DWG\2032 Gen Notes.dwg, 5/17/2024 11:34:34 AM

4. REQUIRED TESTING

The testing for various components of the water, wastewater and reclaimed water system components shall be performed as detailed below. The EOR shall provide the PSLUSD with written test results on PSLUSD forms noted above in 3.a. & b. for each required test with a signed and sealed cover letter from the EOR in the Final Inspection package. During construction, the individual test reports shall be submitted to the City in pdf format, via email within 7 calendar days of the test.

a. Performance testing of pressure pipe

(1) Type of Testing

The following performance testing must be conducted:

- (a) Water Main: Hydrostatic, Leakage and Bacteriological Testing
(b) Force Main: Hydrostatic, and Leakage Testing
(c) Low Pressure Main: Hydrostatic, and Leakage Testing

(2) References - Testing shall be performed in accordance with the following references:

- (a) ANSI/AWWA C600 - Standard for Ductile Iron Pipe Installation and Testing.
(b) ANSI/AWWA C605 - Standard for Polyvinyl Chloride (PVC) Pipe Installation and Testing
(c) ANSI/AWWA C651 - Standard for Disinfecting Water Mains.
(d) ANSI/AWWA C900 - Standard for PVC Pipe, 4"-12" for Water Distribution.
(e) ANSI/AWWA C905 - Standard for PVC Pipe 14" & above for Water Distribution.

(3) Regulations - No leak testing shall be performed until easements, as-built drawings, and density tests have been submitted and accepted by the City. Testing shall conform to PSLUSD requirements and FDEP regulations.

(4) Temporary Connection to PSLUSD Water Main

(a) A temporary jumper connection is required between an existing active water main and a newly constructed main until a clearance is obtained from the PSLUSD. The temporary connection shall be used at point (s) of filling in accordance with the standard details for potable and non-potable water jumper connection.

(b) The EOR shall contact the PSLUSD via e-mail at (inspectors@cityofpsl.com) regarding scheduling of required inspections listed in this chapter or any other inspections deemed necessary by the PSLUSD and shall strictly follow all procedures detailed in this chapter.

(c) The temporary jumper assembly (flange to flange) will be supplied, installed and tested by the PSLUSD, in coordination with the EOR and contractor. Other materials and installation required for the connection shall be responsibility of the contractor. The contractor shall disinfect the tapping sleeve and exterior of the main to be tapped by spraying and swabbing with chlorine in the presence of a PSLUSD inspector. The underground fittings shall be restrained mechanical joint type. All materials shall be per the PSLUSD approved Qualified Products List.

(d) The jumper connection shall be maintained by the contractor until filling, flushing, hydrostatic pressure/leakage testing, disinfection and bacteriological sampling have been satisfactorily completed by the contractor and the test results are in compliance with the PSLUSD and FDEP standards. Disinfection and bacteriological sampling is not required for newly constructed force mains and reclaimed water mains.

(e) A physical separation shall be maintained between an existing water main and the newly constructed water main, except as noted herein. If the new main is of a size or length that pigging/flushing cannot be effectively accomplished with the jumper connection, the PSLUSD may allow a physical connection under controlled conditions as follows:

- (i) The procedure will be conducted by the contractor in the presence of a PSLUSD inspector and the Engineer-of-Record (EOR) or representative.
(ii) The new valve(s) shown in this detail shall be pressure/leakage tested and replaced if leakage is observed. The valves will be kept closed by the PSLUSD and shall not be operated by any one other than PSLUSD personnel.
(iii) The jumper connection shall be used to fill the new main.

(iv) The contractor shall disinfect the pipe and fittings used to make the connection by spraying and swabbing with chlorine.

(v) All valves in the new system downstream of the jumper shall be opened by the contractor prior to flushing. The valves shown in the standard detail shall be opened by PSLUSD personnel only.

(vi) The pigging and flushing shall be performed by the contractor in the presence of a PSLUSD inspector. The valves will be closed by PSLUSD personnel after the main has been flushed.

(vii) The main shall be pressure tested after flushing and prior to disinfection. All valves shall be kept closed during the pressure test and will be opened by PSLUSD personnel if the test results are satisfactory.

(viii) Disinfection shall be conducted in accordance with AWWA C651. A minimum pressure of 20 psi shall be maintained in the new water main after disinfection.

(f) Bacteriological sampling and testing of the new water main shall be conducted 1 per section B.4a.(8) of this Chapter and a clearance obtained from the PSLUSD or FDEP, as applicable. The sampling points shall be removed and plugged, and the permanent connection made by the contractor. The contractor shall disinfect the pipe and fittings used to make the connection by spraying and swabbing with chlorine.

(g) The PSLUSD will remove the jumper assembly (flange to flange) after the corporation stop valves to the jumper have been closed; the valves shall be plugged by the contractor after removal of the assembly.

(h) The contractor shall pay the PSLUSD for all the water used, based on the initial and final reading of the water meter.

(5) Cleaning/Flushing

(a) Flushing shall be conducted to clean the mains and remove all foreign matter.

(b) For water mains, flushing shall be conducted prior to disinfection. Hoses, fittings and temporary pipes in ditches shall be provided as required to dispose flushing water without damage to adjacent properties. Flushing velocities shall be at least 2.5 fps.

(c) All mains shall be cleaned using a poly-pig cleaning system as detailed in Chapter II, Section J.9. All equipment and piping shall be provided by the contractor. Testing shall be conducted to ensure proper cleanliness of the pipe as detailed in this section. PSLUSD will not accept any utility mains that do not pass the cleanliness test.

(d) Prior to the actual line flushing operation, the contractor shall properly notify the PSLUSD and EOR of such intended water use a minimum of 48 hours prior to flushing of mains up to 8" diameter, and at least 1 week prior to flushing of mains larger than 8". All flushing times will be limited to off peak times of water system demand and consumption. No flushing shall take place without the PSLUSD inspector and EOR being present.

(e) The contractor shall pay the PSLUSD for all water used.

(f) The flushing report shall be submitted by the EOR on PSLUSD form prior to disinfection.

(6) Hydrostatic and Leakage Testing

(a) Hydrostatic and leakage tests shall be made between valves and/or connectors for each section tested using the procedure outlined in ANSI/AWWA C600 for DIP and C605 for PVC.

(b) The contractor shall provide all necessary equipment such as pumps, gauges and water measuring tanks and shall perform all work required for pipe pressure and leakage test. The gauge shall read in 2 pound increments.

(c) Hydrostatic testing shall be performed for a period of not less than two hours at 150 psi pressure for water/force/reclaimed water mains and at 100 psi for low-pressure mains. The allowable rate of leakage shall be less than the number of gallons per hour determined by the following formula:

L = (SD * sqrt(P)) / 148,000

- L = Allowable leakage in gallons per hour.
S = Length of pipe tested in feet.
D = Nominal diameter of the pipe in inches.
P = Average test pressure maintained during the test in pounds per square inch gauge.

(d) The testing procedure shall include the continued application of the specified pressure to the test system for the two-hour period using a suitable pump connected to the pipeline. The pipeline shall be allowed to stabilize at the test pressure before conducting the hydrostatic test. The pressure shall not vary by more than +5 psi from the required pressure for the duration of the test. Test pressure shall be maintained with this tolerance by adding makeup water through the pump into the pipeline. The amount of makeup water shall be accurately measured and shall not exceed the allowable leakage rate (L) as determined using the above formula. If at any point during the test the pressure loss exceeds 5 psi, the test is considered failed. Should the test fail, the contractor shall make necessary repairs and the test shall be repeated until satisfactory results are obtained.

(e) Any exposed pipe, fittings, valves, hydrants, and joints shall be examined during the test to ensure there are no visible leaks. Any damaged or defective pipe fittings, valves, or hydrants that are discovered following the pressure test shall be repaired or replaced with sound material, and the test shall be repeated.

(f) The pressure test report shall be submitted by the EOR on PSLUSD form prior to disinfection.

CAPTEC Engineering, Inc. logo and contact information: 301 NW Flagler Ave, Stuart, FL 34994, Phone: (772) 892-4344, Fax: (772) 892-4341, Engineering Business No. EB-007857

Table with project details: DATE: 8-24-22, DRAWN BY: MDB, DESIGNED BY: MDB, CHECKED BY: JWC, PROJECT NO.: 2032, HORZ. SCALE: N/A, VERT. SCALE: N/A, CAD FILE:

Table with revision history: NO., DATE, BY, REVISIONS

SCALE VERIFICATION: 0 0.5 1.0. SOLID BAR IS EQUAL TO HALF AN INCH ON ADJUST ALL SCALED DIMENSIONS ACCORDINGLY.

TOM MACKIE BLVD. EXTENSION CITY OF PORT ST. LUCIE, FLORIDA PSLUSD GENERAL NOTES

Joseph W. Capra 301 N.W. Flagler Ave. Stuart, Florida 34994 P.E. No. 37638

Printed Date:

PSLUSD # 11-900-23

JOB No.: 2032 SHEET 33 OF 34

PSL # P24-010

THIS DOCUMENT, TOGETHER WITH THE CONCEPTS AND DESIGNS PRESENTED HEREIN, AS AN INSTRUMENT OF SERVICE, IS INTENDED ONLY FOR THE SPECIFIC PURPOSE AND CLIENT FOR WHICH IT WAS PREPARED. REUSE OF AND IMPROPER RELIANCE ON THIS DOCUMENT WITHOUT WRITTEN AUTHORIZATION AND ADOPTION BY CAPTEC ENGINEERING, INC. SHALL BE WITHOUT LIABILITY TO CAPTEC ENGINEERING, INC.

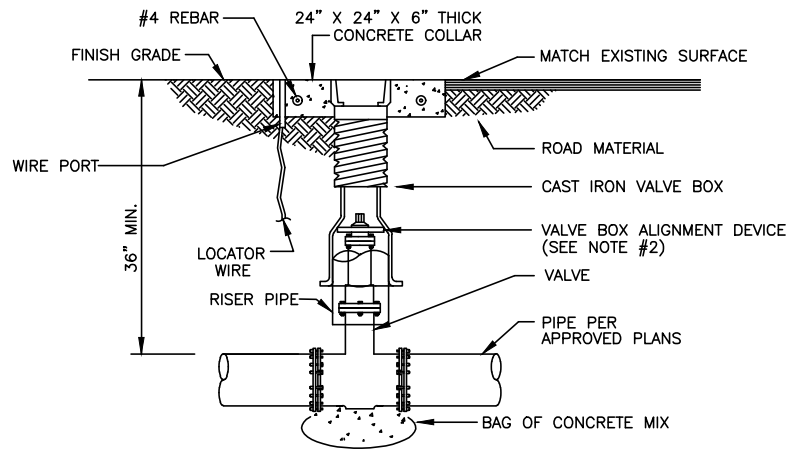

NOTES:

1. WHEN TOP OF OPERATING NUT IS DEEPER THAN 30", A HIGH STRENGTH STEEL EXTENSION WILL BE REQUIRED TO BRING OPERATING NUT 24"-30" BELOW FINISHED GRADE. A STEEL CENTERING PLATE, WELDED TO THE EXTENSION, IS ALSO REQUIRED.
2. A VALVE BOX ALIGNMENT DEVICE SHALL BE PROVIDED TO ELIMINATE SHIFTING OF THE VALVE BOX AGAINST THE OPERATING NUT.
3. BOLT DOWN COVER SHALL BE USED IN ALL AREAS.
4. C900 P.V.C. RISER PIPE SHALL BE ADDED TO EXTEND THE VALVE BOX IF NEEDED.
5. RPM'S SHALL NOT BE INSTALLED IN CROSSWALKS OR PEDESTRIAN WALKWAYS.
6. THE TOP SIDE OF THE VALVE BOX COVER AND THE INSIDE OF TOP SECTION OF THE VALVE BOX SHALL BE PAINTED BLUE FOR WATER MAINS, GREEN FOR SEWER MAINS AND PURPLE FOR RECLAIMED WATER MAINS.

TYPICAL VALVE BOX AND COLLAR G-07

SCALE: N.T.S.
DATE: 2019

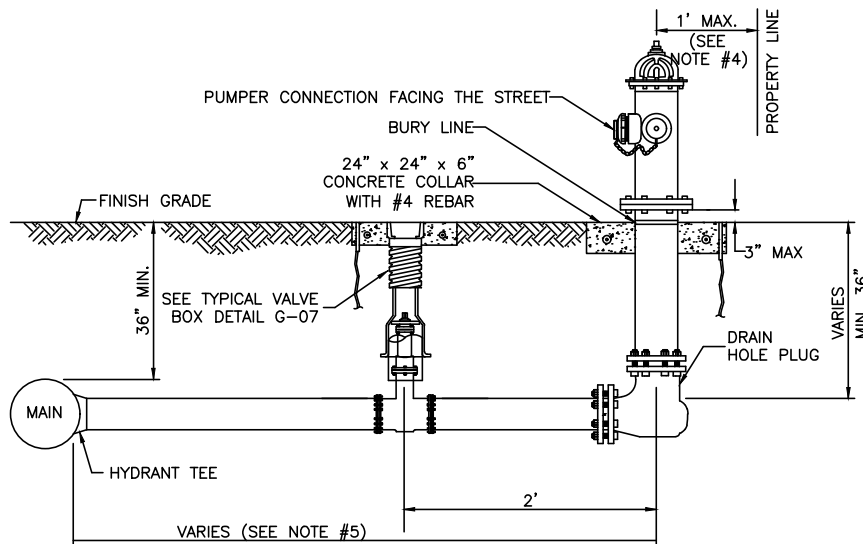

NOTES:

1. HYDRANTS SHALL BE INSTALLED IN ACCORDANCE WITH ANSI/AWWA C600. THE HYDRANTS SHALL BE PAINTED BY THE MANUFACTURER WITH 2 COATS (MIN.).
2. VERTICAL BENDS MAY BE NECESSARY TO OBTAIN COVER UNDER SWALES OR AT HYDRANT LOCATION. VERTICAL BENDS OR OFFSETS ARE INCLUDED IN HYDRANT ASSEMBLY. ALL BENDS MUST BE RESTRAINED.
3. CONNECTOR PIPE AND ANY REQUIRED VERTICAL BENDS SHALL HAVE AN ANCHORING FEATURE ON BOTH ENDS SO THAT WHEN USED WITH M.J. SPLIT GLANDS, A RESTRAINED JOINT IS PROVIDED.
4. WHEN INSTALLED WITH SIDEWALK OR CURB, PROVIDE MIN. 2 FOOT CLEARANCE TO ANY PORTION OF THE HYDRANT, UTILIZING THE SIDE LOT EASEMENT IF NECESSARY.
5. A GATE VALVE SHALL BE INSTALLED WITHIN 2 FEET OF THE FIRE HYDRANT. IF DISTANCE FROM THE WATER MAIN TO THE FIRE HYDRANT IS GREATER THAN 20 FEET, A SECOND GATE VALVE SHALL BE INSTALLED WITHIN 2 FEET OF THE MAIN.
6. ANY DEVIATIONS FROM THE CRITERIA ABOVE REQUIRE A WRITTEN RECOMMENDATION FROM THE ENGINEER-OF-RECORD AND WRITTEN APPROVAL BY PSLUSD.

FIRE HYDRANT ASSEMBLY W-06

SCALE: N.T.S.
DATE: 2019

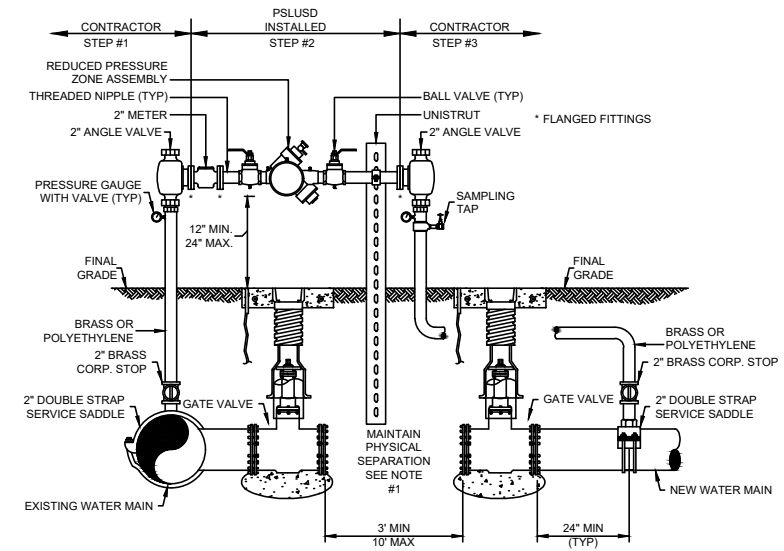
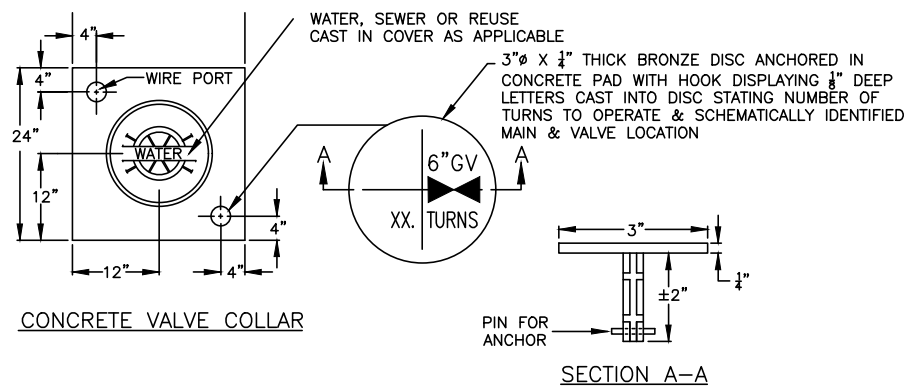

FOR 2" JUMPER CONNECTIONS UP TO 8" PIPE

NOTE:
FOR 12" DR-18 PIPE @ 2.5' PER/SEC, 831 GPM, WILL REQUIRE 4" TO 6" METER ASSEMBLY

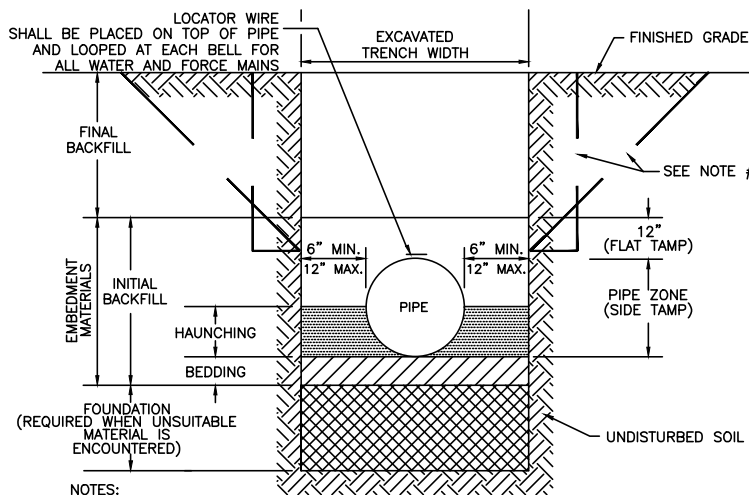

NOTES:

1. FOR TRENCHES REQUIRING SHEETING, SHORING, STAY BRACING, TRENCH JACKS OR TRENCH BOX, DIMENSIONS SHALL BE TAKEN FROM THE INSIDE FACE OF THE SUPPORTS.
2. IF THE MAXIMUM TRENCH WIDTH MUST BE EXCEEDED, THE AREA OUTSIDE OF THE MAXIMUM EMBEDMENT SHALL BE COMPACTED TO FINAL BACKFILL REQUIREMENTS. IF THE PIPE IS INSTALLED IN A COMPACTED EMBANKMENT, THE EMBANKMENT SHALL BE IN PLACE AND COMPACTED TO 12" MIN. COVER BEFORE INSTALLATION OF PIPE.
3. IF BEDDING IS REQUIRED TO BRING TRENCH BOTTOM UP TO GRADE AND PROVIDE UNIFORM AND ADEQUATE LONGITUDINAL SUPPORT UNDER THE PIPE, THEN A MINIMUM COMPACTED DEPTH OF 4 TO 6 INCHES OF SELECT EMBEDMENT MATERIAL IS REQUIRED.
4. THE CONTRACTOR SHALL COMPLY WITH REQUIREMENTS OF THE FLORIDA TRENCH SAFETY ACT.
5. AN APPROVED LOCATOR WIRE SHALL BE USED.
6. EARTHWORK, EXCAVATION, BACKFILL AND COMPACTION SHALL BE IN ACCORDANCE WITH PSLUSD STANDARDS.

STANDARD PIPE TRENCH CROSS SECTION G-04

SCALE: N.T.S.
DATE: 2019

MINIMUM SEPARATION BETWEEN PSLUSD FACILITIES AND OTHER UTILITIES			
OTHER PIPE	HORIZONTAL SEPARATION	CROSSINGS (1)	JOINT SPACING @ CROSSINGS (FULL JOINT CENTERED)
GRAVITY OR PRESSURE SANITARY SEWER, SANITARY SEWER FORCE MAIN, RECLAIMED WATER (2), (3), VACUUM SANITARY SERVICE, STORM SEWER, STORM SEWER FORCE MAIN	WATER MAIN 10' MINIMUM	WATER MAIN 18" MINIMUM	WATER MAIN 6" MINIMUM
ALL OTHER FACILITIES, INCLUDING BUT NOT LIMITED TO: TELEPHONE, CABLE TV, POWER, ETC.	PSLUSD FACILITY (4) 5' MINIMUM	PSLUSD FACILITY (4) 18" MINIMUM	WATER MAIN 3" MINIMUM
ON-SITE SEWAGE TREATMENT AND DISPOSAL SYSTEM	10' MINIMUM	-----	-----

(1) WATER MAIN SHOULD CROSS OVER OTHER PIPE. WHEN WATER MAIN MUST BE BELOW OTHER PIPE, THE MINIMUM SEPARATION IS 18".
(2) RECLAIMED WATER REGULATED UNDER PART III OF CHAPTER 62-610, F.A.C.
(3) RECLAIMED WATER NOT REGULATED UNDER PART III OF CHAPTER 62-610, F.A.C.
(4) A PSLUSD FACILITY INCLUDES MAINS AND STRUCTURES FOR POTABLE WATER, WASTEWATER AND RECLAIMED WATER.

STANDARD SEPARATION REQUIREMENTS G-01

SCALE: N.T.S.
DATE: 2019

PSLUSD # 11-900-23

301 N.W. Flagler Ave.
Stuart, Florida 34994
Phone: (772) 892-4344
Fax: (772) 892-4341

CAPTEC
Engineering, Inc.
Civil Engineering Professionals

Engineering Business
No. EB-007857

DATE: 8-24-22

DRAWN BY:	MDB
DESIGNED BY:	MDB
CHECKED BY:	JWC
PROJECT NO.:	2032
HORIZ. SCALE:	N/A
VERT. SCALE:	N/A
CADD FILE:	

NO.	DATE	BY	REVISIONS
1.	08-14-24	MDB	BID SET

SCALE VERIFICATION

0 0.5 1

SOLID BAR IS EQUAL TO HALF AN INCH ON DRAWING. ADJUST ALL SCALED DIMENSIONS ACCORDINGLY

TOM MACKIE BLVD. EXTENSION
CITY OF PORT ST. LUCIE, FLORIDA

UTILITY DETAILS

Joseph W. Capra
301 N.W. Flagler Ave.
Stuart, Florida 34994
P.E. No. 37638

Printed Date:

JOB No.: 2032
SHEET 34 OF 34

PSL # P24-010

P:\2000\2032 - PSL Hegener Drive Phase 3\DWG\2032 Gen Notes.dwg, 5/17/2024 11:34:40 AM