

**MEDIAN 1**

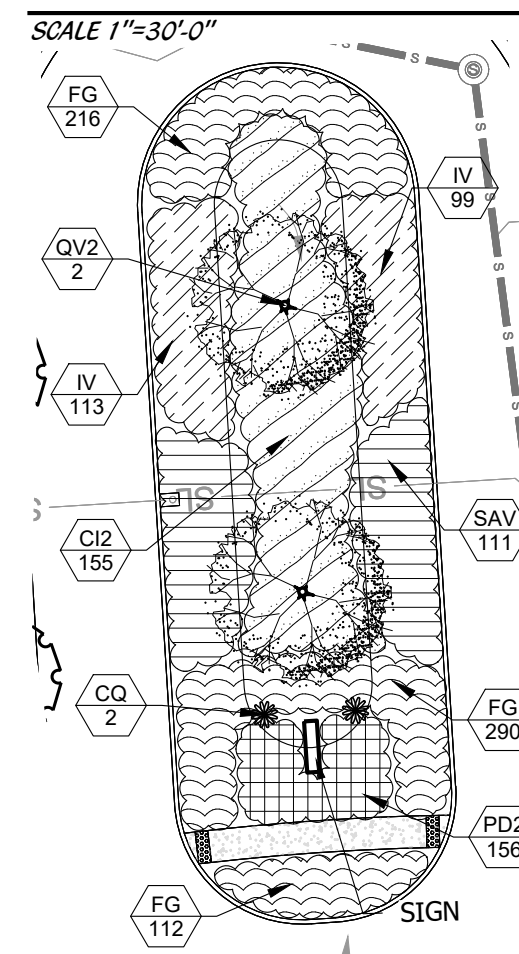

**CUL-DE-SAC 1**

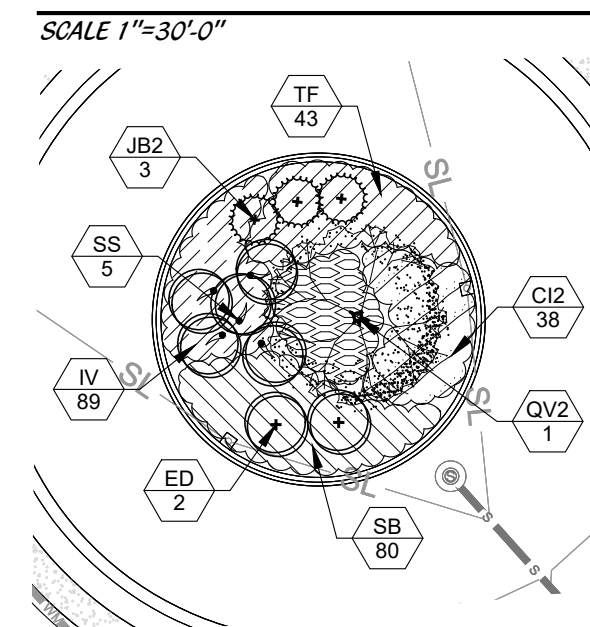

**COMMON AREA 5**

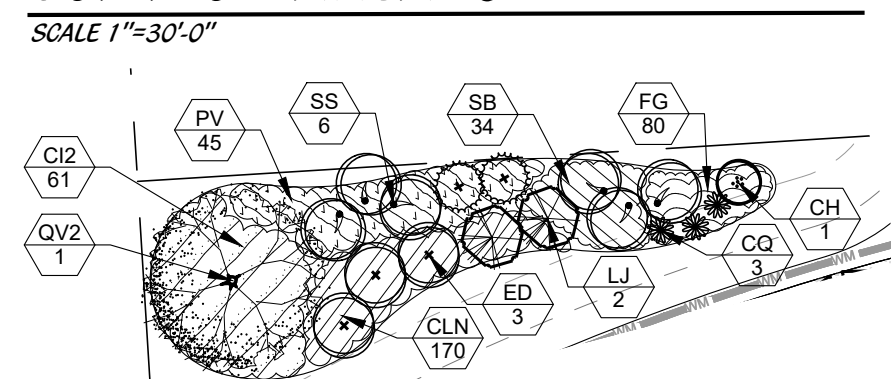

**COMMON AREA 6**

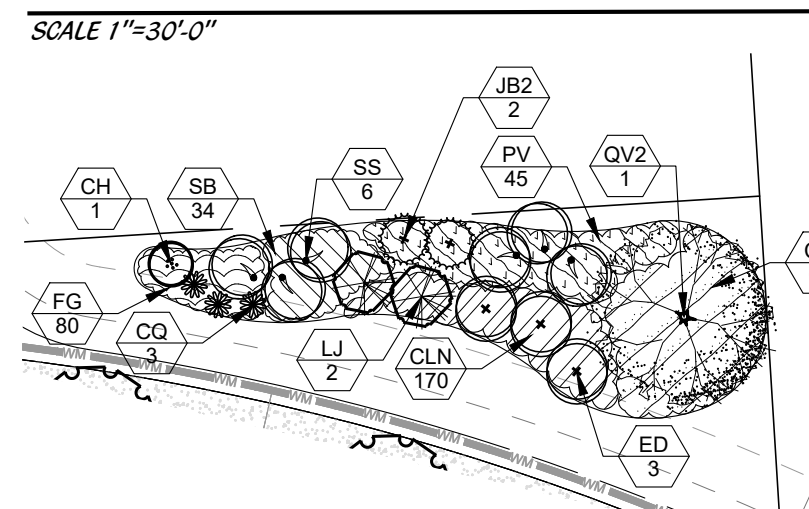

**COMMON AREA 8**

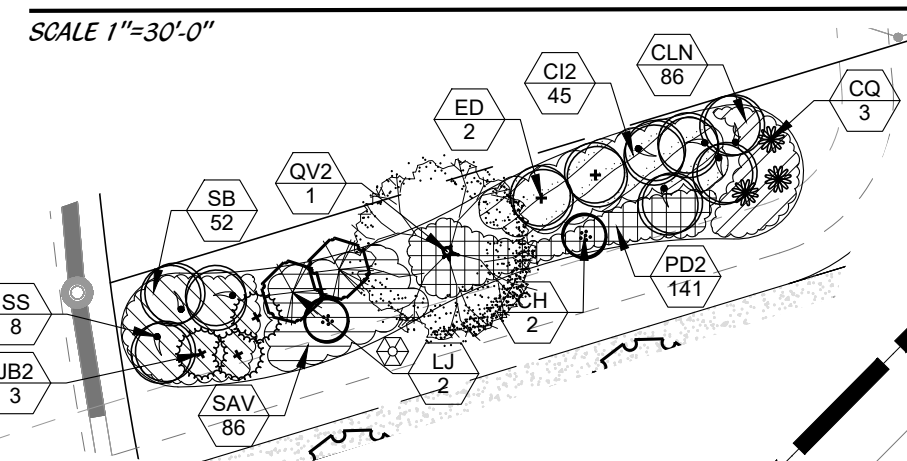

**COMMON AREA 9**

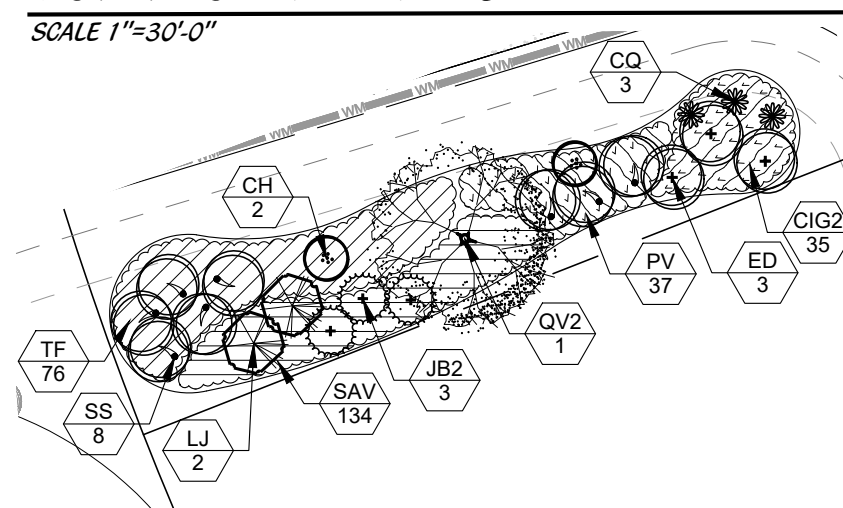

**KEY MAP**

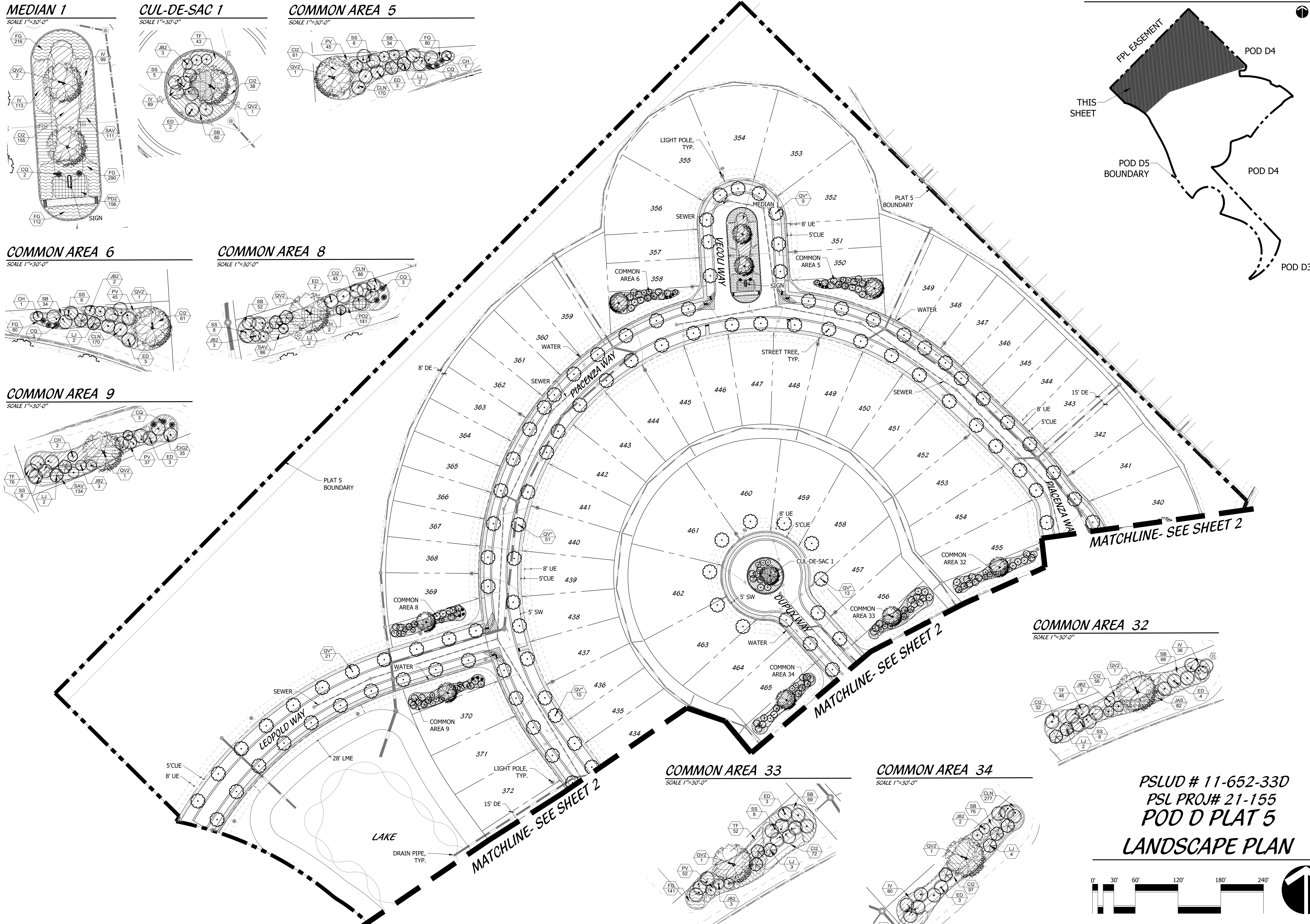
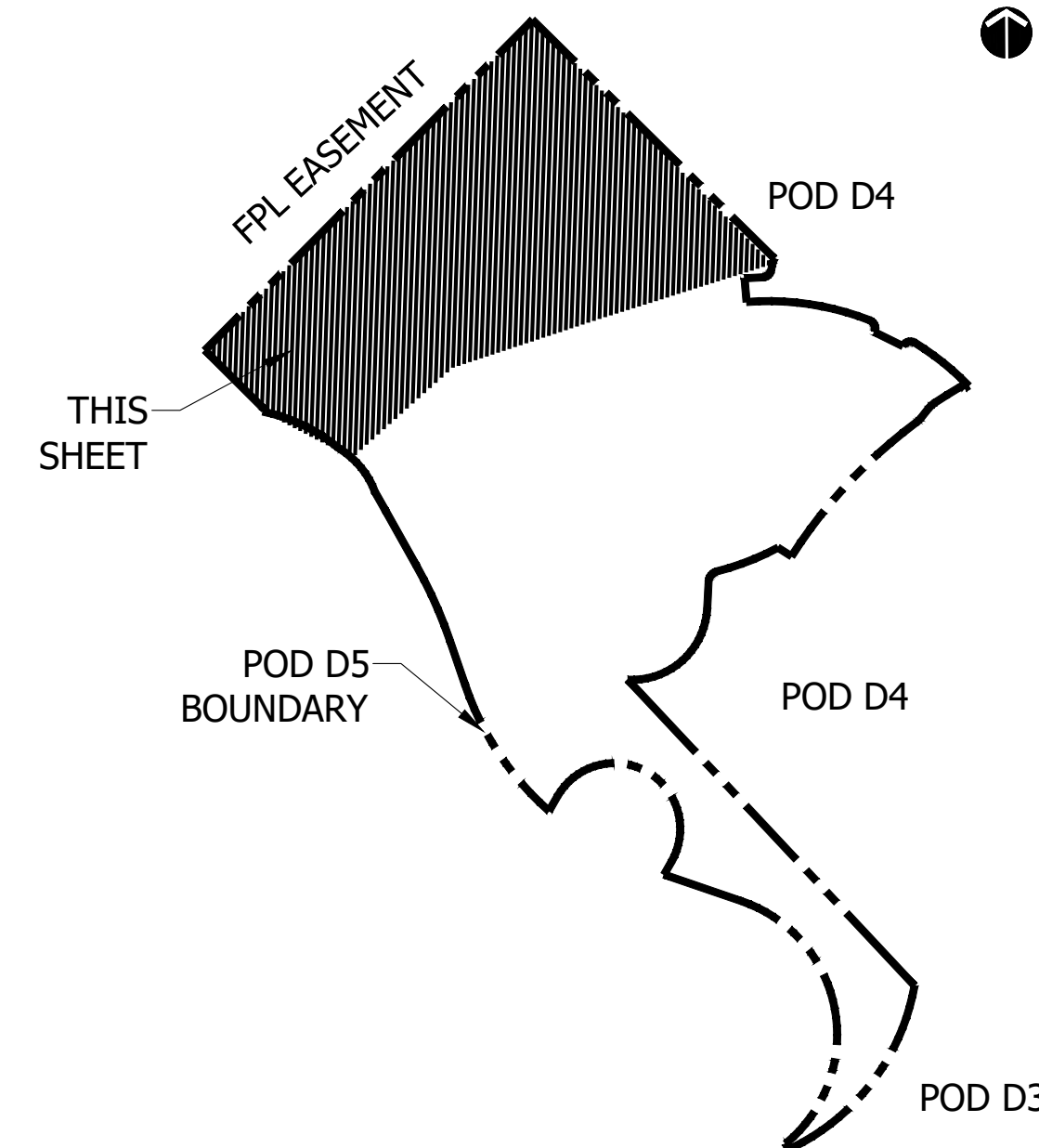

**COMMON AREA 32**

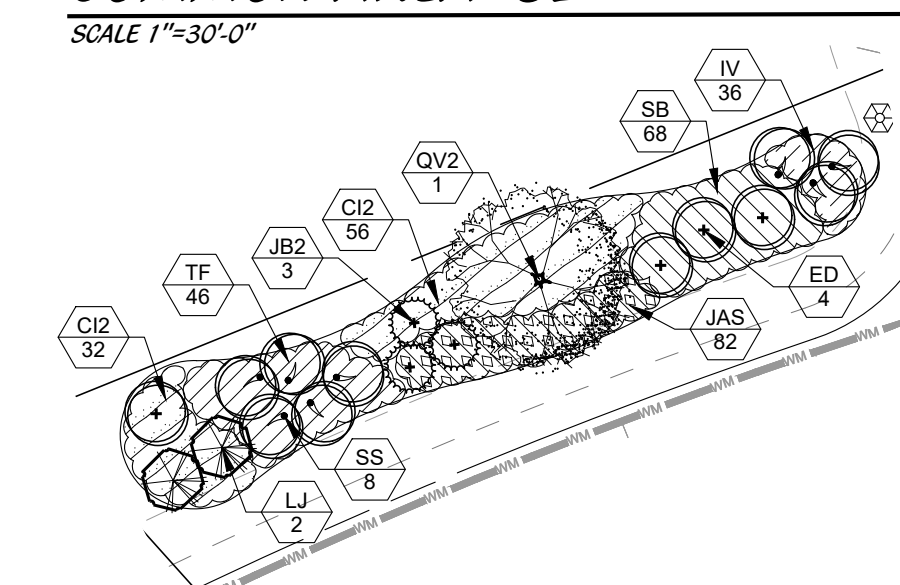

**COMMON AREA 33**

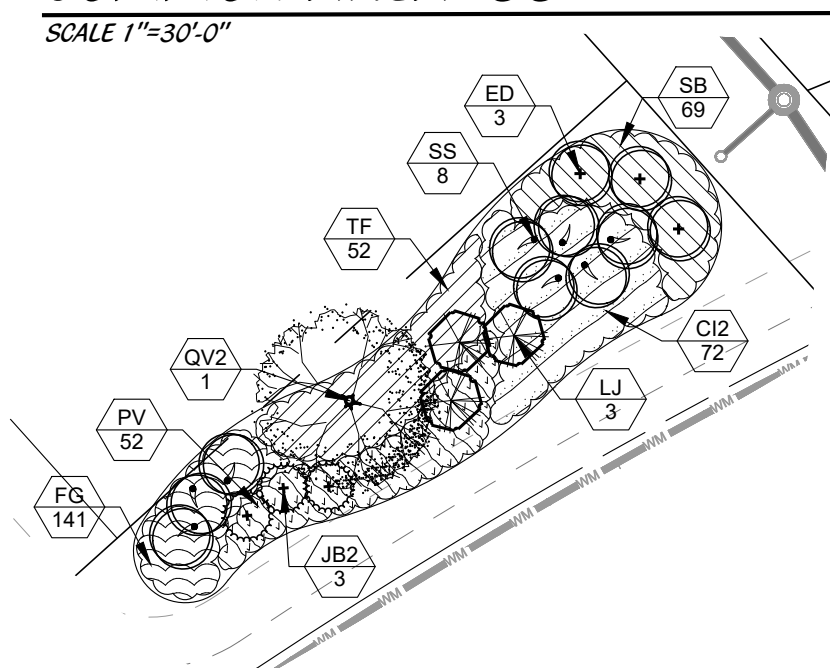

**COMMON AREA 34**

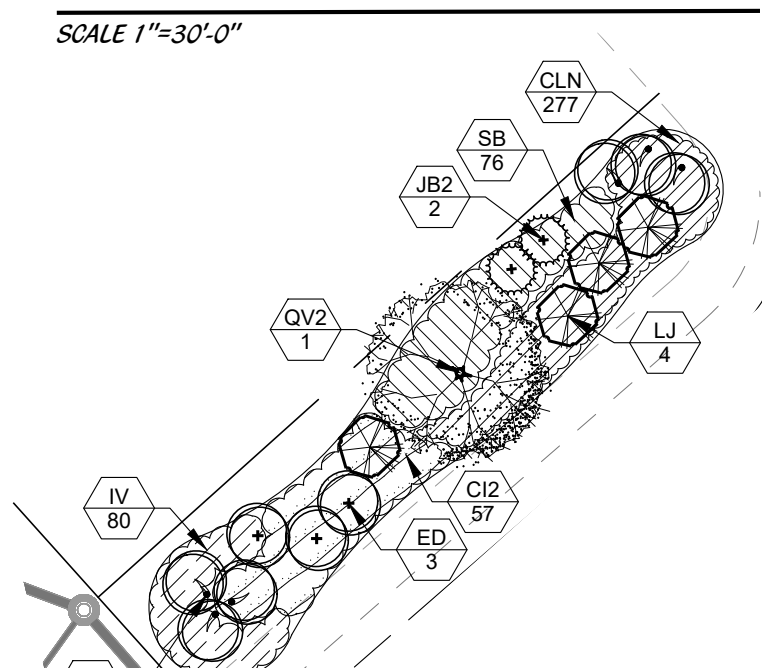

PSLUD # 11-652-33D  
PSL PROJ# 21-155  
POD D PLAT 5  
**LANDSCAPE PLAN**

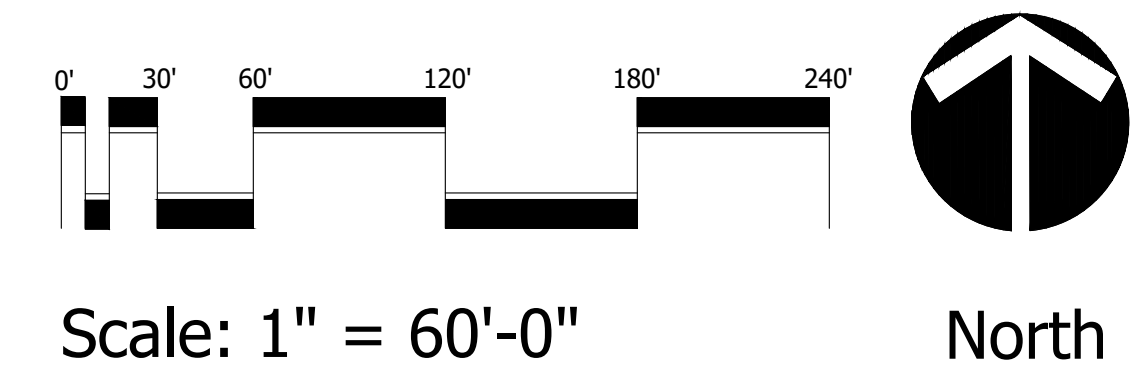



**Cotleur & Hearing**  
Landscape Architects  
Land Planners  
Environmental Consultants  
1934 Commerce Lane  
Suite 1  
Jupiter, Florida 33458  
561.747.6336 · Fax 747.1377  
www.cotleurhearing.com  
Lic# LC-C000239

**VERANO SOUTH**  
Kolter Homes  
Port St. Lucie, Florida

DESIGNED	DTS
DRAWN	LAH
DATE	07-21-21
REVISIONS	09-10-21

**COMMON AREA 11**

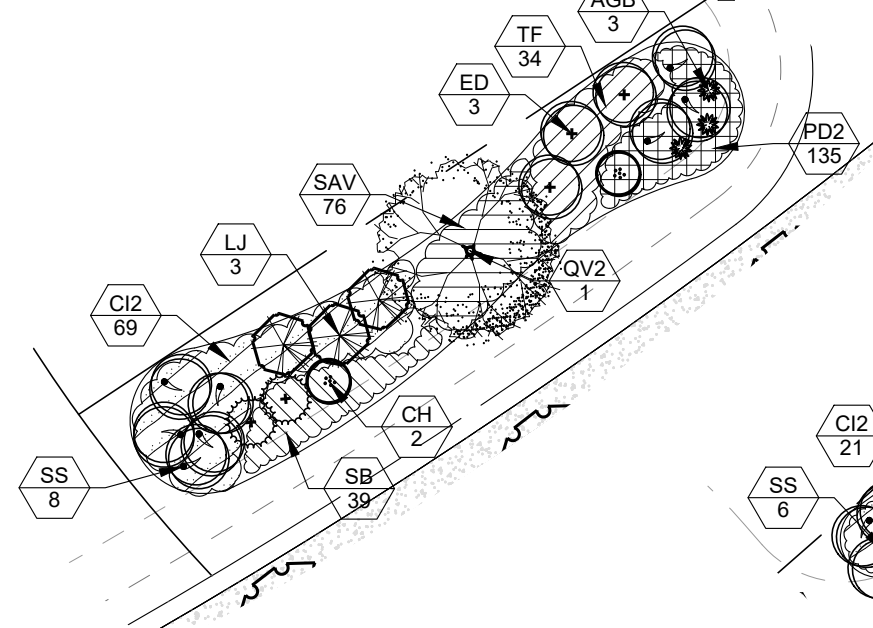
SCALE 1"=30'-0"



**COMMON AREA 35**

SCALE 1"=30'-0"

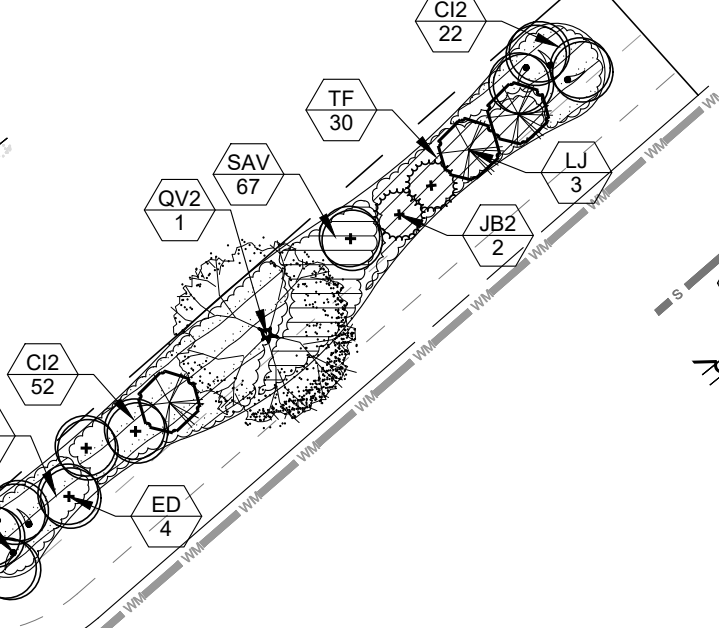

**COMMON AREA 27**

SCALE 1"=30'-0"

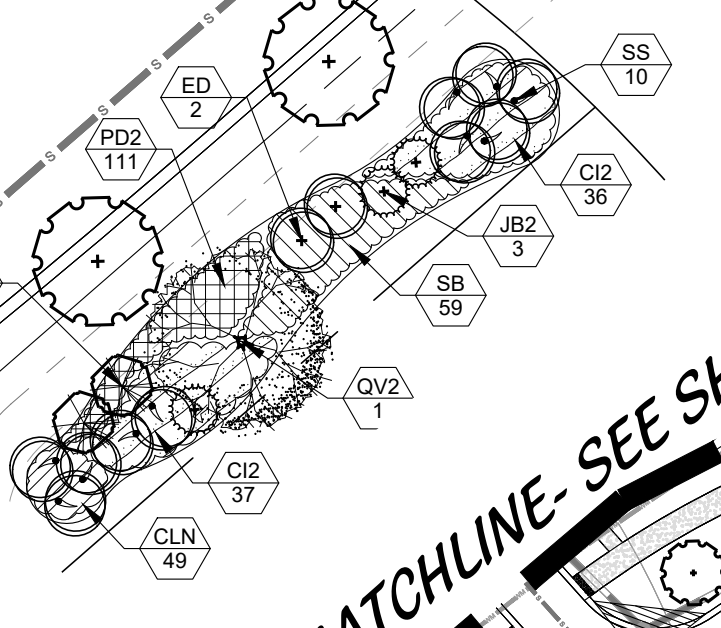

**COMMON AREA 2**

SCALE 1"=30'-0"

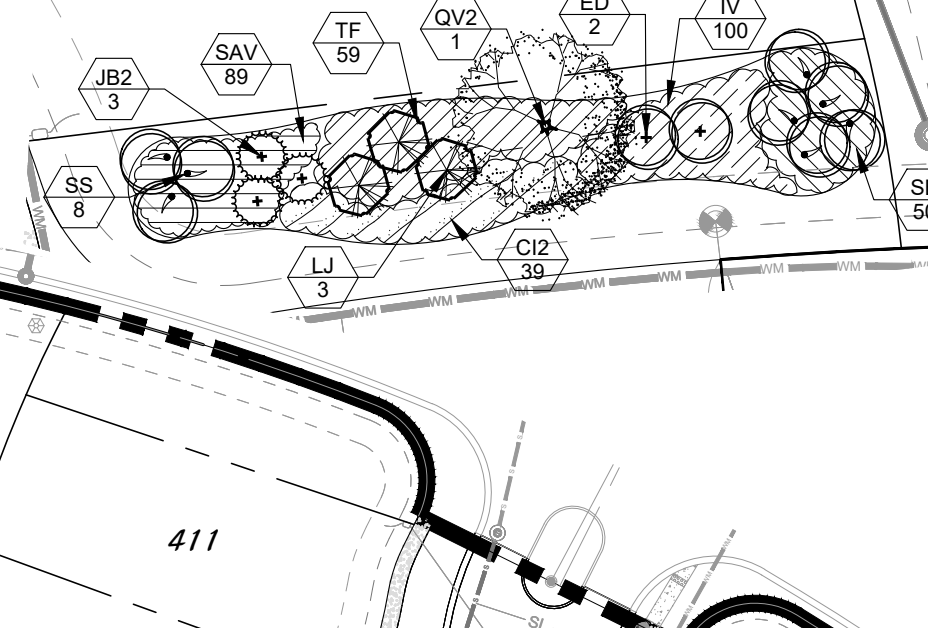

**MEDIAN 4**

SCALE 1"=30'-0"

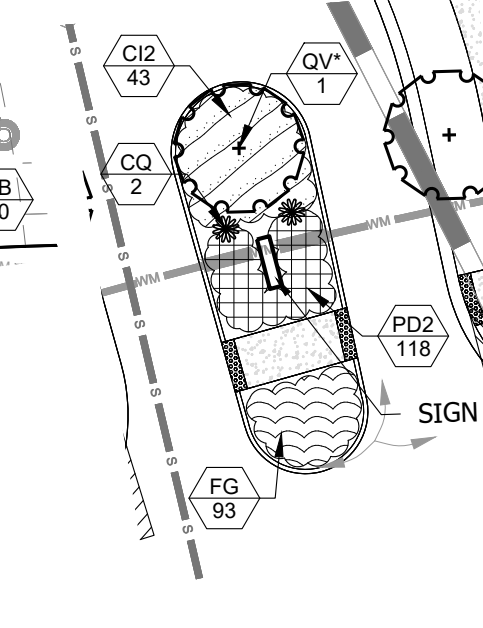

**COMMON AREA 15**

SCALE 1"=30'-0"

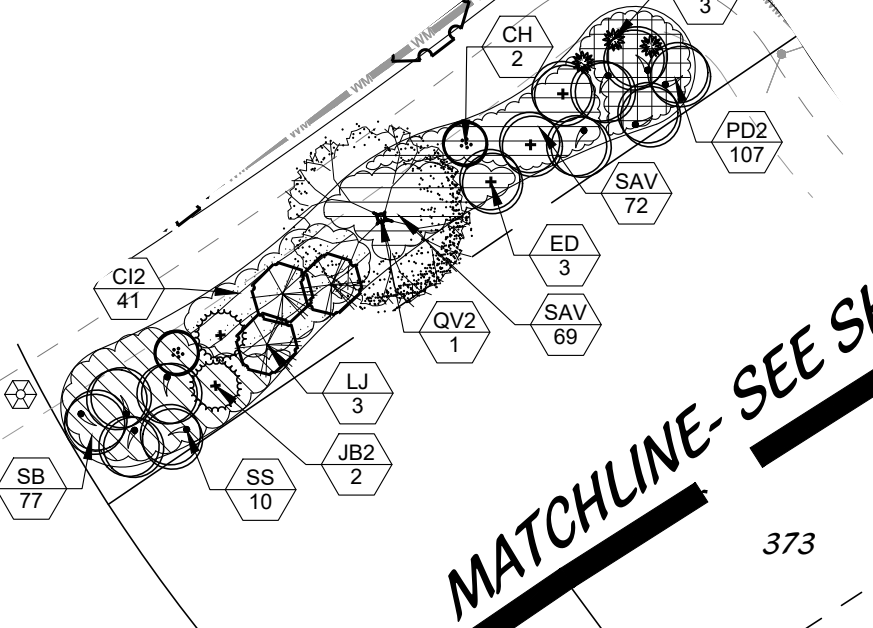

MATCHLINE- SEE SHEET 1

MATCHLINE- SEE SHEET 1

**MEDIAN 2**

SCALE 1"=30'-0"

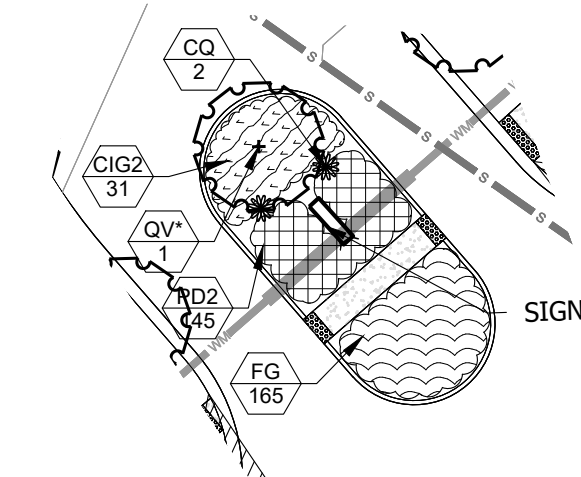

**MEDIAN 3**

SCALE 1"=30'-0"

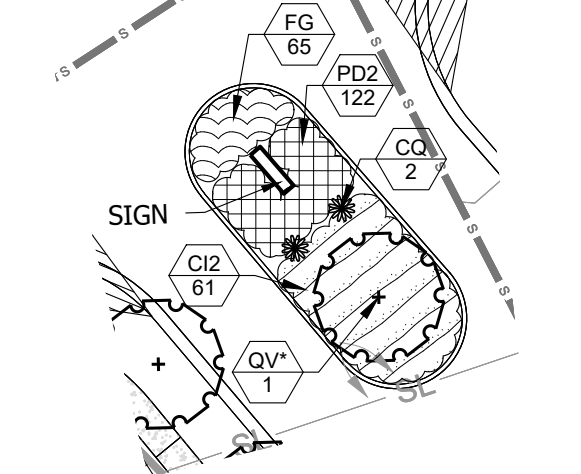

**COMMON AREA 16**

SCALE 1"=30'-0"

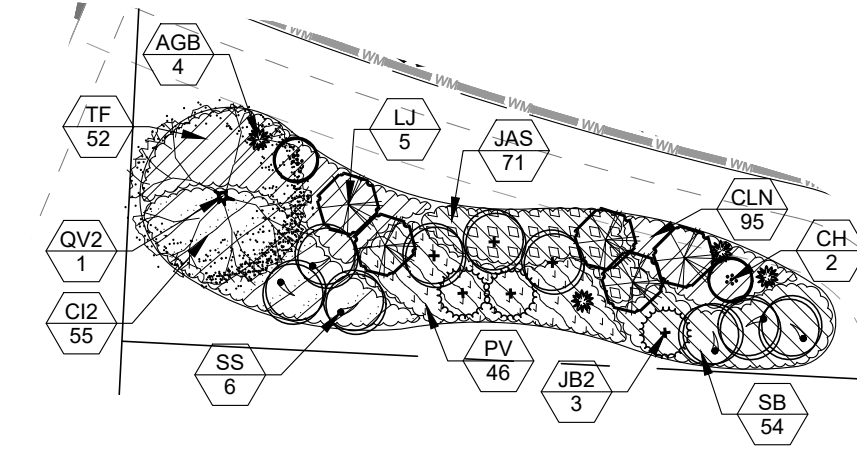

**COMMON AREA 19**

SCALE 1"=30'-0"

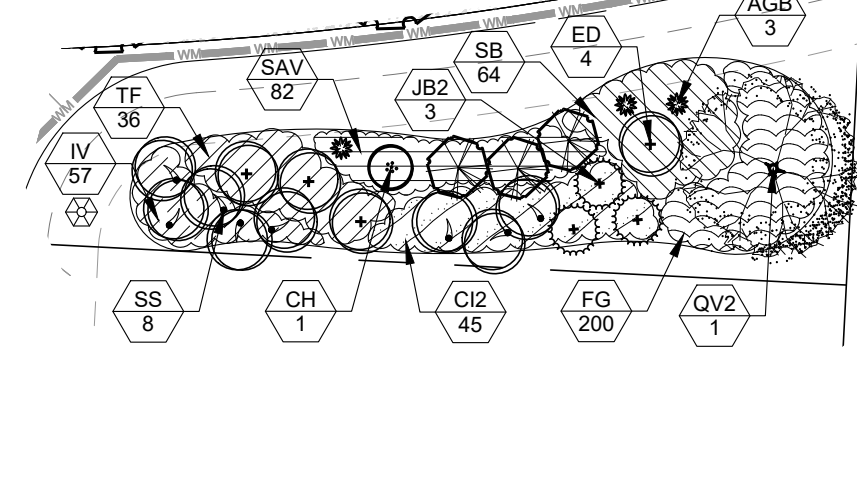

**MEDIAN 5**

SCALE 1"=30'-0"

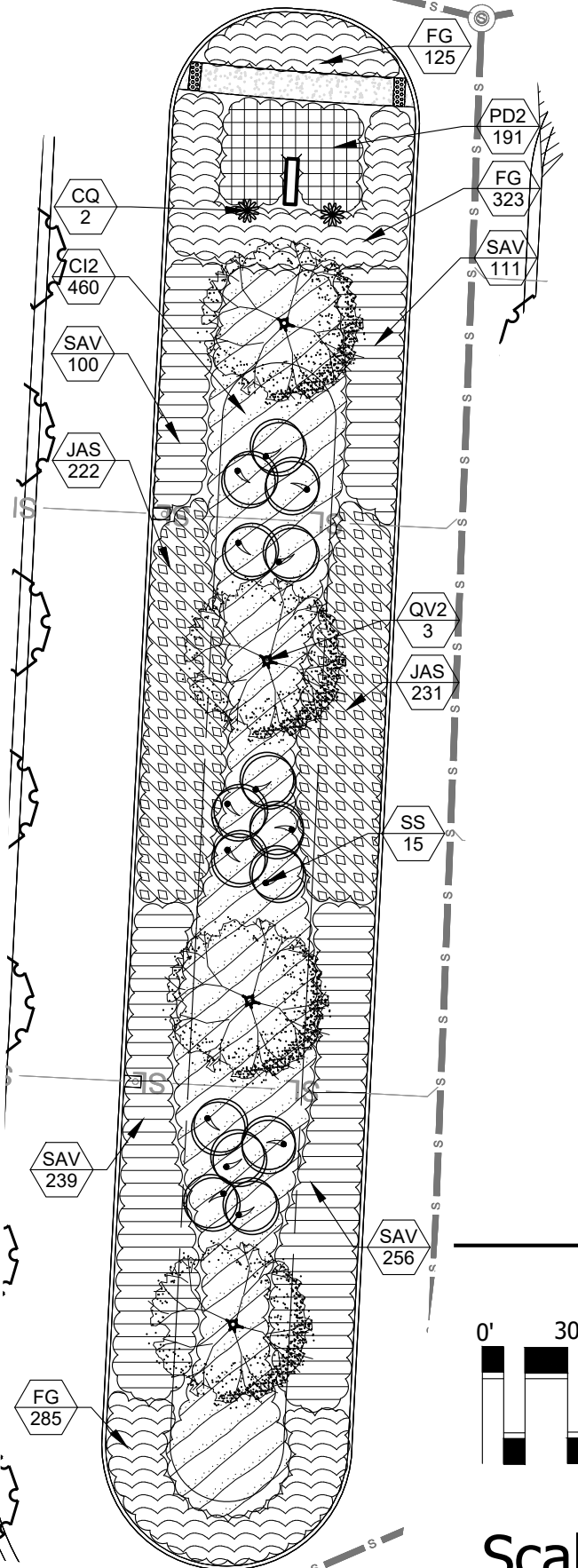

**KEY MAP**



PSLUD # 11-652-33D  
PSL PROJ# 21-155  
POD D PLAT 5  
**LANDSCAPE PLAN**

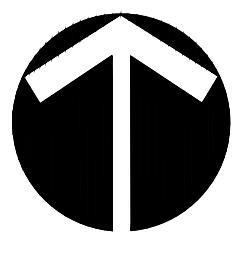
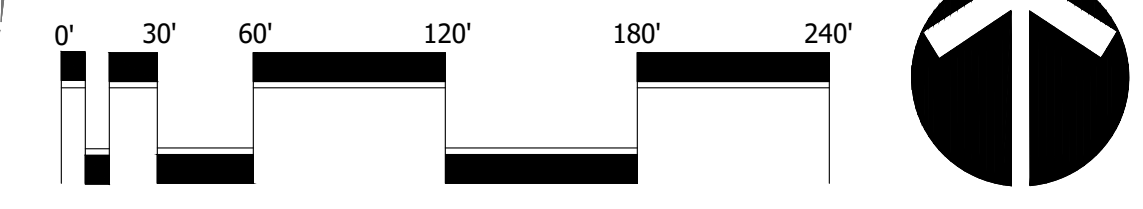

MATCHLINE- SEE SHEET 3

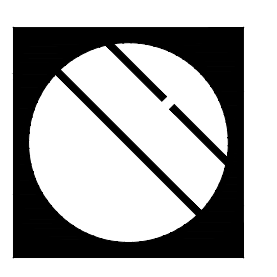

**Cotleur & Hearing**

Landscape Architects  
Land Planners  
Environmental Consultants  
1934 Commerce Lane  
Suite 1  
Jupiter, Florida 33458  
561.747.6336 · Fax 747.1377  
www.cotleurhearing.com  
Lic# LC-C000239

**VERANO SOUTH**  
Kolter Homes  
Port St. Lucie, Florida

DESIGNED	DTS
DRAWN	LAH
DATE	07-21-21
REVISIONS	09-10-21

© COTLEUR & HEARING, INC.  
These drawings are the property of the architect and are not to be used for alterations or on other projects except by agreement in writing with the architect. Immediately report any discrepancies to the architect.

MATCHLINE- SEE SHEET 2

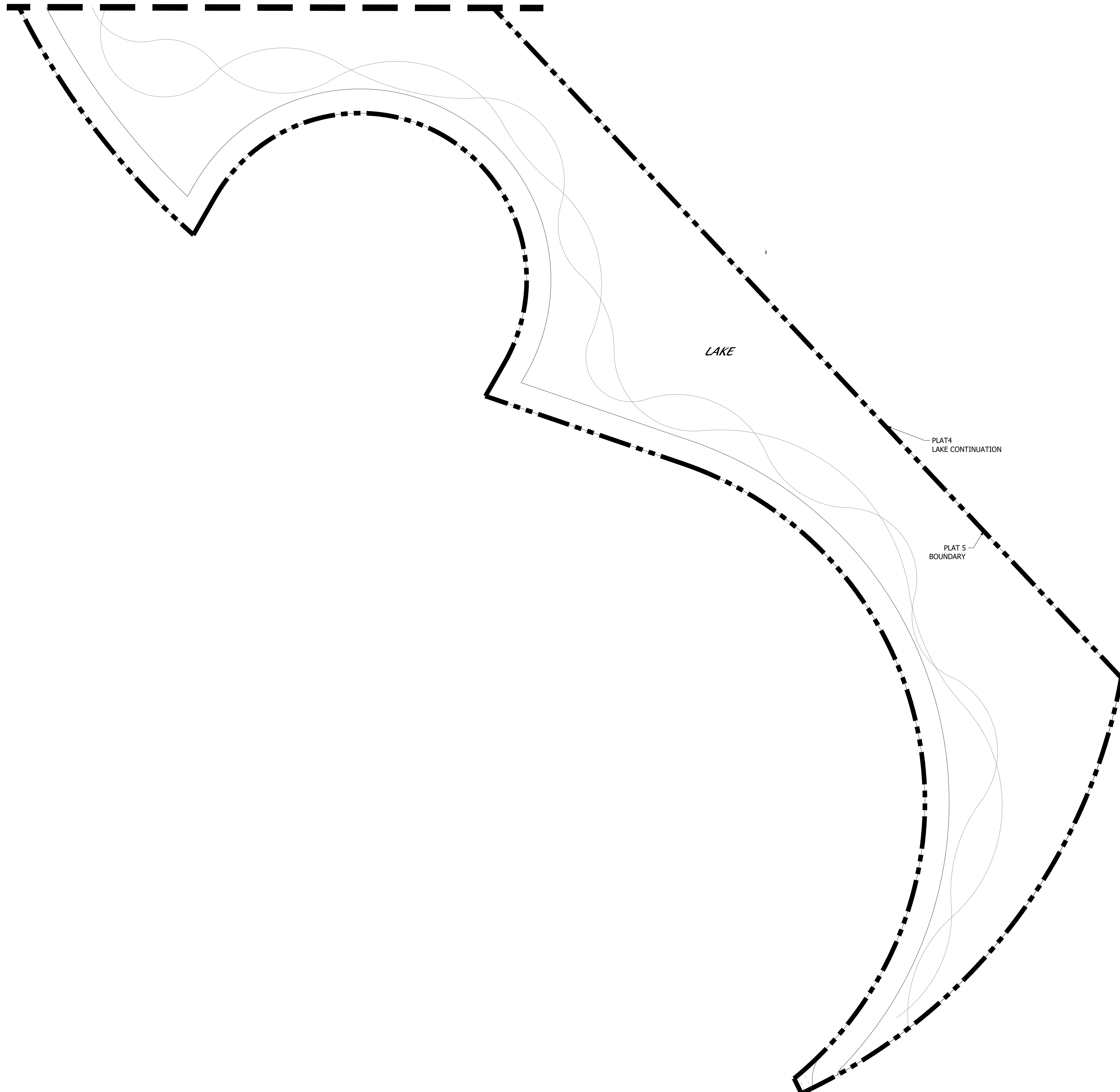

KEY MAP

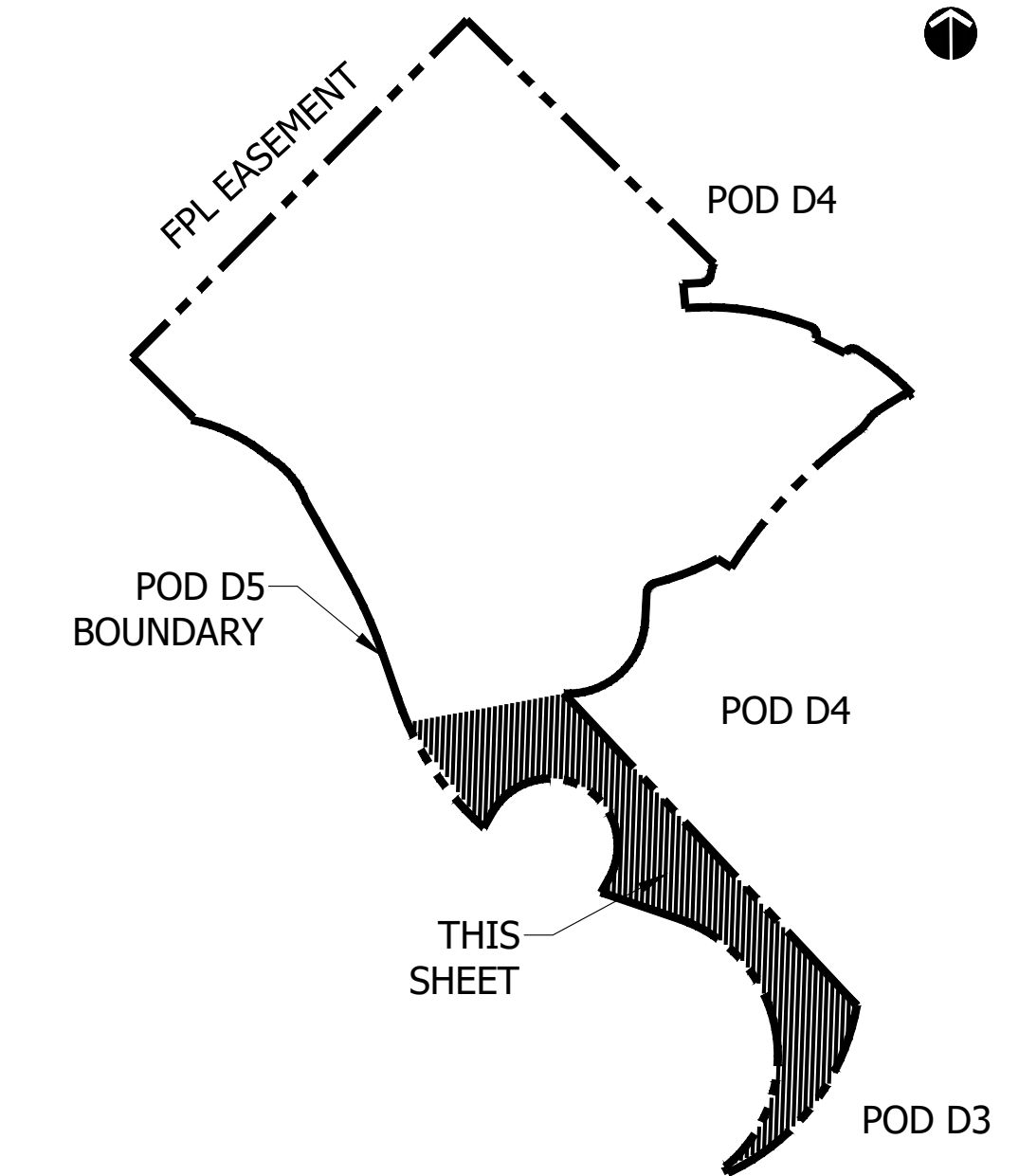

TYPICAL DRIVEWAY LAYOUTS

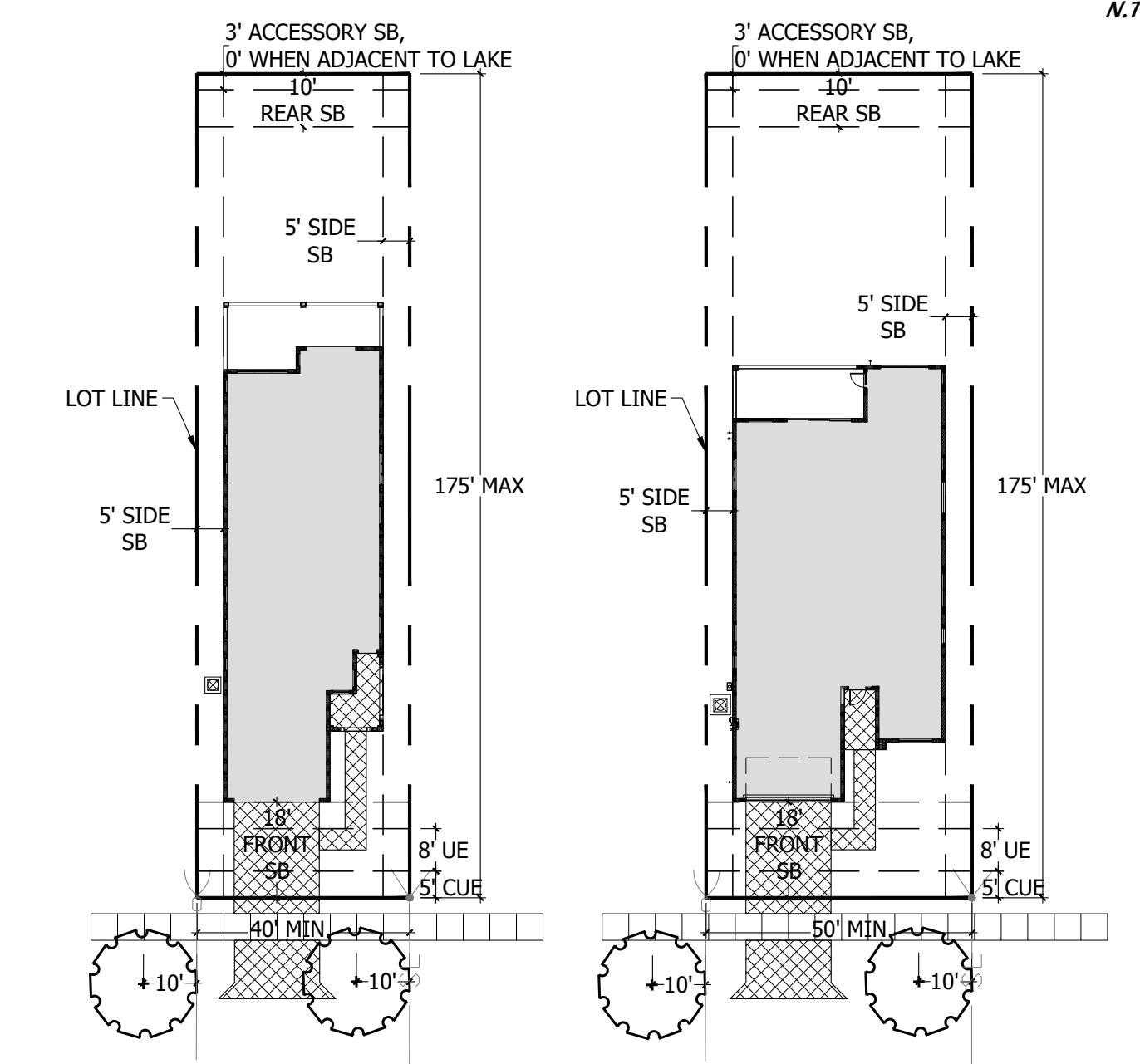

PSLUD # 11-652-33D  
 PSL PROJ# 21-155  
 POD D PLAT 5  
 LANDSCAPE PLAN

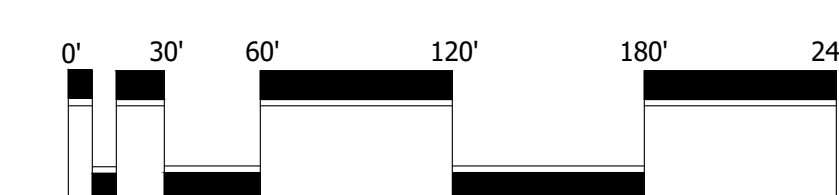

Scale: 1" = 60'-0"

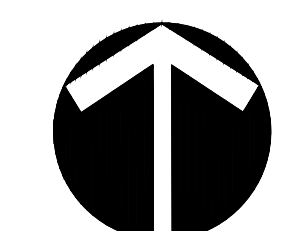

North

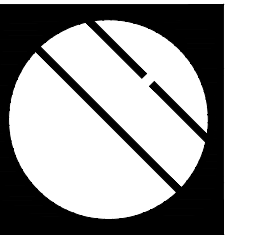

**Cotleur & Hearing**  
 Landscape Architects  
 Land Planners  
 Environmental Consultants

1934 Commerce Lane  
 Suite 1  
 Jupiter, Florida 33458  
 561.747.6336 · Fax 747.1377  
 www.cotleurhearing.com  
 Lic# LC-C000239

**VERANO SOUTH**  
 Kolter Homes  
 Port St. Lucie, Florida

DESIGNED	DTS
DRAWN	LAH
DATE	07-21-21
REVISIONS	09-10-21

SHEET 3 OF 4

© COTLEUR & HEARING, INC.  
 These drawings are the property of the architect and are not to be used for other projects except by agreement in writing with the architect. Immediately report any discrepancies to the architect.

