



"A City for All Ages"

**City of Port St. Lucie
Electronic Bid ("eBid")**

**Event Name: Remove & Replace 8,000 Gallon Diesel Fuel Tank @ Southport Booster Station
eBid (Event) Number: 20220028**

1. Introduction

1.1. Purpose of Procurement

Pursuant to the [City of Port St. Lucie Code of Ordinances, Sec. 35.05](#), this electronic ("eBid") is being issued to establish a contract with one or more qualified Contractors who will furnish all labors, equipment, and materials to remove and replace existing 8,000 gallon above ground diesel fuel tank at Southport Booster Station to the City of Port St. Lucie (hereinafter, "City") as further described in this eBid.

A descriptive overview of the City of Port St. Lucie can be found at <https://www.cityofpsl.com/discover-us/about-psl> . Please visit the City's website to familiarize yourself with how our city is structured and operates. Please contact the Issuing Officer with any questions.

1.2. Restrictions on Communicating with Staff

From the issue date of this eBid until a City generated Purchase Order is submitted to the contracted contractor (or the eBid is officially cancelled), contractors are not allowed to communicate for any reason with any City staff or elected officials except through the Issuing Officer named herein, or during the Bidders/Offerors' conference (if any), or as defined in this eBid or as provided by existing work agreement(s). This is commonly known as a cone of silence during the procurement process as identified in the [City Code of Ordinances, Section 35.13](#). Prohibited communication includes all contact or interaction, including but not limited to telephonic communications, emails, faxes, letters, or personal meetings, such as lunch, entertainment, or otherwise. The City reserves the right to reject the response of any contractor violating this provision. Further information of this topic can be found on the Cone of Silence and eBid Communication Document.

1.3. eBid Scope of Requested Commodities

Furnish all labor, equipment, and materials to remove and replace the existing 8000-gallon above ground diesel fuel tank (including fuel piping lines to existing day tank) at the Southport Booster Pump Station, remove and legally dispose of the existing 2500-gallon above ground diesel fuel tank & 300-gallon diesel fuel day tank. Work will also include the removal of all above ground & underground fuel piping lines that connect to the 2500-gallon and 300-gallon fuel tanks at Southport WWTP.

1.4. Overview of the eBid Process

The objective of the eBid is to select one or more qualified Contractors (as defined by Section 1.1 "Purpose of the Procurement") to provide the goods and/or services outlined in this eBid to the City. This eBid process will be conducted to gather and evaluate responses from Contractor for potential award. All qualified Contractors are invited to participate by submitting responses, as further defined below. After evaluating all Contractor's responses received prior to the closing date of this eBid and resolution of any contract exceptions, the preliminary results of the eBid process will be publicly announced, by the City Clerk's office, including the names of all participating Contractors and the evaluation results. Subject to the protest process, final contract award(s) will be publicly announced thereafter.

NOTE TO CONTRACTORS: The general instructions and provisions of this document have been drafted with the expectation that the City may desire to make one award or multiple awards. For example, this document contains phrases such as “contract(s)” and “award(s)”. Please refer to Section 1.1 “Purpose of the Procurement” and Section 6.4 “Selection and Award” for information concerning the number of contract awards expected.

1.5. Schedule of Events

The schedule of events set out herein represents the City’s best estimate of the schedule that will be followed. However, delays to the procurement process may occur which may necessitate adjustments to the proposed schedule. If a component of this schedule, such as the close date, is delayed, the rest of the schedule may be shifted as appropriate. Any changes to the dates up to the closing date of the eBid will be publicly posted prior to the closing date of this eBid. After the close of the eBid, the City reserves the right to adjust the remainder of the proposed dates, including the dates for evaluation, award and the contract term on an as needed basis with or without notice.

Description	Date	Time
Release of eBid	As Published on DemandStar	N/A
Bidders/Offerors’ Conference & Site Visit Location: Community Center, TOT Room, 2195 SE Airoso Blvd., Port St. Lucie, Florida, 34984 RSVP is Mandatory Attendance is: Not Mandatory	Friday, April 1, 2022 RSVP is required to attend.	As Published on DemandStar
Deadline for written questions sent via email to the Issuing Officer referenced in Section 1.5.	Wednesday, April 6, 2022	5:00 p.m. ET
Responses to Written Questions	Monday, April 11, 2022	5:00 p.m. ET
Bids Due/Close Date and Time	Thursday, April 28, 2022	3:00 p.m. ET
Finalize Contract Terms	2 to 3 Weeks after Closing	N/A
Notice of Intent to Award* [NOIA] (on or about)	3 Weeks after Closing to be Published by the City Clerk’s Office	N/A
Notice of Award [NOA] (on or about)	Date of Executed Contract to Contractor	N/A

The City reserves the right to proceed to award without further discussions after receipt of the initial proposals, in which case, evaluation committee reviews, negotiations and Proposal Revisions may not be required.

*In the event the estimated value of the contract is less than \$75,000, the City reserves the right to proceed directly to contract award without posting a Notice of Intent to Award.

1.6. Official Issuing Officer (Procuring Agent)

Name: Michelle Fentress

Email: mfentress@cityofpsl.com

1.7. Definition of Terms

Please review the following terms:

Contractor(s) – companies desiring to do business with the City (Also called “Bidder”, “Proposer”, or “Offeror”.)

City of Port St. Lucie (City) – the governmental entity identified in Section 1.1 “Purpose of Procurement” of this eBid.

Immaterial Deviation- does not give the contractor a substantial advantage over other contractors.

Material Deviation- gives the contractor a substantial advantage over other contractors and thereby restricts or prevents competition

Procurement Management Division (PMD)- The City department that is responsible for the review and possible sourcing all publicly sourced solicitations.

Responsible- means the contractor, whether a company or an individual, has appropriate legal authority to do business in the City, a satisfactory record of integrity, appropriate financial, organizational and operational capacity and controls, and acceptable performance on previous governmental and/or private contracts, if any.

Responsive- means the contractor, whether a company or an individual, has submitted a timely offer which materially conforms to the requirements and specifications of the solicitation.

Sourcing Platform- [DemandStar](#)

Any special terms or words which are not identified in this eBid Document may be identified separately in one or more attachments to the eBid. Please download, save and carefully review all documents in accordance with the instructions provided in Section 2 “Instructions to Contractors” of this eBid.

1.8. Contract Term

The initial term of the contract(s) is for two hundred and ten (210) days from the issuance of a Purchase Order. In the event that the contract(s), if any, resulting from the award of this eBid shall terminate or be likely to terminate prior to the making of an award for a new contract for the identified products and/or services, the City may, with the written consent of the awarded Contractor(s), extend the contract(s) for such period of time as may be necessary to permit the City’s continued supply of the identified products and/or services. The contract(s) may be amended in writing from time to time by mutual consent of the parties. Unless this eBid states otherwise, the resulting award of the contract(s) does not guarantee volume or a commitment of funds.

1.7.1 Hours of Service

The standard hours of work allowed in the City’s rights-of-way are from 7:00 a.m. to sundown Monday through Friday. Any work performed by the Contractor outside of the aforementioned time limit requires special authorization by the City and requires that the Contractor obtain a noise permit from the City Police Department. All equipment operated at night shall comply with the noise levels established by the City of Port St. Lucie noise ordinance. Any additional costs associated with work outside of the hours of work allowed shall be borne by the Contractor. This shall include, but not be limited to costs of inspection, testing, police assistance, and construction administration.

All night, Saturday, Sunday, and/or Holiday work must be authorized by the City and requires that the Contractor obtain a noise permit from the City Police Department. All night work within the City’s rights-of-way requires a minimum forty-eight (48) hour prior notice to the City. This clause shall not pertain to crews organized to perform maintenance work on equipment or to operate and maintain special equipment such as dewatering pumps, which may be required to work twenty-four (24) hours per day.

2. Instructions to Contractors

2.1. General Information and Instructions

2.1.1. Familiarity with Laws and Regulations

Responding Contractors are assumed to be familiar with all Federal, State and local laws, ordinances, rules and regulations that may affect the work. Ignorance on the part of the Awarded Contractor will in no way relieve them from contract responsibility.

2.1.2. Submitting Questions

All questions concerning this eBid must be submitted in writing via email to the Issuing Officer identified in Section 1.5 “Issuing Officer” of this eBid. No questions other than written will be accepted.

No response other than written will be binding upon the City. All Contractors must submit questions by the deadline identified in the Schedule of Events for submitting questions. Contractors are cautioned that the City may or may not elect to entertain late questions or questions submitted by any other method than as directed by this section. All questions about this eBid must be submitted in the following format:

Company Name

Question #1 Question, *Citation of relevant section of the eBid*

Question #2 Question, *Citation of relevant section of the eBid*

2.1.3. Attending Bidders/Offerors' Conference

The Bidders/Offerors' Conference or any other information session (if indicated in the schedule of events) will be held at the offices referred to in Section 1.4 "Schedule of Events" of this eBid. Unless indicated otherwise, attendance is not mandatory; although Contractors are strongly encouraged to attend. However, in the event the conference has been identified as mandatory, then a representative of the Contractor must attend the conference in its entirety to be considered eligible for contract award. The Contractor is strongly encouraged to allow ample travel time to ensure arrival in the conference meeting room prior to the beginning of any mandatory conference. The City reserves the right to consider any representative arriving late to be "not in attendance." Therefore, all contractors are strongly encouraged to arrive early to allow for unexpected travel contingencies.

2.1.4. The City's Right to Request Additional Information – Contractor's Responsibility

Prior to contract award, the City must be assured that the selected contractor has all of the resources to successfully perform under the contract. This includes, but is not limited to, adequate number of personnel with required skills, availability of appropriate equipment in sufficient quantity to meet the on-going needs the City, financial resources sufficient to complete performance under the contract, and experience in similar endeavors. If, during the evaluation process, the City is unable to assure itself of the contractor's ability to perform, if awarded, the City has the option of requesting from the contractor any information deemed necessary to determine the contractor's responsibility. If such information is required, the contractor will be so notified and will be permitted approximately seven business days to submit the information requested.

2.1.5. Failing to Comply with Submission Instructions

Responses received after the identified due date and time or submitted by any other means than those expressly permitted by the eBid will not be considered. The Contractor's response must be complete in all respects, as required in each section of this eBid.

2.1.6. Rejection of Proposals; The City's Right to Waive Immaterial Deviation

The City reserves the right to reject any or all responses, to waive any irregularity or informality in a Contractor's response, and to accept or reject any item or combination of items, when to do so would be to the advantage of the City. The City reserves the right to waive mandatory requirements provided that all of the otherwise responsive proposals failed to meet the mandatory requirements and/or doing so does not otherwise materially affect the procurement of requested commodities and/or services. It is also within the right of the City to reject responses **that do not contain all elements and information requested in this eBid**. A Contractor's response will be rejected if the response contains any defect or irregularity and such defect or irregularity constitutes a material deviation from the eBid requirements, which determination will be made by the City on a case-by-case basis.

NOTE: The City reserves the right to reject the Bid of any Contractor who has previously failed in the performance of an award or to deliver contracts of a similar nature on time or who is not in a position to perform properly under this award. This includes the firm, employees and financial or legal interests. The City will not enter into a contract or conduct business with any firm or any personnel that is listed on the Federal, State, or other local government agencies' Excluded Parties List, Suspended List or Debarment List. Please see [Florida Statute 287.133](#)

for further information regarding business transactions with companies that have been convicted of public entity crimes.

2.1.7. The City's Right to Amend and/or Cancel the eBid

The City reserves the right to amend this eBid. All revisions must be made in writing prior to the eBid closing date and time. If a responding entity discovers any ambiguity, conflict, discrepancy, omission or other error in the eBid, they shall immediately notify the City of such error in writing and request modification or clarification of the document. Any modification made to this eBid will be issued as an addendum. Written notice will be posted to DemandStar without divulging the source of the request. If a responding entity fails to notify the City prior to the date and time fixed for submission of an error or ambiguity in the eBid known to them, or an error or ambiguity that reasonably should have been known to them, they shall not be entitled to additional time by reason of the error/ambiguity or its late resolution. By submitting a response, the contractor shall be deemed to have accepted all terms and agreed to all requirements of the eBid (including any revisions/additions made in writing prior to the close of the eBid whether or not such revision occurred prior to the time the contractor submitted its response) unless expressly stated otherwise in the contractor's response. **THEREFORE, EACH CONTRACTOR IS INDIVIDUALLY RESPONSIBLE FOR REVIEWING THE REVISED eBID AND MAKING ANY NECESSARY OR APPROPRIATE CHANGES AND/OR ADDITIONS TO THE CONTRACTOR'S RESPONSE PRIOR TO THE CLOSE OF THE eBID.** All Notice(s) of Intent to Award (NOIAs) will be posted as referenced in Section 6.7 of this document. **Contractors are encouraged to frequently check the solicitation documentations and embedded URLs for additional information. Finally, the City reserves the right to amend or cancel this eBid at any time.**

2.1.8. Assigning of the Contract & Use of Subcontractors

Except as may be expressly agreed to in writing by the City, Contractor shall not assign, sell, transfer or otherwise dispose of the Contract or any portion thereof, or of the work provided for therein, or of his right, title or interest therein, to any person, firm or corporation without the written consent of the City.

Each Bidder shall list all subcontractors and the work provided by the suppliers in the area provided on the Bid Reply Sheet. The successful Bidder(s) shall provide a listing of all subcontractors, suppliers, and other persons and organizations (including those who are to furnish the principal items of material and equipment), other than those identified in the Bid Reply, to the City within ten (10) days after the bid opening. Such list shall be accompanied by an experience statement for each such subcontractor, supplier, person or organization if requested by City. The City, after due investigation, has reasonable objection to any proposed subcontractor, supplier, other person or organization, may, before the Notice of Award is given, request apparent successful Bidder to submit an acceptable substitute without an increase in Bid price.

If apparent successful Bidder(s) declines to make any such substitution, City may award the Contract to the next acceptable Bidder(s) that proposes to use acceptable subcontractors, suppliers, and other persons and organizations. Declining to make requested substitutions will not constitute grounds for sacrificing the Bid security of any Bidder(s). Any subcontractor, supplier, other person or organization listed and to whom City does not make written objection prior to the giving of the Notice of Award will be deemed acceptable to City subject to revocation of such acceptance after the effective date of the Contract.

No subcontract which Contractor enters into with respect to performance of obligations or work assigned under the Contract shall in any way relieve Contractor of any responsibility, obligation or liability under this Contract and for the acts and omissions of all Subcontractors, agents, and employees. All restrictions, obligations and responsibilities of the Contractor under the Contract shall also apply to the Subcontractors. Any contract with a Subcontractor must also preserve the rights of

the City. The City shall have the right to request the removal of a Subcontractor from the Contract with or without cause.

2.1.9. Proposal of Addition Services

If a Contractor indicates an offer of services in addition to those required by and described in this eBid, these additional services may be added to the original contract at the sole discretion of the City.

2.1.10. Protest Process

Proposers should familiarize themselves with the procedures set forth in [City Ordinance 20-15 Sec. 35.14.](#)

2.1.11. Costs for Preparing Responses

Each Contractor's response should be prepared simply and economically, avoiding the use of elaborate promotional materials beyond those sufficient to provide a complete presentation. The cost for developing the response and participating in the procurement process (including the protest process) is the sole responsibility of the Contractor. The City will not provide reimbursement for such costs.

2.1.12. Public Access to Procurement Records

Solicitation opportunities will be publicly advertised as required by city ordinances and state and federal laws. Any material that is submitted in response to this eBid, including anything considered by the Contractor to be confidential or a trade secret, will become a public document pursuant to [Chapter 119 of the Florida Statutes](#). Any claim of confidentiality is waived upon submission, effective after the City's opening of the proposals pursuant to Section 119.07, Florida Statutes. Therefore, the Contractor is hereby cautioned to NOT submit any documents that the Contractor does not want to be made public. The City is allowed to assess a reasonable charge to defray the cost of reproducing documents. A City employee must be present during the time of onsite inspection of documents. PLEASE NOTE: Even though information (financial or other information) submitted by a Contractor may be marked as "confidential", "proprietary", etc., the City will make its own determination regarding what information may or may not be withheld from disclosure. Contractors should review [Chapter 119 of the Florida Statutes](#) for all updates before requesting exceptions from Florida Statutes Chapter 119.

2.2. Submittal Instructions

Submittal Instructions to DemandStar

Listed below are key action items related to this eBid. The Schedule of Events in Section 1.4 identifies the dates and time for these key action items. This portion of the eBid provides high-level instructions regarding the process for reviewing the eBid, preparing a response to the eBid and submitting a response to the eBid.

2.2.1. eBid Released

The release of the eBid is only communicated through the posting of this eBid as an event in [DemandStar](#). This eBid is being conducted through DemandStar an online, electronic tool, which allows a contractor to register, logon, select answers and type text in response to questions, and upload any necessary documents. Each contractor interested in competing to win a contract award must complete and submit a response to this eBid using [DemandStar](#). Therefore, each contractor MUST carefully review the submittal instructions on DemandStar's website and following the submittal guidance that is provided in Section 2.2 of this eBid document.

2.2.2. eBid Review

The eBid (or "Sourcing Event") consists of the following: this document, entitled "City's eBid Document", and any and all information included in the Sourcing Event, as posted to DemandStar, including any and all documents provided by the City as attachments to the Sourcing Event or links contained within the Sourcing Event or its attached documents.

Please carefully review all information contained in the Event, including all documents available as attachments or available through links. Any difficulty accessing the Event or opening provided links or documents should be reported immediately to the Issuing Officer (See Section 1.5). Attached documents may be found as follows:

2.2.3. Preparing a Response

When preparing a response, the Contractor must consider the following instructions:

1. Use the provided worksheets to prepare your response. Enter your responses directly into the worksheet. Unless otherwise directed, do not insert "see attached file" (or similar statements) in the worksheet to reference separate documents.
2. Answer each question in sufficient detail for evaluation while using judgment with regards to the length of response.
3. Proofread your response and make sure it is accurate and readily understandable.
4. Label any and all uploaded files using the corresponding section numbers of the eBid as specified by the City.
5. Use caution in creating electronic files to be uploaded. If the City is unable to open an electronic file due to a virus or because the file has become corrupted, the Contractor's response may be considered incomplete and disqualified from further consideration.
6. Use commonly accepted software programs to create electronic files. The City has the capability of viewing documents submitted in the following format: Microsoft Office 2007 and portable document format file (PDF). Unless the eBid specifically requests the use of another type of software or file format than those listed above, please contact the Issuing Officer prior to utilizing another type of software and/or file format. In the event that the City is unable to open an electronic file because the City does not have ready access to the software utilized by the contractor, the contractor's response will be considered incomplete and disqualified from further consideration.

2.2.4. Submitting, Reviewing, Revising or Withdrawing a Submitted Response

After the response has been submitted, the contractor may view and/or revise its response by logging into DemandStar. Please take note of the following:

1. **BID SUBMISSION.** All bids shall be submitted by completing and returning all required documents. All submittals are required to be electronic and be contained in **two (2) files TOTAL.** No hard copies will be accepted.
 - Upload the Excel Bid Reply Sheet- Schedule A in **Excel Format only.** (Save as File #1).
 - Upload in one file and in the following order: Contractor's General Information Worksheet, Cone of Silence and Communication Document, Contractor's Code of Ethics, E-Verify Form, Non-Collusion Affidavit, Drug Free Workplace Form, Trench Safety, copy of Bid Bond, W-9, copy of Certificate of Insurance, and any license or certifications required for project. (Save as File #2).
2. **REVIEW AND REVISE.** In the event the Contractor desires to revise a previously submitted response, the Contractor may revise the response. If the revisions cannot be completed in a single work session, the Contractor should save its progress." Once revisions are complete, the Contractor **must resubmit** its corrected response. Please permit adequate time to revise and then resubmit the response. Please note submission is not instantaneous and may be affected by several events, such as the contractor temporarily losing a connection to the Internet.
3. **WITHDRAW.** A Contractor may withdraw the proposal by removing all documents from DemandStar prior to the deadline. In the event a Contractor desires to withdraw its response after the closing date and time, the Contractor must submit a request in writing to the Issuing Officer.

3. General Insurance, Bonding, and Permit Requirements

This section contains general business requirements. By submitting a response, the Contractor is certifying its agreement to comply with all of the identified requirements of this section and that all costs for complying with these general business requirements are included in the Contractor's submitted pricing.

3.1. Standard Insurance Requirements

The Contractor shall, on a primary basis and at its sole expense, agree to maintain in full force and effect at all times during the life of this Contract, insurance coverage, limits, including endorsements, as described herein. The requirements contained herein, as well as City's review or acceptance of insurance maintained by Contractor are not intended to and shall not in any manner limit or qualify the liabilities and obligations assumed by Contractor under the Contract.

The parties agree and recognize that it is not the intent of the City of Port St. Lucie that any insurance policy/coverage that it may obtain pursuant to any provision of this Contract will provide insurance coverage to any entity, corporation, business, person, or organization, other than the City of Port St. Lucie and the City shall not be obligated to provide any insurance coverage other than for the City of Port St. Lucie or extend its sovereign immunity pursuant to Section 768.28, Florida Statutes, under its self insured program. Any provision contained herein to the contrary shall be considered void and unenforceable by any party. This provision does not apply to any obligation imposed on any other party to obtain insurance coverage for this project, any obligation to name the City of Port St. Lucie as an additional insured under any other insurance policy, or otherwise protect the interests of the City of Port St. Lucie as specified in this Contract.

1. Workers' Compensation Insurance & Employer's Liability: The Contractor shall agree to maintain Workers' Compensation Insurance & Employers' Liability in accordance with Section 440, Florida Statutes. Employers' Liability and must include limits of at least \$100,000.00 each accident, \$100,000.00 each disease/employee, \$500,000.00 each disease/maximum. A Waiver of Subrogation endorsement shall be provided. Coverage shall apply on a primary basis. Should scope of work performed by Contractor qualify its employee for benefits under Federal Workers' Compensation Statute (example, U.S. Longshore & Harbor Workers Act or Merchant Marine Act), proof of appropriate Federal Act coverage must be provided.
2. Commercial General Liability Insurance: The Contractor shall agree to maintain Commercial General Liability insurance issued under an Occurrence form basis, including Contractual liability, to cover the hold harmless agreement set forth herein, with limits of not less than:

Each occurrence	\$1,000,000
Personal/advertising injury	\$1,000,000
Products/completed operations aggregate	\$2,000,000
General aggregate	\$2,000,000
Fire damage	\$100,000 any 1 fire
Medical expense	\$10,000 any 1 person

3. Additional Insured: An Additional Insured endorsement **must** be attached to the certificate of insurance and must include coverage for on-going and Completed Operations (should be ISO CG2037 & CG2010) under the General Liability policy. Products & Completed Operations coverage to be provided for a minimum of five (5) years from the date of possession by City or completion of contract. Coverage is to be written on an occurrence form basis. Coverage shall apply on a primary and non-contributory basis. A per project aggregate limit endorsement should be attached. Defense costs are to be in addition to the limit of liability. A waiver of subrogation shall be provided in favor of the City. Coverage for the hazards of explosion, collapse and underground property damage (XCU) must also be included when applicable to the work performed. No exclusion for mold, silica or respirable dust or bodily injury/property damage arising out of heat, smoke, fumes, or hostile fire shall apply. Coverage shall extend to independent contractors and fellow employees. Contractual Liability is to be included. Coverage is to include a cross liability or severability of interests provision as provided under the standard ISO form separation of insurers clause.

Except as to Workers' Compensation and Employers' Liability, said Certificate(s) and policies shall clearly state that coverage required by the Contract has been endorsed to include the City of Port St. Lucie, a municipality of the State of Florida, its officers, agents and employees as Additional Insured added to its Commercial General Liability policy and Business Auto policy. The name for the Additional Insured

endorsement issued by the insurer shall read **"City of Port St. Lucie, a municipality of the State of Florida, its officers, employees and agents and shall include Contract #20220028 – Remove & Replace 8,000 Gallon Diesel Fuel Tank at Southport Booster Station Project be listed as additionally insured."** The Policies shall be specifically endorsed to provide thirty (30) day written notice to the City prior to any adverse changes, cancellation, or non-renewal of coverage thereunder. In the event that the statutory liability of the City is amended during the term of this Contract to exceed the above limits, the Contractor shall be required, upon thirty (30) days written notice by the City, to provide coverage at least equal to the amended statutory limit of liability of the City. Copies of the Additional Insured endorsements including Completed Operations coverage shall be attached to the Certificate of Insurance.

4. Automobile Liability Insurance: The Contractor shall agree to maintain Business Automobile Liability at a limit of liability not less than \$1,000,000.00 each accident covering any auto, owned, non-owned and hired automobiles. In the event, the Contractor does not own any automobiles; the Business Auto Liability requirement shall be amended allowing Contractor to agree to maintain only Hired & Non-Owned Auto Liability. This amended requirement may be satisfied by way of endorsement to the Commercial General Liability, or separate Business Auto Coverage form. Certificate holder must be listed as additional insured. A waiver of subrogation shall be provided. Coverage shall apply on a primary non-contributory basis.
5. Pollution Insurance: Contractor shall procure and agree to maintain in full force during the term of this Agreement, Pollution Liability Insurance in limits not less than \$1,000,000 per occurrence, \$2,000,000 aggregate, for any operations relating to the handling, storage, and transportation of hazardous materials and/or waste. The City of Port St. Lucie shall be listed as an additional insured. A waiver of subrogation shall be provided in favor of the City. Coverage shall apply on a primary and non-contributory basis.
6. Waiver of Subrogation: The Contractor shall agree by entering into this Contract to a Waiver of Subrogation for each required policy. When required by the insurer, or should a policy condition not permit an Insured to enter into a pre-loss Contract to waive subrogation without an endorsement then Contractor shall agree to notify the insurer and request the policy be endorsed with a Waiver of Transfer of Rights of Recovery Against Others, or its equivalent. This Waiver of Subrogation requirement shall not apply to any policy where a condition to the policy specifically prohibits such an endorsement, or voids coverage should Contractor enter into such a Contract on a pre-loss basis..
7. Deductibles: All deductible amounts shall be paid for and be the responsibility of the Contractor for any and all claims under this Contract. Where an SIR or deductible exceeds \$5,000, the City of Port St. Lucie reserves the right, but not obligation, to review and request a copy of the bidder's most recent annual report or audited financial statement.

It shall be the responsibility of the Contractor to ensure that all independent contractors and/subcontractors comply with the same insurance requirements as listed herein, including Products & Completed Operations coverage for a minimum of five (5) years from the date of possession by City or completion of contract. It will be the responsibility of the Contractor to obtain Certificates of Insurance from all contractors and subcontractors listing the City as an Additional Insured, without the language when required by written contract. If contractor, independent contractor or subcontractor maintain higher limits than the minimums shown above, the City requires and shall be entitled to coverage for the higher limits maintained by contractor/independent contractor/subcontractor.

The Contractor may satisfy the minimum limits required above for either Commercial General Liability, Business Auto Liability, or Employers' Liability coverage under Umbrella or Excess Liability. The Umbrella or Excess Liability shall have an Aggregate limit not less than the highest "Each Occurrence" limit for either Commercial General Liability, Business Auto Liability, or Employers' Liability. When required by the insurer, or when Umbrella or Excess Liability is written on Non-Follow Form," the City shall be endorsed as an "Additional Insured."

The City, by and through its Risk Management Department, reserves the right, but not obligation, to review, modify, reject, or accept any required policies of insurance including limits, coverages or endorsements, herein from time to time throughout the term of this contract. All insurance carriers must have an AM Best rating of at least A:VII or better.

A failure on the part of the contractor to execute the contract and/or punctually deliver the required insurance, and other documentation may be cause for annulment of the award.

Contractor must review the City's Standard Contract for further details and coverage requirements.

Within ten (10) business days of award, the awarded contractor must procure the required insurance and provide the City with an executed Certificate of Insurance. Certificates must reference the contract number and the City as the additional Insured party. The Contractor's submitted pricing must include the cost of the required insurance. No contract performance shall occur unless and until the required insurance certificates are provided.

3.2. Bonds and/or Letter of Credit

Bid Bond

Each responding Contractor must supply a Bid Bond or Bid Deposit (certified check, cashier's check, bank money order, bank draft of any national or state bank), in a sum of not less than **5% of the total contract amount** made payable to the City. As a **Mandatory Requirement**, the Bid Bond or Bid Deposit must be scanned and uploaded into [DemandStar](#) along with all other required documents, thus showing evidence that a Bid Bond or Bid Deposit was obtained. Responding Contractors must send the Original Bid Bond or Bid Deposit to the City within five (5) days after the eBid Due Date as reflected above in Section 1.4. The responding Contractor's bid will be considered non-responsive if the Bid Bond or Bid Deposit is not received within the specified time frame. Responding Contractors must submit a Bid Bond or Bid Deposit made payable to the City in a sealed envelope to:

Michelle Fentress
121 S.W. Port St. Lucie Blvd.
Port St. Lucie, FL 34984
Attn: Procurement Management Department

Bonds must be issued by a Surety authorized to do business in the State of Florida, in order to guarantee that the contractor will enter into a contract to deliver products and/or related services outlined in this solicitation, strictly within the terms and conditions stated in the contract.

3.2.1 Proposal Certification

By responding to this solicitation, the Contractor understands and agrees to the following:

1. That this electronically submitted proposal constitutes an offer, which when accepted in writing by the City, and subject to the terms and conditions of such acceptance, will constitute a valid and binding contract between the Contractor and the City; and
2. That the Contractor guarantees and certifies that all items included in the Contractor's response meet or exceed any and all of the solicitation's identified specifications and requirements except as expressly stated otherwise in the Contractor's response; and
3. That the response submitted by the Contractor shall be valid and held open for a period of **one hundred and twenty (120) days** from the final solicitation closing date and that the Contractor's offer may be held open for a lengthier period of time subject to the Contractor's consent; and
4. That the Contractor's response is made without prior understanding, agreement, or connection with any corporation, firm, or person submitting a response for the same materials, supplies, equipment, or services and is in all respects fair and without collusion or fraud. Contractor understands and agrees that collusive bidding is a violation of city ordinance, state and federal laws and can result in fines, prison sentences, and civil damage awards.

- 3.3 Payment and Performance bonds must remain in full force and effect for a minimum of one (1) year after the work has been completed and final acceptance of the work is issued by the City.

Payment Bond

The awarded contractor(s) shall be required to furnish a recorded bond to secure payment of all claims for materials furnished and/or labor performed. The payment bond shall be in amount equal to the contract price.

Performance Bond/Letter of Credit

The awarded contractor(s) shall be required to furnish a recorded performance bond or an irrevocable letter of credit to the City for the faithful performance on the contract in an amount equal to the contract price. The bond shall be issued by a Corporate Surety authorized to do business with the State of Florida. The performance bond/letter of credit must be submitted to the City within ten (10) calendar days of the date the contract is approved by city council, but in any event, prior to the beginning of any contract performance by the awarded contractor.

3.4. Permits

The selected Contractor shall be responsible for obtaining all permits, licenses, certifications, etc., required by federal, state, county, and municipal laws, regulations codes, and ordinances for the performance of the work required in these specifications and to conform to the requirements of said legislation. Certain aspects of construction may not be allowed to occur until after these permits have been obtained. All building permits, licenses and certificates of inspection issued in connection with the work shall be delivered to the Engineer and the City with successful Contractor(s) application for final payment. Permit fees can be found on the [City's Building Department Website](#). All permit fees shall be included in the contract amount and paid by the successful Contractor(s).

4. eBid Bid Factors

This section contains the detailed technical requirements and related services for this Sourcing Event. The City has determined that it is best to define its own needs, desired operating objectives, and desired operating environment. The City will not tailor these needs to fit a particular solution a contractor may have available; rather, the Contractors shall propose to meet the City's needs as defined in this eBid. All claims shall be subject to demonstration. Contractors are cautioned that conditional responses/bids, based upon assumptions, may be deemed non-responsive.

Unless requested otherwise, all responses must be provided within the provided forms/Excel worksheets included with this Sourcing Event. Except as otherwise indicated, all requested forms and documents must be submitted electronically via the sourcing tool as an uploaded document to the contractor's response.

4.1. Introduction

All of the items described in this section are service levels and/or terms and conditions that the City expects to be satisfied by the selected Contractor. Each Contractor must indicate its willingness and ability to satisfy these requirements in the Contractor's submitted response.

Unless otherwise specified, references to brand name or trade name/mark products are intended to be descriptive, but not restrictive, and are used to indicate the quality and characteristics of products that may be offered. Other products may be considered for award if such products are clearly identified and are determined by the City to meet its needs in all respects. Each Contractor's response must indicate the brand name and model, or series number of the product offered and include such specifications, catalog pages, or other data that will provide an adequate basis for determining the quality and functional capabilities of the product offered.

4.2. Contractor's General Information

Each contractor must complete all of the requested information in the electronic purchasing system entitled **Contractor's General Information Worksheet** for inclusion with their bid response.

4.3. Mandatory Requirements

As noted in the preceding section, this eBid contains mandatory requirements (e.g. product specifications, service or quality levels, staff requirements, experience or license requirements, etc.) which must be met by the Contractor in order for the Contractor to be considered "responsive" and, therefore, eligible for contract award. These mandatory requirements will be defined in one or more of the following ways:

1. Requirements in this eBid document.
2. Requirements contained in any attachment to the Sourcing Event, such as a Mandatory Requirements Worksheet and the cost worksheet.
3. Copy of Current Insurance Certificate, Licenses, required Certifications, etc.

A Pass/Fail evaluation will be utilized for all mandatory requirements. Please review the Sourcing Event and its attachments carefully and respond as directed.

Some requirements may require a "Yes" or "No" response. Ordinarily, to be considered responsive, responsible and eligible for award, all requirements identified as mandatory must be marked "YES" to pass. There may be rare instances in which a response of "NO" is the correct and logical response in order to meet the mandatory requirement (e.g. responding "NO" that the Contractor does not possess any conflicts of interest). Otherwise, any mandatory questions marked "NO" will fail the technical requirements and will result in disqualification of the Contractor's response, except as otherwise provided in Section 6 "Evaluation and Award" of this eBid. Please note some requirements may require the Contractor to provide product sheets or other technical materials.

It is strongly encouraged that all Contractor's review all documents that are electronically attached to this eBid. Reviewing the documentation ensures that Contractor understands the full scope of the City's request.

5. Cost/Pricing

Each Contractor is required to submit pricing as part of its response.

5.1. General Pricing Rules

By submitting a response, the Contractor agrees that it has read, understood, and will abide by the following instructions/rules:

1. The submitted pricing must include all costs of performing pursuant to the resulting contract; and
2. All quantities and/or estimates are for information or tabulation purposes only and;
3. No warranty or guarantee is expressed or implied on the volume of products and/or services that the City may require through the negotiated contract period and;
4. Bids containing a minimum order/ship quantity or dollar value, unless otherwise called for in the eBid, will be treated as non-responsive and may not be considered for award; and
5. The Contractor is required to provide net prices. In the event there is discrepancy between a Contractor's unit price and extended price, the unit price shall govern;
6. In the event there is a discrepancy between (1) the Contractor's pricing as quoted on an uploaded, detailed cost sheet such as an Excel Worksheet (if any) and (2) the Contractor's pricing as quoted by the Contractor in one or more single line entries directly into the Sourcing Event screen, the former shall govern; and
7. The prices quoted and listed in the response shall be firm throughout the term of the resulting contract, unless otherwise noted in the eBid or contract; and
8. Unless otherwise specified in any terms and conditions attached to the eBid, all product deliveries will be F.O.B. destination and all shipping charges must be included in the quoted cost; and

9. Unless expressly permitted by the eBid, responses containing provisions for late or interest charges cannot be awarded a contract. Contractors must “strikethrough” any such provisions in printed forms and initial such revisions prior to submitting a response to the City; and
10. Contractor responses requiring prepayment and/or progress payment requirements may be determined non-responsive unless otherwise permitted by the eBid; and
11. Unless permitted by the eBid, responses requiring payment from the City in less than thirty (30) days will be considered non-responsive; and
12. The City is exempt from certain taxes and no provision for such taxes should be included in the contractor’s response.

5.2 Cost Structure and Additional Instructions

The City’s intent is to structure the cost format in order to facilitate comparison among all Contractors and foster competition to obtain the best market pricing. Consequently, the City requires that each Contractor’s cost be structured as directed in the eBid. Additional alternative cost structures will not be considered. Each Contractor is hereby advised that failure to comply with the eBid instructions, submission of an incomplete offer, or submission of an offer in a different format than the one requested may result in the rejection of the Contractor’s response.

Enter all information directly into the cost sheet(s). Enter numbers on each cost sheet in “number” (two-place decimal), not “currency” or other format unless otherwise stated. That is, omit dollar signs, commas, and any other non-essential symbols. (e.g., \$7.90 should be entered as 7.90) Prices must be in US Dollars. Enter “n/a” to indicate not available or “0” if there is no charge. Cells left blank will be interpreted as “no offer”.

Download the cost worksheet (if any), complete the worksheet and then upload the worksheet by following the instructions in DemandStar

5.3 Payment by City’s Visa Card Program

The City currently utilizes the State of Florida [Visa Program](#). The awarded Contractor can take advantage of this program and in consideration, receive payment within several days instead of NET 30 terms. Any percentage off the quoted bid price for the acceptance of payment by Visa will be taken into account for consideration of the best value to the City. If no percentage is provided in the cost proposal, the City shall assume zero (0) percent discount applies.

6. Evaluation and Award

All timely responses will be evaluated in accordance with the following steps. The objective of the evaluation process is to identify the most competitive bid. Once the evaluation process has been completed, the apparent successful Contractor(s) will be required to enter into discussions with the City to resolve any exceptions to the City’s contract. The City will announce the results of the eBid as described further in Section 6.7 “Public Award Announcement.”

6.1. Administrative/Preliminary Review

First, the responses will be reviewed by the Issuing Officer to determine compliance with the following requirements:

1. Response was submitted by deadline via in accordance with Section 2
2. Response is complete and contains all required documents

6.2. Evaluating Bid Factors (Section 4)

If the Contractor’s response passes the Administrative/Preliminary Review, the Contractor’s responses to Section 4 “eBid Bid Factors” will be evaluated. Responses to mandatory requirements will be evaluated on a pass/fail basis. If a response fails to meet a mandatory requirement, the City will determine if the deviation is material. A material deviation will be cause for rejection of the response. An immaterial deviation will be processed as if no deviation had occurred.

6.3. Evaluating Cost

The City may utilize lowest cost, lowest total cost, and total cost of ownership (TCO) or greatest savings to determine the most competitive pricing. Submitted pricing may be evaluated/scored on an overall basis or at the category/subcategory/line level (as applicable) relative to other responses/bids.

6.4. Selection and Award

The City reserves the right to: (a) waive minor irregularities, variances or non-material defects in a response; (b) reject any and all responses, in whole or in part; (c) request clarifications from Contractors; (d) request resubmissions from all Contractors; (e) award in whole, in part; or by line item and (f) take any other action as permitted by law. The City reserves the right to provide for similar and/or additional services from other companies if the City so deems necessary. If the City elects to exercise this right, the contract awarded under this solicitation shall remain in effect as for to all terms, agreements, and conditions without penalty or diminution of ongoing services as contained therein. Contractor agrees and understands that any contract awarded pursuant to this solicitation shall not be construed as an exclusive arrangement and further agrees that the City may, at any time, secure similar or identical services, or award more than one contract under this solicitation, at its sole option.

The primary intent of this eBid is to identify a single source (Responsive and Responsible Contractor with the best value as evaluated in Section 6.3) to provide all of the needed goods and/or services; however, the City reserves the right to make split awards.

6.5. Local Preference in Purchasing or Contracting ([Sec. 35.12, Ord. No. 10-26](#))*

Except where otherwise provided by federal or state law or other funding source restrictions or as otherwise set forth in the purchasing policy. The City of Port St. Lucie shall give preference to local businesses in the following manner:

1. In purchasing of, or letting of contracts for procurement of, personal property, materials, contractual services, and construction of improvements to real property or existing structures for which a request for proposals is developed with evaluation criteria, a local preference of the total score may be assigned as follows:
 - a. Local businesses which meet all of the criteria for a local business as set forth in this section, shall be given a preference in the amount of five percent (5%) of the total quoted price of the local business.
 - b. The City Procurement Management Division shall have the sole discretion to determine if a Contractor meets the definition of a "local business."
2. Limitations:
 - a. The provisions of this section shall apply only to procurements which are above the formal bid threshold as set forth in the City Code and the City of Port St. Lucie Purchasing Manual.
 - b. The provisions of this ordinance shall not apply to any purchase exempted from the provisions of the City of Port St. Lucie Purchasing Manual.
 - c. The provisions of this ordinance shall not apply to contracts made under the Contractors [Competitive Negotiation ACT \(CCNA\), Section 287.55, Florida Statutes](#).

* Please review ([Sec. 35.12, Ord. No. 10-26](#)) for the full governing ordinance

6.6. Site Visits, Samples, and Oral Presentations

The City reserves the right to conduct site visits, request product/work samples, or to invite Contractors to present their product(s) and or service solutions to the evaluation team. Unless prohibited by federal, state, county, or local laws and/or ordinances, all Contractor requested presentations shall be performed in an in-person meeting. An oral presentation or product demonstration is not a negotiation and Contractors are not permitted to revise their responses as part of the presentation and/or demonstration. Samples of items, when required, must be furnished free of expense and, if not destroyed, will upon request, be returned at the Contractor's expense. Request for the return of samples must be made within thirty (30) days following

opening of bids. Each individual sample must be labeled with Contractor's name, bid number, and item number. Failure of Contractor to either deliver required samples or to clearly identify samples as indicated may be reason for rejection of the bid. Unless otherwise indicated, samples should be delivered to the Procurement Management Department.

6.7. Public Award Announcement

The preliminary results of the evaluation will be announced through the public posting of a Notice of Intent to Award by the City Clerk's Office, pending final approval by the City Council at a publicly noticed meeting. The Notice of Intent to Award ("NOIA") is not notice of an actual contract award; instead, the NOIA is notice of the City's expected contract award(s) pending resolution of the protest process period pursuant to City Code of Ordinances, Section 35.14. The NOIA (if any) will identify the apparent successful contractor(s), unsuccessful contractor(s), and the reasons why any unsuccessful contractors were not selected for contract award. **NO CONTRACTOR SHOULD ASSUME PERSONAL NOTICE OF THE NOTICE OF INTENT TO AWARD ("NOIA") WILL BE PROVIDED BY THE CITY. INSTEAD, ALL CONTRACTORS SHOULD FREQUENTLY CHECK [THE CITY CLERK'S WEBSITE](#) FOR NOTICE OF THE NOIA DURING A CITY COUNCIL MEETING.**

7. Contract Terms and Conditions

The contract that the City expects to award as a result of this eBid will be based upon the eBid, the successful Contractor's final response as accepted by the City and the contract terms and conditions, which terms and conditions can be downloaded from [DemandStar](#). The "successful Contractor's final response as accepted by the City" shall mean: the response submitted by the awarded Contractor, written clarifications, and any other terms deemed necessary by the City, except that no objection or amendment by a Contractor to the eBid requirements or the contract terms and conditions shall be incorporated by reference into the contract unless the City has explicitly accepted the Contractor's objection or amendment in writing.

Please review the [City's contract terms and conditions](#) prior to submitting a response to this eBid. Contractors should plan on the contract terms and conditions contained in this eBid being included in any award as a result of this eBid. Therefore, all costs associated with complying with these requirements should be included in any pricing quoted by the Contractors. The contract terms and conditions may be supplemented or revised before contract execution and are provided to enable Contractors to better evaluate the costs associated with the eBid and the potential resulting contract.

Exception to Contract

By submitting a response, each Contractor acknowledges its acceptance of the eBid specifications and the contract terms and conditions without change except as otherwise expressly stated in the submitted proposal. If a Contractor takes exception to a contract provision, the Contractor must state the reason for the exception and state the specific contract language it proposes to include in place of the provision. Any exceptions to the contract must be uploaded and submitted as an attachment to the Contractor's response. Proposed exceptions must not conflict with or attempt to preempt mandatory requirements specified in the eBid.

In the event the Contractor is selected for potential award, the Contractor will be required to enter into discussions with the City to resolve any contractual differences before an award is made. These discussions are to be finalized and all exceptions resolved within the period of time identified in the schedule of events. Failure to resolve any contractual issues will lead to rejection of the Contractor's response. The City reserves the right to proceed to discussions with the next best ranked Contractor.

The City reserves the right to modify the contract to be consistent with the apparent successful offer, and to negotiate other modifications with the apparent successful Contractor. Exceptions that materially change the terms or the requirements of the eBid may be deemed non-responsive by the City, in its sole discretion, and rejected. Contract exceptions which grant the Contractor an impermissible competitive advantage, as determined by the City, in its sole discretion, will be rejected. If there is any question whether a particular contract exception would be permissible, the Contractor is strongly encouraged to inquire via written question submitted to the Issuing Officer prior to the deadline for submitting written questions as defined by the Schedule of Events.

This eBid and the proposal response documents submitted shall be incorporated into the final contract by reference. Therefore, all requirements in the eBid not specifically addressed in an exception statement in the proposal and accepted in the contract documents, shall stand as contractual responsibilities of the proposal respondent. The Contract shall be the controlling document over the Proposal response and the eBid; the eBid shall be the ruling document over the Proposal response for all requirements in the eBid not specifically addressed in an exception statement in the proposal. Statement and requirements in the eBid shall rule over the Proposal document.

Order of Preference

In the case of any inconsistency or conflict among the specific provisions of the executed contract (including any amendments accepted by both the City and the Contractor attached hereto), the eBid (including any subsequent addenda and written responses to bidders' questions), and the Contractor's Response, any inconsistency or conflict shall be resolved as follows:

- (i) First, by giving preference to the specific provisions of the executed contract.
- (ii) Second, by giving preference to the specific provisions of the eBid.
- (iii) Third, by giving preference to the specific provisions of the Contractor's Response, except that objections or amendments by a contractor that have not been explicitly accepted by the City in writing shall not be included in this Contract and shall be given no weight or consideration.

8. Payment

To ensure proper payment the awarded Contractor must:

1. The City shall have not less than 30 days to pay for any products and/or services.
2. Invoices must clearly show the description of products and/or services to include the number of each product or line item fulfilled.
3. All invoices must reference the Contract Number as established by the City.
4. Under no circumstance, will interest of any kind be required as payment to the Awarded Contractor.
5. All charges, e.g., set up costs, must be included in the cost proposal. No charges will be allowed unless specified in the eBid and agreed upon by the City.
6. Any discrepancies noted by the City must be corrected by the Awarded Contractor within 48 hours.
7. The payment amount due on invoices shall not be altered by the City personnel. Once disputed items are resolved, the Awarded Contractor must submit an amended invoice, or a credit memorandum for the disputed amount.
8. The City will not make partial payments on an invoice where there is a dispute.
9. The City will only make payments on authorized transactions.
10. All invoices must be sent to: apnotifications@cityofpsl.com

9. List of eBid Attachments

The following documents make up this eBid. Please see Section 2.2.2 "eBid Review" for instructions about how to access the following documents. Any difficulty locating or accessing the following documents should be immediately reported to the Issuing Officer.

- ❖ PSL eBid (this document)

Attachments:

- A. Scope of Work (Attached)
- B. Construction Plans (Attached)
- C. Excel Bid Reply- Schedule A from Section 5 of this eBid- Must be uploaded to DemandStar (Mandatory Document) as **File #1**.
- D. Sample Contract (Attached)
- E. Other Mandatory Documents- Must be uploaded to DemandStar as **File #2**:
 - Contractor's General Information Worksheet/ Questionnaire
 - Cone of Silence and Communication Document from Section 2.1.2 of this eBid

- Contractor's Code of Ethics
- Lobbying Form
- E-Verify Form
- Non-Collusion Affidavit
- Drug Free Workplace Form
- Trench Safety

****Any documents indicated in Section 4.3 of this eBid must be returned in the system as a part of the response by the Contractor. Failure to supply the completed document(s) will deem the Contractor as non-responsive.**

SCOPE OF WORK

Attachment A

Solicitation: #20220028

Remove & Replace 8,000-Gallon Diesel Fuel Tank at Southport Booster Station

Furnish all labor, equipment, and materials to remove and replace the existing 8000-gallon above ground diesel fuel tank (including fuel piping lines to existing day tank) at the Southport Booster Pump Station, remove and legally dispose of the existing 2500-gallon above ground diesel fuel tank & 300-gallon diesel fuel day tank. Work will also include the removal of all above ground & underground fuel piping lines that connect to the 2500-gallon and 300-gallon fuel tanks at Southport WWTP.

The work also includes:

- Applying and obtaining all the necessary City, FDEP and Palm Beach County Resource Management Permitting Requirements.
- Remove and transport approximately 4000 gallons of diesel fuel from existing 8000-gallon above ground tank at Southport Booster Pump Station to Glades Booster Pump station. The remaining 2500 gallons of diesel fuel is to be stored in a temporary standby storage tank (supplied by the Contractor) during the replacement of the existing 8000-gallon above ground tank. The existing diesel fuel supply & return piping (from existing 8000-gallon tank to a day tank inside generator room) is to be removed and legally dispose of from the site after both pipes have been cleaned in accordance with FDEP and Palm Beach County Resource Management Closure Permitting requirement by the contractor.
- The Existing above ground & underground fuel supply & return piping from the 2500-gallon tank to the 300-gallon day tank to a Generator (inside generator building), must be removed and legally disposed of at Southport WWTP.
- The Contractor is responsible for the removal of existing diesel fuel by transporting and disposing of biohazardous wastes produced during the cleaning and demolition process of the existing 8000-gallon tank, 2500-gallon tank and 300-gallon day tank at Southport Booster Pump Station and WWTP.
- Remove and dispose of the existing 8000-gallon above ground diesel fuel tank at booster pump stations, the 300-gallon day tank at Southport WWTP and the 2500-gallon above ground tank including the complete restoration of both sites.
- The Contractor is responsible for installing a 2500-gallon above ground double wall-fire guard temporary standby diesel fuel tank at the Booster Pump Station site including all the necessary supply & return pipes, connections to the existing 250-gallon day tank & all the accessories (during replacement of existing 8000-gallon tank). Diesel fuel will be supplied by the city.

- The Contractor may use the Booster Pump Station site to demolish the concrete encasement of the existing above ground 8000-gallon diesel fuel tank prior to its removal & disposal. Demolished concrete materials must be removed and legally dispose of including complete restoration.
- The existing 8000-gallon above ground tank fuel lines steel-aluminum support railing, steel-aluminum ladder & catwalk must be disassembled at the site and return to the city.
- The existing 8000-gallon tank's 12" thick reinforced concrete pad and existing concrete bollards must be protected at all times during construction. The Contractor is responsible for repair and replacement of any damages to the existing 12" thick concrete pad and concrete bollards during demolishing, removal and disposal of existing 8000-gallon tank.
- The existing electrical panels, junction boxes, wirings, communication wiring and sensors must always be protected during the removal of the existing 8000-gallon tank and it may be used to connect to a new 8000-gallon diesel fuel tank pending the tank's manufacturer recommendation. Any new required installation of electrical panels with breaker, junction boxes, electrical wirings, communication wirings, 5G Cellular communication, and sensors for a new 8000-gallon diesel fuel tank will be paid separately.
- The Contractor is responsible to drill four (4) 4" diameter holes on the existing concrete containment wall to drain all rainwater onto the surrounding field at Southport WWTP. The cost should be included in the 2500-gallon above ground diesel fuel tank and 300-gallon day tank removal and disposal.
- The new 8000-gallon above ground fireguard diesel fuel tank should be a cylindrical and horizontal steel tank welded on two (2) saddles with an inner-primary and outer-secondary tank. The tank should be a minimum of ¼" steel thickness for the shell and heads of both inner and outer tanks, filled with 6" thick lightweight monolithic thermal material insulation (between primary and secondary tank) per standards specifications of UI 2085, UI142, UI 567 and NFPA 30. It should also have leak detection, level control and other accessories, aluminum platform and aluminum side mount ladder from the stair base slab to the top of the tank. It should include aluminum stairs, aluminum handrail alloy 6061, grating and appurtenances.
- The new 8000-gallon above ground fireguard diesel fuel tank should have continuous weld on all sides per UI 142, reinforce threaded openings or flanges for all pipe connections, including fill, supply, electronic fuel level sensor, internal monitoring port, vents, and manholes., All threaded openings shall be seamless black steel, schedule 40, conforming to ASTM A53, malleable iron, ANSI B16.3, Class 150.
- The new 8000-gallon above ground fireguard diesel fuel tank should have an emergency vent per NFPA 30 requirement, 5 feet of 2-inch stainless steel stack vent pipe with all the fittings. It should have a cast iron cover with a non-sparking O-ring gasket for relief of tank pressure. The emergency vent should be an 8" diameter MORR Model 244 or equivalent. It should also have a 24" diameter bolted manhole. The steel tank shall be pressurized at

the casting facility and tested per UI 142 requirement. It should also have a two-hour fire wall as required by Uniform Fire Code with fire safety labels on the tank sides. The outer surface of the steel tank should be coated with a rust proofing exterior oxide coating with finish painting of white urethane paint system on the shell and heads. The two (2) 1½” supply and return steel pipes should be painted red.

- The new 8000-gallon above ground fireguard diesel fuel tank should have a 3” x 4” vapor recovery adaptor OPW model 1711T or approved equivalent. It should have overfilled protection to prevent overfilling and to prevent excess pressure. These systems should include both automatic and manual shutoff or approved equivalent. The overfill prevention systems shall include ground fill application with a 3” overfill prevention valve C&B model 1228-F-35, ball valve MORR model 691 and a dry-break disconnect with dust cap, OPW Model 1612AN and OPW Model 634B respectively or equivalent. The tank fill shall be enclosed in a seven (7) gallon lockable aluminum containment box. The tank fill piping shall be type 304 stainless steel and it should have a 2” diameter pipe with vent and screen above the top of the tank OPW Model 230033. The tank’s interstitial vent should be OPW model 155. It should have a complete fuel monitoring and inventory measurement system Model TLS-300 C-4 as manufactured by Veeder-Root or equivalent, 3-inch clock gauge MORR 918 series gauge with alarm and standard float on top of the tank with all the accessories, 1-inch aluminum moisture hand pump. The system should be equipped to monitor the 8000-gallon diesel fuel storage tank, The unit shall be equipped with magnetostrictive probes for fuel inventory measurement, interstitial leak sensor and Ethernet-TCP/IP communication card for (LAN/WAN) connection.
- The new 8000-gallon above ground fireguard diesel fuel tank should have a 3” diameter fill line type 304 stainless steel equipped with a lockable drip box, an isolation ball valve, and a quick connect cam-lock coupling. The drip box shall be a minimum of 2’x 2’x 2’ deep and should have a spring-loaded drain plugin the bottom. It should also include 1½” foot valves on the fuel supply line and 1½” isolation ball valves on the supply and return line. All hardware and anchor bolts shall be type 316 stainless steel.
- The new 8000-gallon above ground fireguard diesel fuel tank shall be installed on top of the existing 12” thick reinforce concrete slabs (as shown on the as-built drawing) with four (4) ¾” stainless steel anchor bolts embedded five (5) inches into the concrete. The Contractor shall field paint the fuel tank entirely after installation is completed. Surface preparation shall be in accordance with factory paint system (including providing appropriate labels for tank).
- The new 8000-gallon above ground fireguard diesel fuel tank shall be pressure tested in Accordance with NFPA recommendation practice number 329 and other acceptable procedures (after tank is installed but prior to placing any fuel in the tank).
- The Contractor shall provide all fuel required for startup of the emergency generator system. Upon satisfactory operational demonstration of the emergency generator system, the Contractor shall provide 3000 gallons of no.2 diesel fuel. The diesel fuel shall contain all additives required by the emergency generator system.

- The new 8000-gallon above ground diesel fuel tank shall have a qualified manufacturer's technical representative who shall adequately supervise the installation of the diesel fuel tank. The services of the manufacturer's representative shall be provided for a period not less than three (3) days; one trip of two (21 days during installation of the tank), and one trip of (one day after acceptance of the tank to instruct the owner's personnel in the proper operation and maintenance of the tank).
- The new 8000-gallon above ground diesel fuel tank shall have a 30-year warranty from the tank's manufacturer. The Contractor shall be responsible for the delivery, handling, storage and hauling of the diesel fuel tank to the site. The Manufacturer shall furnish all special tools necessary for services, repairs, and adjustments of the 8000-gallon above ground fireguard diesel fuel tank.
- The new 8000-gallon diesel fuel tank and appurtenance should be Ecovault inc, ConVault Florida, Armocast, Envirosafe and Highland Tank or an approved equivalent.
- The Contractor must complete the entire work (removal and disposal of three (3) fuel tanks, piping, temporary standby tank and installation of one (1) new 8000-gallon above ground diesel tank, supply and return piping, fittings, painting, electrical wirings, sensors, all accessories and all the appurtenance) within **21 business days after** receiving the new above ground 8000 gallons fireguard diesel fuel tank.

CITY OF PORT ST. LUCIE UTILITY SYSTEMS DEPARTMENT SOUTH PORT DIESEL TANK REPLACEMENT ATTACHMENT B

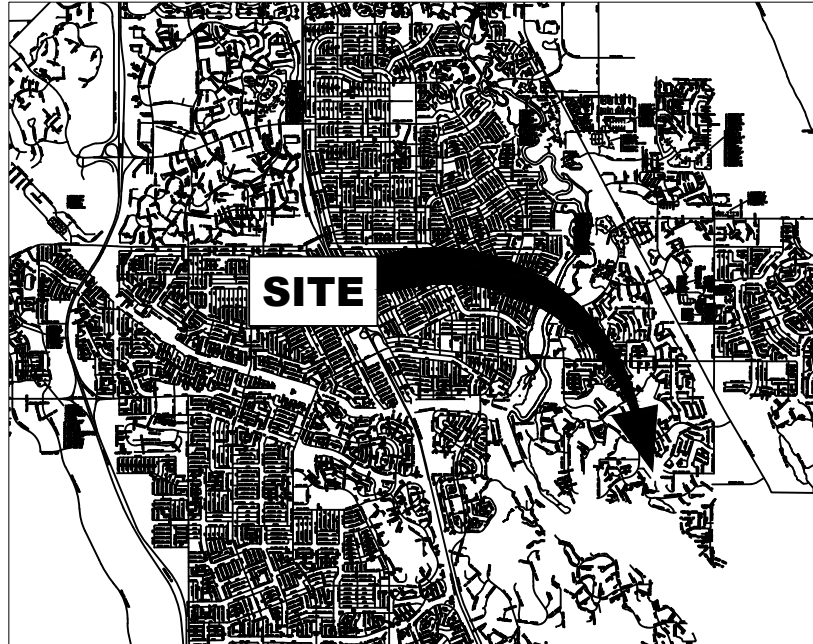

VICINITY MAP
NOT TO SCALE

DRAWING INDEX

1. EXISTING ASBUILT BOOSTER PUMP STATION TANK
2. WWTP EXISTING TANKS
3. WWTP EXISTING TANKS
4. BOOSTER PUMP STATION TANK
5. BOOSTER PUMP STATION TANK
6. BOOSTER PUMP STATION TANK



"A City for All Ages"

PREPARED BY

CITY OF PORT ST. LUCIE
UTILITY SYSTEMS DEPARTMENT
900 S.E. OGDEN LANE
PORT ST. LUCIE, FL 34983
PHONE (772) 873-6400

DECEMBER 2, 2021 PLANS

BRAD MACEK DIRECTOR



LOCATION MAP

ENGINEER OF RECORD

KARIM RAHMANKHAH, P.E.
CITY OF PORT ST. LUCIE
UTILITY SYSTEMS DEPARTMENT
900 S.E. OGDEN LANE
PORT ST. LUCIE, FL 34983
PHONE (772) 873-6400

CITY OF PORT ST. LUCIE
UTILITY SYSTEMS DEPARTMENT
900 S.E. OGDEN LANE
PORT ST. LUCIE, FL 34983
PHONE (772) 873-6400 FAX (772) 873-6433



CITY OF PORT ST. LUCIE
UTILITY SYSTEMS DEPARTMENT
SOUTH PORT DIESEL TANK REPLACEMENT

KNOW WHAT'S BELOW
ALWAYS CALL 811
BEFORE YOU DIG
It's free. It's fast. It's the law.
www.call811.com

SHEET DATA		
DESIGNED	DATE	
DRAWN		
APPROVED		
CAD FILE NAME		
REVISIONS		
NO.	DATE	DESCRIPTION

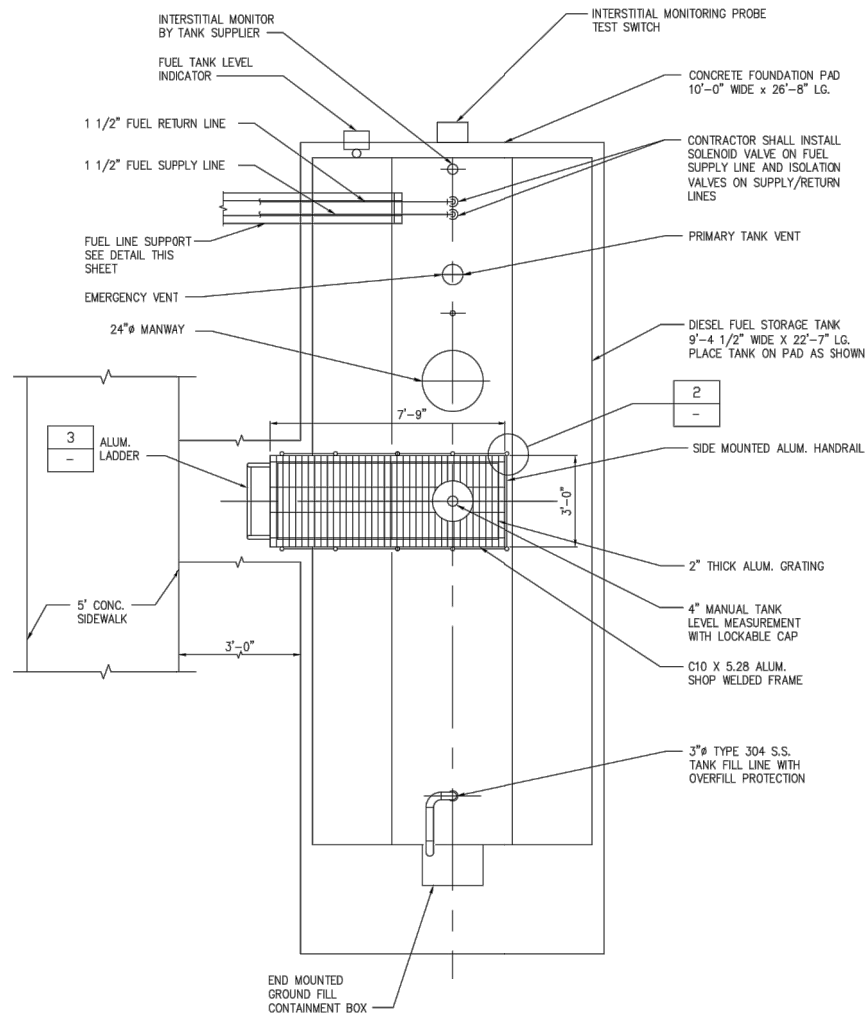

NOTES:
 CONCRETE SLAB DIMENSIONS SHOWN ARE MINIMUM SIZES FOR A TANK WITH DIMENSIONS OF 9'-4 1/2" WIDE x 22'-7" LONG, ANY VARIATION IN TANK SIZE SHALL BE ADJUSTED ACCORDINGLY IN CONCRETE SLAB DIMENSIONS.

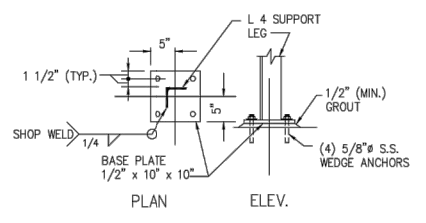
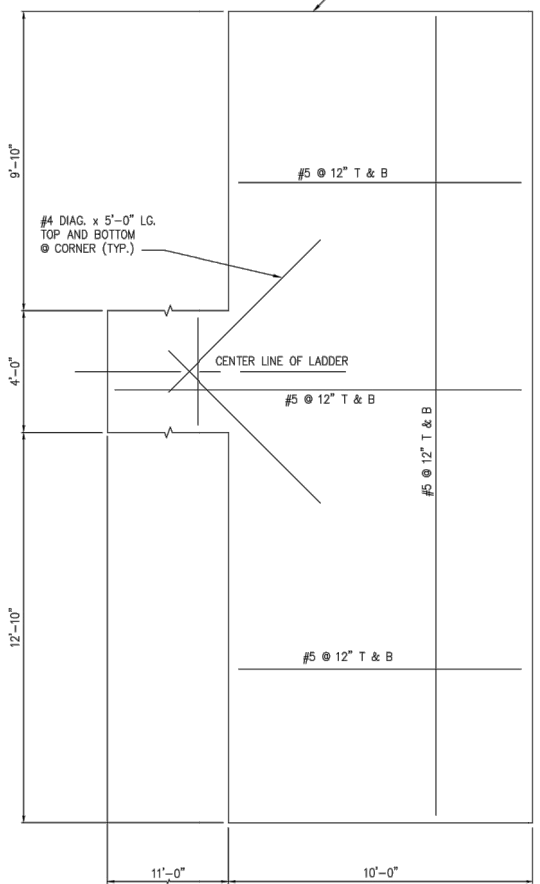

DETAIL	1
3/4"=1'-0"	-

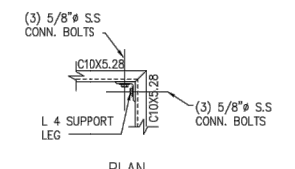

DETAIL	2
3/4"=1'-0"	-

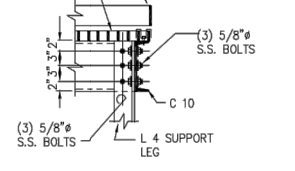

DETAIL	3
3/4"=1'-0"	-

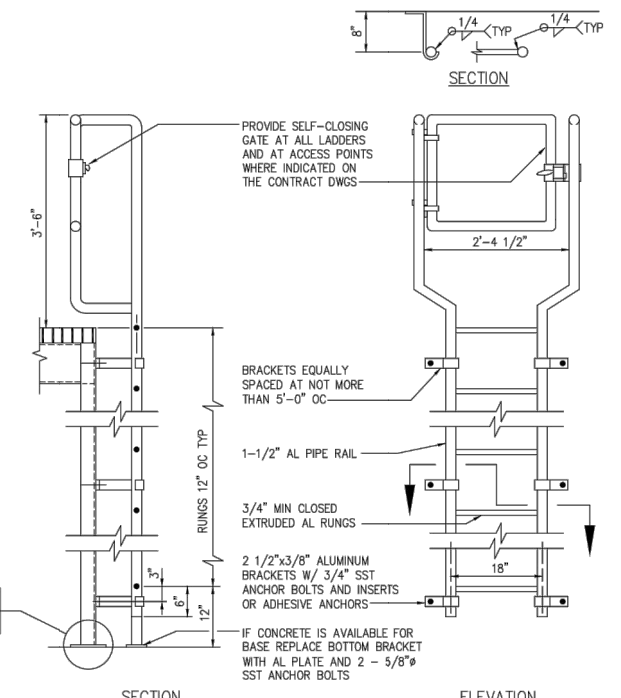

ALUMINUM LADDER

DETAIL	3
3/4"=1'-0"	-

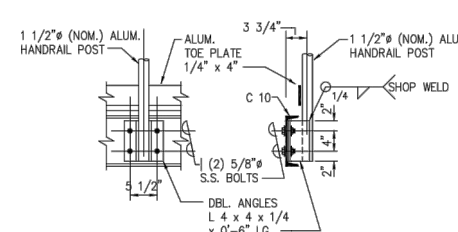

ELEV. SECTION

DETAIL	4
3/4"=1'-0"	-

- NOTES:
 1. PLATFORM, HANDRAIL AND CONTAINMENT BOX SHALL BE STRUCTURAL ALUMINUM IN ACCORDANCE WITH DIVISION 5 OF THE SPECIFICATIONS
 2. ALL PIPE SUPPORTS SHALL BE 316 SS UNISTRUT WITH 316 SS ANCHORS.

FUEL STORAGE TANK PLAN

3/8"=1'-0"

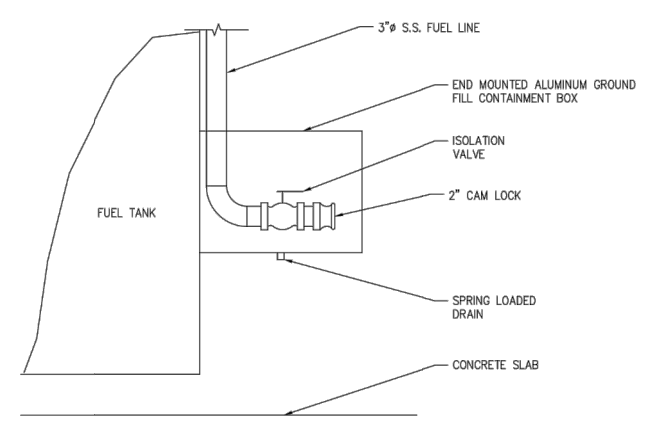

CONTAINMENT BOX DETAIL
 N.T.S.

J.J.F.
 D.W.
 J.J.F.
 J.C.K.

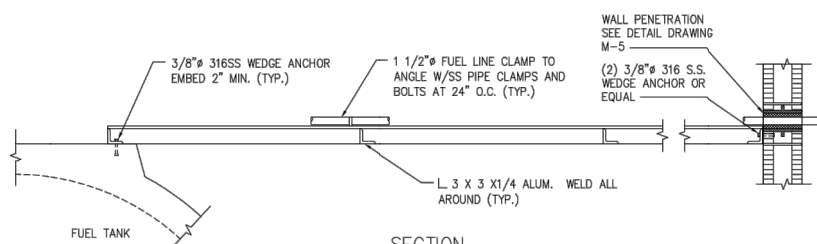
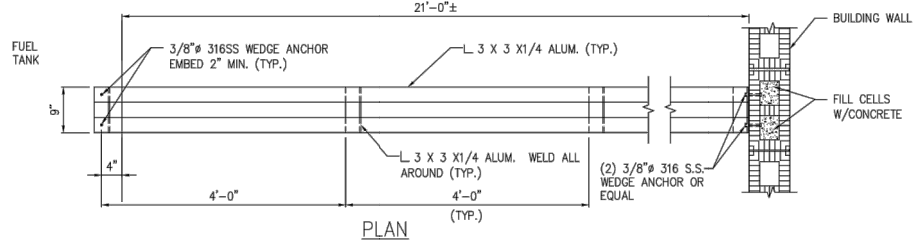

FUEL LINE SUPPORT DETAIL
 3/4"=1'-0"

JOSEPH J. FRANKO P.E.
 No. 48077

AS NOTED

RECORD DRAWING
 1/2008

40707-002-M08

EXISTING ASBUILT BOOSTER PUMP STATION TANK

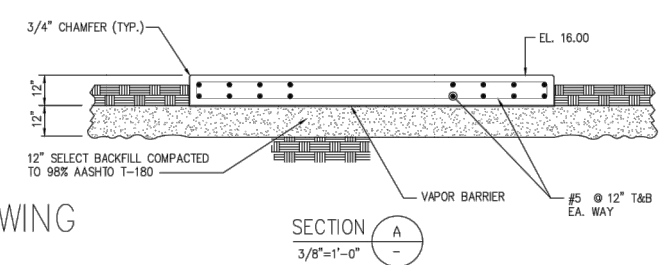

SECTION A
 3/8"=1'-0"

- PLATFORM NOTES:
 1. ALL FRAMING MATERIALS, STRUCTURAL SHAPES, CLIP ANGLES, ETC. SHALL BE OF ALUMINUM TYPE 6061-T6 CONSTRUCTION, MILL FINISH.
 2. ALL FASTENERS, NUTS, BOLTS, WASHERS, ANCHORING DEVICES, ETC. SHALL BE OF TYPE 316 STAINLESS STEEL.
 3. ALL DIMENSIONS SHALL BE FIELD MEASURED AND VERIFIED AFTER EQUIPMENT INSTALLATION, AND PRIOR TO SHOP DRAWING, AND FABRICATION OF PLATFORM.

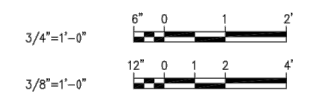

FUEL STORAGE TANK PLAN, FOUNDATION AND DETAILS

17

M-8

SHEET DATA

DATE	
BY	
DESIGNED	
DRAWN	
APPROVED	
CAD FILE NAME	

REVISIONS

NO.	DATE	BY	DESCRIPTION

CALL US FOR SERVICE
 YOU OR ANY OTHER
 ENGINEER THAT YOU CALL
 OF FLORIDA, INC.
 1111
 800 NUMBER TO BE
 800-368-7828
 800-368-7828

CITY OF PORT ST. LUCIE
 UTILITY SYSTEMS DEPARTMENT
 900 S.E. OGDEN LANE
 PORT ST. LUCIE, FL 34983
 PHONE (772) 873-6400 FAX (772) 873-6433



CITY OF PORT ST. LUCIE
 UTILITY SYSTEMS DEPARTMENT
 SOUTH PORT DIESEL TANK REPLACEMENT
 EXISTING ASBUILT BOOSTER PUMP STATION TANK

KNOW WHAT'S BELOW
 ALWAYS CALL 811
 BEFORE YOU DIG
 It's free. It's fast. It's the law.
 www.call811.com



SHEET
 ASBUILT



(FIG. 7, 8, 9, 10, and 11) Remove and dispose of existing 300 gallon day tank, existing fuel supply pipes, and fuel return pipes. Remove and dispose of existing electrical conduits & wiring (with exception of fuel sensor blue box and existing generator) in Southport WWTP generator building.



(FIG. 7, 8, 9, 10, and 11) Remove and dispose of existing 300 gallon day tank, existing fuel supply pipes, and fuel return pipes. Remove and dispose of existing electrical conduits & wiring (with exception of fuel sensor blue box and existing generator) in Southport WWTP generator building.

SHEET DATA	
DESIGNED	DATE
DRAWN	
APPROVED	
CAD FILE NAME	

CITY OF PORT ST. LUCIE
UTILITY SYSTEMS DEPARTMENT
900 S.E. OGDEN LANE
PORT ST. LUCIE, FL 34983
 PHONE (772) 873-6400 FAX (772) 873-6433



CITY OF PORT ST. LUCIE
UTILITY SYSTEMS DEPARTMENT
SOUTH PORT DIESEL TANK REPLACEMENT
WWTP EXISTING TANKS

KNOW WHAT'S BELOW
 ALWAYS CALL 811
 BEFORE YOU DIG
 It's free. It's fast. It's the law.
 www.call811online.com

811
 CALL BEFORE YOU DIG
 www.call811online.com

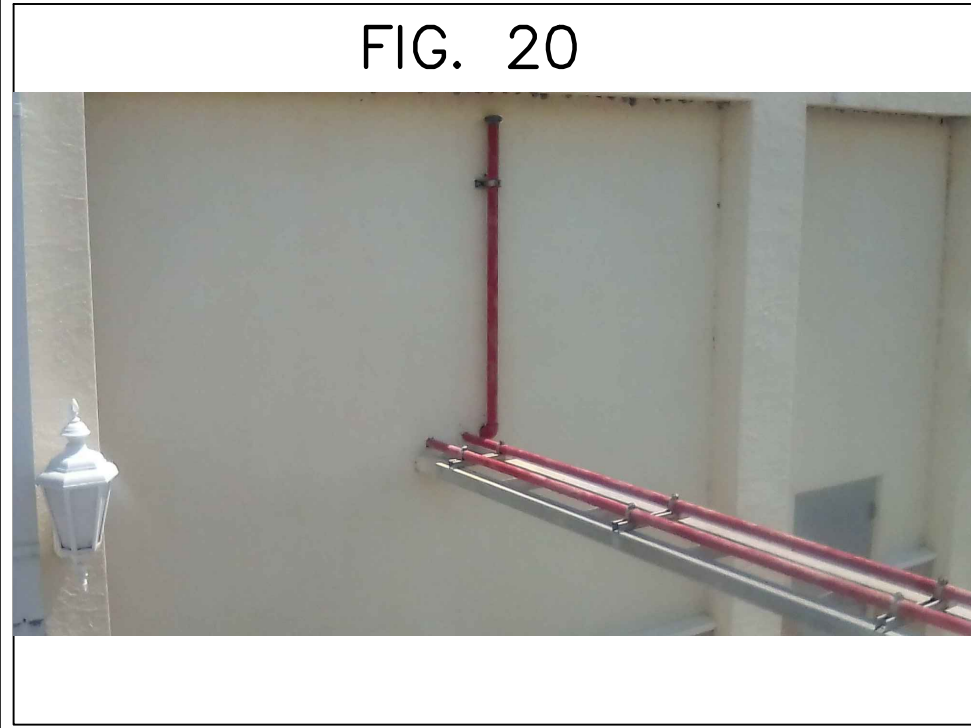

(FIG. 20 and 23) Existing fuel lines support railing.



<p>KNOW WHAT'S BELOW ALWAYS CALL 811 BEFORE YOU DIG It's free. It's fast. It's the law. www.call811sunshine.com</p>		<p>811 CALL 811 FOR ALL DIGGING PROJECTS IN FLORIDA REGULATED BY THE FLORIDA DEPARTMENT OF TRANSPORTATION AND CONSTRUCTION</p>																																									
<p>SHEET 4</p>																																											
<p>CITY OF PORT ST. LUCIE UTILITY SYSTEMS DEPARTMENT 900 S.E. OGDEN LANE PORT ST. LUCIE, FL 34983 PHONE (772) 873-6400 FAX (772) 873-6433</p>																																											
<p>REVISIONS</p> <table border="1"> <tr> <th>NO.</th> <th>DATE</th> <th>BY</th> <th>DATE</th> </tr> <tr> <td> </td> <td> </td> <td> </td> <td> </td> </tr> <tr> <td> </td> <td> </td> <td> </td> <td> </td> </tr> <tr> <td> </td> <td> </td> <td> </td> <td> </td> </tr> <tr> <td> </td> <td> </td> <td> </td> <td> </td> </tr> <tr> <td> </td> <td> </td> <td> </td> <td> </td> </tr> <tr> <td> </td> <td> </td> <td> </td> <td> </td> </tr> <tr> <td> </td> <td> </td> <td> </td> <td> </td> </tr> <tr> <td> </td> <td> </td> <td> </td> <td> </td> </tr> <tr> <td> </td> <td> </td> <td> </td> <td> </td> </tr> </table>				NO.	DATE	BY	DATE																																				
NO.	DATE	BY	DATE																																								
<p>CITY OF PORT ST. LUCIE UTILITY SYSTEMS DEPARTMENT 900 S.E. OGDEN LANE PORT ST. LUCIE, FL 34983 PHONE (772) 873-6400 FAX (772) 873-6433</p>																																											
<p>CITY OF PORT ST. LUCIE UTILITY SYSTEMS DEPARTMENT SOUTH PORT DIESEL TANK REPLACEMENT BOOSTER PUMP STATION TANK</p>																																											

FIG. 25

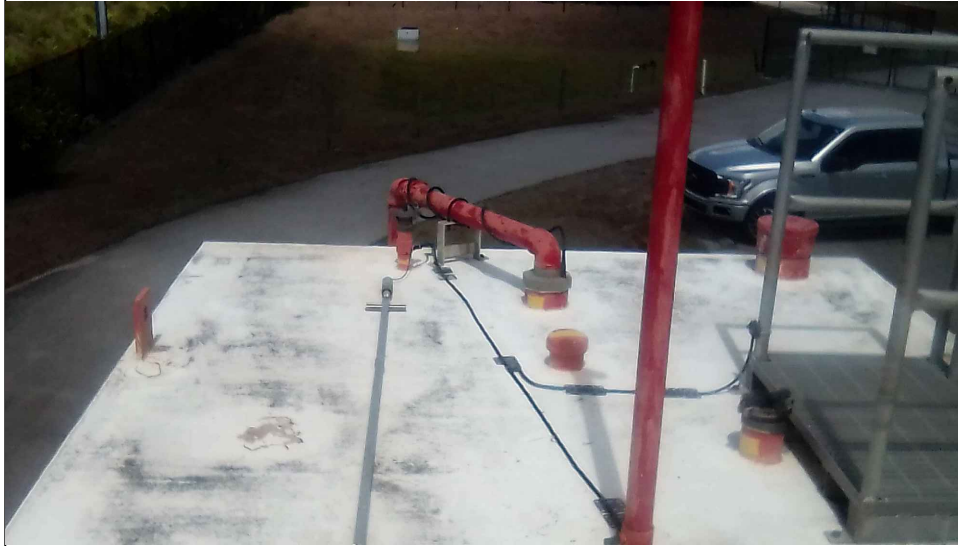

FIG. 26



FIG. 27



(FIG. 27, 28, and 29) Existing sensor.

FIG. 28



FIG. 29



FIG. 30



DATE	BY	REVISIONS

DESIGNED	DATE	BY
DRAWN		
CHECKED		
APPROVED		
CAD FILE NAME		

CALL OR VISIT US ONLINE
 YOU CAN GET OUR SERVICE
 FROM ANYWHERE!
 SUNSHINE STATE PANEL CALL
 SERVICE, INC.
 10000 W. UNIVERSITY BLVD.
 SUITE 100
 BOCA RATON, FL 33433
 WWW.SUNSHINESTATEPANEL.COM

CITY OF PORT ST. LUCIE
UTILITY SYSTEMS DEPARTMENT
900 S.E. OGDEN LANE
PORT ST. LUCIE, FL 34983
PHONE (772) 873-6400 FAX (772) 873-6433



CITY OF PORT ST. LUCIE
UTILITY SYSTEMS DEPARTMENT
SOUTH PORT DIESEL TANK REPLACEMENT
BOOSTER PUMP STATION TANK

KNOW WHAT'S BELOW
 ALWAYS CALL 811
 BEFORE YOU DIG
 It's free. It's fast. It's the law.
 www.call811sunshine.com

E-BID #20220028
 Remove & Replace 8,000 Gallon Diesel Fuel Tank at Southport Booster Station
 Cost Worksheet - Schedule A
 Attachment C

Company Name: _____

Line #	Description	Unit	Qty	Unit Price	Total Amount
1	Furnish all labor, materials and equipment to install 2500 gallons above ground double wall-fire guard temporary standby diesel fuel tank on the Booster pump Station site including all the necessary supply and return piping system connection to existing 250 gallons day tank and all the appurtenance and permitting requirements (during replacement of existing 8000 gallons tank). Diesel fuel supplied by the City.	LS	1		\$ -
2	Furnish all labor, materials and equipment to remove & transport 4000 gallons diesel fuel from existing 8000 gallons tank at Southport Booster Pump Station to Glades Booster pump station and remaining 2500 gallons to be stored in temporary standby tank at the site including pressure clean inside of existing 8000 gallons tank and two fuel piping lines at Southport Booster Pump Station prior to removal and dispose away from the site.	LS	1		\$ -
3	Furnish all labor, materials and equipment to remove & dispose away existing 8000 Gallons above ground Tank and two supply & return pipes (from 8000 gallons tank to a day tank), steel-aluminum ladder & platform, disconnecting-removal & disposal of electrical panels-wirings-conduits, junction boxes at Southport Booster Pump Station.	LS	1		\$ -
4	Furnish all labor, materials and equipment to remove & dispose away existing 2500 Gallons above ground diesel fuel tank and 300 gallons day tank (from 2500 gallons tank to 300 gallons day tank-generator).two above ground-underground supply and return pipes, steel-aluminum ladder & platform, disconnecting-removal & disposal of electrical panels-wirings-conduits, junction boxes from Southport WWTP site Including drilling Four (4) 4-inch diameter holes on existing concrete containment wall at WWTP site.	LS	1		\$ -
5	Furnish all labor, materials and equipment to Install new 8000 gallons above ground fireguard diesel fuel cylindrical tank on existing 12" Thick Concrete Pad including two (2) 1 1/2" steel A53 piping supply & return fuel piping lines (from new 8000 gallons tank to a day tank inside generator's building), aluminum platform-handrail-stairs-ladder and support aluminum fuel line support railing, including applying and obtaining all the necessary City, FDEP and Palm Beach County Resource management Permitting Requirements and all the appurtenance.	LS	1		\$ -
6	Furnish all labor, materials and equipment to install new electrical panels with breaker, junction boxes, electrical wirings, communication wirings, 5G Cellular communication, and sensors required for a new 8000 gallons diesel fuel tank, including applying and obtaining all the necessary City, FDEP and Palm Beach County Permitting Requirements and all the appurtenance.	LS	1		\$ -
				TOTAL	\$ -

Contractor Signature: _____
 Contractor's Name: _____
 Contractor's Phone Number: _____
 Contractor's Email Address: _____

CITY OF PORT ST. LUCIE
SAMPLE CONTRACT
(DO NOT EXECUTE-TERMS MAY CHANGE DUE TO CONTRACTOR'S RESPONSE)

This Contract, executed this _____ day of _____, 2022, by and between the CITY OF PORT ST. LUCIE, FLORIDA, a municipal corporation, duly organized under the laws of the State of Florida, hereinafter called "City", and _____, hereinafter called "Contractor" or "Proposer".

SECTION I
RECITALS

In consideration of the below agreements and covenants set forth herein, the parties agree as follows:

WHEREAS, Contractor is licensed in the State of Florida; and

WHEREAS, the City wishes to contract with a Contractor to provide the Scope of Services and products / services based on the terms and subject to the conditions contained herein; and

WHEREAS, Contractor is qualified, willing, and able to provide the Scope of Services and products / services specified on the terms and conditions set forth herein; and

WHEREAS, the City desires to enter into this Contract with Contractor to perform the Scope of Services and product / services specified and, with a commission amount to be paid as agreed upon below.

NOW THEREFORE, in consideration of the premises and the mutual covenants herein name, the Parties agree as follows:

The Recitals set forth above are hereby incorporated into this Contract and made a part of hereof for reference.

SECTION II
NOTICES

All notices or other communications hereunder shall be in writing and shall be deemed duly given if delivered in person, sent by certified mail with return receipt request, email or fax and addressed as follows unless written notice of a change of address is given pursuant to the provisions of this Contract.

Contractor: TBD

City Contract Administrator: Michelle Fentress
Procurement Agent I - Procurement Management Department
121 SW Port St. Lucie Boulevard
Port St. Lucie, FL 34984-5099
772-871-5222 / FAX 772-871-7337
E-mail: mfentress@cityofpsl.com

City Project Manager: Karim Rahmankhah, P.E.
Utility Systems Dept.

City of Port St. Lucie
900 SE Ogden Lane
Port St. Lucie, FL 34952
Telephone 772-873-6485
Email: krahmankhah@cityofpsl.com

SECTION III

DESCRIPTION OF SERVICES

Furnish all labor, equipment, and materials to remove and replace the existing 8000-gallon above ground diesel fuel tank (including fuel piping lines to existing day tank) at the Southport Booster Pump Station, remove and legally dispose of the existing 2500-gallon above ground diesel fuel tank & 300-gallon diesel fuel day tank. Work will also include the removal of all above ground & underground fuel piping lines that connect to the 2500-gallon and 300-gallon fuel tanks at Southport WWTP.

The work also includes:

- Applying and obtaining all the necessary City, FDEP and Palm Beach County Resource Management Permitting Requirements.
- Remove and transport approximately 4000 gallons of diesel fuel from existing 8000-gallon above ground tank at Southport Booster Pump Station to Glades Booster Pump station. The remaining 2500 gallons of diesel fuel is to be stored in a temporary standby storage tank (supplied by the Contractor) during the replacement of the existing 8000-gallon above ground tank. The existing diesel fuel supply & return piping (from existing 8000-gallon tank to a day tank inside generator room) is to be removed and legally dispose of from the site after both pipes have been cleaned in accordance with FDEP and Palm Beach County Resource Management Closure Permitting requirement by the contractor.
- The Existing above ground & underground fuel supply & return piping from the 2500-gallon tank to the 300-gallon day tank to a Generator (inside generator building), must be removed and legally disposed of at Southport WWTP.
- The Contractor is responsible for the removal of existing diesel fuel by transporting and disposing of biohazardous wastes produced during the cleaning and demolition process of the existing 8000-gallon tank, 2500-gallon tank and 300-gallon day tank at Southport Booster Pump Station and WWTP.
- Remove and dispose of the existing 8000-gallon above ground diesel fuel tank at booster pump stations, the 300-gallon day tank at Southport WWTP and the 2500-gallon above ground tank including the complete restoration of both sites.
- The Contractor is responsible for installing a 2500-gallon above ground double wall-fire guard temporary standby diesel fuel tank at the Booster Pump Station site including all the necessary

supply & return pipes, connections to the existing 250-gallon day tank & all the accessories (during replacement of existing 8000-gallon tank). Diesel fuel will be supplied by the City.

- The Contractor may use the Booster Pump Station site to demolish the concrete encasement of the existing above ground 8000-gallon diesel fuel tank prior to its removal & disposal. Demolished concrete materials must be removed and legally dispose of including complete restoration.
- The existing 8000-gallon above ground tank fuel lines steel-aluminum support railing, steel-aluminum ladder & catwalk must be disassembled at the site and return to the City.
- The existing 8000-gallon tank's 12" thick reinforced concrete pad and existing concrete bollards must be protected at all times during construction. The Contractor is responsible for repair and replacement of any damages to the existing 12" thick concrete pad and concrete bollards during demolishing, removal and disposal of existing 8000-gallon tank.
- The existing electrical panels, junction boxes, wirings, communication wiring and sensors must always be protected during the removal of the existing 8000-gallon tank and it may be used to connect to a new 8000-gallon diesel fuel tank pending the tank's manufacturer recommendation. Any new required installation of electrical panels with breaker, junction boxes, electrical wirings, communication wirings, 5G Cellular communication, and sensors for a new 8000-gallon diesel fuel tank will be paid separately.
- The Contractor is responsible to drill four (4) 4" diameter holes on the existing concrete containment wall to drain all rainwater onto the surrounding field at Southport WWTP. The cost should be included in the 2500-gallon above ground diesel fuel tank and 300- gallon day tank removal and disposal.
- The new 8000-gallon above ground fireguard diesel fuel tank should be a cylindrical and horizontal steel tank welded on two (2) saddles with an inner-primary and outer-secondary tank. The tank should be a minimum of ¼" steel thickness for the shell and heads of both inner and outer tanks, filled with 6" thick lightweight monolithic thermal material insulation (between primary and secondary tank) per standards specifications of UI 2085, UI142, UI 567 and NFPA 30. It should also have leak detection, level control and other accessories, aluminum platform and aluminum side mount ladder from the stair base slab to the top of the tank. It should include aluminum stairs, aluminum handrail alloy 6061, grating and appurtenances.
- The new 8000-gallon above ground fireguard diesel fuel tank should have continuous weld on all sides per UI 142, reinforce threaded openings or flanges for all pipe connections, including fill, supply, electronic fuel level sensor, internal monitoring port, vents, and manholes., All threaded openings shall be seamless black steel, schedule 40, conforming to ASTM A53, malleable iron, ANSI B16.3, Class 150.
- The new 8000-gallon above ground fireguard diesel fuel tank should have an emergency vent per NFPA 30 requirement. It should have a cast iron cover with a non-sparking O-ring gasket for relief of tank pressure. The emergency vent should be an 8" diameter MORR Model 244 or equivalent. It

should also have a 24" diameter bolted manhole. The steel tank shall be pressurized at the casting facility and tested per UI 142 requirement. It should also have a two-hour fire wall as required by Uniform Fire Code. The outer surface of the steel tank should be coated with a rust proofing exterior oxide coating with finish painting of white urethane paint system on the shell and heads. The two (2) 1½" supply and return steel pipes should be painted red.

- The new 8000-gallon above ground fireguard diesel fuel tank should have a 3" x 4" vapor recovery adaptor OPW model 1711T or approved equivalent. It should have overfilled protection to prevent overfilling and to prevent excess pressure. These systems should include both automatic and manual shutoff or approved equivalent. The overfill prevention systems shall include ground fill application with a 3" overfill prevention valve C&B model 1228-F-35, ball valve MORR model 691 and a dry-break disconnect with dust cap, OPW Model 1612AN and OPW Model 634B respectively or equivalent. The tank fill shall be enclosed in a seven (7) gallon lockable aluminum containment box. The tank fill piping shall be type 304 stainless steel and it should have a 2" diameter pipe with vent and screen above the top of the tank OPW Model 230033. The tank's interstitial vent should be OPW model 155. It should have a complete fuel monitoring and inventory measurement system Model TLS-300 C-4 as manufactured by Veeder-Root or equivalent. The system should be equipped to monitor the 8000-gallon diesel fuel storage tank. The unit shall be equipped with magnetostrictive probes for fuel inventory measurement, interstitial leak sensor and Ethernet-TCP/IP communication card for (LAN/WAN) connection.
- The new 8000-gallon above ground fireguard diesel fuel tank should have a 3" diameter fill line type 304 stainless steel equipped with a lockable drip box, an isolation ball valve, and a quick connect cam-lock coupling. The drip box shall be a minimum of 2'x 2'x 2' deep and should have a spring-loaded drain plugin the bottom. It should also include 1½" foot valves on the fuel supply line and 1½" isolation ball valves on the supply and return line. All hardware and anchor bolts shall be type 316 stainless steel.
- The new 8000-gallon above ground fireguard diesel fuel tank shall be installed on top of the existing 12" thick reinforce concrete slabs (as shown on the as-built drawing) with four (4) ¾" stainless steel anchor bolts embedded five (5) inches into the concrete. The Contractor shall field paint the fuel tank entirely after installation is completed. Surface preparation shall be in accordance with factory paint system (including providing appropriate labels for tank).
- The Contractor shall provide all fuel required for startup of the emergency generator system. Upon satisfactory operational demonstration of the emergency generator system, the Contractor shall provide 3000 gallons of no.2 diesel fuel. The diesel fuel shall contain all additives required by the emergency generator system.
- The new 8000-gallon above ground diesel fuel tank shall have a qualified manufacturer's technical representative who shall adequately supervise the installation of the diesel fuel tank. The services of the manufacturer's representative shall be provided for a period not less than three (3) days; one trip of two (21 days during installation of the tank), and one trip of (one day after acceptance of the tank to instruct the owner's personnel in the proper operation and maintenance of the tank).

- The new 8000-gallon above ground diesel fuel tank shall have a 30-year warranty from the tank's manufacturer. The Contractor shall be responsible for the delivery, handling, storage and hauling of the diesel fuel tank to the site. The Manufacturer shall furnish all special tools necessary for services, repairs, and adjustments of the 8000-gallon above ground fireguard diesel fuel tank.
- The new 8000-gallon diesel fuel tank and appurtenance should be Ecovault inc, ConVault Florida, Armocast, Envirosafe and Highland Tank or an approved equivalent.
- The Contractor must complete the entire work (removal and disposal of three (3) fuel tanks, piping, temporary standby tank and installation of one (1) new 8000-gallon above ground diesel tank, supply and return piping, fittings, painting, electrical wirings, sensors, all accessories and all the appurtenance) within **21 business days after** receiving the new above ground 8000 gallons fireguard diesel fuel tank.

SECTION IV
TIME OF PERFORMANCE

The Contract Period start date will be _____ and will terminate twenty-one (21) calendar days thereafter on _____. The Contractor will be required to commence work under this Contract within ten (10) calendar days after the start date identified in this Contract. In the event all work required in the bid specifications has not been completed by the specified date, the Contractor agrees to provide work as authorized by the Project Manager until all work specified in the bid specifications has been rendered and accepted by the City.

Written requests shall be submitted to the Project Manager for consideration of extension of completion time due to strikes, unavailable materials, or other similar causes over which the Contractor feels he has no control. Requests for time extensions shall be submitted immediately but in no event more than two (2) weeks upon occurrence of conditions, which, in the opinion of the contractor, warrant such an extension with reasons clearly stated and a detailed explanation given as to why the delays are considered to be beyond the Contractor's control.

SECTION V
RENEWAL OPTION

This section will not be utilized in this contract.

SECTION VI
COMPENSATION

The total amount to be paid by the City to the Contractor is on a lump sum basis listed on Schedule "A" for a total amount of \$_____. Payments will be disbursed in the following manner:

The Contract Sum - Work to be paid for on the basis of per unit prices: each, lump sum, linear feet, square yards, system, etc.

Progress Payments- Within twenty (20) business days, the City shall pay the Contractor, the sum of money due each Progress Payment that is properly allocated to labor, materials and equipment incorporated in the work for the period covered in the application for progress payment. Retainage will be held at 5% from each progress payment.

Acceptance and Final Payment - Upon receipt of written notice that the work is ready for final inspection and acceptance, the City will promptly make such inspection. When City finds the work acceptable under the terms of the Contract and the Contract is fully performed the entire balance will be due the Contractor and will be paid to the Contractor within twenty (20) business days. Such final payment to the Contractor shall be subject to the covenants in the Contract's Standard Specifications and any liquidated damages will be assessed against the Contractor at that time.

Before issuance of final payment, the Contractor shall submit evidence that all payrolls, material bills and other indebtedness connected with the work have been satisfied and paid in full. Final Release of Liens from all contractors, subcontractors, suppliers for materials and sub-subcontractors are to be attached to the final invoice. In lieu of Final Releases, the Contractor may submit a Consent of Surety with the final invoice. All manufacturer's warranty documents must be provided in the format requested by the City prior to final payment.

Invoices for services shall be submitted once a month, by the tenth (10th) day of each month, and payments shall be made within twenty (20) business days unless Contractor has chosen to take advantage of the Purchasing Card Program, which guarantees payment within several days. Payments shall be made within twenty (20) business days of receipt of Contractor's valid invoice, provided that the invoice is accompanied by adequate supporting documentation, including any necessary partial release of liens as described above, and is approved by the Project Manager as required under Section XV of the Contract.

No payment for projects involving improvements to real property shall be due until Contractor delivers to City a complete release of all claims arising out of the contract or receipts in full in lieu thereof, and an affidavit on his personal knowledge that the releases and receipts include labor and materials for which a lien could be filed.

All invoices and correspondence relative to this Contract must contain the City's Contract number and Purchase Order number, detail of items with prices that correspond to the Contract, a unique invoice number and partial and final release of liens.

All invoices are to be sent to: APNOTIFICATIONS@CITYOFPSL.COM and the assigned Project Manager for this Contract.

The Contractor shall not be paid additional compensation for any loss or damage, arising out of the nature of the work, from the action of the elements, or from any delay or unforeseen obstruction or difficulties encountered in the performance of the work, or for any expenses incurred by or in consequence of the suspension or discontinuance of the work.

In the event the City deems it expedient to perform work which has not been done by the Contractor as required by these Specifications, or to correct work which has been improperly and/or inadequately performed by the Contractor as required in these Specifications, all expenses thus incurred by the City, at

the City's option, will be invoiced to the Contractor and/or deducted from payments due to the Contractor. Deductions thus made will not excuse the Contractor from other penalties and conditions contained in the Contract.

All payments not made within the time specified by this section shall bear interest from 30 calendar days after the due date at the rate of one (1) percent per month on the unpaid balance.

Taxes. Contractor is responsible for all federal, state, and local taxes and other charges related to the performance of this contracts.

SECTION VII **WORK CHANGES**

The City reserves the right to order work changes in the nature of additions, deletions or modifications without invalidating the Contract, and agrees to make corresponding adjustments in the contract price and time for completion. Any and all changes must be authorized by a written change order signed by the City's Purchasing Agent or his designee as representing the City. Work shall be changed and the contract price and completion time shall be modified only as set out in the written change order. Any adjustment in the contract price resulting in a credit or a charge to the City shall be determined by mutual agreement of the parties before starting the work involved in the change. Any dispute concerning work changes which is not resolved by mutual agreement shall be decided by the City Manager who shall reduce the decision to writing. The decision of the City shall be final and conclusive.

SECTION VIII **CONFORMANCE WITH PROPOSAL**

It is understood that the materials and/or work required herein are in accordance with the proposal made by the Contractor pursuant to the Solicitation and Specifications on file in the Procurement Management Department of the City. All documents submitted by the Contractor in relation to said proposal, and all documents promulgated by the City for inviting proposals are, by reference, made a part hereof as if set forth herein in full.

SECTION IX **INDEMNIFICATION/HOLD HARMLESS**

Contractor agrees to indemnify, defend and hold harmless, the City, its officers, agents, and employees from, and against any and all claims, actions, liabilities, losses and expenses including, but not limited to, attorney's fees for personal, economic or bodily injury, wrongful death, loss of or damage to property, at law or in equity, which may arise or may be alleged to have risen from the negligent acts, errors, omissions or other wrongful conduct of Contractor, agents, laborers, subcontractors or other personnel entity acting under Contractor control in connection with the Contractor's performance of services under this Contract and to that extent Contractor shall pay such claims and losses and shall pay all such costs and judgments which may issue from any lawsuit arising from such claims and losses including wrongful termination or allegations of discrimination or harassment, and shall pay all costs and attorney's fees expended by the City in defense of such claims and losses including appeals. That the aforesaid hold-harmless Contract by Contractor shall

apply to all damages and claims for damages of every kind suffered, or alleged to have been suffered, by reason of any of the aforesaid operations of Contractor or any agent laborers, subcontractors or employee of Contractor regardless of whether or not such insurance policies shall have been determined to be applicable to any of such damages or claims for damages. Contractor shall be held responsible for any violation of laws, rules, regulations or ordinances affecting in any way the conduct of all persons engaged in or the materials or methods used by Contractor on the work. This indemnification shall survive the termination of this Contract.

SECTION X **SOVEREIGN IMMUNITY**

Nothing contained in this Contract shall be deemed or otherwise interpreted as waiving the City's sovereign immunity protections existing under the laws of the State of Florida, or as increasing the limits of liability as set forth in [Section 768.28, Florida Statutes](#).

SECTION XI **INSURANCE**

The Contractor shall, on a primary basis and at its sole expense, agree to maintain in full force and effect at all times during the life of this Contract, insurance coverage, limits, including endorsements, as described herein. The requirements contained herein, as well as City's review or acceptance of insurance maintained by Contractor are not intended to and shall not in any manner limit or qualify the liabilities and obligations assumed by Contractor under the Contract.

The parties agree and recognize that it is not the intent of the City of Port St. Lucie that any insurance policy/coverage that it may obtain pursuant to any provision of this Contract will provide insurance coverage to any entity, corporation, business, person, or organization, other than the City of Port St. Lucie and the City shall not be obligated to provide any insurance coverage other than for the City of Port St. Lucie or extend its sovereign immunity pursuant to Section 768.28, Florida Statutes, under its self-insured program. Any provision contained herein to the contrary shall be considered void and unenforceable by any party. This provision does not apply to any obligation imposed on any other party to obtain insurance coverage for this project, any obligation to name the City of Port St. Lucie as an additional insured under any other insurance policy, or otherwise protect the interests of the City of Port St. Lucie as specified in this Contract.

1. Workers' Compensation Insurance & Employer's Liability: The Contractor shall agree to maintain Workers' Compensation Insurance & Employers' Liability in accordance with Section 440, Florida Statutes. Employers' Liability and must include limits of at least \$100,000.00 each accident, \$100,000.00 each disease/employee, \$500,000.00 each disease/maximum. A Waiver of Subrogation endorsement shall be provided. Coverage shall apply on a primary basis. Should scope of work performed by Contractor qualify its employee for benefits under Federal Workers' Compensation Statute (example, U.S. Longshore & Harbor Workers Act or Merchant Marine Act), proof of appropriate Federal Act coverage must be provided.
2. Commercial General Liability Insurance: The Contractor shall agree to maintain Commercial General Liability insurance issued under an Occurrence form basis, including Contractual liability, to cover the hold harmless agreement set forth herein, with limits of not less than:

Each occurrence	\$1,000,000
Personal/advertising injury	\$1,000,000
Products/completed operations aggregate	\$2,000,000
General aggregate	\$2,000,000
Fire damage	\$100,000 any 1 fire
Medical expense	\$10,000 any 1 person

- Additional Insured: An Additional Insured endorsement **must** be attached to the certificate of insurance and must include coverage for on-going and Completed Operations (should be ISO **CG2037 & CG2010**) under the General Liability policy. Products & Completed Operations coverage to be provided for a minimum of five (5) years from the date of possession by City or completion of contract. Coverage is to be written on an occurrence form basis. Coverage shall apply on a primary and non-contributory basis. A per project aggregate limit endorsement should be attached. Defense costs are to be in addition to the limit of liability. A waiver of subrogation shall be provided in favor of the City. Coverage for the hazards of explosion, collapse and underground property damage (XCU) must also be included when applicable to the work performed. No exclusion for mold, silica or respirable dust or bodily injury/property damage arising out of heat, smoke, fumes, or hostile fire shall apply. Coverage shall extend to independent contractors and fellow employees. Contractual Liability is to be included. Coverage is to include a cross liability or severability of interests provision as provided under the standard ISO form separation of insurers clause.

Except as to Workers' Compensation and Employers' Liability, said Certificate(s) and policies shall clearly state that coverage required by the Contract has been endorsed to include the City of Port St. Lucie, a municipality of the State of Florida, its officers, agents and employees as Additional Insured added to its Commercial General Liability policy and Business Auto policy. The name for the Additional Insured endorsement issued by the insurer shall read **"City of Port St. Lucie, a municipality of the State of Florida, its officers, employees and agents and shall include Contract #20220028 – Remove & Replace 8,000 Gallon Diesel Fuel Tank @ Southport Booster Station Project be listed as additionally insured."** The Policies shall be specifically endorsed to provide thirty (30) day written notice to the City prior to any adverse changes, cancellation, or non-renewal of coverage thereunder. In the event that the statutory liability of the City is amended during the term of this Contract to exceed the above limits, the Contractor shall be required, upon thirty (30) days written notice by the City, to provide coverage at least equal to the amended statutory limit of liability of the City. Copies of the Additional Insured endorsements including Completed Operations coverage shall be attached to the Certificate of Insurance.

- Automobile Liability Insurance: The Contractor shall agree to maintain Business Automobile Liability at a limit of liability not less than \$1,000,000.00 each accident covering any auto, owned, non-owned and hired automobiles. In the event, the Contractor does not own any automobiles; the Business Auto Liability requirement shall be amended allowing Contractor to agree to maintain only Hired & Non-Owned Auto Liability. This amended requirement may be satisfied by way of endorsement to the Commercial General Liability, or separate Business Auto Coverage form. Certificate holder must be listed as additional insured. A waiver of subrogation shall be provided. Coverage shall apply on a primary non-contributory basis.

5. Pollution Insurance: Contractor shall procure and agree to maintain in full force during the term of this Agreement, Pollution Liability Insurance in limits not less than \$1,000,000 per occurrence, \$2,000,000 aggregate, for any operations relating to the handling, storage, and transportation of hazardous materials and/or waste. The City of Port St. Lucie shall be listed as an additional insured. A waiver of subrogation shall be provided in favor of the City. Coverage shall apply on a primary and non-contributory basis.
6. Waiver of Subrogation: The Contractor shall agree by entering into this Contract to a Waiver of Subrogation for each required policy. When required by the insurer, or should a policy condition not permit an Insured to enter into a pre-loss Contract to waive subrogation without an endorsement then Contractor shall agree to notify the insurer and request the policy be endorsed with a Waiver of Transfer of Rights of Recovery Against Others, or its equivalent. This Waiver of Subrogation requirement shall not apply to any policy where a condition to the policy specifically prohibits such an endorsement, or voids coverage should Contractor enter into such a Contract on a pre-loss basis.
7. Deductibles: All deductible amounts shall be paid for and be the responsibility of the Contractor for any and all claims under this Contract. Where an SIR or deductible exceeds \$5,000, the City of Port St. Lucie reserves the right, but not obligation, to review and request a copy of the bidder's most recent annual report or audited financial statement.

It shall be the responsibility of the Contractor to ensure that all independent contractors and/subcontractors comply with the same insurance requirements as listed herein, including Products & Completed Operations coverage for a minimum of five (5) years from the date of possession by City or completion of contract. It will be the responsibility of the Contractor to obtain Certificates of Insurance from all contractors and subcontractors listing the City as an Additional Insured, without the language when required by written contract. If contractor, independent contractor or subcontractor maintain higher limits than the minimums shown above, the City requires and shall be entitled to coverage for the higher limits maintained by contractor/independent contractor/subcontractor.

The Contractor may satisfy the minimum limits required above for either Commercial General Liability, Business Auto Liability, or Employers' Liability coverage under Umbrella or Excess Liability. The Umbrella or Excess Liability shall have an Aggregate limit not less than the highest "Each Occurrence" limit for either Commercial General Liability, Business Auto Liability, or Employers' Liability. When required by the insurer, or when Umbrella or Excess Liability is written on Non-Follow Form," the City shall be endorsed as an "Additional Insured."

The City, by and through its Risk Management Department, reserves the right, but not obligation, to review, modify, reject, or accept any required policies of insurance including limits, coverages or endorsements, herein from time to time throughout the term of this contract. All insurance carriers must have an AM Best rating of at least A:VII or better.

A failure on the part of the contractor to execute the contract and/or punctually deliver the required insurance, and other documentation may be cause for annulment of the award.

Payment & Performance Bonds: The Contractor shall furnish an acceptable recorded Performance and Payment Bond complying with the statutory requirements set forth in Section 255.05, Florida Statutes, in the amount of one hundred (100%) percent of the Contract price. A fully authorized Surety, licensed by the State

of Florida shall execute the Performance and Payment Bond. The Performance and Payment Bond shall remain in full force and effect a minimum of one (1) year after the work has been completed and final acceptance of the work is issued by the City.

Should the Surety become irresponsible during the time the Contract is in force, the City may require additional and sufficient sureties and the Contractor shall furnish same to the satisfaction of the City within ten (10) days after written notice to do so. In default thereof, the Contract may be suspended as herein provided.

SECTION XII **ACTS OF GOD**

The Contractor shall be responsible for all preparation of the site for Acts of God, including but not limited to; earthquake, flood, tropical storm, hurricane or other cataclysmic phenomenon of nature, rain, wind or other natural phenomenon of normal intensity, including extreme rainfall. No reparation shall be made to the Contractor for damages to the Work resulting from these Acts. The City is not responsible for any costs associated with pre or post preparations for any Acts of God.

Emergencies – In the event of emergencies affecting the safety of persons, the work, or property, at the site or adjacent thereto, the Contractor, or his designee, without special instruction or authorization from the City, is obligated to act to prevent threatened damage, injury or loss. In the event such actions are taken, the Contractor shall promptly give to the City written notice and contact immediately by phone, of any significant changes in work or deviations from the Contract documents caused thereby, and if such action is deemed appropriate by the City a written authorization signed by the City covering the approved changes and deviations will be issued.

SECTION XIII **PROHIBITION AGAINST FILING OR MAINTAINING LIENS AND SUITS**

Subject to the laws of the State of Florida and of the United States, neither Contractor nor any Sub-Contractor supplier of materials, laborer or other person shall file or maintain any lien for labor or materials delivered in the performance of this Contract against the City. The right to maintain such lien for any or all of the above parties is hereby expressly waived.

SECTION XIV **COMPLIANCE WITH LAWS**

The Contractor shall give all notices required by and shall otherwise comply with all applicable laws, ordinances, and codes and shall, at his own expense, secure and pay the fees and charges for all permits required for the performance of the Contract. All materials furnished and works done are to comply with all federal, state, and local laws and regulations. Contractor will comply with all requirements of [28 C.F.R. § 35.151](#). Contractors and Sub-Contractor, shall comply with [§ 119.0701, Fla. Stat.](#) The Contractor and Sub-Contractor, are to allow public access to all documents, papers, letters, or other material made or received by the Contractor in conjunction with this Contract, unless the records are exempt from [Art. I, § 24\(a\), Fla. Const.](#) and § 119.07(1)(a), Fla. Stat. (2013). Pursuant to [§ 119.10\(2\)\(a\), Fla. Stat.](#), any person who willfully and knowingly violates any of the provisions of Ch. 119, Laws of Fla., commits a misdemeanor of the first degree, punishable as provided in [§ 775.082](#) and [§ 775.083 Fla. Stat.](#)

RECORDS

The City of Port St. Lucie is a public agency subject to Chapter 119, Florida Statutes. The Contractor shall comply with Florida's Public Records Law. CONTRACTOR'S RESPONSIBILITY FOR COMPLIANCE WITH CHAPTER 119, FLORIDA STATUTES. Pursuant to Section 119.0701, F.S.

Contractor agrees to comply with all public records laws, specifically to:

Keep and maintain public records required by the City in order to perform the service;

1. The timeframes and classifications for records retention requirements must be in accordance with the [General Records Schedule GS1-SL for State and Local Government Agencies](#).
2. During the term of the contract, the Contractor shall maintain all books, reports and records in accordance with generally accepted accounting practices and standards for records directly related to this contract. The form of all records and reports shall be subject to the approval of the City.
3. Records include all documents, papers, letters, maps, books, tapes, photographs, films, sound recordings, data processing software, or other material, regardless of the physical form, characteristics, or means of transmission, made or received pursuant to law or ordinance or in connection with the transaction of official business with the City. Contractor's records under this Contract include but are not limited to, supplier/subcontractor invoices and contracts, project documents, meeting notes, emails and all other documentation generated during this Agreement.
4. The Contractor agrees to make available to the City, during normal business hours all books of account, reports and records relating to this contract.
5. A Contractor who fails to provide the public records to the City within a reasonable time may also be subject to penalties under Section 119.10, Florida Statutes.

Upon request from the City's custodian of public records, provide the public agency with a copy of the requested records or allow the records to be inspected or copied within a reasonable time at a cost that does not exceed the cost provided in this chapter or as otherwise provided by law.

Ensure that public records that are exempt or confidential and exempt from public records disclosure requirements are not disclosed except as authorized by law for the duration of the contract term and following completion of the contract if the contractor does not transfer the records to the City.

Upon completion of the contract, transfer, at no cost to the City, all public records in possession of the Contractor, or keep and maintain public records required by the City to perform the service. If the Contractor transfers all public records to the City upon completion of the contract, the Contractor shall destroy any duplicate public records that are exempt or confidential and exempt from public records disclosure requirements. If the Contractor keeps and maintains public records upon completion of the contract, the Contractor shall meet all applicable requirements for retaining public records. All records stored electronically must be provided to the City, upon request from the City's custodian of public records in a format that is compatible with the information technology systems of the City.

IF THE CONTRACTOR HAS QUESTIONS REGARDING THE APPLICATION OF CHAPTER 119, FLORIDA STATUTES, TO THE CONTRACTOR'S DUTY TO PROVIDE PUBLIC RECORDS RELATING TO THIS CONTRACT, CONTACT THE CUSTODIAN OF PUBLIC RECORDS AT:

**CITY CLERK
121 SW Port St. Lucie Blvd.
Port St. Lucie, FL 34984
(772) 871 5157
pr@cityofpsl.com**

**SECTION XV
INSPECTION AND CORRECTION OF DEFECTS**

In order to determine whether the required material has been delivered or the required work performed in accordance with the terms and conditions of the Contract documents, the Project Manager shall make inspection as soon as practicable after receipt from the Contractor of a Notice of Performance or delivery ticket. If such inspection shows that the required material has been delivered and required work performed in accordance with terms and conditions of the Contract documents and that the material and work is entirely satisfactory, the Project Manager shall approve the invoice when it is received. Thereafter the Contractor shall be entitled to payment, as described in Section V. If, on such inspection the Project Manager is not satisfied, he shall as promptly as practicable inform the parties hereto of the specific respects in which his findings are not favorable. Contractor shall then be afforded an opportunity if desired by him, to correct the deficiencies so pointed out at no additional charge to the City, and otherwise on terms and conditions specified by the Project Manager. Upon failure of the Contractor to perform the work in accordance with the Contract Documents, including any requirements with respect to the Schedule of Completion, and after five (5) days written notice to the Contractor, the City may, without prejudice to any other remedy he may have, correct such deficiencies. The Contractor shall be charged all costs incurred to correct deficiencies. Such examination, inspection, or tests made by the Project Manager, at any time, shall not relieve Contractor of his responsibility to remedy any deviation, deficiency, or defect.

Authority - The Contractor is hereby informed that City inspectors are not authorized to alter, revoke, enlarge, or relax the provisions of these specifications. They are not authorized to approve or accept any portion of the completed work, or instructions contrary to the specifications. An inspector is placed on the project (or sent to the location of materials) to inspect materials being used in the work and to observe the manner in which the work is being performed and to report the progress of the work to the City. The inspector shall have the authority to reject defective materials or suspend any work that is being improperly done subject to the final decision of the City.

Notification – The Contractor shall be responsible to give twenty-four (24) hour notification to the City, when field observations are required.

Defective Work - All work and/or materials not meeting the requirements of these specifications shall be deemed as defective by the City, and all such work and/or material, whether in place or not, shall be removed immediately from the site of the work. All rejected materials that have been corrected shall not be used until

the City has issued written approval to the Contractor. Without unnecessary delay and without any additional cost to the City, all work that has been rejected shall be remedied or removed and replaced in a manner acceptable to the City. If the Contractor fails to promptly remove and properly dispose of rejected materials and/or work then replaces same immediately after being notified to do so, the City may employ labor to remove and replace such defective work and/or materials. All charges for replacement of defective materials and/or work shall be charged to the Contractor and may be deducted from any moneys due to the Contractor or his Surety.

Repair or Replacement - Should any defect appear during the warranty period, the Contractor shall, at their own expense, have repaired or replaced such item upon receipt of written notice from the City of said defect. Said repair or replacement must be accomplished within fourteen (14) calendar days after receipt of notification from the City of the defect.

Deductions - In the event the City deems it expedient to perform work which has not been done by the Contractor as required by these Specifications, or to correct work which has been improperly and/or inadequately performed by the Contractor as required in these Specifications, all expenses thus incurred by the City, in the City's option, will be invoiced to the Contractor and/or may be deducted from payments due to the Contractor. Deductions thus made will not excuse the Contractor from other penalties and conditions contained in the Contract.

SECTION XVI **SCRUTINIZED COMPANIES**

[Section 287.135, Florida Statutes](https://www.sbafla.com/fsb/Portals/FSB/Content/GlobalGovernanceMandates/QuarterlyReports/Global_Governance_Mandates_and_Florida%20Statutes_2019_01_29.pdf?ver=2019-01-29-130006-790), prohibits agencies from contracting with companies, for goods or services over \$1,000,000 that are on either the Scrutinized Companies with Activities in Sudan List or the Scrutinized Companies with Activities in the Iran petroleum Energy Sector List, or do any business with Cuba or Syria. Both lists are created pursuant to [Section 215.473, Florida Statutes](https://www.sbafla.com/fsb/Portals/FSB/Content/GlobalGovernanceMandates/QuarterlyReports/Global_Governance_Mandates_and_Florida%20Statutes_2019_01_29.pdf?ver=2019-01-29-130006-790) https://www.sbafla.com/fsb/Portals/FSB/Content/GlobalGovernanceMandates/QuarterlyReports/Global_Governance_Mandates_and_Florida%20Statutes_2019_01_29.pdf?ver=2019-01-29-130006-790.

SECTION XXVII **CONTRACT ADMINISTRATION**

Amendments. The City and the Contractor agree that they will, from time to time, execute, acknowledge and deliver, or cause to be executed, acknowledged and delivered, such supplements hereto and such further instruments as may reasonably be required for carrying out the expressed intention of the Contract. The Contract may be amended in writing from time to time by mutual consent of the parties. All amendments to the Contract must be in writing and fully executed by duly authorized representatives of the City and the Contractor.

Fiscal Year- All reference to Fiscal Year shall mean the City's Fiscal Year. The City's Fiscal Year is from October 1st through September 30th.

Integration of Terms. This Contract represents the entire contract between the parties. The parties shall not rely on any representation that may have been made by either party which is not included in the Contract.

Joint Venture. Nothing in the Contract shall be construed as creating or constituting the relationship of a partnership, joint venture, (or other association of any kind or agent and principal relationship) between the vested parties. Each party shall be deemed to be an independent contractor contracting for the services and acting toward the mutual benefits expected to be derived from the mutually agreed upon contract. Neither Contractor nor any of Contractor's agents, employees, subcontractors or contractors shall become or be deemed to become agents, or employees of the City. Contractor shall therefore be responsible for compliance with all laws, rules and regulations involving its employees and any subcontractors, including but not limited to employment of labor, hours of labor, health and safety, working conditions, workers' compensation insurance, and payment of wages. No party has the authority to enter into any contract or create an obligation or liability on behalf of, in the name of, or binding upon another party to the Contract.

Notice(s). Any and all notices, designations, consents, offers, acceptances or any other communication provided for herein shall be given in writing by registered or certified mail, return receipt requested, by receipted hand delivery, by Fed-EX, UPS, courier or other similar and reliable carrier which shall be addressed to the person who signed the Contract on behalf of the party at the address identified in the contract. Each such notice shall be deemed to have been provided:

- I. Within one (1) day in the case of overnight hand delivery, courier or Services such as Fed-Ex or UPS with guaranteed next day delivery; or,
- II. Within seven (7) days after it is deposited in the U.S. Mail in the case of registered U.S. Mail.

From time to time, the parties may change the name and address of the person designated to receive notice. Such change of the designated person or their designees and/or address shall be in writing to the other party and as provided herein.

Performance by Industry Standards. The Contractor represents and expressly warrants that all aspects of the Services provided or used by it shall, at a minimum, conform to the standards in the Contractor's industry. This requirement shall be in addition to any express warranties, representations, and specifications included in the Contract, which shall take precedence

Permits, Licenses, and Certifications. The Contractor shall be responsible for obtaining all permits, licenses, certifications, etc., required by Federal, State, County, and Municipal laws, regulations, codes, and ordinances for the performance of the work required in these specifications and to conform with the requirements of said legislation. The Contractor shall be required to complete a **W-9 Taxpayer Identification Form**, provided with the City's contract, and return it with the signed contract and insurance documents.

Supersedes Former Contracts or Agreements. Unless otherwise specified in the Contract, this Contract supersedes all prior contracts or agreements between the City and the Contractor for the Services provided in connection with the Contract.

Use of Name or Intellectual Property. Contractor agrees it will not use the name or any intellectual property, including but not limited to, City trademarks or logos in any manner, including commercial advertising or as a business reference, without the expressed prior written consent of the City.

Waiver. Except as specifically provided for in a waiver signed by duly authorized representatives of the City and the Contractor, failure by either party at any time to require performance by the other party or to claim a breach of any provision of the Contract shall not be construed as affecting any subsequent right to require

performance or to claim a breach. Each waiver, if mutually agreed upon, shall be published as a contract amendment.

SECTION XVIII **ADDITIONAL REQUIREMENTS**

In the event of any conflict between the terms and conditions, appearing on any purchase order issued relative to this Contract, and those contained in this Contract and the Specifications herein referenced, the terms of this Contract and Specifications herein referenced shall apply.

City's Public Relations Image. – The Contractor's personnel shall at all times handle complaints and any public contact with due regard to the City's relationship with the public. Any personnel in the employ of the Contractor involved in the execution of work that is deemed to be conducting him/herself in an unacceptable manner shall be removed from the project at the request of the City Manager.

Contractual Relations. - The Contractor(s) are advised that nothing contained in the contract or specifications shall create any contractual relations between the City and Sub-Contractor of the Contractor(s).

Cooperative Purchasing Agreement. - This contract may be expanded to include other governmental agencies provided a cooperative purchasing agreement exists or an inter-local agreement for joint purchasing exists between the City of Port St. Lucie and other public agencies. Contractor(s) may agree to allow other public agencies the same items at the same terms and conditions as this contract, during the period of time that this contract is in effect. Each political entity will be responsible for execution of its own requirements with the Contractor.

Dress Code. – All personnel in the employ of the Contractor(s) shall be appropriately attired. Employees engaged in the course of work shall wear company uniforms neat and clean in appearance, readily identifiable to all City employees and the public. No tee shirts with obscene pictures or writings will be allowed. Swimsuits, tank tops, shorts and sandals are also prohibited. Safety toed shoes shall be worn at all times.

Patent Fees, Royalties, and Licenses. – If the Contractor requires or desires to use any design, trademark, device, material or process covered by letters of patent or copyright, the Contractor and his surety shall indemnify and hold harmless the City from any and all claims for infringement in connection with the work agreed to be performed. The Contractor shall indemnify the City from any cost, expense, royalty or damage which the City may be obligated to pay by reason of any infringement at any time during the prosecution of or after completion of the work.

Permits. - The Contractor shall be responsible for obtaining all permits, licenses, certifications, etc., required by Federal, State, County, and Municipal laws, regulations, codes, and ordinances for the performance of the work required in these specifications and to conform with the requirements of said legislation. The Contractor shall be required to complete a **W-9 Taxpayer Identification Form**, provided with the City's contract, and return it with the signed contract and insurance documents

SECTION XIX
ASSIGNMENT

Contractor shall not delegate, assign or subcontract any part of the work under this Contract or assign any monies due him hereunder without first obtaining the written consent of the City.

SECTION XX
TERMINATION, DELAYS AND LIQUIDATED DAMAGES

Termination for Cause. The occurrence of any one or more of the following events shall constitute cause for the City to declare the Contractor in default of its obligations under the contract:

- I. The Contractor fails to deliver or has delivered nonconforming services or fails to perform, to the City's satisfaction, any material requirement of the Contract or is in violation of a material provision of the contract, including, but without limitation, the express warranties made by the Contractor;
- II. The Contractor fails to make substantial and timely progress toward performance of the contract;
- III. In the event the Contractor is required to be certified or licensed as a condition precedent to providing the Services, the revocation or loss of such license or certification may result in immediate termination of the contract effective as of the date on which the license or certification is no longer in effect;
- IV. The Contractor becomes subject to any bankruptcy or insolvency proceeding under federal or state law to the extent allowed by applicable federal or state law including bankruptcy laws; the Contractor terminates or suspends its business; or the City reasonably believes that the Contractor has become insolvent or unable to pay its obligations as they accrue consistent with applicable federal or state law;
- V. The Contractor has failed to comply with applicable federal, state and local laws, rules, ordinances, regulations and orders when performing within the scope of the contract;
- VI. If the City determines that the actions, or failure to act, of the Contractor, its agents, employees or subcontractors have caused, or reasonably could cause, life, health or safety to be jeopardized;
- VII. The Contractor has engaged in conduct that has or may expose the City to liability, as determined in the City's sole discretion;
- VIII. The Contractor furnished any statement, representation or certification in connection with the contract, which is materially false, deceptive, incorrect or incomplete.

Notice of Default. If there is a default event caused by the Contractor, the City shall provide written notice to the Contractor requesting that the breach or noncompliance be remedied within the period of time specified in the City's written notice to the Contractor. If the breach or noncompliance is not remedied within the period of time specified in the written notice, the City may:

- I. Immediately terminate the contract without additional written notice(s); and/or
- II. Enforce the terms and conditions of the contract and seek any legal or reasonable remedies; and/or

- III. Procure substitute services from another source and charge the difference between the contract and the substitute contract to the defaulting Contractor

Termination for Convenience. The City may, at any time, with or without cause, or for its convenience terminate all or a portion of the Contract upon thirty (30) days written notice to successful Contractor. Any such termination shall be accomplished by delivery in writing of a notice to Contractor. Following termination without cause, the Contractor shall be entitled to compensation upon submission of invoices and proper proof of claim, for services provided under the contract to the City up to the time of termination, pursuant to Florida law.

Termination for Non-Appropriation. The City is a governmental agency which relies upon the appropriation of funds by its governing body to satisfy its obligations. If the City reasonably determines that it does not have funds to meet its obligations under the awarded contract, the City will have the right to terminate the contract, without penalty, on the last day of the fiscal period for which funds were legally available.

Liquidated Damages for Delays. If material is not provided or work is not completed within the time stipulated in this Contract, including any extensions of time for excusable delays as herein provided, (it being impossible to determine the actual damages occasioned by the delay) the Contractor shall provide to the City one thousand (\$1000.00) dollars as fixed, agreed and liquidated damages for each calendar day of delay until the work is completed. The Contractor and his sureties shall be jointly and severally liable to the City for the amount thereof.

SECTION XXI **LAW, VENUE AND WAIVER OF JURY TRIAL**

This Contract is to be construed as though made in and to be performed in the State of Florida and is to be governed by the laws of Florida in all respects without reference to the laws of any other state or nation. The venue of any action taken to enforce this Contract shall be in St. Lucie County, Florida.

The Parties to this Contract hereby freely, voluntarily and expressly, waive their respective rights to trial by jury on any issues so triable after having the opportunity to consult with an attorney.

SECTION XXII **APPROPRIATION APPROVAL**

The Contractor acknowledges that the City of Port St Lucie's performance and obligation to pay under this Contract is contingent upon an annual appropriation by the City Council. The Contractor agrees that, in the event such appropriation is not forthcoming, this Contract may be terminated by the City and that no charges, penalties or other costs shall be assessed.

SECTION XXIII **TRUTH-IN-NEGOTIATIONS**

In accordance with the provisions of Section 287.055, Florida Statutes, the Contractor agrees to execute a truth-in-negotiations certificate and agrees that the original Contract price and any additions may be adjusted to exclude any significant sums by which the Contract price was increased due to inaccurate, incomplete or non-current wage rates and other factual unit costs.

**SECTION XXIV
CONFLICT OF INTEREST**

The City hereby acknowledges that the Contractor may be performing professional services for private developers within the Treasure Coast area. Should a conflict of interest arise between providing services to the City and/or other clients, the Contractor shall terminate its relationship with the other client to resolve the conflict of interest. The City Manager shall determine whether a conflict of interest exists. At the time of each Project Proposal the Contractor shall disclose all of its Treasure Coast clients and related Scope of Work.

**SECTION XXV
PUBLIC RECORDS / TRADE SECRETS / COPYRIGHT**

The Proposer's response to the City's proposal request is a public record pursuant to Florida law, which is subject to disclosure by the City under the State of Florida Public Records Law, [Florida Statutes Chapter 119.07](#) ("Public Records Law"). The City shall permit public access to all documents, papers, letters or other material submitted in connection with this City's proposal request and the Contract to be executed as subject to the provisions of Chapter 119.07 of the Florida Statutes.

Any language contained in the Proposer's response to the Solicitation purporting to require confidentiality of any portion of the Proposer's response to the Solicitation, except to the extent that certain information is in the City's opinion a Trade Secret pursuant to Florida law, shall be void. If a Proposer submits any documents or other information to the City which the Proposer claims is Trade Secret information and exempt from Florida Statutes Chapter 119.07 ("Public Records Laws"), the Proposer shall clearly designate that it is a Trade Secret and that it is asserting that the document or information is exempt. The Proposer must specifically identify the exemption being claimed under Florida Statutes 119.07. The City shall be the final arbiter of whether any information contained in the Proposer's response to the Solicitation constitutes a Trade Secret. The city's determination of whether an exemption applies shall be final, and the Proposer agrees to defend, indemnify, and hold harmless the city and the city's officers, employees, and agent, against any loss or damages incurred by any person or entity as a result of the city's treatment of records as public records. Proposals purporting to be subject to copyright protection in full or in part will be rejected.

EXCEPT FOR CLEARLY MARKED PORTIONS THAT ARE BONA FIDE TRADE SECRETS PURSUANT TO FLORIDA LAW, DO NOT MARK YOUR RESPONSE TO THE SOLICITATION AS PROPRIETARY OR CONFIDENTIAL. DO NOT MARK YOUR RESPONSE TO THE SOLICITATION OR ANY PART THEREOF AS COPYRIGHTED.

**SECTION XXVI
PROHIBITION AGAINST CONTINGENT FEES**

The Contractor warrants that he or she has not employed or retained any company or person, other than a bona fide employee working solely for the Contractor to solicit or secure this Contract and that he or she has not paid or agreed to pay any person, company, corporation, individual, or firm, other than a bona fide employee working solely for the Contractor any fee, commission, percentage, gift, or other consideration contingent upon or resulting from the award or making of this Contract.

SECTION XXVII
ATTORNEY'S FEES

If this matter is placed in the hands of an attorney for collection, or in the event suit or action is instituted by the City to enforce any of the terms or conditions of the Contract, Contractor shall pay to the City, in such suit or action in both trial court and appellate court, the City's costs, and reasonable attorney's fees for the anticipated cost of collection and judgment enforcement.

SECTION XXVIII
CODE OF ETHICS

Contractor warrants and represents that its employees will abide by any applicable provisions of the State of Florida Code of Ethics in [Chapter 112.311 et seq.](#), Florida Statutes, and Code of Ethics Ordinances in [Section 9.14 of the City of Port St. Lucie Code](#).

SECTION XXIX
POLICY OF NON-DISCRIMINATION

Contractor shall not discriminate against any person in its operations, activities or delivery of services under this Contract. Contractor shall affirmatively comply with all applicable provisions of federal, state and local equal employment laws and shall not engage in or commit any discriminatory practice against any person based on race, age, religion, color, gender, sexual orientation, national origin, marital status, physical or mental disability, political affiliation or any other factor which cannot be lawfully used as a basis for service delivery.

SECTION XXX
SEVERABILITY

The Parties to this Contract expressly agree that it is not their intention to violate any public policy, statutory or common law rules, regulations, or decisions of any governmental or regulatory body. If any provision of this Contract is judicially or administratively interpreted or construed as being in violation of any such policy, rule, regulation, or decision, the provision, sections, sentence, word, clause, or combination thereof causing such violation will be inoperative (and in lieu thereof there will be inserted such provision, section, sentence, word, clause, or combination thereof as may be valid and consistent with the intent of the Parties under this Contract) and the remainder of this Contract, as amended, will remain binding upon the Parties, unless the inoperative provision would cause enforcement of the remainder of this Contract to be inequitable under the circumstances.

SECTION XXXI
AUDITS

The Contractor shall establish and maintain a reasonable accounting system that enables the City to readily identify the Contractor's assets, expenses, costs of goods, and use of funds throughout the term of the Contract for a period of at least seven (7) years following the date of final payment or completion of any required audit, whichever is later. Records shall include, but not be limited to, accounting records, written policies and procedures; subcontract files (including proposals of successful and unsuccessful bidders, bid recaps, etc.); all paid vouchers including those for out-of-pocket expenses; other reimbursement supported by invoices; ledgers; cancelled checks; deposit slips; bank statements; journals; original estimates;

estimating work sheets; contract amendments and change order files; back charge logs and supporting documentation; insurance documents; payroll documents; timesheets; memoranda; and correspondence. The Contractor shall permit the City's authorized auditor or any authorized representative of the State, and where federal funds are involved, the Comptroller General of the United States, or any other authorized representative of the United States government, to access and examine, audit, excerpt and to make copies of all books, documents, papers, electronic or optically stored and created records or other records relating or pertaining to this Contract kept by or under the control of the Contractor, including, but not limited to those kept by the Contractor, its employees, agents, assigns, successors, and subcontractors. Such records shall be made available to the City during normal business hours at the Contractor's office or place of business. The Contractor shall not impose a charge for audit or examination of the Contractor's books and records. If an audit discloses incorrect billings or improprieties, the City reserves the right to charge the Contractor for the cost of the audit and appropriate reimbursement. Any adjustments and/or payments that must be made as a result of any such audit or inspection of the Contractor's invoices and/or records shall be made within a reasonable amount of time (not to exceed 90 days) from presentation of the City's findings to the Contractor. Evidence of criminal conduct will be turned over to the proper authorities.

The Contractor shall ensure the City has these rights with Contractor's employees, agents, assigns, successors, and subcontractors, and the obligations of these rights shall be explicitly included in any subcontracts or agreements formed between the Contractor and any subcontractors to the extent that those subcontracts or agreements relate to fulfillment of the Contractor's obligations to the City.

SECTION XXXII **ORDER OF PREFERENCE**

In the case of any inconsistency or conflict among the specific provisions of this Contract (including any amendments accepted by both the City and the Contractor attached hereto), the E-Bid (including any subsequent addenda and written responses to bidders' questions), and the Contractor's Response, any inconsistency or conflict shall be resolved as follows:

- (i) First, by giving preference to the specific provisions of this Contract.
- (ii) Second, by giving preference to the specific provisions of the E-Bid.
- (iii) Third, by giving preference to the specific provisions of the Contractor's Response, except that objections or amendments by a contractor that have not been explicitly accepted by the City in writing shall not be included in this Contract and shall be given no weight or consideration.

SECTION XXXIII **FORCE MAJEURE**

Any deadline provided for in this Contract may be extended, as provided in this paragraph, if the deadline is not met because of one of the following conditions occurring with respect to that particular project or parcel: fire, strike, explosion, power blackout, earthquake, volcanic action, flood, war, civil disturbances, terrorist acts, hurricanes and acts of God. When one of the foregoing conditions interferes with contract performance, then the party affected may be excused from performance on a day-for-day basis to the extent such party's obligations relate to the performance so interfered with; provided, the party so affected shall use reasonable

efforts to remedy or remove such causes of non-performance. The party so affected shall not be entitled to any additional compensation by reason of any day-for-day extension hereunder.

SECTION XXXIV
ENTIRE AGREEMENT

The written terms and provisions of this Contract shall supersede any and all prior verbal or written statements of any official or other representative of the City. Such statements shall not be effective or be construed as entering into, or forming a part of, or altering in any manner whatsoever, this Contract or Contract documents.

(Balance of page left intentionally blank)

IN WITNESS WHEREOF, the parties have executed this contract, the day and year first above written.

CITY OF PORT ST. LUCIE FLORIDA

CONTRACTOR

By: _____ By: _____
Purchasing Agent Authorized Representative

NOTARIZATION AS TO AUTHORIZED REPRESENTATIVE'S EXECUTION

STATE OF FLORIDA)
) ss
COUNTY OF _____)

The foregoing instrument was acknowledged before me by [] physical presence or [] online notarization, this _____ day of _____, 20____, by _____ who is [] personally known to me, or who has [] produced the following identification:

_____.

Signature of Notary Public

Print Name of Notary Public
Notary Public, State of Florida
My Commission expires:

NOTARY SEAL/STAMP



"A City for All Ages"

NOTICE TO ALL PROPOSERS:

To ensure fair consideration is given for all Proposers, it must be clearly understood that upon release of the proposal and during the proposal process, firms and their employees of related companies as well as paid or unpaid personnel acting on their behalf shall not contact or participate in any type of contact with City employees, department heads or elected officials, up to and including the Mayor and City Council. The "Cone of Silence" is in effect for this solicitation from the date the solicitation is advertised on DemandStar, until the time an award decision has been approved by City Council and fully executed by all parties. Information about the Cone of Silence can be found under the City of Port St. Lucie Ordinance 20-15, Section 35.13. Contact with anyone other than the Issuing Officer may result in the vendor being disqualified. All contact must be coordinated through **Michelle Fentress**, Issuing Officer, for the procurement of these services.

All questions regarding this Solicitation are to be submitted in writing to **Michelle Fentress**, Procurement Agent I with the Procurement Management Department via e-mail mfentress@cityofpsl.com, or by phone 772-871-5222. Please reference the Solicitation number on all correspondence to the City.

All questions, comments and requests for clarification must reference the Solicitation number on all correspondence to the City. Any oral communications shall be considered unofficial and non-binding.

Only written responses to written communication shall be considered official and binding upon the City. The City reserves the right, at its sole discretion, to determine appropriate and adequate responses to the written comments, questions, and requests for clarification.

*NOTE: All addendums and/or any other correspondence before bid close date (general information, question and responses) to this solicitation will be made available exclusively through the [DemandStar's Website](#) for retrieval. All notice of intent to award documentation will be published on the [City Clerk's Website](#). Proposers are solely responsible for frequently checking these websites for updates to this solicitation.

I understand and shall fully comply with all requirements of City of Port. St. Lucie Ordinance 20-15, Section 35.13.

Typed Name: _____

Signed: _____

Company and Job Title: _____

Date: _____

CONTRACTOR'S GENERAL INFORMATION WORK SHEET
eBID #20220028

It is understood and agreed that the following information is to be used by the City to determine the qualifications of prospective Contractor to perform the work required. The Contractor waives any claim against the City that might arise with respect to any decision concerning the qualifications of the Contractor.

The undersigned attests to the truth and accuracy of all statements made on this questionnaire. Also, the undersigned hereby authorizes any public official, Engineer, Surety, bank, material or equipment manufacturer, or distributor, or any person, firm or corporation to furnish the City any pertinent information requested by the City deemed necessary to verify the information on this questionnaire.

Dated at _____, this _____ day of _____, 2022.
(Location)

Name of Organization/Contractor: _____

By: _____
Name and Title

1. Corporation, Partnership, Joint Venture, Individual or other? _____

2. Firm's name and main office address, telephone and fax numbers

Name: _____

Address: _____

Telephone Number: _____

Fax Number: _____

3. Contact person: _____ Email: _____

4. Firm's previous names (if any). _____

5. How many years has your organization been in business? _____

6. Total number of staff at this location: _____ Total number of staff on the Treasure Coast: _____

7. Is the Firm a minority business: YES / NO

If no, is your company planning to implement such a program? _____

8. Is the firm claiming Local Preference under City Ordinance 35.12? YES / NO

9. List the license(s) that qualifies your firm to construct this project: _____

10. **ADDENDUM ACKNOWLEDGMENT** - Bidder acknowledges that the following addenda have been received and are included in its proposal/bid:

Addendum Number	Date Issued	Addendum Number	Date Issued

11. **BID RESPONSE:**

11.1 Bidder will / will not accept the Purchasing Card (Visa).
(please circle one)

11.2 Percentage of discount when payment is made with Visa: _____ %
*Please Note: The City has implemented a **Purchasing Card Program**. The Bidder can take advantage of this project and in consideration receive payment within several days instead of the City’s payment policy. Any percentage off the bid price for the acceptance of Visa will be consideration in the bid award. If no such percentage is given, the City shall assume zero (0) percent discount applies.*

11.3 Bid Reply Total from Cost Worksheet – Schedule “A”: \$ _____
(This figure must match the Cost Worksheet and the figure that is to be used on the DemandStar web page. Discrepancies between the Cost Worksheet spreadsheet uploaded on DemandStar, the dollar amount listed on the web page at the time of submittal and the Cost Work Sheet #20220028 uploaded on DemandStar will be resolved in favor of the Cost Worksheet – Schedule “A” that is uploaded at time of submittal.)

Bidders are cautioned that the anticipated quantities used for this computation will be estimates. The City makes no guarantee as to the actual quantity that will be utilized during the Contract period. A unit price for each item shall be offered shall be shown, and such price shall include packing and shipping unless otherwise specified. A total shall be entered in the “Total” column for each separate item. In case of discrepancy between the unit price and the extended price, the unit price will supersede. The total amount shall be entered on line 11.3 above and entered on the DemandStar web page. The City reserves the right to split the award, if in the City’s opinion such a split is in the best interest of the City.

Interpretation of the Approximate Quantities - The Bidder’s attention is called to the fact that any estimate of quantities of work to be done and materials to be furnished under the specifications as shown on the proposed form (or elsewhere) is approximate only and not guaranteed by the City. The City does not assume any responsibility that the final quantities shall remain in strict accordance with the estimated quantities, nor shall the Bidder plead misunderstanding or deception because of such estimate of quantities or of the character, location of the work, or other condition pertaining thereto.

12. List five (5) projects similar to this project completed by your firm in the last 5 years along with a brief description of project, location of project, client name, client phone number, email, value of contract, your

firm's percentage of the total contract value, as well as the number of change orders and the total change order value. **DO NOT USE the City of Port St Lucie as a reference.**

Project Number 1

Project Name:

Description:

Location:

Client Name, Phone Number & Email:

Value of Total Contract:

Date of Completion:

Firm's Percentage of Total Contract:

Number of Change Orders:

Value of Change Orders:

Was Project Completed on Schedule:

Was Project Completed within Budget?

Project Number 2

Project Name:

Description:

Location:

Client Name, Phone Number & Email:

Value of Total Contract:

Date of Completion:

Firm's Percentage of Total Contract:

Number of Change Orders:

Value of Change Orders:

Was Project Completed on Schedule:

Was Project Completed within Budget?

Project Number 3

Project Name:

Description:

Location:

Client Name, Phone Number & Email:

Value of Total Contract:

Date of Completion:

Firm's Percentage of Total Contract:

Number of Change Orders:

Value of Change Orders:

Was Project Completed on Schedule:

Was Project Completed within Budget?

Project Number 4

Project Name:

Description:

Location:

Client Name, Phone Number & Email:

Value of Total Contract:

Date of Completion:

Firm's Percentage of Total Contract:

Number of Change Orders:

Value of Change Orders:

Was Project Completed on Schedule:

Was Project Completed within Budget?

Project Number 5

Project Name:

Description:

Location:

Client Name, Phone Number & Email:

Value of Total Contract:

Date of Completion:

Firm's Percentage of Total Contract:

Number of Change Orders:

Value of Change Orders:

Was Project Completed on Schedule:

Was Project Completed within Budget?

13. Status of current contracts. Please provide the name & number of current contracts as well as a sample list of the projects currently underway.

14. How will the Contractor be able to meet the project timeline and budget given the current workload, work force and equipment?

15. List the number of personnel that will be assigned to the project and include job titles and their licenses or certifications.

16. Has the Contractor or any principals of the applicant organization failed to qualify as a responsible Contractor; refused to enter into a contract after an award has been made; failed to complete a contract during the past five (5) years or been declared to be in default in any contract or been assessed liquidated damages in the last five (5) years? List the name of project, location, client, engineer, date and reason. Use additional pages if needed.

Total Number of Projects where Failure to Complete Work Occurred: _____

Project Number 1

Project Name: _____

Project Location: _____

Client Name and Phone Number: _____

Engineer Name and Phone Number: _____

Date: _____

Reason: _____

Insert additional projects if needed.

17. Has the Contractor or any of its principals ever been declared bankrupt or reorganized under Chapter 11 or put into receivership?

Yes () No ()

If yes, please explain:

18. List any lawsuits pending or completed within the past five (5) years involving the corporation, partnership or individuals with more than ten percent (10 %) interest:

(N/A is not an acceptable answer - insert lines if needed)

19. List any judgments from lawsuits in the last five (5) years:

(N/A is not an acceptable answer - insert lines if needed)

20. List any criminal violations and/or convictions of the Proposer and/or any of its principals:

(N/A is not an acceptable answer - insert lines if needed)

21. List subcontractors and major material suppliers for the project. Include telephone numbers. Insert additional sheets if necessary. **All subcontractors listed must complete a "Certification Regarding Lobbying" form and is to be included in the bid package. Attach all licenses and certifications that qualify them to perform the work.**

23. Provide a Project Management Plan.

24. Provide an Equipment List.

25. Provide a Project Schedule.

Signature Title



"A City for All Ages"

eBID #20220028
CONTRACTOR'S CODE OF ETHICS

The City of Port St Lucie ("City), through its Procurement Management Department ("Procurement Management Department") is committed to a procurement process that fosters fair and open competition, is conducted under the highest ethical standards and enjoys the complete confidence of the public. To achieve these purposes, Procurement Management Department requires each vendor who seeks to do business with the City to subscribe to this Contractor's Code of Ethics.

- ◆ A Contractor's bid or proposal will be competitive, consistent and appropriate to the bid documents.
- ◆ A Contractor will not discuss or consult with other Vendors intending to bid on the same contract or similar City contract for the purpose of limiting competition. A Vendor will not make any attempt to induce any individual or entity to submit or not submit a bid or proposal.
- ◆ Contractor will not disclose the terms of its bids or proposal, directly or indirectly, to any other competing Vendor prior to the bid or proposal closing date.
- ◆ Contractor will completely perform any contract awarded to it at the contracted price pursuant to the terms set forth in the contract.
- ◆ Contractor will submit timely, accurate and appropriate invoices for goods and/or services actually performed under the contract.
- ◆ Contractor will not offer or give any gift, item or service of value, directly or indirectly, to a City employee, City official, employee family member or other vendor contracted by the City.
- ◆ Contractor will not cause, influence or attempt to cause or influence, any City employee or City Official, which might tend to impair his/her objectivity or independence of judgment; or to use, or attempt to use, his/her official position to secure any unwarranted privileges or advantages for that Vendor or for any other person.
- ◆ Contractor will disclose to the City any direct or indirect personal interests a City employee or City official holds as it relates to a Vendor contracted by the City.
- ◆ Contractor must comply with all applicable laws, codes or regulations of the countries, states and localities in which they operate. This includes, but is not limited to, laws and regulations relating to environmental, occupational health and safety, and labor practices. In addition, Contractor

must require their suppliers (including temporary labor agencies) to do the same. Contractor must conform their practices to any published standards for their industry. Compliance with laws, regulations and practices include, but are not limited to the following:

- Obtaining and maintaining all required environmental permits. Further, Contractor will endeavor to minimize natural resource consumption through conservation, recycling and substitution methods.
- Providing workers with a safe working environment, which includes identifying and evaluating workplace risks and establishing processes for which employee can report health and safety incidents, as well as providing adequate safety training.
- Providing workers with an environment free of discrimination, harassment and abuse, which includes establishing a written antidiscrimination and anti-bullying/harassment policy, as well as clearly noticed policies pertaining to forced labor, child labor, wage and hours, and freedom of association.

Name of Organization/Proposer _____

Signature _____

Printed Name and Title _____

Date _____

DISCLAIMER: This Code of Ethics is intended as a reference and procedural guide to contractors. The information it contains should not be interpreted to supersede any law or regulation, nor does it supersede the applicable contractor contract. In the case of any discrepancies between it and the law, regulation(s) and/or contractor contract, the law, regulatory provision(s) and/or vendor contract shall prevail.



"A City for All Ages"

**DRUG-FREE WORKPLACE FORM
e-BID #20220028**

Remove & Replace 8,000 Gallon Diesel Fuel Tank @ Southport Booster Station

The undersigned vendor in accordance with Florida Statute 287.087 hereby certifies that

_____ does:

(Name of Business)

1. Publish a statement notifying employees that the unlawful manufacture, distribution, dispensing, possession, or use of a controlled substance is prohibited in the workplace and specifying the actions that will be taken against employees for violations of such prohibition.
2. Inform employees about the dangers of drug abuse in the workplace, the business's policy of maintaining a drug-free workplace, any available drug counseling, rehabilitation, and employee assistance programs, and the penalties that may be imposed upon employees for drug abuse violations.
3. Give each employee engaged in providing the commodities or contractual services that are under proposal a copy of the statement specified in subsection (1).
4. In the statement specified in subsection (1), notify the employees that, as a condition of working on the commodities or contractual services that are under proposal, the employee will abide by the terms of the statement and will notify the employer of any conviction of, or plea of guilty or nolo contendere to, any violation of Chapter 893 Florida Statutes or of any controlled substance law of the United States or any state, for a violation occurring in the workplace no later than five (5) days after such conviction.
5. Impose a sanction on or require the satisfactory participation in a drug abuse assistance or rehabilitation program if such is available in the employee's community, by any employee who is so convicted.
6. Make a good faith effort to continue to maintain a drug-free workplace through implementation of this section.

As the person authorized to sign the statement, I certify that this firm complies fully with the above requirements.

Contractor's Signature

Date

CITY OF PORT ST. LUCIE, FLORIDA

eBID No. #20220028

PROJECT TITLE: Remove & Replace 8,000 Gallon Diesel Fuel Tank @ Southport Booster Station

CERTIFICATION REGARDING LOBBYING

The undersigned Contractor certifies, to the best of his or her knowledge and belief, that:

- (1) No Federal appropriated funds have been paid or will be paid, by or on behalf of the undersigned, to any person for influencing or attempting to influence an officer or employee of an agency, a Member of Congress, an officer or employee of Congress, or an employee of a Member of Congress in connection with the awarding of any Federal contract, the making of any Federal grant, the making of any Federal loan, the entering into of any cooperative agreement, and the extension, continuation, renewal, amendment, or modification of any Federal contract, grant, loan, or cooperative agreement.
(2) If any funds other than Federal appropriated funds have been paid or will be paid to any person for making lobbying contacts to an officer or employee of any agency, a Member of Congress, an officer or employee of Congress, or an employee of a Member of Congress in connection with this Federal contract, grant, loan, or cooperative agreement, the undersigned shall complete and submit Standard Form - LLL, "Disclosure Form to Report Lobbying," in accordance with its instructions [as amended by "Government wide Guidance for New Restrictions on Lobbying", 61 Fed. Reg. 1413 (1/19/96). Note: Language in paragraph (2) herein has been modified in accordance with Section 10 of the Lobbying Disclosure Act of 1995 (P.L. 104-65, to be codified at 2 U.S.C. 1601, et seq.)]
(3) The undersigned shall require that the language of this certification be included in the awards documents for all subawards at all tiers (including subcontracts, subgrants, and contracts under grants, loans, and cooperative agreements) and that all subrecipients shall certify and disclose accordingly.

This certification is a material representation of fact upon which reliance was placed when this transaction was made or entered into. Submission of this certification is a prerequisite for making or entering into this transaction imposed by 31, U.S.C. 1352 (as amended by the Lobbying Disclosure Act of 1995). Any person who fails to file the required certification shall be subject to a civil penalty of not less than \$10,000 and not more than \$100,000 for each such failure.

[Note: Pursuant to 31 U.S.C. 1352 (1)-(2)(A), any person who makes a prohibited expenditure of fails to file or amend a required certification or disclosure form shall be subject to a civil penalty of not less than \$10,000 and not more than \$100,000 for each such expenditure or failure]

The Contractor, certifies or affirms the truthfulness and accuracy of each statement of its certification and disclosure, if any. In addition, the Contractor understands and agrees that the provisions of 31 U.S.C. A 3801, et seq., apply to this certification and disclosure, if any.

Company Name: _____

Authorized By: _____
(Sign) (Print Name)

Title: _____ Date: _____

ALL SUBCONTRACTORS ARE REQUIRED TO FILL OUT THIS FORM AND SUBMIT WITH BID PACKAGE This is a mandatory document. No exceptions will be made.

CITY OF PORT ST. LUCIE, FLORIDA
SEALED BID NO. 20220028
PROJECT TITLE: Remove & Replace 8,000 Gallon Diesel Fuel Tank
@ Southport Booster Station

TRENCH SAFETY ACT COMPLIANCE STATEMENT

Project Name: **Remove & Replace 8,000 Gallon Diesel Fuel Tank @ Southport Booster Station**

Project Location: 1615 SE Sunshine Avenue, Port St. Lucie, Florida

Instructions:

Chapter 90-96 of the Laws of Florida requires all Contractors' engaged by The City of Port St. Lucie, Florida to comply with Occupational Safety and Health Administration Standard 29 C.F.R. s. 1926.650 Subpart P. All prospective Contractors are required to sign the compliance statement and provide compliance cost information where indicated below. The costs for complying with the Trench Safety Act must be incorporated into this project's base bid.

Certify this form in the presence of a notary public or other officer authorized to administer oaths.

Certification

1. I understand that Chapter 90-96 of the Laws of Florida (The Trench Safety Act) requires me to comply with OSHA Standard 29 C.F.R. s. 1926.650 Subpart P. I will comply with The Trench Safety Act and I will design and provide trench safety systems at all trench excavations in excess of five feet in depth for this project.

2. The estimated cost imposed by compliance with The Trench Safety Act will be:

_____ Dollars
(Written) (Figures)

3. The amount listed above has been included within the Base Bid.

Certified: _____
(Company-Contractor)

By: _____
(President's Signature)
(President's Typed or Printed Name)

Sworn to and subscribed before me in _____ County, Florida on the day of _____, 20__.

NOTARY PUBLIC



"A City for All Ages"

NON-COLLUSION AFFIDAVIT
Solicitation#20220028
Remove & Replace 8,000 Gallon Diesel Fuel
Tank @ Southport Booster Station

State of _____ }

County of _____ }

_____, being first duly sworn, disposes and says that:
(Name/s)

1. They are _____ of _____ the Proposer that
(Title) (Name of Company)

has submitted the attached PROPOSAL;

2. He is fully informed respecting the preparation and contents of the attached proposal and of all pertinent circumstances respecting such PROPOSAL;

3. Such Proposal is genuine and is not a collusive or sham Proposal;

4. Neither the said Proposer nor any of its officers, partners, owners, agents, representatives, employees or parties in interest, including this affiant, has in any way colluded, conspired, connived or agreed, directly or indirectly with any other Proposer, firm or person to submit a collusive or sham Proposal in connection with the contract for which the attached proposal has been submitted or to refrain from proposing in connection with such Contract or has in any manner, directly or indirectly, sought by agreement or collusion or communication or conference with any other Proposer, firm or person to fix the price or prices in the attached Proposal or of any other Proposer, or to secure through any collusion, conspiracy, connivance or unlawful agreement any advantage against the City of Port St. Lucie or any person interested in the proposed Contract; and

5. The price or prices quoted in the attached Proposal are fair and proper and are not tainted by any collusion, conspiracy, connivance or unlawful agreement on the part of the Proposer or any of its agents, representatives, owners, employees, or parties in interest, including this affiant.

(Signed) _____

(Title) _____



"A City for All Ages"

STATE OF FLORIDA }
COUNTY OF ST. LUCIE} SS:

The foregoing instrument was acknowledged before me this *(Date)* _____

by: _____ who is personally known to me or who has produced
_____ as identification and who did (did not) take an oath.

Commission No. _____

Notary Print: _____

Notary Signature: _____