

RIVERLAND BOULEVARD AT RIVERLAND PASEO OVERPASS

A PARCEL OF LAND LYING IN SECTIONS 20 & 21, TOWNSHIP 37 SOUTH, RANGE 39 EAST, CITY OF PORT ST. LUCIE, ST. LUCIE COUNTY, FLORIDA

SHEET 1 OF 4

LEGAL DESCRIPTION

BEING A PORTION OF N/S B RIGHT-OF-WAY, 150 FEET IN WIDTH, AS RECORDED IN OFFICIAL RECORDS BOOK 3902, PAGE 490, LYING WITHIN SECTIONS 20 AND 21, TOWNSHIP 37 SOUTH, RANGE 39 EAST, PUBLIC RECORDS, ST. LUCIE COUNTY, FLORIDA AND BEING MORE PARTICULARLY DESCRIBED AS FOLLOWS:

BEGIN AT THE SOUTHEAST CORNER OF RIVERLAND BOULEVARD ACCORDING TO THE PLAT OF RIVERLAND BOULEVARD AT RIVERLAND PARCEL C, AS RECORDED IN PLAT BOOK 85, PAGE 19, SAID PUBLIC RECORDS; THENCE SOUTH 00°28'42" EAST, ALONG THE EAST LINE OF SAID N/S B RIGHT-OF-WAY, A DISTANCE OF 1589.64 FEET; THENCE SOUTH 89°31'18" WEST, A DISTANCE OF 150.00 FEET; THENCE NORTH 00°28'42" WEST, ALONG THE WEST LINE OF SAID N/S B RIGHT-OF-WAY, A DISTANCE OF 1589.64 FEET; THENCE NORTH 89°31'18" EAST, ALONG THE SOUTH OF SAID RIVERLAND BOULEVARD, A DISTANCE OF 150.00 FEET TO THE POINT OF BEGINNING

CONTAINING 5.474 ACRES, MORE OR LESS.

CERTIFICATION OF OWNERSHIP & DEDICATION

STATE OF FLORIDA
COUNTY OF ST. LUCIE

THE CITY OF PORT ST. LUCIE, A MUNICIPAL CORPORATION OF THE STATE OF FLORIDA, OWNER OF THE LAND DESCRIBED AND PLATTED HEREIN AS RIVERLAND BOULEVARD AT RIVERLAND PASEO OVERPASS, BEING IN ST. LUCIE COUNTY, FLORIDA, HAVE CAUSED SAID LANDS TO BE SURVEYED AND PLATTED AS SHOWN HEREON AND HEREBY DEDICATES AS FOLLOWS:

RIVERLAND BOULEVARD, SHOWN ON THIS PLAT IS DEDICATED TO THE CITY OF PORT ST. LUCIE, A MUNICIPAL CORPORATION OF THE STATE OF FLORIDA, FOR THE BENEFIT OF THE PUBLIC FOR ROAD RIGHT-OF-WAY PURPOSES AND IS THE MAINTENANCE RESPONSIBILITY OF THE CITY OF PORT ST. LUCIE.

IN WITNESS WHEREOF, THE ABOVE NAMED CITY OF PORT ST. LUCIE HAS CAUSED THESE PRESENTS TO BE SIGNED BY ITS MAYOR, THIS ____ DAY OF _____, 2021.

BY: _____ DATE: _____
GREGORY J. ORAVEC, MAYOR

WITNESS: _____ WITNESS: _____

PRINT NAME: _____ PRINT NAME: _____

ACKNOWLEDGMENT

STATE OF FLORIDA
COUNTY OF ST. LUCIE

THE FOREGOING CERTIFICATE OF OWNERSHIP WAS ACKNOWLEDGED BEFORE ME, BY MEANS OF () PHYSICAL PRESENCE OR () ONLINE NOTARIZATION, THIS ____ DAY OF _____, 2021 BY GREGORY J. ORAVEC, AND HE ACKNOWLEDGED TO AND BEFORE ME THAT HE EXECUTED SAID INSTRUMENT AS MAYOR OF SAID CITY OF PORT ST. LUCIE. HE IS () PERSONALLY KNOWN TO ME, OR () HAS PRODUCED _____ AS IDENTIFICATION AND DID TAKE AN OATH.

NOTARY PUBLIC: _____

PRINT NAME: _____

MY COMMISSION EXPIRES: _____



COMMISSION NUMBER: _____

ACCEPTANCE OF DEDICATION

STATE OF FLORIDA
COUNTY OF ST. LUCIE

CITY OF PORT ST. LUCIE, HEREBY:

1) ACCEPTS THE DEDICATIONS AND/OR THEIR OBLIGATIONS AS STATED HEREON OF RIVERLAND BOULEVARD AS SET FORTH WITHIN THIS PLAT AND SPECIFICALLY DEDICATED TO CITY OF PORT ST. LUCIE.

2) CONSENTS TO THE PLATTING OF THE LANDS HEREIN.

DATED THIS ____ DAY OF _____, 2021.

GREGORY J. ORAVEC, MAYOR

WITNESS: _____ WITNESS: _____

PRINT NAME: _____ PRINT NAME: _____

ACKNOWLEDGMENT

STATE OF FLORIDA
COUNTY OF ST. LUCIE

THE FOREGOING ACCEPTANCE OF DEDICATION WAS ACKNOWLEDGED BEFORE ME, BY MEANS OF () PHYSICAL PRESENCE OR () ONLINE NOTARIZATION, THIS ____ DAY OF _____, 2021 BY GREGORY J. ORAVEC, AND HE ACKNOWLEDGED TO AND BEFORE ME THAT HE EXECUTED SAID INSTRUMENT AS MAYOR OF SAID CITY OF PORT ST. LUCIE. HE IS () PERSONALLY KNOWN TO ME, OR () HAS PRODUCED _____ AS IDENTIFICATION AND DID TAKE AN OATH.

NOTARY PUBLIC: _____

PRINT NAME: _____

MY COMMISSION EXPIRES: _____



COMMISSION NUMBER: _____

TITLE CERTIFICATION

THE UNDERSIGNED, FIDELITY NATIONAL TITLE INSURANCE COMPANY, A FLORIDA CORPORATION, A TITLE INSURANCE COMPANY AS DULY LICENSED IN THE STATE OF FLORIDA, DOES HEREBY CERTIFY THAT, AS OF THE ____ DAY OF _____, 2021:

- A. THE RECORD TITLE TO THE LAND AS DESCRIBED AND SHOWN HEREON IS IN THE NAME OF THE CITY OF PORT ST. LUCIE, THE ENTITY EXECUTING THE DEDICATION.
- B. THERE ARE NO MORTGAGES OF RECORD, ENCUMBERING THE LAND DESCRIBED HEREON.
- C. PURSUANT TO FLORIDA STATUTE 197.192, ALL TAXES HAVE BEEN PAID THROUGH THE YEAR 2020.
- D. ALL ASSESSMENTS AND OTHER ITEMS HELD AGAINST SAID LAND HAVE BEEN SATISFIED.
- E. THERE ARE ENCUMBRANCES OF RECORD BUT THOSE ENCUMBRANCES DO NOT PROHIBIT THE CREATION OF THE SUBDIVISION DEPICTED BY THIS PLAT.

DATED THIS ____ DAY OF _____, 2021.

FIDELITY NATIONAL TITLE INSURANCE COMPANY
A FLORIDA CORPORATION

BY: _____
GEORGE TELLEZ, VICE PRESIDENT

APPROVAL OF CITY COUNCIL

STATE OF FLORIDA
COUNTY OF ST. LUCIE

IT IS HEREBY CERTIFIED THAT THIS PLAT OF RIVERLAND BOULEVARD AT RIVERLAND PASEO OVERPASS, HAS BEEN OFFICIALLY APPROVED FOR RECORD BY THE CITY COUNCIL OF THE CITY OF PORT ST. LUCIE AND ALL DEDICATIONS TO THE CITY OF PORT ST. LUCIE HEREIN ARE ACCEPTED THIS ____ DAY OF _____, 2021.

CITY OF PORT ST. LUCIE ATTEST:

GREGORY J. ORAVEC, MAYOR SALLY WALSH, CITY CLERK

CLERK'S RECORDING CERTIFICATE

STATE OF FLORIDA
COUNTY OF ST. LUCIE

I MICHELLE R. MILLER, CLERK OF THE CIRCUIT COURT OF ST. LUCIE, FLORIDA, DO HEREBY CERTIFY THAT THIS PLAT HAS BEEN EXAMINED, AND THAT IT COMPLIES IN FORM WITH ALL THE REQUIREMENTS OF THE LAWS OF FLORIDA PERTAINING TO MAPS AND PLATS, AND THAT THIS PLAT HAS BEEN FILED FOR RECORD IN PLAT BOOK _____ PAGES _____ OF THE PUBLIC RECORDS OF ST. LUCIE COUNTY, FLORIDA, THIS ____ DAY OF _____, 2021.

MICHELLE R. MILLER, CLERK OF THE CIRCUIT COURT
ST. LUCIE COUNTY, FLORIDA

CERTIFICATE OF SURVEYOR AND MAPPER

THIS IS TO CERTIFY THAT THE PLAT AS SHOWN HEREON IS A TRUE AND CORRECT REPRESENTATION OF A SURVEY MADE UNDER MY RESPONSIBLE DIRECTION AND SUPERVISION AND THAT SAID SURVEY IS ACCURATE TO THE BEST OF MY KNOWLEDGE AND BELIEF; THAT PERMANENT REFERENCE MONUMENTS (P.R.M.'S) HAVE BEEN SET AND THAT PERMANENT CONTROL POINTS (P.C.P.'S) AND LOT CORNERS WILL BE SET UNDER THE GUARANTEES POSTED WITH THE CITY COUNCIL OF PORT ST. LUCIE FOR THE REQUIRED IMPROVEMENTS, AND FURTHER, THAT THE SURVEY DATA COMPLIES WITH ALL OF THE REQUIREMENTS OF CHAPTER 177, FLORIDA STATUTES, AS AMENDED, AND IN ACCORDANCE WITH THE SURVEYING STANDARDS CONTAINED WITHIN CHAPTER 5J-17, FLORIDA ADMINISTRATIVE CODE, SET FORTH BY THE FLORIDA BOARD OF SURVEYORS AND MAPPERS PURSUANT TO SECTION 472.027, FLORIDA STATUTES, AND ORDINANCES OF THE CITY OF PORT ST. LUCIE, FLORIDA, THIS ____ DAY OF _____, 2021.

PERRY C. WHITE
PROFESSIONAL SURVEYOR & MAPPER
FLORIDA REGISTRATION NO. 4215
SAND & HILLS SURVEYING, INC.
8461 LAKE WORTH ROAD, SUITE 410
LAKE WORTH, FLORIDA 33467

SURVEYOR'S NOTES:

- 1) BEARINGS SHOWN HEREON ARE BASED ON THE STATE PLANE GRID, FLORIDA EAST ZONE, ALONG THE WEST LINE OF RIVERLAND PARCEL A - PLAT FIFTEEN, AS RECORDED IN PLAT BOOK 89, PAGE 14, PUBLIC RECORDS OF ST. LUCIE COUNTY, FLORIDA, HAVING A BEARING OF SOUTH 00°28'42" EAST, WITH ALL BEARINGS SHOWN HEREON BEING RELATIVE THERETO.
- 2) NOTICE: THIS PLAT, AS RECORDED IN ITS GRAPHIC FORM IS THE OFFICIAL DEPICTION OF THE SUBDIVIDED LANDS DESCRIBED HEREIN AND WILL IN NO CIRCUMSTANCES BE SUPPLANTED IN THE AUTHORITY BY ANY OTHER GRAPHIC OR DIGITAL FORM OF THE PLAT.
- 3) THERE MAY BE ADDITIONAL RESTRICTIONS THAT ARE NOT RECORDED ON THIS PLAT THAT MAY BE FOUND IN THE PUBLIC RECORDS OF THIS COUNTY.
- 4) ALL DISTANCES SHOWN HEREON ARE IN U.S. SURVEY FEET AND DECIMALS THEREOF.
- 5) THIS PLAT HAS BEEN REVIEWED FOR CONFORMITY TO CHAPTER 177, PART 1, FLORIDA STATUTES BY A PROFESSIONAL SURVEYOR AND MAPPER EMPLOYED BY OR UNDER CONTRACT WITH THE CITY OF PORT ST. LUCIE.

THIS INSTRUMENT PREPARED BY
PERRY C. WHITE, P.S.M. 4213,
STATE OF FLORIDA
SAND & HILLS SURVEYING, INC.
8461 LAKE WORTH ROAD, SUITE 410
LAKE WORTH, FLORIDA 33467 LB-7741

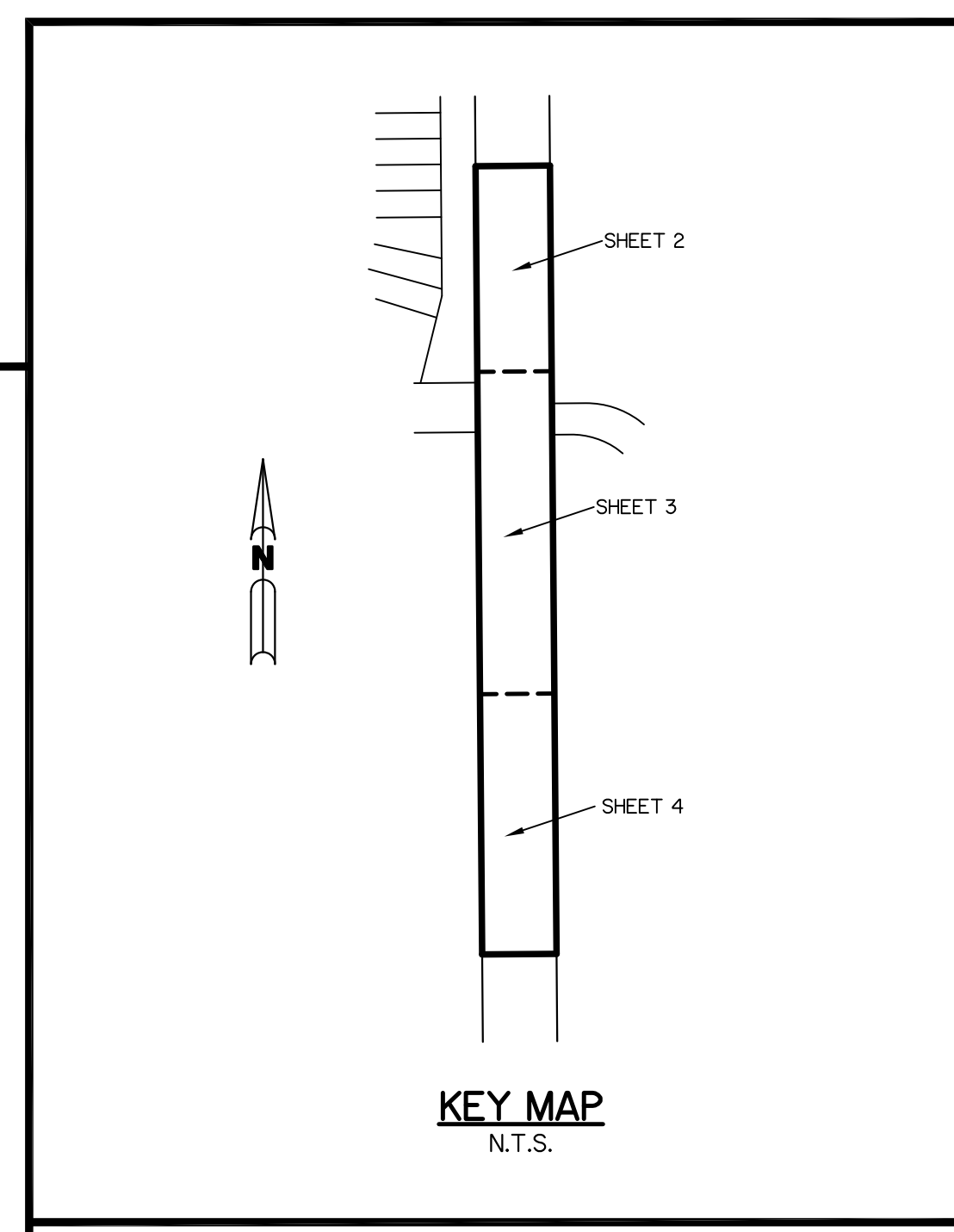
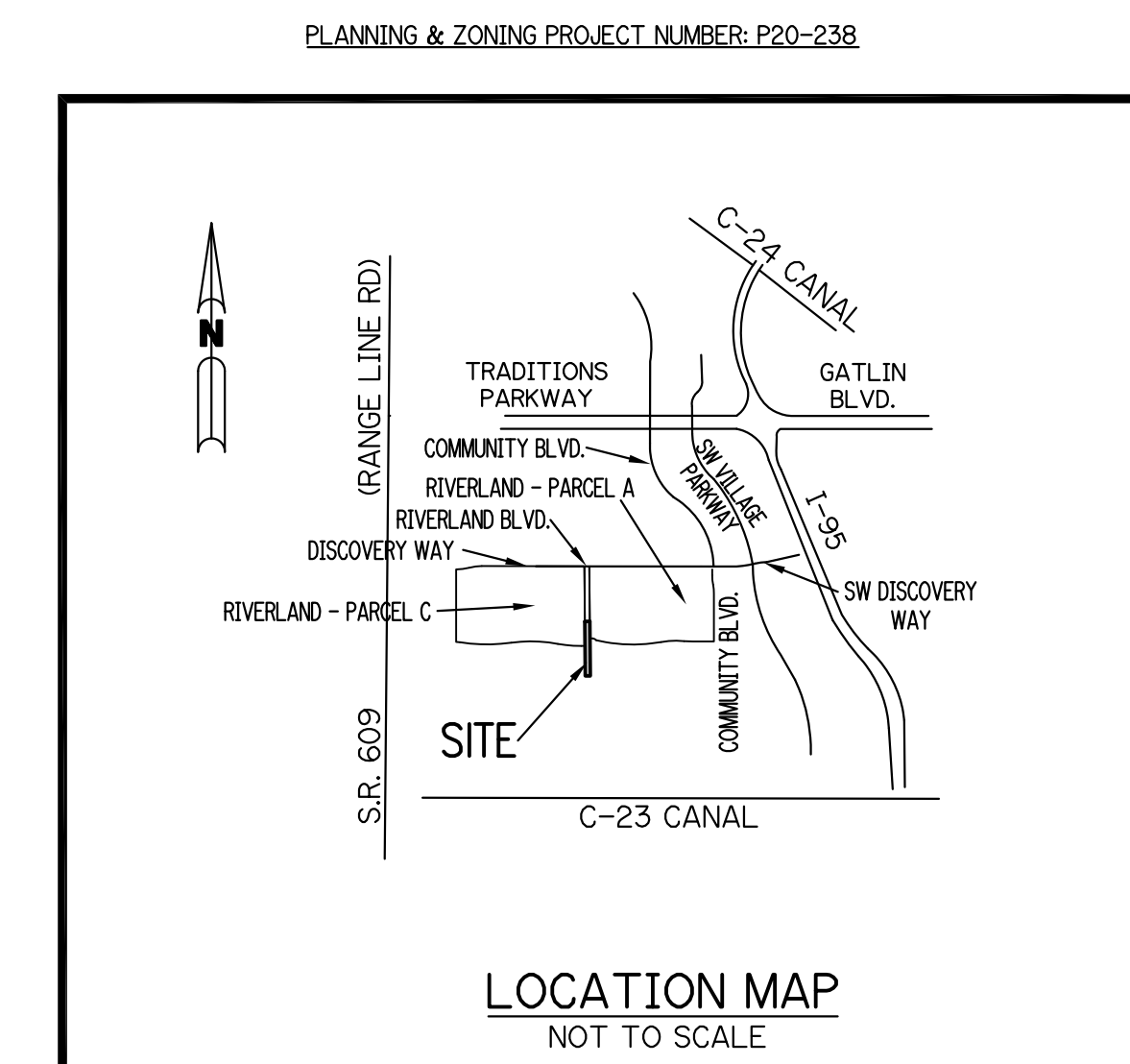
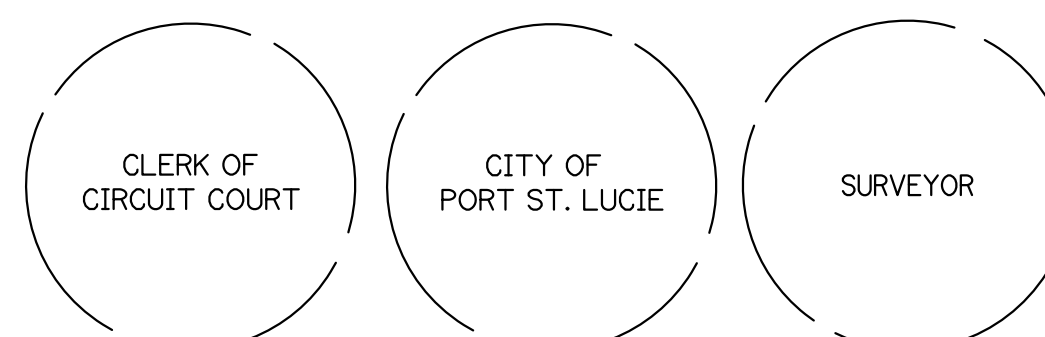

RIVERLAND BOULEVARD AT RIVERLAND PASEO OVERPASS

A PARCEL OF LAND LYING IN SECTIONS 20 & 21, TOWNSHIP 37 SOUTH,
RANGE 39 EAST, CITY OF PORT ST. LUCIE, ST. LUCIE COUNTY, FLORIDA

SHEET 2 OF 4

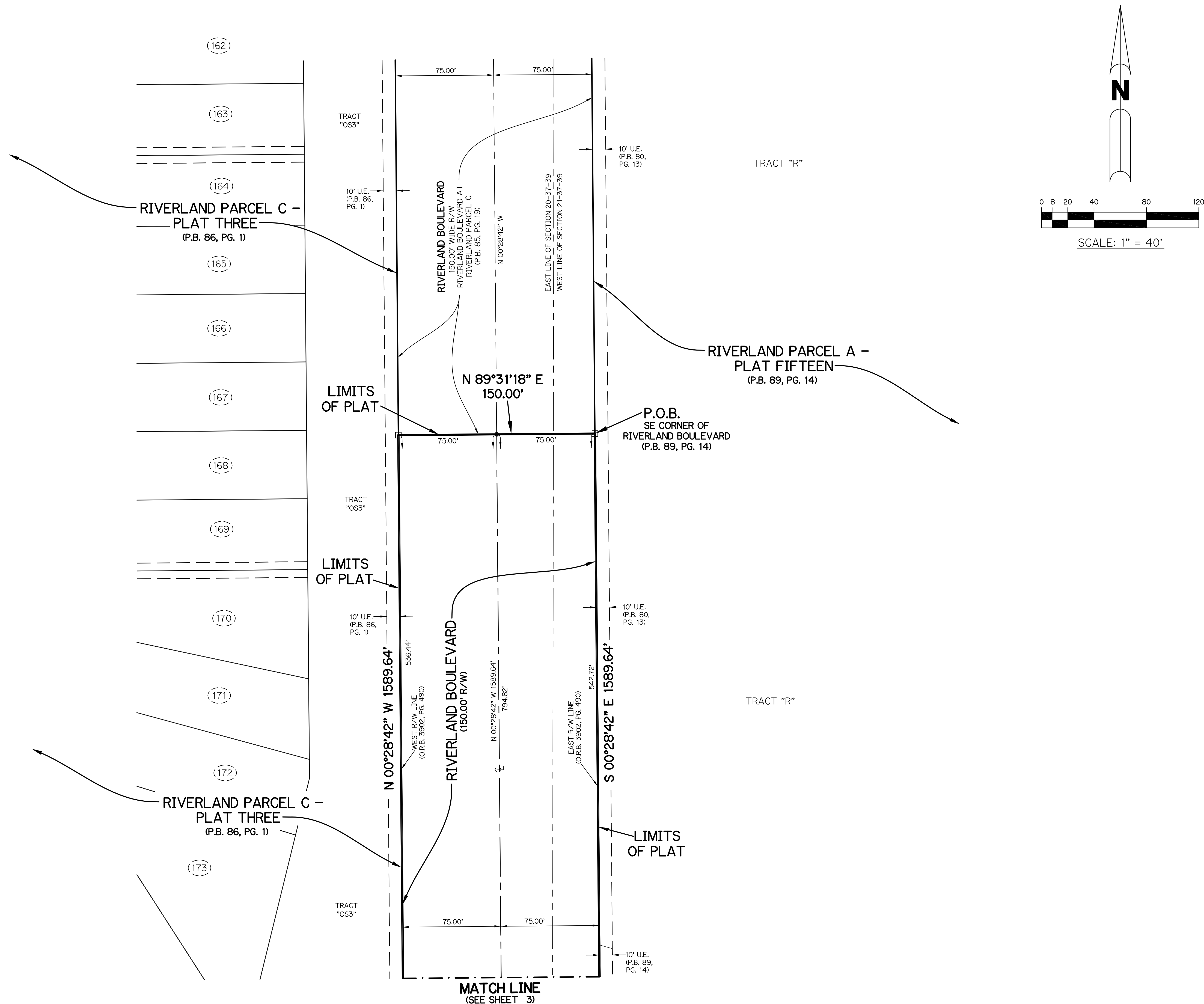

LEGEND:

- - SET PERMANENT REFERENCE MONUMENT
5/8" IRON ROAD WITH 1.5" CAP
STAMPED L.B. #7741
- - FOUND PERMANENT REFERENCE MONUMENT
5/8" IRON ROD WITH 1.5" CAP
STAMPED L.B. #7741
- - SET PERMANENT CONTROL POINT
NAIL WITH 1.25" DISK STAMPED L.B. #7741
- - FOUND PERMANENT CONTROL POINT
NAIL WITH 1.25" DISK STAMPED L.B. #7741
- Δ - DELTA ANGLE
- B.E. - BUFFER EASEMENT
- CB - CHORD BEARING
- CH - CHORD DISTANCE
- C - CENTERLINE
- D.B. - DEED BOOK
- D.E. - DRAINAGE EASEMENT
- D.S.E. - DRAINAGE SWALE EASEMENT
- L - ARC LENGTH
- L.A.E. - LIMITED ACCESS EASEMENT
- L.E. - LANDSCAPE EASEMENT
- L.M.A.E. - LAKE MAINTENANCE ACCESS EASEMENT
- L.M.E. - LAKE MAINTENANCE EASEMENT
- N.R. - NOT RADIAL
- N.T.S. - NOT TO SCALE
- O.R.B. - OFFICIAL RECORD BOOK
- O.E. - MAINTENANCE & ROOF OVERHANG EASEMENT
- P.B. - PLAT BOOK
- P.C.P. - PERMANENT CONTROL POINT
- PGS. - PAGES
- P.O.B. - POINT OF BEGINNING
- P.O.C. - POINT OF COMMENCEMENT
- P.S.L.U.E. - PORT ST. LUCIE UTILITY EASEMENT
- P.S.M. - PROFESSIONAL SURVEYOR AND MAPPER
- R - RADIUS
- R/W - RIGHT-OF-WAY
- S.F. - SQUARE FEET
- S.T. - SURVEY TIE
- U.E. - UTILITY EASEMENT
- U.E.-R.A. - UTILITY EASEMENT-RESTRICTED AREA
- RAD - RADIAL LINE

THIS INSTRUMENT WAS PREPARED BY
PERRY C. WHITE, P.S.M. 4213, STATE OF FLORIDA
SAND & HILLS SURVEYING, INC.
8461 LAKE WORTH ROAD, SUITE 410
LAKE WORTH, FLORIDA 33467
LB-7741

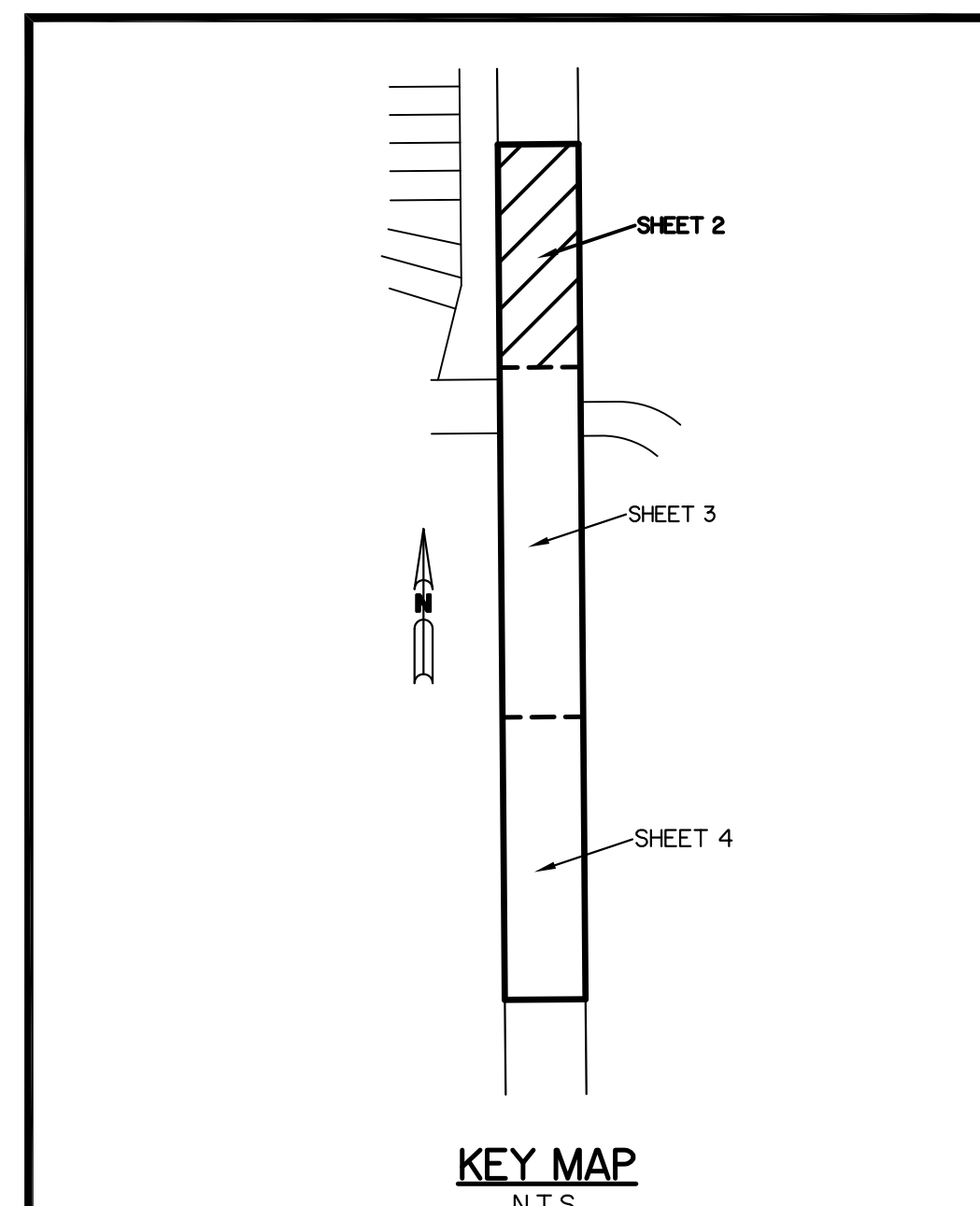

KEY MAP
N.T.S.

RIVERLAND BOULEVARD AT RIVERLAND PASEO OVERPASS

A PARCEL OF LAND LYING IN SECTIONS 20 & 21, TOWNSHIP 37 SOUTH,
RANGE 39 EAST, CITY OF PORT ST. LUCIE, ST. LUCIE COUNTY, FLORIDA

SHEET 3 OF 4

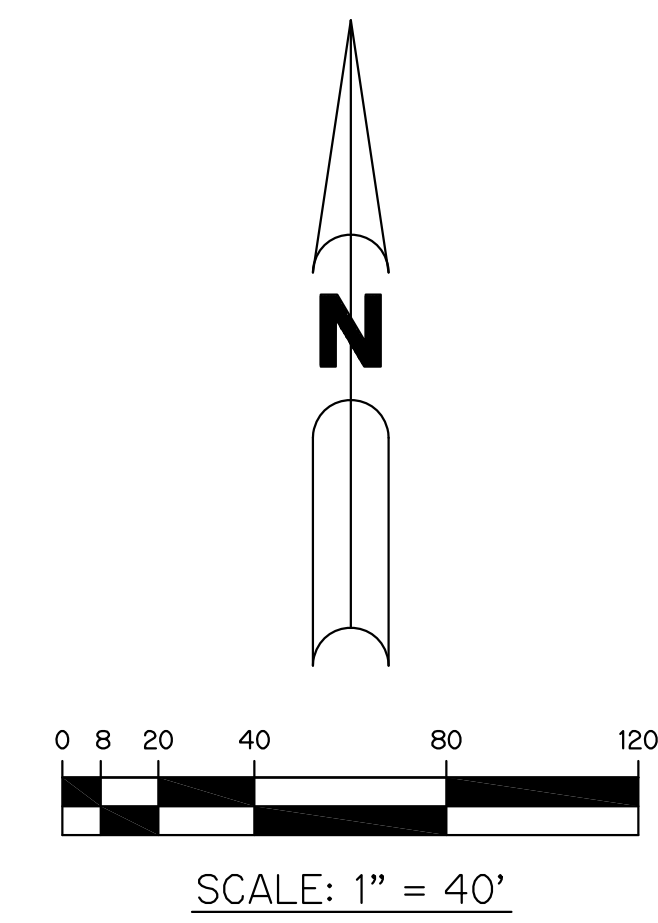
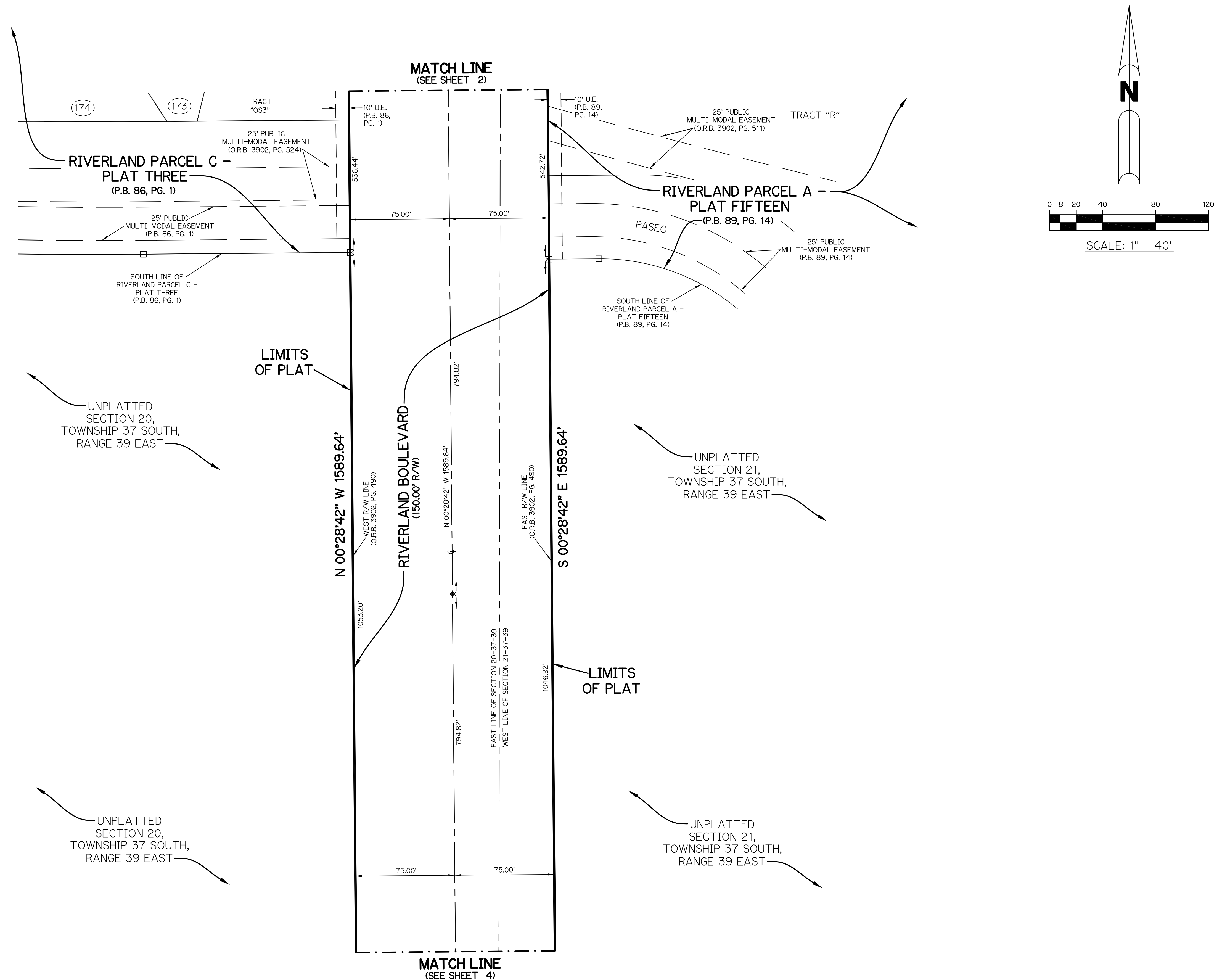

LEGEND:

- - SET PERMANENT REFERENCE MONUMENT
5/8" IRON ROD WITH 1.5" CAP
STAMPED L.B. #7741
- - FOUND PERMANENT REFERENCE MONUMENT
5/8" IRON ROD WITH 1.5" CAP
STAMPED L.B. #7741
- - SET PERMANENT CONTROL POINT
NAIL WITH 1.25" DISK STAMPED L.B. #7741
- - FOUND PERMANENT CONTROL POINT
NAIL WITH 1.25" DISK STAMPED L.B. #7741
- Δ - DELTA ANGLE
- B.E. - BUFFER EASEMENT
- CB - CHORD BEARING
- CH - CHORD DISTANCE
- C. - CENTERLINE
- D.B. - DEED BOOK
- D.E. - DRAINAGE EASEMENT
- D.S.E. - DRAINAGE SWALE EASEMENT
- L - ARC LENGTH
- L.A.E. - LIMITED ACCESS EASEMENT
- L.E. - LANDSCAPE EASEMENT
- L.M.A.E. - LAKE MAINTENANCE ACCESS EASEMENT
- L.M.E. - LAKE MAINTENANCE EASEMENT
- N.R. - NOT RADIAL
- N.T.S. - NOT TO SCALE
- O.R.B. - OFFICIAL RECORD BOOK
- O.E. - MAINTENANCE & ROOF OVERHANG EASEMENT
- P.B. - PLAT BOOK
- P.C.P. - PERMANENT CONTROL POINT
- PGS. - PAGES
- P.O.B. - POINT OF BEGINNING
- P.O.C. - POINT OF COMMENCEMENT
- P.S.L.U.E. - PORT ST. LUCIE UTILITY EASEMENT
- P.S.M. - PROFESSIONAL SURVEYOR AND MAPPER
- R - RADIUS
- R/W - RIGHT-OF-WAY
- S.F. - SQUARE FEET
- S.T. - SURVEY TIE
- U.E. - UTILITY EASEMENT
- U.E.-R.A. - UTILITY EASEMENT-RESTRICTED AREA
- RAD - RADIAL LINE

THIS INSTRUMENT WAS PREPARED BY
PERRY C. WHITE, P.S.M. 4213, STATE OF FLORIDA
SAND & HILLS SURVEYING, INC.
8461 LAKE WORTH ROAD, SUITE 410
LAKE WORTH, FLORIDA 33467
LB-7741

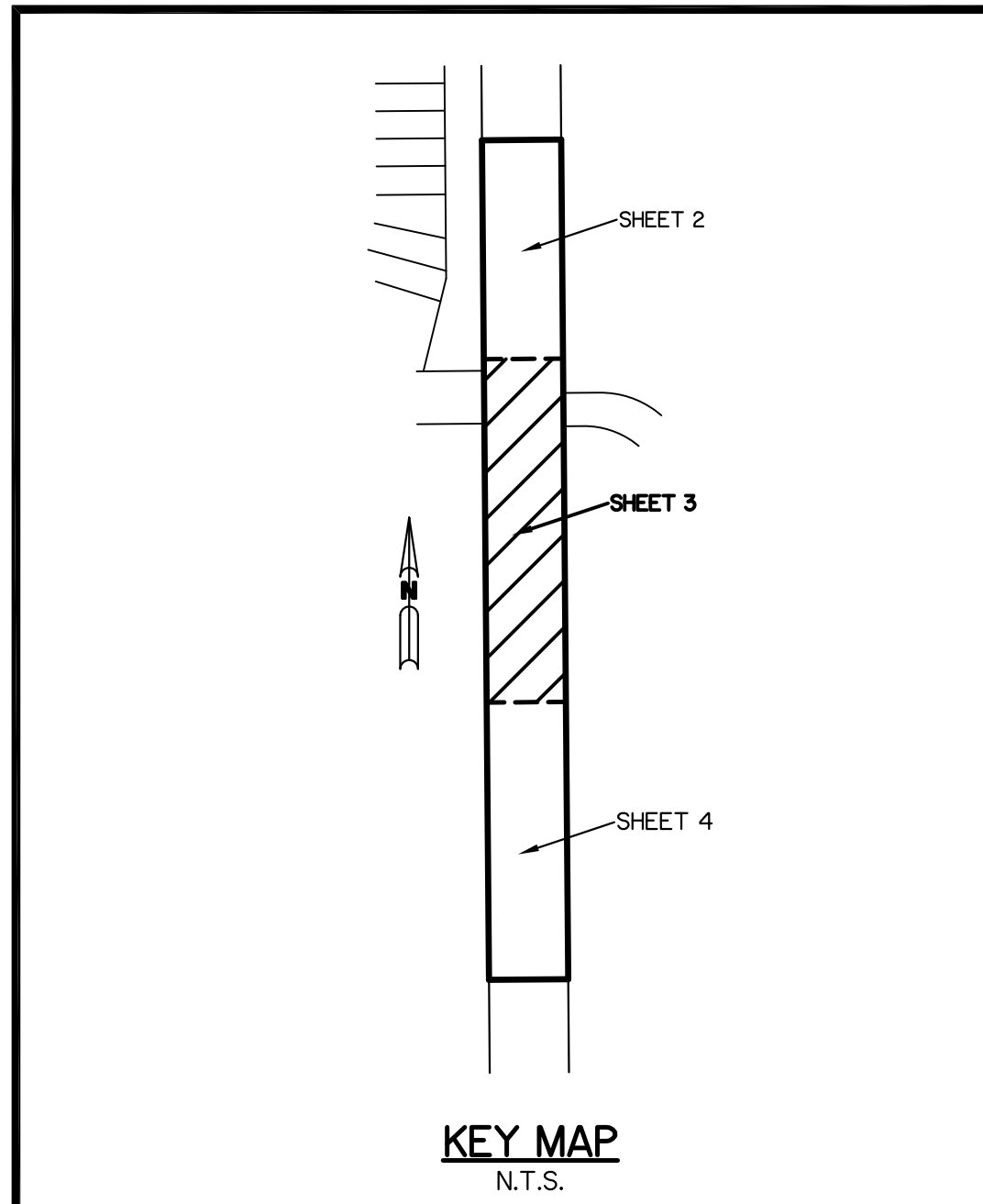

KEY MAP
N.T.S.

RIVERLAND BOULEVARD AT RIVERLAND PASEO OVERPASS

A PARCEL OF LAND LYING IN SECTIONS 20 & 21, TOWNSHIP 37 SOUTH,
RANGE 39 EAST, CITY OF PORT ST. LUCIE, ST. LUCIE COUNTY, FLORIDA

SHEET 4 OF 4

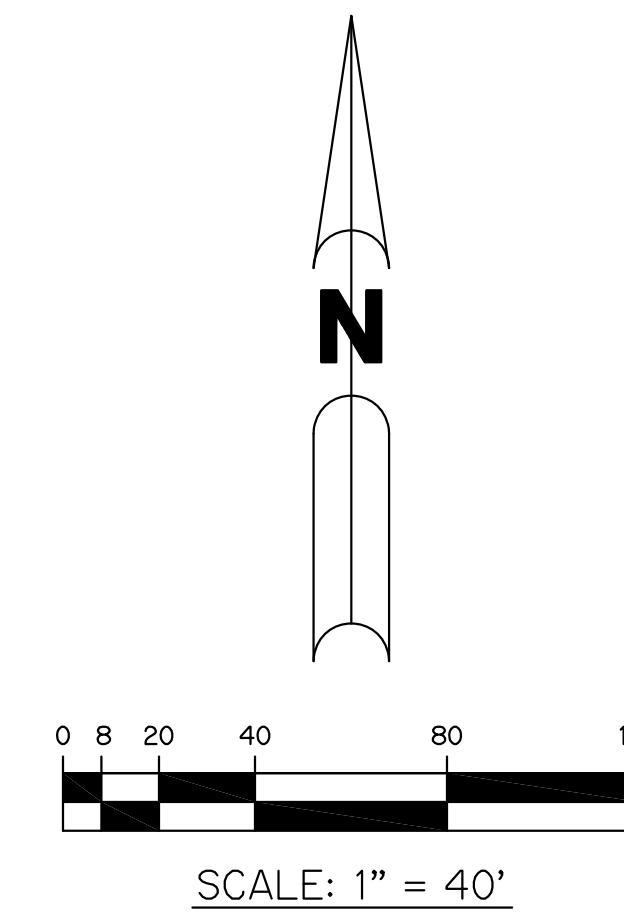
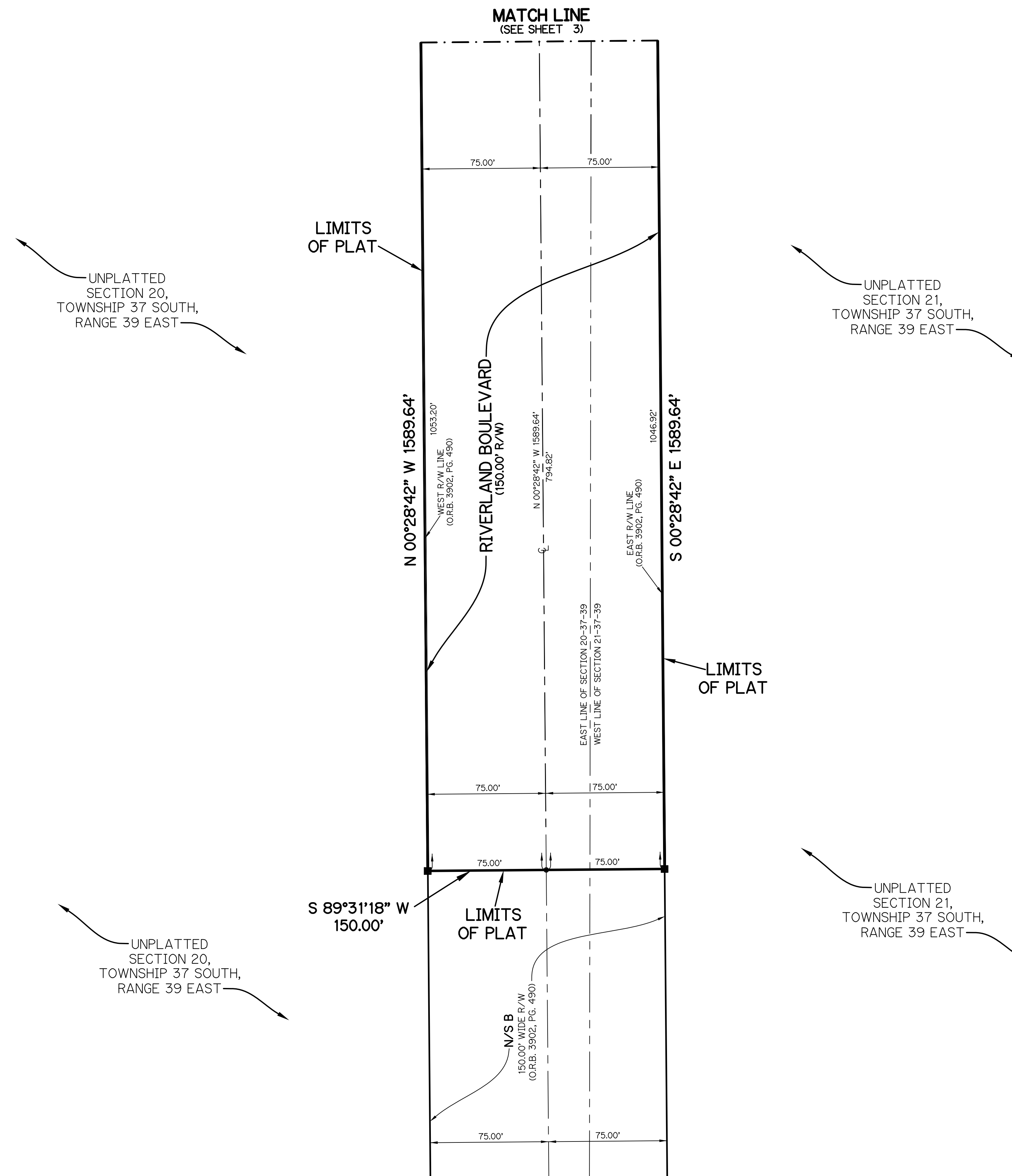

LEGEND:

- - SET PERMANENT REFERENCE MONUMENT
5/8" IRON ROD WITH 1.5" CAP
STAMPED L.B. #7741
- - FOUND PERMANENT REFERENCE MONUMENT
5/8" IRON ROD WITH 1.5" CAP
STAMPED L.B. #7741
- - SET PERMANENT CONTROL POINT
NAIL WITH 1.25" DISK STAMPED L.B. #7741
- - FOUND PERMANENT CONTROL POINT
NAIL WITH 1.25" DISK STAMPED L.B. #7741
- Δ - DELTA ANGLE
- B.E. - BUFFER EASEMENT
- CB - CHORD BEARING
- CH - CHORD DISTANCE
- C. - CENTERLINE
- D.B. - DEED BOOK
- D.E. - DRAINAGE EASEMENT
- D.S.E. - DRAINAGE SWALE EASEMENT
- L - ARC LENGTH
- L.A.E. - LIMITED ACCESS EASEMENT
- L.E. - LANDSCAPE EASEMENT
- L.M.A.E. - LAKE MAINTENANCE ACCESS EASEMENT
- L.M.E. - LAKE MAINTENANCE EASEMENT
- N.R. - NOT RADIAL
- N.T.S. - NOT TO SCALE
- O.R.B. - OFFICIAL RECORD BOOK
- O.E. - MAINTENANCE & ROOF OVERHANG EASEMENT
- P.B. - PLAT BOOK
- P.C.P. - PERMANENT CONTROL POINT
- PGS. - PAGES
- P.O.B. - POINT OF BEGINNING
- P.O.C. - POINT OF COMMENCEMENT
- P.S.L.U.E. - PORT ST. LUCIE UTILITY EASEMENT
- P.S.M. - PROFESSIONAL SURVEYOR AND MAPPER
- R - RADIUS
- R/W - RIGHT-OF-WAY
- S.F. - SQUARE FEET
- S.T. - SURVEY TIE
- U.E. - UTILITY EASEMENT
- U.E.-R.A. - UTILITY EASEMENT-RESTRICTED AREA
- RAD - RADIAL LINE

THIS INSTRUMENT WAS PREPARED BY
PERRY C. WHITE, P.S.M. 4213, STATE OF FLORIDA
SAND & HILLS SURVEYING, INC.
8461 LAKE WORTH ROAD, SUITE 410
LAKE WORTH, FLORIDA 33467
LB-7741

