

PLOTTED BY: johnson, Ben - Sheet - Set: Amazon Glades Cut-Off Road - Lovelock: OVERALL LANDSCAPE January 18, 2022 08:22:11am K:\VREG-URG\LAKELAND\Amazon Glades Cut-Off Road\LANDSCAPE\CADD\Drawings\L-300-OVERALL LANDSCAPE PLAN.dwg
 This document, together with the concepts and designs presented herein, is an instrument of service, as an instrument of service, is intended only for the specific purpose and client for which it was prepared. Reuse of and improper reliance on this document without written authorization and adaptation by Kimley-Horn and Associates, Inc. shall be without liability to Kimley-Horn and Associates, Inc.

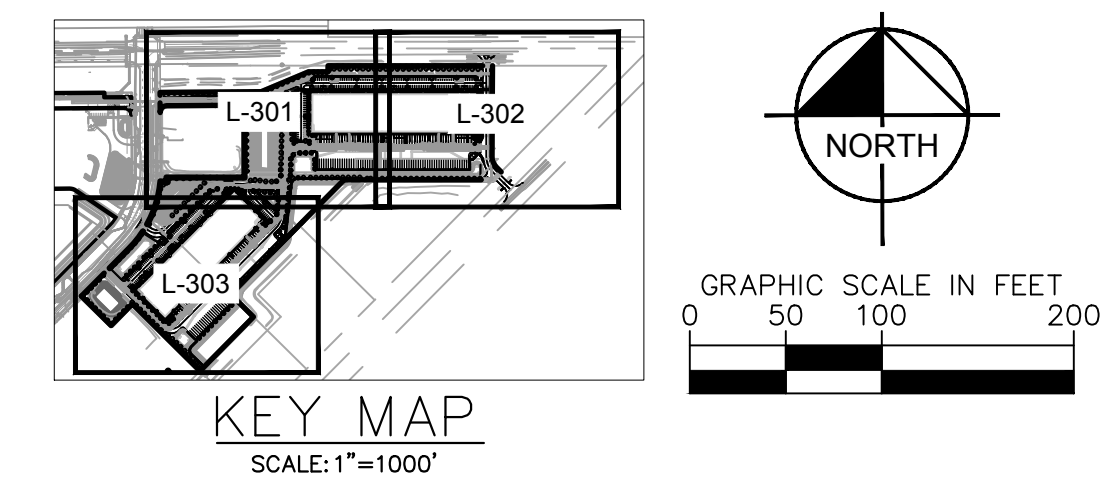
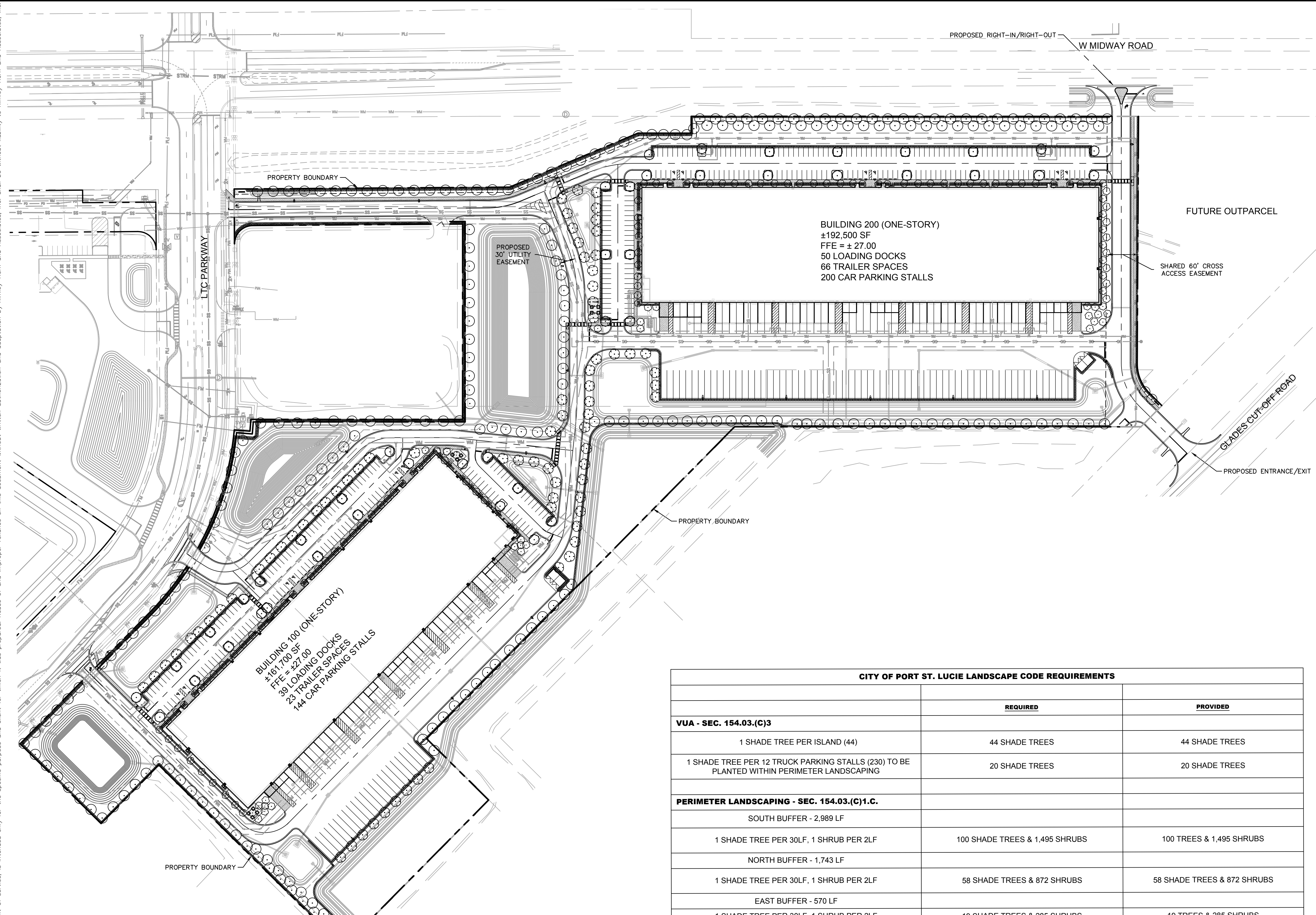

CONCEPT PLANT SCHEDULE

	BUILDING FACADE TREES (8' HT MIN X 1.5" DBH MIN) SIMPSON STOPPER	137
	PALMS (10' CT MIN) THATCH PALM SABAL PALMETTO, CURVED TRUNK ROYAL PALM	9
	PARKING ISLAND (12' HT MIN X 5' CT MIN X 2.5" DBH MIN) GUMBO LIMBO LIVE OAK PIGEON PLUM GREEN BUTTWOOD RED MAPLE SOUTHERN MAGNOLIA	44
	PARKING BUFFER (12' HT MIN X 5' CT MIN X 2.5" DBH MIN) GUMBO LIMBO LIVE OAK PIGEON PLUM GREEN BUTTWOOD RED MAPLE SOUTHERN MAGNOLIA	76
	PERIMETER TREES (12' HT MIN X 5' CT MIN X 2.5" DBH MIN) GUMBO LIMBO BALD CYPRESS LIVE OAK PIGEON PLUM GREEN BUTTWOOD SOUTHERN MAGNOLIA	243
	BUFFER SHRUBS CLUSIA COCOPLUM SIMPSON STOPPER SILVER BUTTWOOD	4,468
	FOUNDATION SHRUB CLUSIA COCOPLUM SIMPSON STOPPER SILVER BUTTWOOD	1,256

CITY OF PORT ST. LUCIE LANDSCAPE CODE REQUIREMENTS		
	REQUIRED	PROVIDED
VUA - SEC. 154.03.(C)3		
1 SHADE TREE PER ISLAND (44)	44 SHADE TREES	44 SHADE TREES
1 SHADE TREE PER 12 TRUCK PARKING STALLS (230) TO BE PLANTED WITHIN PERIMETER LANDSCAPING	20 SHADE TREES	20 SHADE TREES
PERIMETER LANDSCAPING - SEC. 154.03.(C)1.C.		
SOUTH BUFFER - 2,989 LF	100 SHADE TREES & 1,495 SHRUBS	100 TREES & 1,495 SHRUBS
NORTH BUFFER - 1,743 LF	58 SHADE TREES & 872 SHRUBS	58 SHADE TREES & 872 SHRUBS
EAST BUFFER - 570 LF	19 SHADE TREES & 285 SHRUBS	19 TREES & 285 SHRUBS
WEST BUFFER - 1,988 LF	66 SHADE TREES & 1,012 SHRUBS	66 TREES & 1,012 SHRUBS
BUILDING FOUNDATION - SEC. 154.03.(C)2		
1 TREE PER 30LF, 1 SHRUB PER 2LF (4,100 LF)	137 TREES, 2,050 SHRUBS	137 TREES, 2,050 SHRUBS
PERIMETER LANDSCAPING - SEC. 154.04.(C)5-8		
MINIMUM 50% OF ALL REQUIRED TREES TO BE NATIVE	222 TREES	503 TREES
MINIMUM 20% OF ALL REQUIRED TREES TO BE FLOWERING	89 TREES	89 TREES
MINIMUM 75% OF ALL TREES SHALL BE EVERGREEN SHADE TREES	33 TREES	503 TREES
MAXIMUM 25% OF REQUIRED TREES MAY BE PALMS	37 PALMS	3 PALMS
REQUIRED TREE SPECIES MIX	5 SPECIES	5 SPECIES
MINIMUM 25% OF ALL REQUIRED SHRUBS TO BE NATIVE	1,429 SHRUBS	5,851 SHRUBS
TOTAL TREES:	444 TREES REQUIRED	503 TREES PROVIDED
TOTAL SHRUBS:	5,714 SHRUBS REQUIRED	5,724 SHRUBS PROVIDED

- LANDSCAPE NOTES:**
- ALL LANDSCAPE MATERIAL TO BE FLORIDA GRADE #1 OR BETTER QUALITY
 - ALL LANDSCAPED AREAS ARE TO RECEIVE A MINIMUM OF 4" OF TOPSOIL
 - ALL PLANT MATERIAL SHALL BE HEALTHY, VIGOROUS, AND FREE OF PESTS AND DISEASE
 - ALL MATERIALS ARE SUBJECT TO THE APPROVAL OF THE LANDSCAPE ARCHITECT BEFORE, DURING, AND AFTER INSTALLATION
 - ALL TREES MUST BE GUYED OR STAKED AS SHOWN IN THE DETAILS
 - ALL PLANTING AREAS SHALL BE COMPLETELY MULCHED AS SPECIFIED
 - PRIOR TO CONSTRUCTION, THE CONTRACTOR SHALL BE RESPONSIBLE FOR LOCATING ALL UNDERGROUND UTILITIES (CONTACT SUNSHINE STATE ONE-CALL FOR LOCATES) AND SHALL AVOID DAMAGE TO ALL UTILITIES DURING THE COURSE OF THE WORK. LOCATIONS OF EXISTING BURIED UTILITY LINES SHOWN ON THE PLANS ARE BASED UPON BEST AVAILABLE INFORMATION AND ARE TO BE CONSIDERED APPROXIMATE. IT SHALL BE THE RESPONSIBILITY OF THE CONTRACTOR 1) TO VERIFY THE LOCATIONS OF UTILITY LINES AND ADJACENT TO THE WORK AREA 2) TO PROTECT OF ALL UTILITY LINES DURING THE CONSTRUCTION PERIOD 3) TO REPAIR ANY AND ALL DAMAGE TO UTILITIES, STRUCTURES, SITE APPURTENANCES, ETC. WHICH OCCURS AS A RESULT OF THE CONSTRUCTION
 - THE CONTRACTOR SHALL BE RESPONSIBLE FOR VERIFYING ALL QUANTITIES SHOWN ON THESE PLANS BEFORE PRICING THE WORK
 - CONTRACTOR SHALL BE RESPONSIBLE FOR DELIVERY SCHEDULE AND PROTECTION BETWEEN DELIVERY AND PLANTING TO MAINTAIN HEALTHY PLANT CONDITIONS
 - THE CONTRACTOR SHALL BE RESPONSIBLE FOR FULLY MAINTAINING (INCLUDING BUT NOT LIMITED TO: WATERING, SPRAYING, MULCHING, FERTILIZING, ETC.) ALL OF THE PLANT MATERIALS AND LAWN FOR THE WARRANTY PERIOD
 - ANY PLANT MATERIAL WHICH IS DISEASED, DISTRESSED, DEAD, OR REJECTED (PRIOR TO SUBSTANTIAL COMPLETION) SHALL BE PROMPTLY REMOVED FROM THE SITE AND REPLACED WITH MATERIAL OF THE SAME SPECIES, QUANTITY, AND SIZE AND MEETING ALL PLANT LIST SPECIFICATIONS
 - THE CONTRACTOR SHALL COMPLETELY GUARANTEE ALL PLANT MATERIAL FOR WARRANTY PERIOD. THE CONTRACTOR SHALL PROMPTLY MAKE ALL REPLACEMENTS DURING THE NORMAL PLANTING SEASON. STANDARDS SET FORTH IN "AMERICAN STANDARD FOR NURSERY STOCK" REPRESENT GUIDELINE SPECIFICATIONS ONLY AND SHALL CONSTITUTE MINIMUM QUALITY REQUIREMENTS FOR PLANT MATERIAL
 - ALL LANDSCAPING SHALL BE INSTALLED ACCORDING TO SOUND NURSERY PRACTICES, AND SHALL BE FLORIDA NO. 1 OR BETTER AS GIVEN IN "GRADES AND STANDARDS FOR NURSERY PLANTS, PARTS I AND II," STATE OF FLORIDA, DEPARTMENT OF AGRICULTURE
 - ALL INVASIVE / EXOTIC SPECIES AND PROHIBITED TREE SPECIES SHALL BE REMOVED FROM SITE, INCLUDING ROOT BALLS TO THE EXTENT POSSIBLE WITH NO DAMAGE TO ADJACENT EXISTING TREES
 - ALL LANDSCAPE AREAS WILL BE PROVIDED WITH PERMANENT AUTOMATIC IRRIGATION SYSTEM
 - TREE SUPPORT MATERIALS ARE TO BE REMOVED FROM EACH TREE ONCE IT IS "ESTABLISHED" (AS APPROVED BY THE LANDSCAPE ARCHITECT)
 - ALL PLANT SPECIFICATIONS IN THE PLANT SCHEDULE SHALL BE CONSIDERED THE MINIMUM ALLOWABLE SPECIFICATIONS. CONTRACTOR SHALL PROCURE PLANT MATERIALS AND UPSIZE AS NECESSARY TO MEET THE MOST STRINGENT SPECIFICATION
 - CONTRACTOR SHALL PROVIDE ROOT BARRIER IN ALL INSTANCES WHERE PROPOSED TREES ARE WITHIN 5 FEET OF ANY DRAINAGE UTILITIES
 - NO LANDSCAPING SHALL BE PLANTED IN A MANNER THAT WOULD ADVERSELY AFFECT UTILITY EASEMENTS. LANDSCAPING SHALL BE IN COMPLIANCE WITH CHAPTER 153 OF THE CITY OF PORT ST. LUCIE CODE OF ORDINANCES, PSLUSD TECHNICAL SPECIFICATIONS, POLICIES, AND CODES
 - ALL LANDSCAPING WITHIN CITY UTILITY EASEMENTS SHALL COMPLY WITH PSLUSD TECHNICAL SPECIFICATIONS, POLICIES, AND CODES
 - ALL LANDSCAPING SHALL MEET THE LATEST PSLUSD LANDSCAPE POLICY AND SHALL NOT BE PLACED IN A MANNER THAT WOULD CREATE CONFLICTS WITH THE INTENDED OPERATION AND MAINTENANCE OF ANY EXISTING UTILITY
 - TREES SHALL NOT BE PLANTED WITHIN TEN (10) FEET OF ANY PSLUSD UNDERGROUND INFRASTRUCTURE
 - NO LANDSCAPING OTHER THAN SOD GRASES SHALL BE LOCATED WITHIN 5' OF A PSLUSD SEWER CLEANOUT, ETC.
 - NOTHING SHALL BE LOCATED, ERECTED, PLACED, PLANTED, OR ALLOWED TO GROW IN SUCH A MANNER AS TO IMPEDE VISION BETWEEN A HEIGHT OF THREE (3) FEET AND EIGHT (8) FEET WITHIN THE PARKING AREAS
 - ALL LANDSCAPED PARKING ISLANDS SHALL BE SODDED
 - ALL PROPOSED TREE, SHRUB, AND GROUND COVER AREAS SHALL USE BE PLANTED IN A ROCK BED.

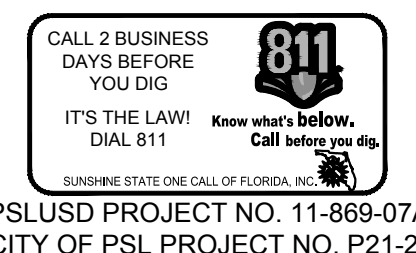

THIS ITEM HAS BEEN DIGITALLY SIGNED AND SEALED BY BENJAMIN V. JOHNSON, P.L.A., ON THE DATE ADJACENT TO THE SEAL.

PRINTED COPIES OF THIS DOCUMENT ARE NOT CONSIDERED SIGNED AND SEALED AND THE SIGNATURE MUST BE VERIFIED ON ANY ELECTRONIC COPIES.

Kimley-Horn

© 2021 KIMLEY-HORN AND ASSOCIATES, INC.
 1615 S. CONGRESS AVE. SUITE 201,
 DELRAY BEACH, FL 33445
 PHONE: 561-330-2345 FAX: 561-863-8175
 WWW.KIMLEY-HORN.COM REGISTRY NO. 696

KHA PROJECT 046265028
 DATE 10/19/2021
 SCALE AS SHOWN
 DESIGNED BY
 DRAWN BY
 CHECKED BY

BENJAMIN V. JOHNSON
 STATE OF FLORIDA
 PROFESSIONAL LANDSCAPE ARCHITECT
 No. LL6667524

OVERALL LANDSCAPE PLAN



PROJECT GLADES PREPARED FOR SEEFRED INDUSTRIAL PROPERTIES, INC.

CITY OF PORT ST. LUCIE FLORIDA

SHEET NUMBER L-300

Plotted By: Johnson, Ben Sheet: Set: Amazon Glades Cut-Off Road Layout: 301 LANDSCAPE January 15, 2022 08:23:15am K:\ORG-URG\AKELAND\amazon glades cut-off\landscape\CADD\plansheets\L-301 LANDSCAPE PLAN.dwg
 This document, together with the concepts and designs presented herein, is intended only for the specific purpose and client for which it was prepared. Reuse of and improper reliance on this document without written authorization and adaptation by Kimley-Horn and Associates, Inc. shall be without liability to Kimley-Horn and Associates, Inc.

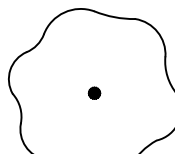
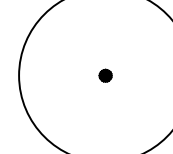
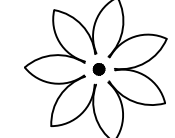
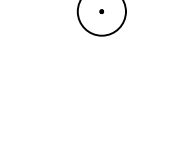
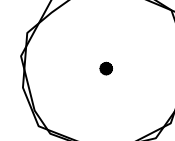
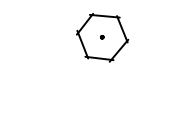
CONCEPT KEY

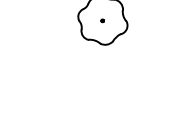
- | | | | |
|---|---|---|---|
|  | BUILDING FACADE TREES
SIMPSON STOPPER |  | PERIMETER TREES
GUMBO LIMBO
BALD CYPRESS
LIVE OAK
PIGEON PLUM
GREEN BUTTONWOOD
SOUTHERN MAGNOLIA |
|  | PALMS
THATCH PALM
SABAL PALMETTO, CURVED TRUNK
ROYAL PALM |  | BUFFER SHRUBS
CLUSIA
COCOPLUM
SIMPSON STOPPER
SILVER BUTTONWOOD |
|  | PARKING ISLAND
GUMBO LIMBO
LIVE OAK
PIGEON PLUM
GREEN BUTTONWOOD
RED MAPLE
SOUTHERN MAGNOLIA |  | FOUNDATION SHRUB
CLUSIA
COCOPLUM
SIMPSON STOPPER
SILVER BUTTONWOOD |
|  | PARKING BUFFER
GUMBO LIMBO
LIVE OAK
PIGEON PLUM
GREEN BUTTONWOOD
RED MAPLE
SOUTHERN MAGNOLIA |  | PARKING BUFFER SHRUB
CLUSIA
COCOPLUM
SIMPSON STOPPER
SILVER BUTTONWOOD |

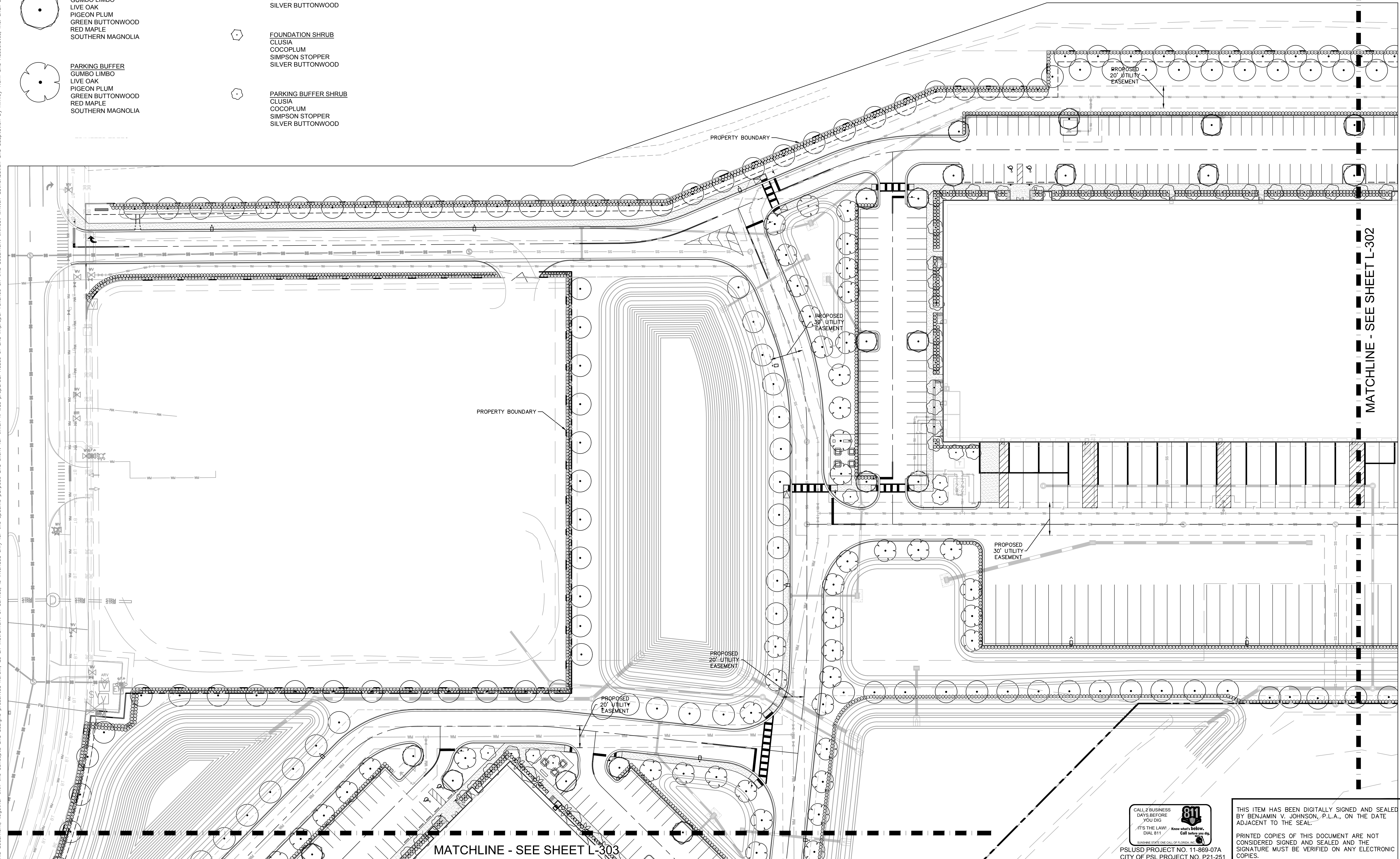
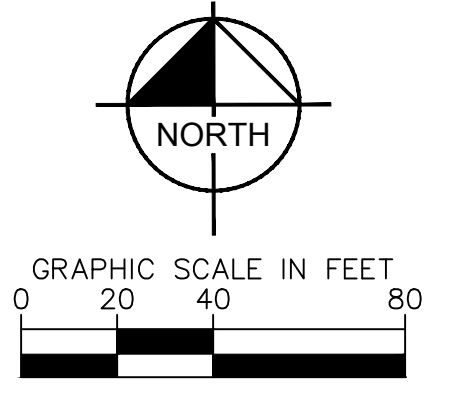
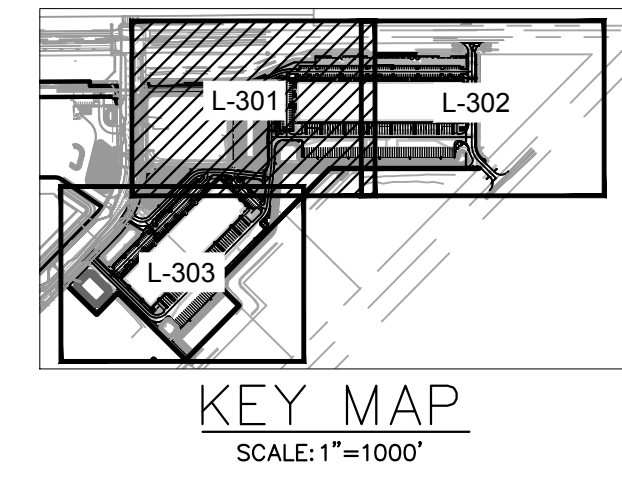

MATCHLINE - SEE SHEET L-302

MATCHLINE - SEE SHEET L-303

NO.	REVISIONS	DATE	BY

Kimley»Horn

© 2021 KIMLEY-HORN AND ASSOCIATES, INC.
 1615 S. CONGRESS AVE. SUITE 201,
 DELRAY BEACH, FL 33445
 PHONE: 561-330-2345 FAX: 561-863-8175
 WWW.KIMLEY-HORN.COM REGISTRY NO. 696

BENJAMIN VAN JOHNSON
 No. 116667524
 STATE OF FLORIDA
 PROFESSIONAL LANDSCAPE ARCHITECT

KHA PROJECT	046265028
DATE	10/19/2021
SCALE	AS SHOWN
DESIGNED BY	
DRAWN BY	
CHECKED BY	

LANDSCAPE PLAN

PROJECT GLADES
 PREPARED FOR
 SEEFRIED INDUSTRIAL
 PROPERTIES, INC.
 CITY OF PORT ST.
 LUCIE
 FLORIDA

SHEET NUMBER
L-301

CALL 2 BUSINESS DAYS BEFORE YOU DIG
 IT'S THE LAW! DIAL 811
 Know what's below! Call before you dig.
 811
 SUBMITTER STATE ONE CALL OF FLORIDA, INC.

THIS ITEM HAS BEEN DIGITALLY SIGNED AND SEALED BY BENJAMIN V. JOHNSON, P.L.A., ON THE DATE ADJACENT TO THE SEAL.

PRINTED COPIES OF THIS DOCUMENT ARE NOT CONSIDERED SIGNED AND SEALED AND THE SIGNATURE MUST BE VERIFIED ON ANY ELECTRONIC COPIES.

Plotted By: johnson, Ben Sheet: Set: Amazon Glades Cut-Off Road Layout: 302_LANDSCAPE January 18, 2022 08:23:30am K:\GRC\URC\LAKELAND\amazon_glades_cut_off\landscape\CADD\plan\301_LANDSCAPE_PLAN.dwg
 This document, together with the concepts and designs presented herein, is intended only for the specific purpose and client for which it was prepared. Reuse of and improper reliance on this document without written authorization and adaptation by Kimley-Horn and Associates, Inc. shall be without liability to Kimley-Horn and Associates, Inc.

MATCHLINE - SEE SHEET L-301

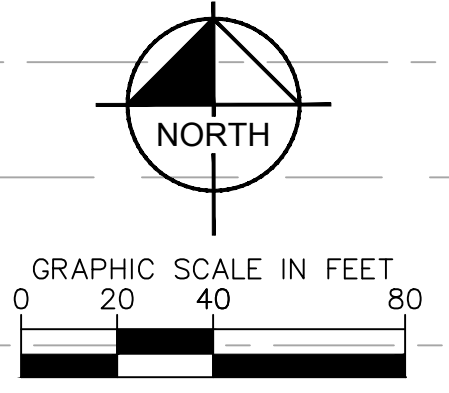
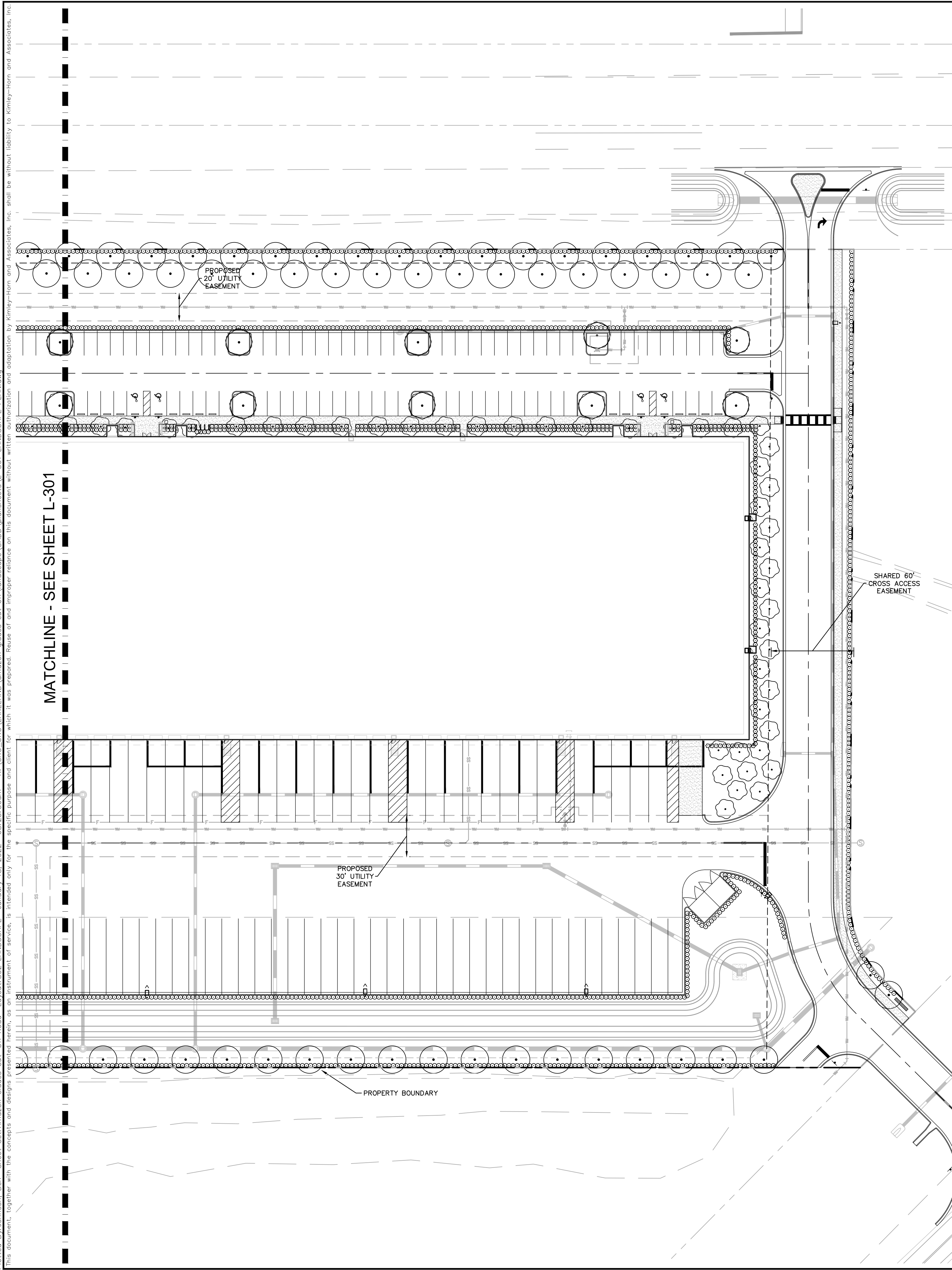

CONCEPT KEY

- BUILDING FACADE TREES
SIMPSON STOPPER
- PALMS
THATCH PALM
SABAL PALMETTO, CURVED TRUNK
ROYAL PALM
- PARKING ISLAND
GUMBO LIMBO
LIVE OAK
PIGEON PLUM
GREEN BUTTWOOD
RED MAPLE
SOUTHERN MAGNOLIA
- PARKING BUFFER
GUMBO LIMBO
LIVE OAK
PIGEON PLUM
GREEN BUTTWOOD
RED MAPLE
SOUTHERN MAGNOLIA
- PERIMETER TREES
GUMBO LIMBO
BALD CYPRESS
LIVE OAK
PIGEON PLUM
GREEN BUTTWOOD
SOUTHERN MAGNOLIA
- BUFFER SHRUBS
CLUSIA
COCOPLUM
SIMPSON STOPPER
SILVER BUTTWOOD
- FOUNDATION SHRUB
CLUSIA
COCOPLUM
SIMPSON STOPPER
SILVER BUTTWOOD
- PARKING BUFFER SHRUB
CLUSIA
COCOPLUM
SIMPSON STOPPER
SILVER BUTTWOOD

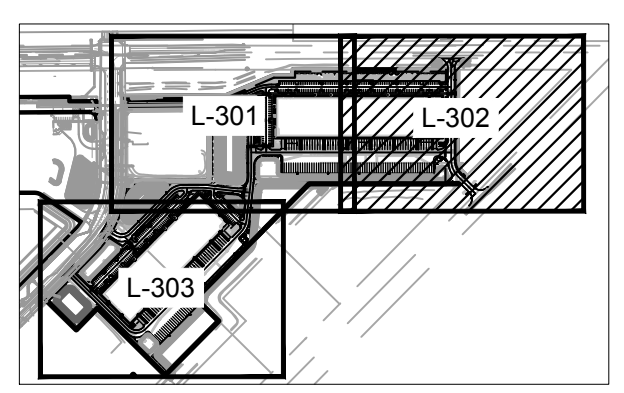

KEY MAP
SCALE: 1"=1000'



THIS ITEM HAS BEEN DIGITALLY SIGNED AND SEALED BY BENJAMIN V. JOHNSON, P.L.A., ON THE DATE ADJACENT TO THE SEAL.
 PRINTED COPIES OF THIS DOCUMENT ARE NOT CONSIDERED SIGNED AND SEALED AND THE SIGNATURE MUST BE VERIFIED ON ANY ELECTRONIC COPIES.

No.	REVISIONS	DATE	BY

Kimley»Horn
 © 2021 KIMLEY-HORN AND ASSOCIATES, INC.
 1615 S. CONGRESS AVE. SUITE 201,
 DELRAY BEACH, FL 33445
 PHONE: 561-330-2345 FAX: 561-863-8175
 WWW.KIMLEY-HORN.COM REGISTRY NO. 696

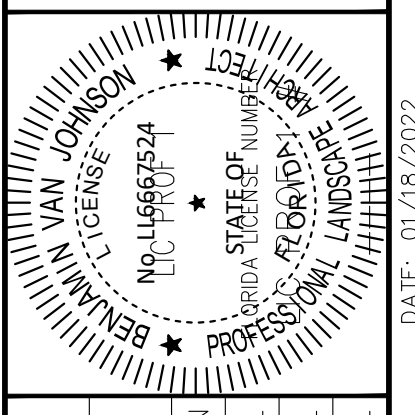

KHA PROJECT 046265028	DATE 10/19/2021
SCALE AS SHOWN	DESIGNED BY
	DRAWN BY
	CHECKED BY

LANDSCAPE PLAN

PROJECT GLADES
 PREPARED FOR
**SEEFRED INDUSTRIAL
 PROPERTIES, INC.**
 CITY OF PORT ST.
 LUCIE FLORIDA

SHEET NUMBER
L-302

CALL 2 BUSINESS DAYS BEFORE YOU DRO
 IT'S THE LAW! DIAL 911
 Know what 311 means? Call before you dip.
 SUNSHINE STATE ONE CALL OF FLORIDA, INC.
 PSLUSD PROJECT NO. 11-869-07A
 CITY OF PSL PROJECT NO. P21-251

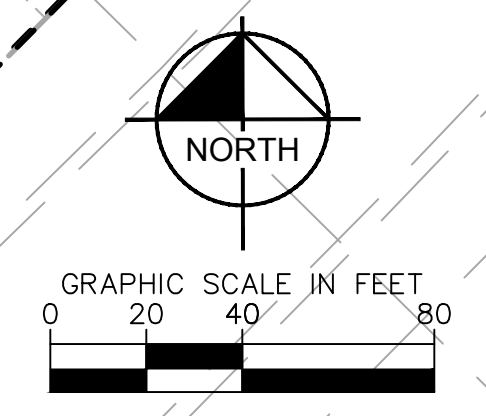
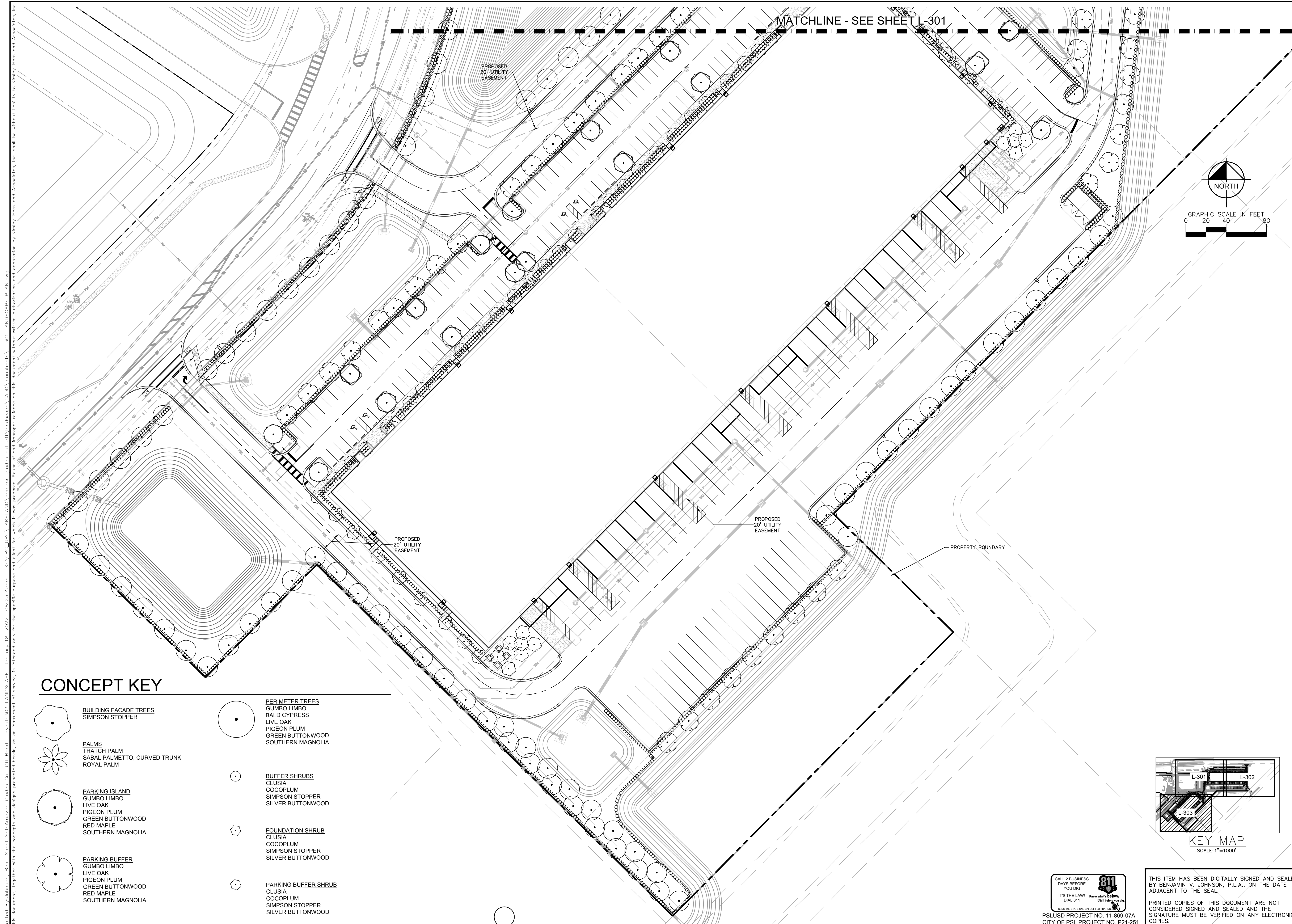

CONCEPT KEY

- | | | | |
|--|---|--|---|
| | BUILDING FACADE TREES
SIMPSON STOPPER | | PERIMETER TREES
GUMBO LIMBO
BALD CYPRESS
LIVE OAK
PIGEON PLUM
GREEN BUTTWOOD
SOUTHERN MAGNOLIA |
| | PALMS
THATCH PALM
SABAL PALMETTO, CURVED TRUNK
ROYAL PALM | | BUFFER SHRUBS
CLUSIA
COCOPLUM
SIMPSON STOPPER
SILVER BUTTWOOD |
| | PARKING ISLAND
GUMBO LIMBO
LIVE OAK
PIGEON PLUM
GREEN BUTTWOOD
RED MAPLE
SOUTHERN MAGNOLIA | | FOUNDATION SHRUB
CLUSIA
COCOPLUM
SIMPSON STOPPER
SILVER BUTTWOOD |
| | PARKING BUFFER
GUMBO LIMBO
LIVE OAK
PIGEON PLUM
GREEN BUTTWOOD
RED MAPLE
SOUTHERN MAGNOLIA | | PARKING BUFFER SHRUB
CLUSIA
COCOPLUM
SIMPSON STOPPER
SILVER BUTTWOOD |

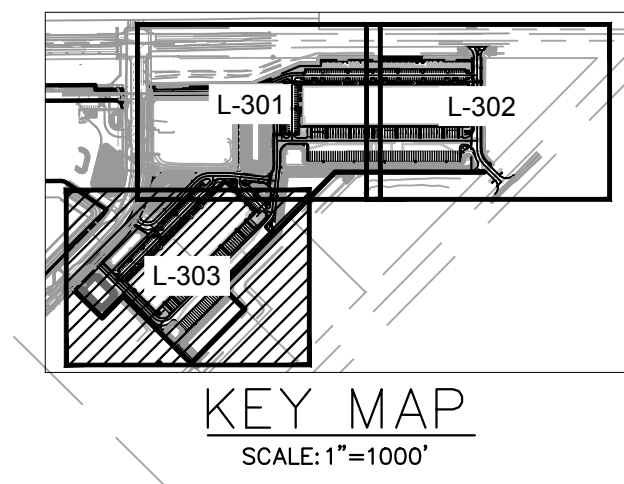

CALL 2 BUSINESS DAYS BEFORE YOU DIE!
IT'S THE LAW! DIAL 811
Know what's below! Call before you dig.
SUNSHINE STATE ONE CALL OF FLORIDA, INC.
PSLUSD PROJECT NO. 11-869-07A
CITY OF PSL PROJECT NO. P21-251

THIS ITEM HAS BEEN DIGITALLY SIGNED AND SEALED BY BENJAMIN V. JOHNSON, P.L.A., ON THE DATE ADJACENT TO THE SEAL.
PRINTED COPIES OF THIS DOCUMENT ARE NOT CONSIDERED SIGNED AND SEALED AND THE SIGNATURE MUST BE VERIFIED ON ANY ELECTRONIC COPIES.

Plotted By: johnson, Ben Sheet: Set: Amazon Glades Cut-Off Road Layout: 303 LANDSCAPE January 18, 2022 08:23:45am K:\GRC\URC\LAKELAND\amazon glades cut off\landscape\CADD\plan\sheet\303 LANDSCAPE PLAN.dwg
 This document, together with the concepts and designs presented herein, is an instrument of service. It is intended only for the specific purpose and client for which it was prepared. Reuse of and improper reliance on this document without written authorization and adaptation by Kimley-Horn and Associates, Inc. shall be without liability to Kimley-Horn and Associates, Inc.

<p>© 2021 KIMLEY-HORN AND ASSOCIATES, INC. 1615 S. CONGRESS AVE. SUITE 201, DELRAY BEACH, FL 33445 PHONE: 561-330-2345 FAX: 561-863-8175 WWW.KIMLEY-HORN.COM REGISTRY NO. 696</p>		No.	REVISIONS	DATE	BY
<p>KHA PROJECT 046265028</p> <p>DATE 10/19/2021</p> <p>SCALE AS SHOWN</p> <p>DESIGNED BY</p> <p>DRAWN BY</p> <p>CHECKED BY</p>					
<p>PROJECT GLADES PREPARED FOR SEEFRED INDUSTRIAL PROPERTIES, INC.</p> <p>CITY OF PORT ST. LUCIE FLORIDA</p>		<p>LANDSCAPE PLAN</p>			
<p>SHEET NUMBER L-303</p>		<p>DATE: 07/18/2022</p>			

Plotted by: johnson, Ben Sheet: See: Amazon Glades Cut - Off Road Layout: Spaces January 15, 2022, 08:23:52pm K:\CRO-URC\LAKE\AND\Amazon Glades cut off\landscapes\CADD\plansheets\L-350 LANDSCAPE SPECS AND DETAILS.dwg
 This document, together with the concepts and designs presented herein, is intended only for the specific purpose and client for which it was prepared. Reuse of and improper reliance on this document without written authorization and adaptation by Kimley-Horn and Associates, Inc. shall be without liability to Kimley-Horn and Associates, Inc.

GENERAL LANDSCAPE SPECIFICATIONS AND NOTES

A. SCOPE OF WORK

1. THE WORK CONSISTS OF: FURNISHING ALL LABOR, MATERIALS, EQUIPMENT, TOOLS, TRANSPORTATION, AND ANY OTHER APPURTENANCES NECESSARY FOR THE COMPLETION OF THIS PROJECT AS SHOWN ON THE DRAWINGS, AS INCLUDED IN THE PLANT LIST, AND AS HEREIN SPECIFIED.
2. WORK SHALL INCLUDE MAINTENANCE AND WATERING OF ALL CONTRACT PLANTING AREAS UNTIL CERTIFICATION OF ACCEPTABILITY BY THE OWNER.

B. PROTECTION OF EXISTING STRUCTURES

1. ALL EXISTING BUILDINGS, WALKS, WALLS, PAVING, PIPING, OTHER SITE CONSTRUCTION ITEMS, AND PLANTING ALREADY COMPLETED OR ESTABLISHED SHALL BE PROTECTED FROM DAMAGE BY THE CONTRACTOR UNLESS OTHERWISE SPECIFIED. ALL DAMAGE RESULTING FROM NEGLIGENCE SHALL BE REPAIRED OR REPLACED TO THE SATISFACTION OF THE OWNER, AT NO COST TO THE OWNER.

C. PROTECTION OF EXISTING PLANT MATERIALS OUTSIDE LIMIT OF WORK

1. THE CONTRACTOR SHALL BE RESPONSIBLE FOR ALL UNAUTHORIZED CUTTING OR DAMAGE TO TREES AND SHRUBS EXISTING OR OTHERWISE, CAUSED BY CARELESS EQUIPMENT OPERATION, MATERIAL STOCKPILING, ETC. THIS SHALL INCLUDE COMPACTION BY DRIVING OR PARKING INSIDE THE DRIP-LINE AND SPILLING OIL, GASOLINE, OR OTHER DELETERIOUS MATERIALS WITHIN THE DRIP-LINE. NO MATERIALS SHALL BE BURNED WHERE HEAT WILL DAMAGE ANY PLANT. EXISTING TREES KILLED OR DAMAGED SO THAT THEY ARE MISSHAPEN AND/ OR UNSIGHTLY SHALL BE REPLACED AT THE COST TO THE CONTRACTOR OF ONE HUNDRED DOLLARS (\$100) PER CALIPER INCH ON AN ESCALATING SCALE WHICH ADDS AN ADDITIONAL TWENTY (20) PERCENT PER INCH OVER FOUR (4) INCHES CALIPER AS FIXED AND AGREED LIQUIDATED DAMAGES. CALIPER SHALL BE MEASURED SIX (6) INCHES ABOVE GROUND LEVEL FOR TREES UP TO AND INCLUDING FOUR (4) INCH CALIPER AND TWELVE (12) INCHES ABOVE GROUND LEVEL FOR TREES OVER FOUR (4) INCH CALIPER.

D. MATERIALS

1. GENERAL

- a. MATERIALS LISTED BELOW SHALL BE SUBMITTED FOR APPROVAL UPON SUBMITTALS' APPROVAL. DELIVERY OF MATERIALS MAY COMMENCE.

MATERIAL	SUBMITTAL
MULCH	PRODUCT DATA
TOPSOIL MIX	AMENDMENT MIX/ PRODUCT DATA/ TEST RESULTS
PLANTS	PHOTOGRAPHS OF ONE (1) OF EACH SPECIES (OR TAGGED IN NURSERY) INDICATE SIZES (HEIGHT/WIDTH) AND QUALITY PER SPEC. CLIENT REQUESTED TAGGING MAY SUBSTITUTE PHOTOS.
FERTILIZER	PRODUCT DATA
INNOCULANT	PRODUCT DATA
HERBICIDE	PRODUCT DATA

2. PLANT MATERIALS

- a. PLANT SPECIES AND SIZE SHALL CONFORM TO THOSE INDICATED ON THE DRAWINGS. NOMENCLATURE SHALL CONFORM TO STANDARDIZED PLANT NAMES, 1942 EDITION. ALL NURSERY STOCK SHALL BE IN ACCORDANCE WITH GRADES AND STANDARDS FOR NURSERY PLANTS, LATEST EDITION, PUBLISHED BY THE FLORIDA DEPARTMENT OF AGRICULTURE AND CONSUMER SERVICES. ALL PLANTS SHALL BE FLORIDA GRADE NO. 1 OR BETTER AS DETERMINED BY THE FLORIDA DIVISION OF PLANT INDUSTRY. ALL PLANTS SHALL BE HEALTHY, VIGOROUS, SOUND, WELL-BRANCHED, AND FREE OF DISEASE AND INSECTS, INSECT EGGS AND LARVAE AND SHALL HAVE ADEQUATE ROOT SYSTEMS. TREES FOR PLANTING IN ROWS SHALL BE UNIFORM IN SIZE AND SHAPE. ALL MATERIALS SHALL BE SUBJECT TO APPROVAL BY THE OWNER. WHERE ANY REQUIREMENTS ARE OMITTED FROM THE PLANT LIST, THE PLANTS FURNISHED SHALL BE NORMAL FOR THE VARIETY. PLANTS SHALL BE PRUNED PRIOR TO DELIVERY ONLY WITH APPROVAL FROM OWNER OR OWNER'S REPRESENTATIVE. NO SUBSTITUTIONS SHALL BE MADE WITHOUT WRITTEN PERMISSION FROM THE OWNER'S REPRESENTATIVE.
- b. MEASUREMENTS: THE HEIGHT AND/OR WIDTH OF TREES SHALL BE MEASURED FROM THE GROUND OR ACROSS THE NORMAL SPREAD OF BRANCHES WITH THE PLANTS IN THEIR NORMAL POSITION. THIS MEASUREMENT SHALL NOT INCLUDE THE IMMEDIATE TERMINAL GROWTH. PLANTS LARGER IN SIZE THAN THOSE SPECIFIED IN THE PLANT LIST MAY BE USED IF APPROVED BY THE OWNER. IF THE USE OF LARGER PLANTS IS APPROVED, THE BALL OF EARTH OR SPREAD OF ROOTS SHALL BE INCREASED IN PROPORTION TO THE SIZE OF THE PLANT.
- c. INSPECTION: PLANTS SHALL BE SUBJECT TO INSPECTION AND APPROVAL AT THE PLACE OF GROWTH, OR UPON DELIVERY TO THE SITE, AS DETERMINED BY THE OWNER. FOR QUALITY, SIZE, AND VARIETY; SUCH APPROVAL SHALL NOT IMPAIR THE RIGHT OF INSPECTION AND REJECTION AT THE SITE DURING PROGRESS OF THE WORK OR AFTER COMPLETION FOR SIZE AND CONDITION OF ROOT BALLS OR ROOTS, LATENT DEFECTS OR INJURIES. REJECTED PLANTS SHALL BE REMOVED IMMEDIATELY FROM THE SITE. NOTICE REQUESTING INSPECTION SHALL BE SUBMITTED IN WRITING BY THE CONTRACTOR AT LEAST ONE (1) WEEK PRIOR TO ANTICIPATED DATE.

E. SOIL MIXTURE

1. SOIL MIXTURE (PLANTING MEDIUM FOR PLANT PITS) SHALL CONSIST OF 50% COARSE SAND AND 50% FLORIDA PEAT, AS DESCRIBED BELOW.
2. SOIL FOR USE IN PREPARING SOIL MIXTURE FOR BACKFILLING PLANT PITS SHALL BE FERTILE, FRIABLE, AND OF A LOAMY CHARACTER; REASONABLY FREE OF SUBSOIL, CLAY LUMPS, BRUSH WEEDS AND OTHER LITTER; FREE OF ROOTS, STUMPS, STONES LARGER THAN 2" IN ANY DIRECTION, AND OTHER EXTRANEOUS OR TOXIC MATTER HARMFUL TO PLANT GROWTH. IT SHALL HAVE A PH BETWEEN 5.5 AND 7.0 - SUBMIT SAMPLE AND PH TESTING RESULTS FOR APPROVAL.
3. SAND SHALL BE COARSE, CLEAN, WELL-DRAINING, NATIVE SAND. CONTRACTOR SHALL SUBMIT RESULTS OF SOIL TEST FOR THE SOIL AND SAND PROPOSED FOR USE UNDER THIS CONTRACT FOR APPROVAL BY THE OWNER.
4. CONTRACTOR TO SUBMIT SAMPLES OF SOIL MIXTURE FOR OWNER'S REPRESENTATIVE APPROVAL PRIOR TO PLANT INSTALLATION OPERATIONS COMMENCE.
5. CONTRACTOR SHALL PROVIDE PH TEST RESULT FOR ALL MIX COMPONENTS.
6. CONTRACTOR SHALL PROVIDE PENETROMETER ON-SITE AT ALL TIMES FOR COMPACTION INSPECTION AT THE DISCRETION OF THE LANDSCAPE ARCHITECT.
7. PENETROMETER CRITERIA / SPECIFICATION SHALL RANGE FROM APPROX. 75 PSI TO LESS THAN 300 PSI OR AS DETERMINE BY LANDSCAPE ARCHITECT.
8. SOIL SHALL BE SUPPLIED BY ATLAS PEAT & SOIL INC. 9621 STATE RD, BOYNTON BEACH, FLORIDA 33472. PHONE: 561-734-7300 OR APPROVED EQUAL.
9. FINAL MIX SHALL BE TESTED TO HAVE A SATURATED WEIGHT OF NO MORE THAN 110 POUNDER PER CUBIC FOOT WHEN COMPACTED TO 85% STANDARDS PROCTOR.

F. WATER

1. WATER NECESSARY FOR PLANTING AND MAINTENANCE SHALL BE OF SATISFACTORY QUALITY TO SUSTAIN AN ADEQUATE PLANT GROWTH AND SHALL NOT CONTAIN HARMFUL, NATURAL OR MAN-MADE ELEMENTS DETRIMENTAL TO PLANTS. WATER MEETING THE ABOVE STANDARD SHALL BE OBTAINED ON THE SITE FROM THE OWNER, IF AVAILABLE, AND THE CONTRACTOR SHALL BE RESPONSIBLE TO MAKE ARRANGEMENTS FOR ITS USE BY HIS TANKS, HOSES, SPRINKLERS, ETC.. IF SUCH WATER IS NOT AVAILABLE AT THE SITE, THE CONTRACTOR SHALL PROVIDE SATISFACTORY WATER FROM SOURCES OFF THE SITE AT NO ADDITIONAL COST TO THE OWNER.
2. CONTRACTOR SHALL INSURE ALL PLANT MATERIAL RECEIVES APPROPRIATE WATER THROUGHOUT THE GUARANTEE PERIOD SO PLANT MATERIAL THRIVES AND ESTABLISHES READILY.
3. CONTRACTOR SHALL SUBMIT A WATERING SCHEDULE FOR WRITTEN APPROVAL BY THE CLIENT.

*WATERING/IRRIGATION RESTRICTIONS MAY APPLY - REFER TO PROPERTY'S JURISDICTIONAL AUTHORITY.

G. FERTILIZER

1. CONTRACTOR SHALL PROVIDE FERTILIZER APPLICATION SCHEDULE TO OWNER, AS APPLICABLE TO SOIL TYPE, PLANT INSTALLATION TYPE, AND SITE'S PROPOSED USE. SUGGESTED FERTILIZER TYPES SHALL BE ORGANIC OR OTHERWISE NATURALLY-DERIVED.
- *FERTILIZER RESTRICTIONS MAY APPLY - REFER TO PROPERTY'S JURISDICTIONAL AUTHORITY.

H. MULCH

1. MULCH MATERIAL SHALL BE MOISTENED AT THE TIME OF APPLICATION TO PREVENT WIND DISPLACEMENT, AND APPLIED AT A MINIMUM DEPTH OF 3 INCHES. CLEAR MULCH FROM EACH PLANT'S CROWN (BASE). TYPE OF MATERIAL: "FLORIMULCH" OR SHREDDED, STERILE EUCALYPTUS MULCH.

I. DIGGING AND HANDLING

1. PROTECT ROOTS OR ROOT BALLS OF PLANTS AT ALL TIMES FROM SUN, DRYING WINDS, WATER AND FREEZING, AS NECESSARY UNTIL PLANTING. PLANT MATERIALS SHALL BE ADEQUATELY PACKED TO PREVENT DAMAGE DURING TRANSIT. TREES TRANSPORTED MORE THAN TEN (10) MILES OR WHICH ARE NOT PLANTED WITHIN THREE (3) DAYS OF DELIVERY TO SITE SHALL BE SPRAYED WITH AN ANTITRANSPIRANT PRODUCT ("WILTPRUF" OR EQUAL) TO MINIMIZE TRANSPIRATIONAL WATER LOSS.
2. BALLED AND BURLAPPED PLANTS (B&B) SHALL BE DUG WITH FIRM, NATURAL BALLS OF SOIL OF SUFFICIENT SIZE TO ENCOMPASS THE FIBROUS AND FEEDING ROOTS OF THE PLANTS. NO PLANTS MOVED WITH A ROOT BALL SHALL BE PLANTED IF THE BALL IS CRACKED OR BROKEN. PLANTS BALLED AND BURLAPPED OR CONTAINER GROWN SHALL NOT BE HANDLED BY STEMS.
3. PLANTS MARKED "BR" IN THE PLANT LIST SHALL BE DUG WITH BARE ROOTS, COMPLYING WITH FLORIDA GRADES AND STANDARDS FOR NURSERY PLANTS, CURRENT EDITION. CARE SHALL BE EXERCISED THAT THE ROOTS DO NOT DRY OUT DURING TRANSPORTATION AND PRIOR TO PLANTING.
4. PROTECTION OF PALMS (IF APPLICABLE): ONLY A MINIMUM OF FRONDS SHALL BE REMOVED FROM THE CROWN OF THE PALM TREES TO FACILITATE MOVING AND HANDLING. CLEAR TRUNK (CT) SHALL BE AS SPECIFIED AFTER THE MINIMUM OF FRONDS HAVE BEEN REMOVED. ALL PALMS SHALL BE BRACED PER PALM PLANTING DETAIL.
5. EXCAVATION OF TREE PITS SHALL BE PERFORMED USING EXTREME CARE TO AVOID DAMAGE TO SURFACE AND SUBSURFACE ELEMENTS SUCH AS UTILITIES OR HARDSCAPE ELEMENTS, FOOTERS AND PREPARED SUB-BASES.

J. CONTAINER GROWN STOCK

1. ALL CONTAINER GROWN MATERIAL SHALL BE HEALTHY, VIGOROUS, WELL-ROOTED PLANTS ESTABLISHED IN THE CONTAINER IN WHICH THEY ARE SOLD. THE PLANTS SHALL HAVE TOPS WHICH ARE OF GOOD QUALITY AND ARE IN A HEALTHY GROWING CONDITION, FLORIDA #1 OR BETTER.
2. AN ESTABLISHED CONTAINER GROWN PLANT SHALL BE TRANSPLANTED INTO A CONTAINER AND GROWN IN THAT CONTAINER SUFFICIENTLY LONG FOR THE NEW FIBROUS ROOTS TO HAVE DEVELOPED SO THAT THE ROOT MASS WILL RETAIN ITS SHAPE AND HOLD TOGETHER WHEN REMOVED FROM THE CONTAINER. CONTAINER GROWN STOCK SHALL NOT BE HANDLED BY THEIR STEMS.
3. PLANT ROOTS BOUND IN CONTAINERS ARE NOT ACCEPTABLE.
4. SUBSTITUTION OF NON-CONTAINER GROWN MATERIAL FOR MATERIAL EXPLICITLY SPECIFIED TO BE CONTAINER GROWN WILL NOT BE PERMITTED WITHOUT WRITTEN APPROVAL IS OBTAINED FROM THE OWNER OR OWNER'S REPRESENTATIVE.

K. COLLECTED STOCK

1. WHEN THE USE OF COLLECTED STOCK IS PERMITTED AS INDICATED BY THE OWNER OR OWNER'S REPRESENTATIVE, THE MINIMUM SIZES OF ROOTBALLS SHALL BE EQUAL TO THAT SPECIFIED FOR THE NEXT LARGER SIZE OF NURSERY GROWN STOCK OF THE SAME VARIETY.

L. NATIVE STOCK

1. PLANTS COLLECTED FROM WILD OR NATIVE STANDS SHALL BE CONSIDERED NURSERY GROWN WHEN THEY HAVE BEEN SUCCESSFULLY RE-ESTABLISHED IN A NURSERY ROW AND GROWN UNDER REGULAR NURSERY CULTURAL PRACTICES FOR A MINIMUM OF TWO (2) GROWING SEASONS AND HAVE ATTAINED ADEQUATE ROOT AND TOP GROWTH TO INDICATE FULL RECOVERY FROM TRANSPLANTING INTO THE NURSERY ROW.

M. MATERIALS LIST

1. QUANTITIES NECESSARY TO COMPLETE THE WORK ON THE DRAWINGS SHALL BE FURNISHED BY THE CONTRACTOR. QUANTITY ESTIMATES HAVE BEEN MADE CAREFULLY, BUT THE LANDSCAPE ARCHITECT OR OWNER ASSUMES NO LIABILITY FOR OMISSIONS OR ERRORS. SHOULD A DISCREPANCY OCCUR BETWEEN THE PLANS AND THE PLANT LIST QUANTITY, THE LANDSCAPE ARCHITECT SHALL BE NOTIFIED FOR CLARIFICATION PRIOR TO BIDDING OR INSTALLATION. ALL DIMENSIONS AND/OR SIZES SPECIFIED SHALL BE THE MINIMUM ACCEPTABLE SIZE.

N. FINE GRADING

1. FINE GRADING UNDER THIS CONTRACT SHALL CONSIST OF FINAL FINISHED GRADING OF LAWN AND PLANTING AREAS THAT HAVE BEEN ROUGH GRADED BY OTHERS. BERMING AS SHOWN ON THE DRAWINGS SHALL BE THE RESPONSIBILITY OF THE CONTRACTOR, UNLESS OTHERWISE NOTED.
2. THE CONTRACTOR SHALL FINE GRADE THE LAWN AND PLANTING AREAS TO BRING THE ROUGH GRADE UP TO FINAL FINISHED GRADE ALLOWING FOR THICKNESS OF SOD AND/OR MULCH DEPTH. THIS CONTRACTOR SHALL FINE GRADE BY HAND AND/OR WITH ALL EQUIPMENT NECESSARY INCLUDING A GRADING TRACTOR WITH FRONT-END LOADER FOR TRANSPORTING SOIL WITHIN THE SITE.
3. ALL PLANTING AREAS SHALL BE GRADED AND MAINTAINED FOR POSITIVE DRAINAGE TO SURFACE/SUBSURFACE STORM DRAIN SYSTEMS. AREAS ADJACENT TO BUILDINGS SHALL SLOPE AWAY FROM THE BUILDINGS. REFER TO CIVIL ENGINEER'S PLANS FOR FINAL GRADES.

O. PLANTING PROCEDURES

1. CLEANING UP BEFORE COMMENCING WORK: THE CONTRACTOR SHALL CLEAN WORK AND SURROUNDING AREAS OF ALL RUBBISH OR OBJECTIONABLE MATTER. ALL MORTAR, CEMENT, AND TOXIC MATERIAL SHALL BE REMOVED FROM THE SURFACE OF ALL PLANT BEDS. THESE MATERIALS SHALL NOT BE MIXED WITH THE SOIL. SHOULD THE CONTRACTOR FIND SUCH SOIL CONDITIONS BENEATH THE SOIL WHICH WILL IN ANY WAY ADVERSELY AFFECT THE PLANT GROWTH, HE SHALL IMMEDIATELY CALL IT TO THE ATTENTION OF THE OWNER'S REPRESENTATIVE. FAILURE TO DO SO BEFORE PLANTING SHALL MAKE THE CORRECTIVE MEASURES THE RESPONSIBILITY OF THE CONTRACTOR.
2. VERIFY LOCATIONS OF ALL UTILITIES, CONDUITS, SUPPLY LINES AND CABLES, INCLUDING BUT NOT LIMITED TO: ELECTRIC, GAS (LINES AND TANKS), WATER, SANITARY SEWER, STORMWATER SYSTEMS, CABLE, AND TELEPHONE. PROPERLY MAINTAIN AND PROTECT EXISTING UTILITIES. CALL NATIONAL ONE CALL - 811 - TO LOCATE UTILITIES.
3. SUBGRADE EXCAVATION: CONTRACTOR IS RESPONSIBLE TO REMOVE ALL EXISTING AND IMPORTED LIMEROCK AND LIMEROCK SUB-BASE FROM ALL LANDSCAPE PLANTING AREAS TO A MINIMUM DEPTH OF 36". CONTRACTOR IS RESPONSIBLE TO BACKFILL THESE PLANTING AREAS TO ROUGH FINISHED GRADE WITH CLEAN TOPSOIL FROM AN ON-SITE SOURCE OR AN IMPORTED SOURCE. IF LIMEROCK OR OTHER ADVERSE CONDITIONS OCCUR IN PLANTED AREAS AFTER 36" DEEP EXCAVATION BY THE CONTRACTOR, AND ADEQUATE PERCOLATION CAN NOT BE ACHIEVED, CONTRACTOR SHALL UTILIZE PLANTING DETAIL THAT ADDRESSES POOR DRAINAGE.
4. FURNISH NURSERY'S CERTIFICATE OF COMPLIANCE WITH ALL REQUIREMENTS AS HEREIN SPECIFIED AND REQUIRED. INSPECT AND SELECT PLANT MATERIALS BEFORE PLANTS ARE DUG AT NURSERY OR GROWING SITE.
5. GENERAL COMPLY WITH APPLICABLE FEDERAL, STATE, COUNTY, AND LOCAL REGULATIONS GOVERNING LANDSCAPE MATERIALS AND WORK. CONFORM TO ACCEPTED HORTICULTURAL PRACTICES AS USED IN THE TRADE. UPON ARRIVAL AT THE SITE, PLANTS SHALL BE THOROUGHLY WATERED AND PROPERLY MAINTAINED UNTIL PLANTED. PLANTS STORED ON-SITE SHALL NOT REMAIN UNPLANTED FOR A PERIOD EXCEEDING TWENTY-FOUR (24) HOURS. AT ALL TIMES, METHODS CUSTOMARY IN GOOD HORTICULTURAL PRACTICES SHALL BE EXERCISED.
6. THE WORK SHALL BE COORDINATED WITH OTHER TRADES TO PREVENT CONFLICTS. COORDINATE PLANTING WITH IRRIGATION WORK TO ASSURE AVAILABILITY OF WATER AND PROPER LOCATION OF IRRIGATION APPURTENANCES AND PLANTS.
7. ALL PLANTING PITS SHALL BE EXCAVATED TO SIZE AND DEPTH IN ACCORDANCE WITH THE USA STANDARD FOR NURSERY STOCK 260.1, UNLESS SHOWN OTHERWISE ON THE DRAWINGS, AND BACKFILLED WITH THE PREPARED PLANTING SOIL MIXTURE AS SPECIFIED IN SECTION E. TEST ALL TREE PITS WITH WATER BEFORE PLANTING TO ASSURE PROPER DRAINAGE PERCOLATION IS AVAILABLE. NO ALLOWANCE WILL BE MADE FOR LOST PLANTS DUE TO IMPROPER PERCOLATION. IF POOR PERCOLATION EXISTS, UTILIZE "POOR DRAINAGE CONDITION" PLANTING DETAIL. TREES SHALL BE SET PLUMB AND HELD IN POSITION UNTIL THE PLANTING MIXTURE HAS BEEN FLUSHED INTO PLACE WITH A SLOW, FULL HOSE STREAM. ALL PLANTING SHALL BE PERFORMED BY PERSONNEL FAMILIAR WITH PLANTING PROCEDURES AND UNDER THE SUPERVISION OF A QUALIFIED LANDSCAPE FOREMAN. PROPER "JETTING IN" SHALL BE ASSURED TO ELIMINATE AIR POCKETS AROUND THE ROOTS. "JET STICK" OR EQUAL IS RECOMMENDED.
8. TAKE ALL NECESSARY PRECAUTIONS TO AVOID DAMAGE TO BUILDINGS AND BUILDING STRUCTURES WHILE INSTALLING TREES.
9. SOIL MIXTURE SHALL BE AS SPECIFIED IN SECTION E OF THESE SPECIFICATIONS.
10. TREES AND SHRUBS SHALL BE SET STRAIGHT AT AN ELEVATION THAT, AFTER SETTLEMENT, THE PLANT CROWN WILL STAND ONE (1) TO TWO (2) INCHES ABOVE GRADE. EACH PLANT SHALL BE SET IN THE CENTER OF THE PIT. PLANTING SOIL MIXTURE SHALL BE BACKFILLED, THOROUGHLY TAMPED AROUND THE BALL, AND SETTLED BY WATER (AFTER TAMPING).
11. AMEND PINE AND OAK PLANT PITS WITH ECTOMYCORRHIZAL SOIL APPLICATION PER MANUFACTURER'S RECOMMENDATION. ALL OTHER PLANT PITS SHALL BE AMENDED WITH ENDOMYCORRHIZAL SOIL APPLICATION PER MANUFACTURER'S RECOMMENDATION. PROVIDE PRODUCT INFORMATION SUBMITTAL PRIOR TO INOCULATION.
12. FILL HOLE WITH SOIL MIXTURE, MAKING CERTAIN ALL SOIL IS SATURATED. TO DO THIS, FILL HOLE WITH WATER AND ALLOW TO SOAK MINIMUM TWENTY (20) MINUTES, STIRRING IF NECESSARY TO GET SOIL THOROUGHLY WET. PACK LIGHTLY WITH FEET. ADD MORE WET SOIL MIXTURE. DO NOT COVER TOP OF BALL WITH SOIL MIXTURE, ONLY WITH MULCH. ALL BURLAP, ROPE, WIRES, BASKETS, ETC., SHALL BE REMOVED FROM THE SIDES AND TOPS OF BALLS, BUT NO BURLAP SHALL BE PULLED FROM UNDERNEATH.
13. PRUNING: TREES SHALL BE PRUNED, AT THE DIRECTION OF THE OWNER OR OWNER'S REPRESENTATIVE, TO PRESERVE THE NATURAL CHARACTER OF THE PLANT. ALL SOFT WOOD OR SUCKER GROWTH AND ALL BROKEN OR BADLY DAMAGED BRANCHES SHALL BE REMOVED WITH A CLEAN CUT. ALL PRUNING TO BE PERFORMED BY LICENSED ARBORIST, IN ACCORDANCE WITH ANSI A-300.
14. SHRUBS AND GROUND COVER PLANTS SHALL BE EVENLY SPACED IN ACCORDANCE WITH THE DRAWINGS AND AS INDICATED ON THE PLANT LIST. CULTIVATE ALL PLANTING AREAS TO A MINIMUM DEPTH OF 6". REMOVE AND DISPOSE ALL DEBRIS. MIX TOP 4" TO ACHIEVE SOIL MIXTURE AS SPECIFIED IN SECTION E. THOROUGHLY WATER ALL PLANTS AFTER INSTALLATION.
15. TREE GUYING AND BRACING SHALL BE INSTALLED BY THE CONTRACTOR IN ACCORDANCE WITH THE PLANS TO INSURE STABILITY AND MAINTAIN TREES IN AN UPRIGHT POSITION. IF THE CONTRACTOR AND OWNER DECIDE TO WAIVE THE TREE GUYING AND BRACING, THE OWNER SHALL NOTIFY THE LANDSCAPE ARCHITECT IN WRITING AND AGREE TO INDEMNIFY AND HOLD HARMLESS THE LANDSCAPE ARCHITECT IN THE EVENT UNSUPPORTED TREES PLANTED UNDER THIS CONTRACT FALL AND DAMAGE PERSON OR PROPERTY.
16. MULCHING: PROVIDE A THREE INCH (MINIMUM) LAYER OF SPECIFIED MULCH OVER THE ENTIRE AREA OF EACH SHRUB BED, GROUND COVER, VINE BED, AND TREE PIT PLANTED UNDER THIS CONTRACT.
17. HERBICIDE WEED CONTROL: ALL PLANT BEDS SHALL BE KEPT FREE OF NOXIOUS WEEDS UNTIL FINAL ACCEPTANCE OF WORK. IF DIRECTED BY THE OWNER, "ROUND-UP" SHALL BE APPLIED FOR WEED CONTROL BY QUALIFIED PERSONNEL TO ALL PLANTING AREAS IN SPOT APPLICATIONS PER MANUFACTURER'S PRECAUTIONS AND SPECIFICATIONS. PRIOR TO FINAL INSPECTION, TREAT ALL PLANTING BEDS WITH AN APPROVED PRE-EMERGENT HERBICIDE AT AN APPLICATION RATE RECOMMENDED BY THE MANUFACTURER. (AS ALLOWED BY JURISDICTIONAL AUTHORITY)

P. LAWN SODDING

1. THE WORK CONSISTS OF LAWN BED PREPARATION, SOIL PREPARATION, AND SODDING COMPLETE, IN STRICT ACCORDANCE WITH THE SPECIFICATIONS AND THE APPLICABLE DRAWINGS TO PRODUCE A TURF GRASS LAWN ACCEPTABLE TO THE OWNER.
2. LAWN BED PREPARATION: ALL AREAS THAT ARE TO BE SODDED SHALL BE CLEARED OF ANY ROUGH GRASS, WEEDS, AND DEBRIS, AND THE GROUND BROUGHT TO AN EVEN GRADE. THE ENTIRE SURFACE SHALL BE ROLLED WITH A ROLLER WEIGHING NOT MORE THAN ONE-HUNDRED (100) POUNDS PER FOOT OF WIDTH. DURING THE ROLLING, ALL DEPRESSIONS CAUSED BY SETTLEMENT SHALL BE FILLED WITH ADDITIONAL SOIL, AND THE SURFACE SHALL BE REGRADED AND ROLLED UNTIL PRESENTING A SMOOTH AND EVEN FINISH TO THE REQUIRED GRADE.
3. SOIL PREPARATION: PREPARE LOOSE BED FOUR (4) INCHES DEEP. HAND RAKE UNTIL ALL BUMPS AND DEPRESSIONS ARE REMOVED. WET PREPARED AREA THOROUGHLY.
4. SODDING
 - a. THE CONTRACTOR SHALL SOD ALL AREAS THAT ARE NOT PAVED OR PLANTED AS DESIGNATED ON THE DRAWINGS WITHIN THE CONTRACT LIMITS, UNLESS SPECIFICALLY NOTED OTHERWISE.
 - b. THE SOD SHALL BE CERTIFIED TO MEET FLORIDA STATE PLANT BOARD SPECIFICATIONS, ABSOLUTELY TRUE TO VARIETAL TYPE, AND FREE FROM WEEDS, FUNGUS, INSECTS AND DISEASE OF ANY KIND.
 - c. SOD PANELS SHALL BE LAID TIGHTLY TOGETHER SO AS TO MAKE A SOLID SODDED LAWN AREA. SOD SHALL BE LAID UNIFORMLY AGAINST THE EDGES OF ALL CURBS AND OTHER HARDSCAPE ELEMENTS, PAVED AND PLANTED AREAS ADJACENT TO BUILDINGS, A 24 INCH STONE MULCH STRIP SHALL BE PROVIDED - REFER TO DETAILS. IMMEDIATELY FOLLOWING SOD LAYING, THE LAWN AREAS SHALL BE ROLLED WITH A LAWN ROLLER CUSTOMARILY USED FOR SUCH PURPOSES, AND THEN THOROUGHLY IRRIGATED. IF, IN THE OPINION OF THE OWNER, TOP-DRESSING IS NECESSARY AFTER ROLLING TO FILL THE VOIDS BETWEEN THE SOD PANELS AND TO EVEN OUT INCONSISTENCIES IN THE SOD, CLEAN SAND, AS APPROVED BY THE OWNER'S REPRESENTATIVE, SHALL BE UNIFORMLY SPREAD OVER THE ENTIRE SURFACE OF THE SOD AND THOROUGHLY WATERED IN. FERTILIZE INSTALLED SOD AS ALLOWED BY PROPERTY'S JURISDICTIONAL AUTHORITY.
5. DURING DELIVERY, PRIOR TO, AND DURING THE PLANTING OF THE LAWN AREAS, THE SOD PANELS SHALL AT ALL TIMES BE PROTECTED FROM EXCESSIVE DRYING AND UNNECESSARY EXPOSURE OF THE ROOTS TO THE SUN. ALL SOD SHALL BE STACKED SO AS NOT TO BE DAMAGED BY SWEATING OR EXCESSIVE HEAT AND MOISTURE.
6. LAWN MAINTENANCE:
 - a. WITHIN THE CONTRACT LIMITS, THE CONTRACTOR SHALL PRODUCE A DENSE, WELL ESTABLISHED LAWN. THE CONTRACTOR SHALL BE RESPONSIBLE FOR THE REPAIR AND RE-SODDING OF ALL ERODED, SUNKEN OR BARE SPOTS (LARGER THAN 12"x12") UNTIL CERTIFICATION OF ACCEPTABILITY BY THE OWNER'S REPRESENTATIVE. REPAIRED SODDING SHALL BE ACCOMPLISHED AS IN THE ORIGINAL WORK (INCLUDING REGRAVING IF NECESSARY).
 - b. CONTRACTOR RESPONSIBLE FOR ESTABLISHING AND MAINTAINING SOD/LAWN UNTIL ACCEPTANCE BY THE OWNER'S REPRESENTATIVE. PRIOR TO AND UPON ACCEPTANCE, CONTRACTOR TO PROVIDE WATERING/IRRIGATION SCHEDULE TO OWNER. OBSERVE ALL APPLICABLE WATERING RESTRICTIONS AS SET FORTH BY THE PROPERTY'S JURISDICTIONAL AUTHORITY.

Q. CLEANUP

1. UPON COMPLETION OF ALL PLANTING WORK AND BEFORE FINAL ACCEPTANCE, THE CONTRACTOR SHALL REMOVE ALL MATERIAL, EQUIPMENT, AND DEBRIS RESULTING FROM HIS WORK. ALL PAVED AREAS SHALL BE BROOM-CLEANED AND THE SITE LEFT IN A NEAT AND ACCEPTABLE CONDITION AS APPROVED BY THE OWNER'S AUTHORIZED REPRESENTATIVE.

R. PLANT MATERIAL MAINTENANCE

1. ALL PLANTS AND PLANTING INCLUDED UNDER THIS CONTRACT SHALL BE MAINTAINED BY WATERING, CULTIVATING, SPRAYING, AND ALL OTHER OPERATIONS (SUCH AS RE-STAKING OR REPAIRING GUY SUPPORTS) NECESSARY TO INSURE A HEALTHY PLANT CONDITION BY THE CONTRACTOR UNTIL CERTIFICATION OF ACCEPTABILITY BY THE OWNER'S REPRESENTATIVE. MAINTENANCE AFTER THE CERTIFICATION OF ACCEPTABILITY SHALL BE IN ACCORDANCE WITH THE SPECIFICATIONS IN THIS SECTION. CONTRACTORS ARE REQUESTED TO PROVIDE A BID ESTIMATE TO COVER LANDSCAPE AND IRRIGATION MAINTENANCE FOR A PERIOD OF 90 CALENDAR DAYS COMMENCING AFTER ACCEPTANCE.

S. MAINTENANCE (ALTERNATE BID ITEM)

1. CONTRACTORS ARE REQUESTED TO PROVIDE A BID ESTIMATE FOR MAINTENANCE FOLLOWING THE INITIAL 90-DAY MAINTENANCE PERIOD ON A COST-PER-MONTH BASIS.

T. FINAL INSPECTION AND ACCEPTANCE OF WORK

1. FINAL INSPECTION AT THE END OF THE WARRANTY PERIOD SHALL BE ON PLANTING, CONSTRUCTION AND ALL OTHER INCIDENTAL WORK PERTAINING TO THIS CONTRACT. ANY REPLACEMENT AT THIS TIME SHALL BE SUBJECT TO THE SAME ONE (1) YEAR WARRANTY (OR AS SPECIFIED BY THE LANDSCAPE ARCHITECT OR OWNER IN WRITING) BEGINNING WITH THE TIME OF REPLACEMENT AND ENDING WITH THE SAME INSPECTION AND ACCEPTANCE HEREIN DESCRIBED.

U. WARRANTY

1. THE LIFE AND SATISFACTORY CONDITION OF ALL PLANT MATERIAL INSTALLED BY THE LANDSCAPE CONTRACTOR SHALL BE WARRANTED BY THE CONTRACTOR FOR A MINIMUM OF ONE (1) CALENDAR YEAR COMMENCING AT THE TIME OF CERTIFICATION OF ACCEPTABILITY BY THE OWNER'S REPRESENTATIVE.
2. REPLACEMENT: ANY PLANT NOT FOUND IN A HEALTHY GROWING CONDITION AT THE END OF THE WARRANTY PERIOD SHALL BE REMOVED FROM THE SITE AND REPLACED AS SOON AS WEATHER CONDITIONS PERMIT. ALL REPLACEMENTS SHALL BE PLANTS OF THE SAME KIND AND SIZE AS SPECIFIED IN THE PLANT LIST. THEY SHALL BE FURNISHED PLANTED AND MULCHED AS SPECIFIED UNDER "PLANTING", AT NO ADDITIONAL COST TO THE OWNER.
3. IN THE EVENT THE OWNER DOES NOT CONTRACT WITH THE CONTRACTOR FOR LANDSCAPE (AND IRRIGATION) MAINTENANCE, THE CONTRACTOR IS ENCOURAGED TO VISIT THE PROJECT SITE PERIODICALLY DURING THE ONE YEAR WARRANTY PERIOD TO EVALUATE MAINTENANCE PROCEDURES BEING PERFORMED BY THE OWNER, AND SHALL NOTIFY THE OWNER IN WRITING OF MAINTENANCE PROCEDURES OR CONDITIONS WHICH THREATEN VIGOROUS AND HEALTHY PLANT GROWTH. IT IS SUGGESTED SUCH SITE VISITS SHALL BE CONDUCTED A MINIMUM OF ONCE PER MONTH FOR A PERIOD OF TWELVE (12) MONTHS FROM THE DATE OF ACCEPTANCE.

No.	REVISIONS	DATE	BY



 © 2021 KIMLEY-HORN AND ASSOCIATES, INC.
 1615 S. CONGRESS AVE. SUITE 201,
 DELRAY BEACH, FL 33445
 PHONE: 561-330-2345 FAX: 561-863-8175
 WWW.KIMLEY-HORN.COM REGISTRY NO. 696

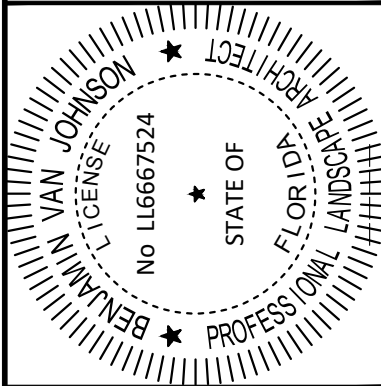

KHA PROJECT 046265028	DATE 10/19/2021
SCALE AS SHOWN	DESIGNED BY
CHECKED BY	DRAWN BY

LANDSCAPE SPECIFICATIONS
 PROJECT GLADES PREPARED FOR SEEFRIED INDUSTRIAL PROPERTIES, INC. CITY OF PORT ST. LUCIE, FLORIDA

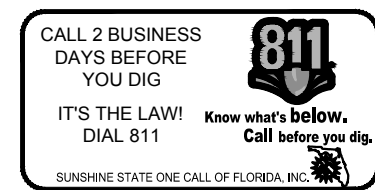

PSLUSD PROJECT NO. 11-869-07A
CITY OF PSL PROJECT NO. P21-251

THIS ITEM HAS BEEN DIGITALLY SIGNED AND SEALED BY BENJAMIN V. JOHNSON, P.L.A., ON THE DATE ADJACENT TO THE SEAL.

PRINTED COPIES OF THIS DOCUMENT ARE NOT CONSIDERED SIGNED AND SEALED AND THE SIGNATURE MUST BE VERIFIED ON ANY ELECTRONIC COPIES.

SHEET NUMBER
L-350

Plotted By: johnson, Ben Sheet: Set: Amazon Glades Cut-Off Road Layout: DETAILS January 18, 2022 08:23:54am K:\ORG-URGLAKELAND\amazon_glades_cut_off\landscape\CADD\plansheets\L-350_LANDSCAPE_SPECS_AND_DETAILS.dwg
 This document, together with the concepts and designs presented herein, is intended only for the specific purpose and client for which it was prepared. Reuse of and improper reliance on this document without written authorization and adaptation by Kimley-Horn and Associates, Inc. shall be without liability to Kimley-Horn and Associates, Inc.

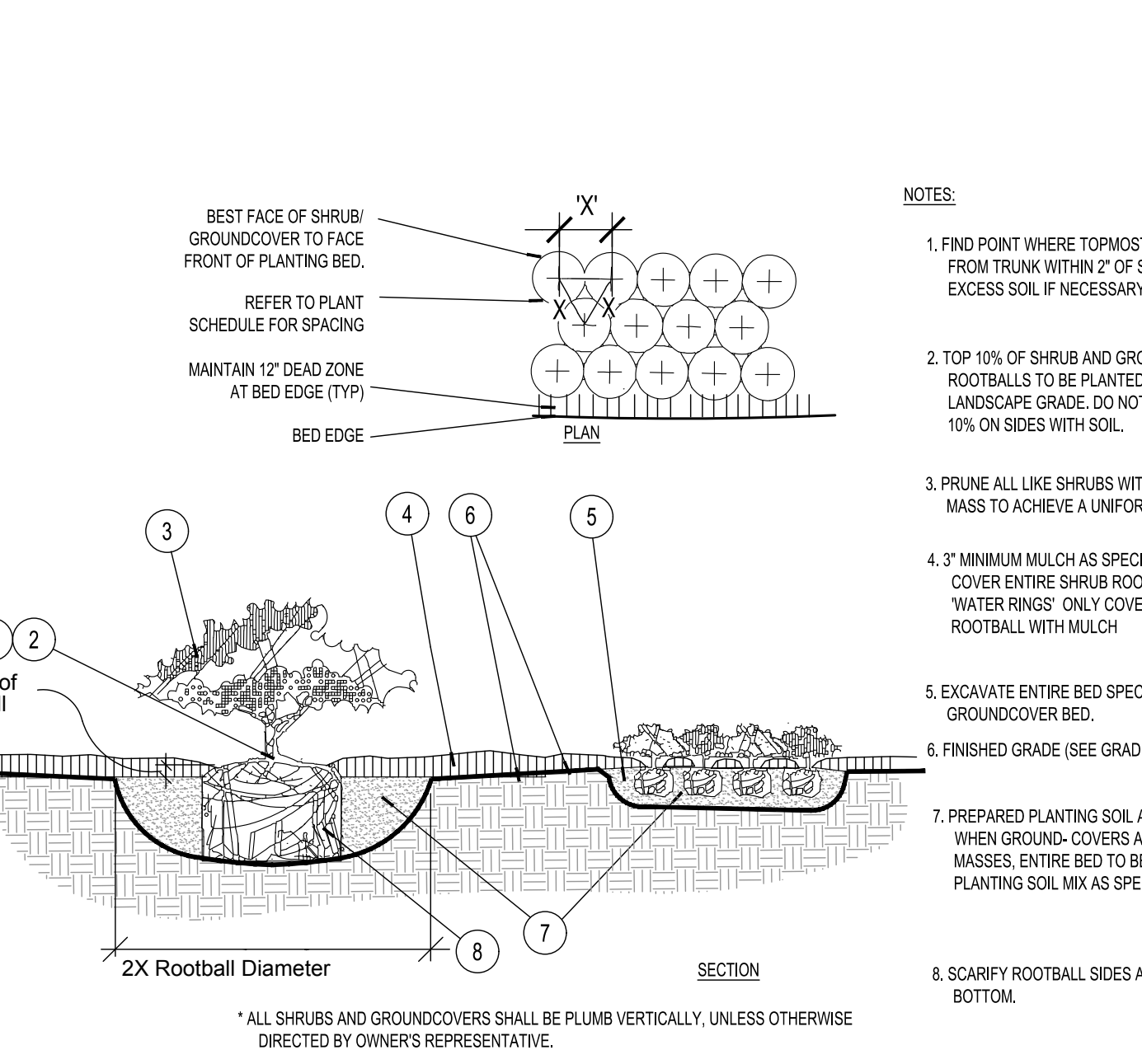
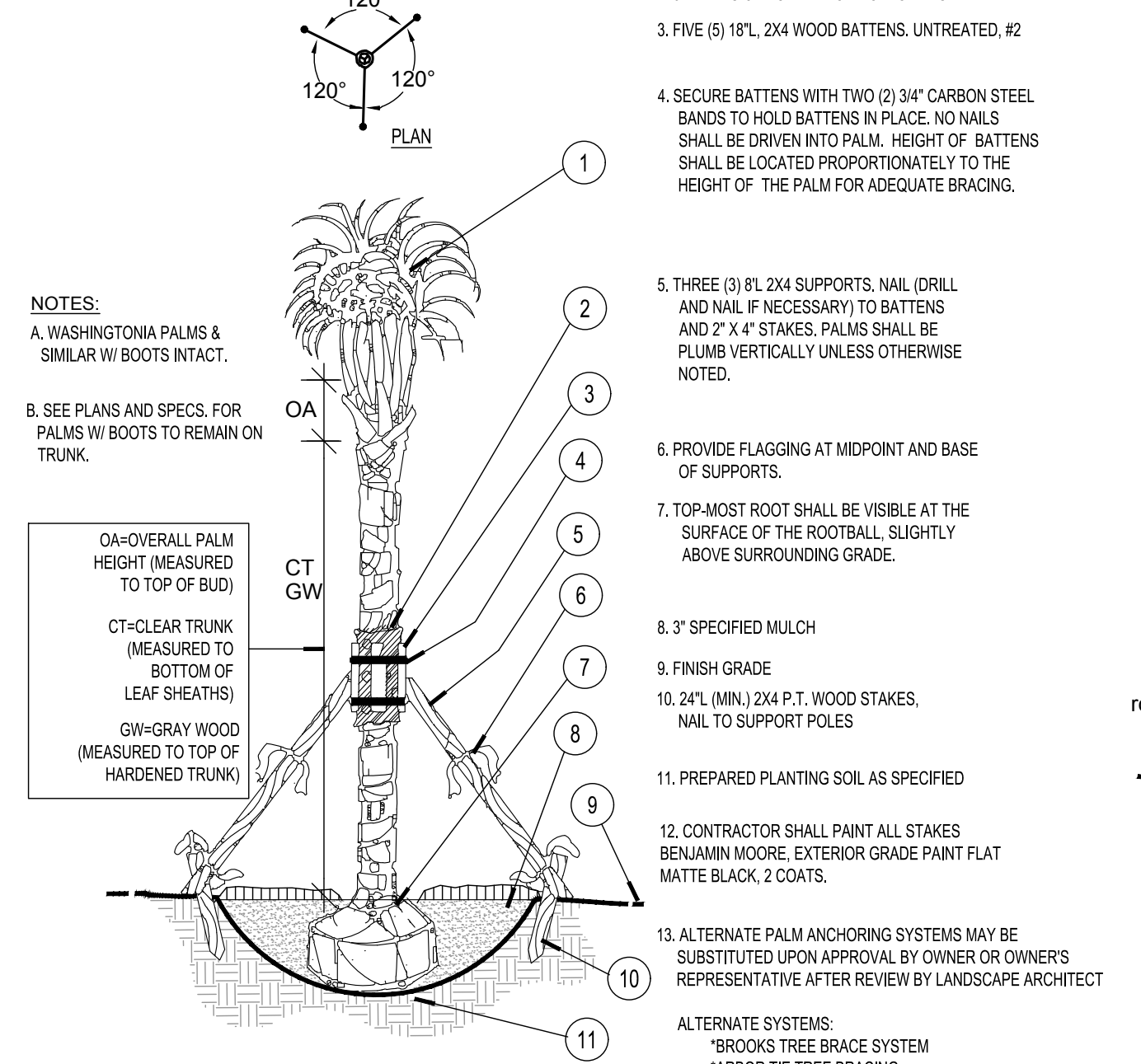
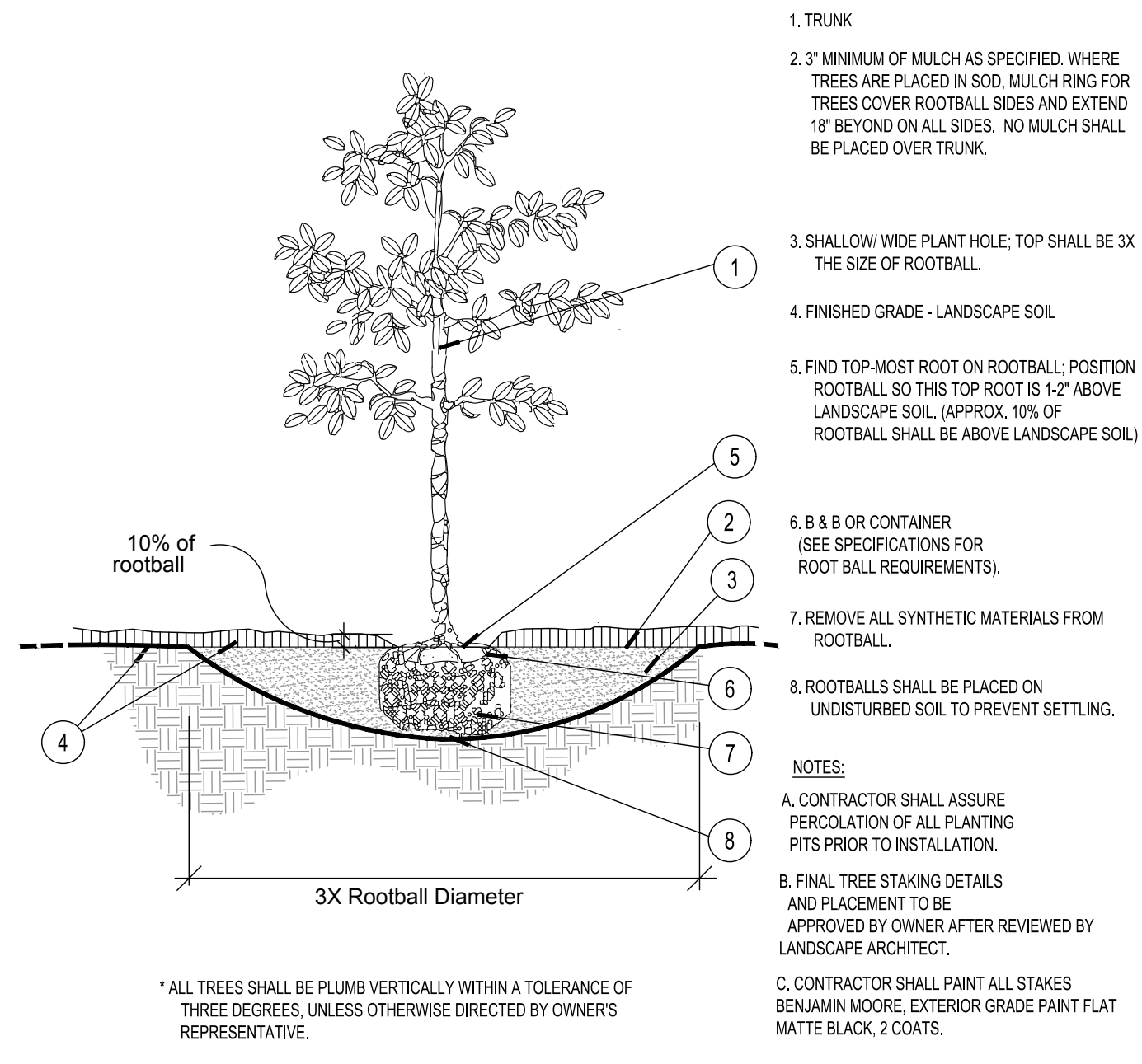

A Tree Planting
SECTION NTS

B Palm Planting and Staking
SECTION NTS

C Shrub / Groundcover Planting
SECTION NTS

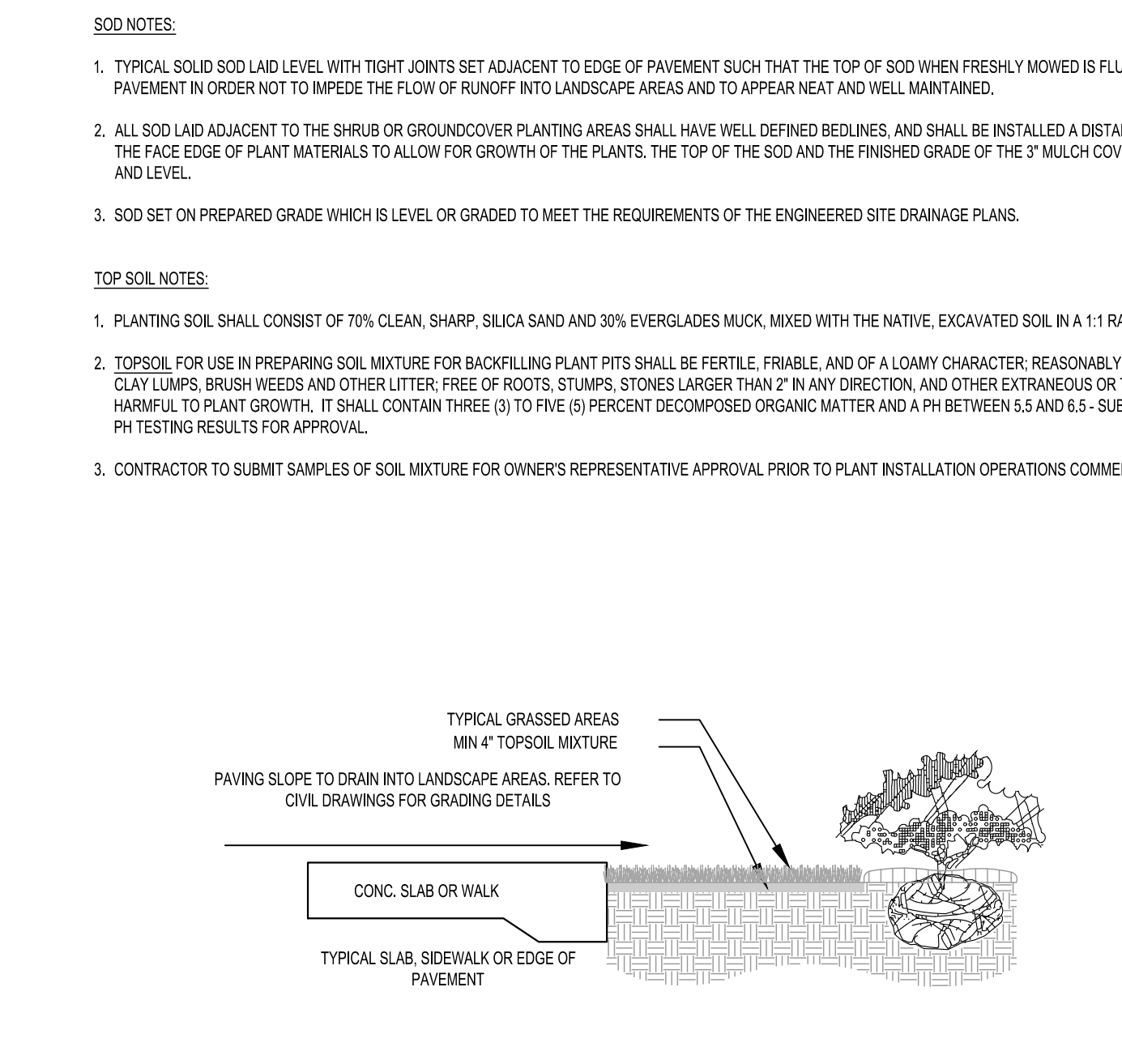
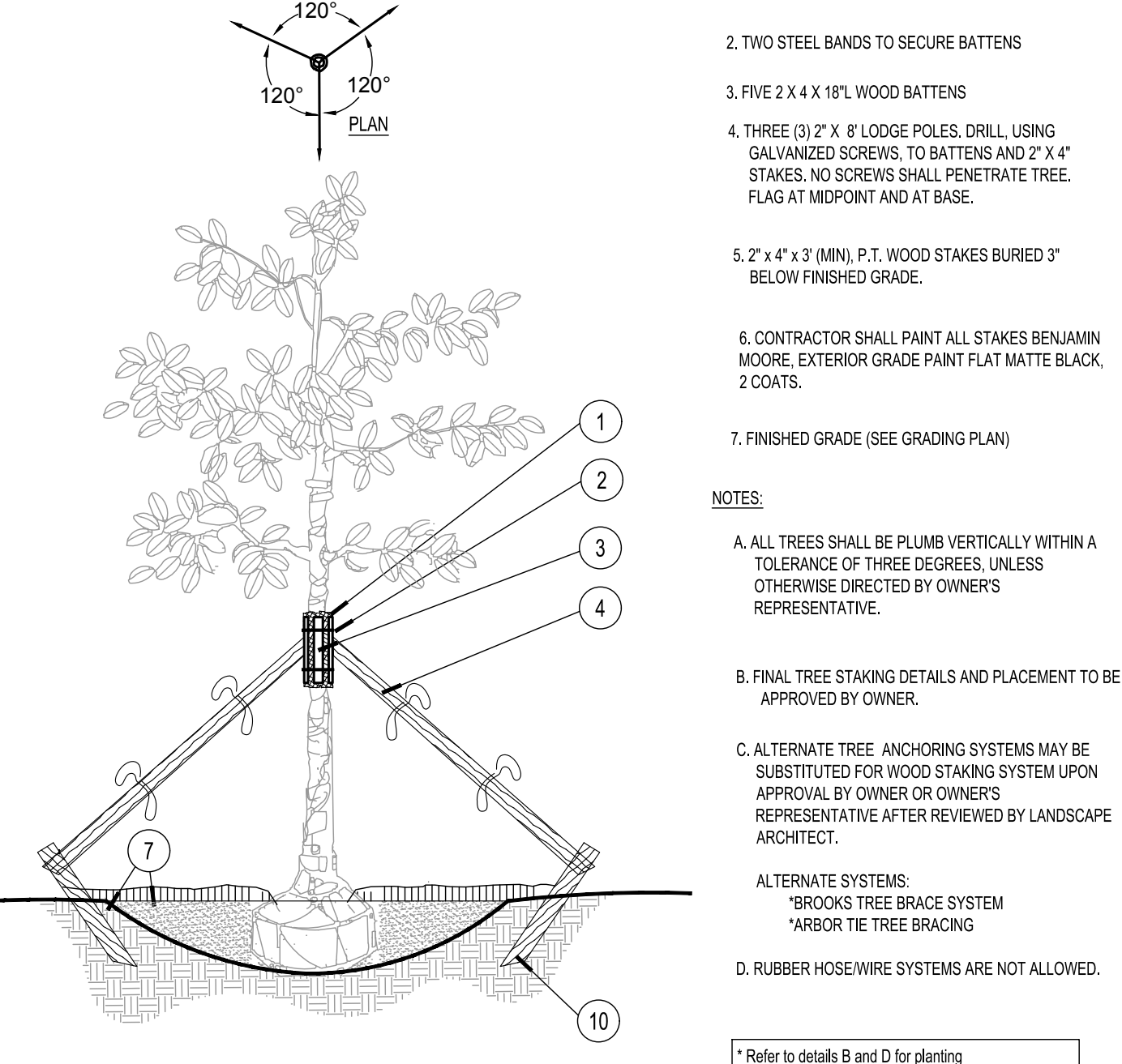
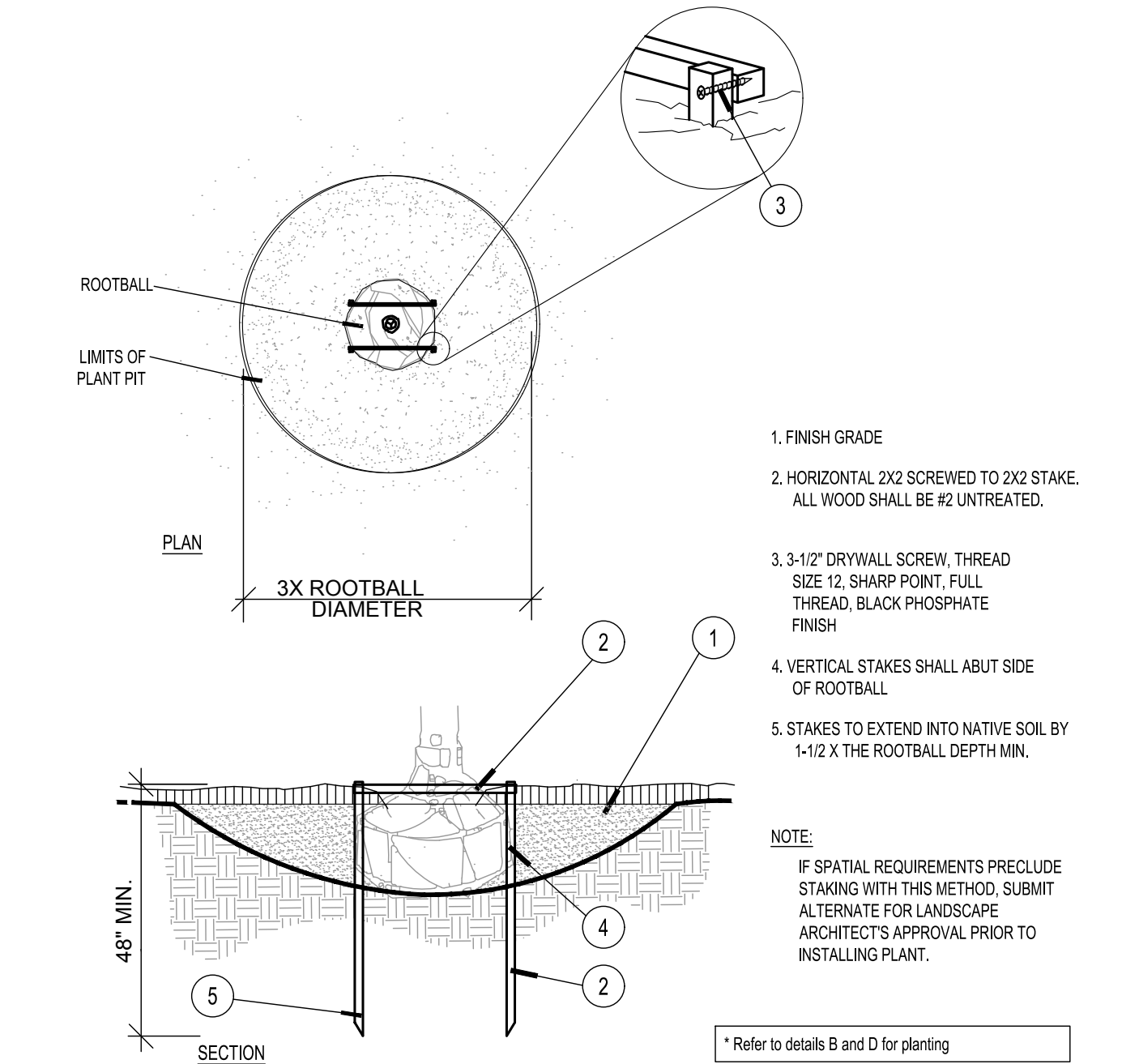

D Staking - up to 65 gal. or B&B to 3-1/2\"/>

E Large Tree Staking - 100 Gal + or B&B 4\"/>

F SOD
SECTION NTS

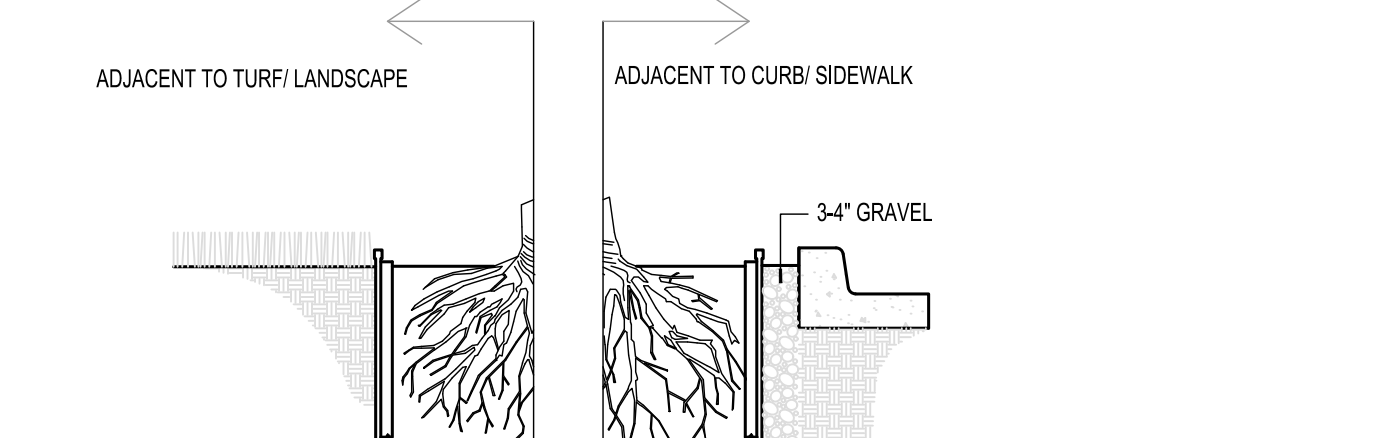
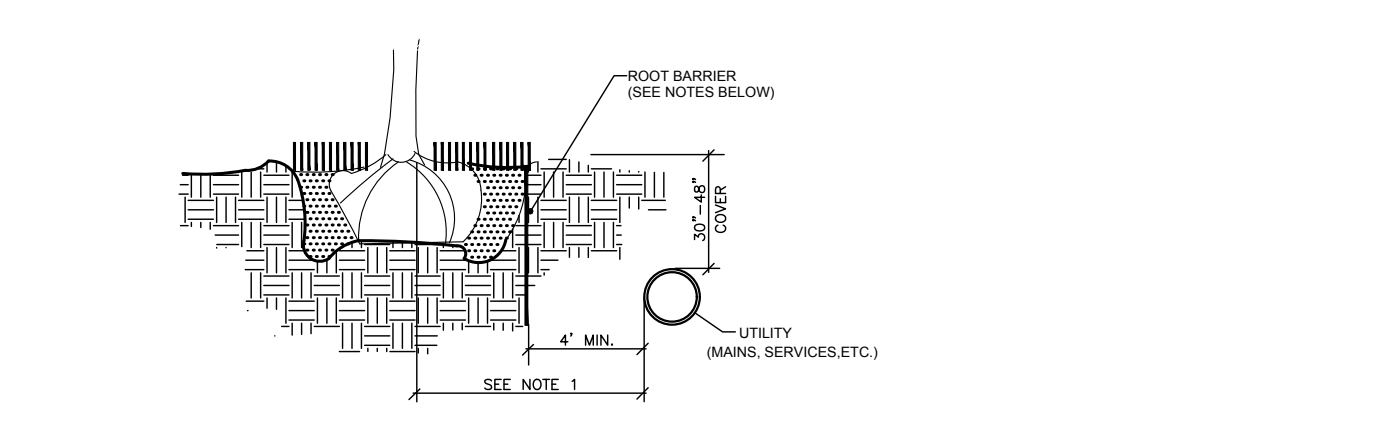

NOTES: (PLEASE REFER TO WRITTEN SPECIFICATIONS FOR ADDITIONAL REQUIREMENTS)

1. THIS DISTANCE SHALL BE 10' MINIMUM WITH ROOT BARRIER AND 15' MINIMUM IF NO ROOT BARRIER IS USED- FOR LARGE PALMS OR CANOPY TREES, FOR SMALL PALM TREES OR SMALL TREES, THIS DISTANCE SHALL BE 7' MINIMUM WITH ROOT BARRIER AND 10' IF NO ROOT BARRIER IS USED.
2. ALL ROOT BARRIERS SHALL BE 4' MINIMUM FROM ALL UTILITIES.
3. THE INSTALLATION OF ROOT BARRIERS SHALL BE COORDINATED WITH THE UTILITY OWNER AND INSPECTED PRIOR TO BACKFILLING. ALL ROOT BARRIERS SHALL EXTEND UP TO FINISHED GRADE.
4. ROOT BARRIERS SHALL BE MINIMUM 36\"/>

NOTES:

1. INSTALLATION TO BE COMPLETED IN ACCORDANCE WITH MANUFACTURER'S SPECIFICATIONS.
2. INSTALL AS REQUIRED, PER PLAN NOTES.
3. SUBMIT PRODUCT DATA FOR APPROVAL.

ROOT BARRIER BY: Century Root Barrier (714)632-7083
 (or) DeepRoot (800)458-7668

G Root Barrier
BARRIER DETAIL NTS

H Root Barrier Linear Application
BARRIER DETAIL NTS

1. ALL TREES SHALL BE PLUMB VERTICALLY WITHIN A TOLERANCE OF THREE DEGREES, UNLESS OTHERWISE DIRECTED BY OWNER'S REPRESENTATIVE.

1. MINIMUM OF NINE (9) GOOD PALM FRONDS; PRUNE AND TIE FRONDS WITH HEMP TWINE. SABAL PALMS TO BE SELECTIVELY "HURRICANE CUT", LEAVING ONLY NEWLY-EMERGING GROWTH.

1. FIND POINT WHERE TOPMOST ROOT EMERGES FROM TRUNK WITHIN 2\"/>

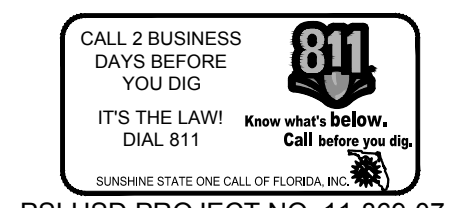

THIS ITEM HAS BEEN DIGITALLY SIGNED AND SEALED BY BENJAMIN V. JOHNSON, P.L.A., ON THE DATE ADJACENT TO THE SEAL.

PRINTED COPIES OF THIS DOCUMENT ARE NOT CONSIDERED SIGNED AND SEALED AND THE SIGNATURE MUST BE VERIFIED ON ANY ELECTRONIC COPIES.

Kimley»Horn
 © 2021 KIMLEY-HORN AND ASSOCIATES, INC.
 1615 S. CONGRESS AVE., SUITE 201,
 DELRAY BEACH, FL 33445
 PHONE: 561-330-2345 FAX: 561-863-8175
 WWW.KIMLEY-HORN.COM REGISTRY NO. 696

PROJECT GLADES
 PREPARED FOR
SEEFRED INDUSTRIAL
PROPERTIES, INC.
 CITY OF PORT ST. LUCIE
 FLORIDA

LANDSCAPE DETAILS

SHEET NUMBER
L-351

DATE: 07/18/2022

NO.	REVISIONS	DATE