

City of Port St. Lucie

121 SW Port St. Lucie Blvd.
Port St. Lucie, Florida 34984



Meeting Agenda

Monday, May 18, 2026

6:00 PM

City Hall, Room 188

Public Art Advisory Board

Please visit www.cityofpsl.com/tv for new public comment options.

1. **Call to Order**
2. **Roll Call**
3. **Determination of Quorum**
4. **Approval of Minutes**
 - 4.a Approval of the January 20, 2026, Public Art Advisory Board Meeting Minutes. [2026-450](#)
5. **Public to be Heard**
6. **New Business**
 - 6.a Oath of Office [2026-454](#)
 - 6.b Review of Sunshine Law, Public Records, Ethics and Robert's Rules of Order as They Apply to City Committee Members [2026-087](#)
 - 6.c Public Art Application: Ladybug Hideaway Alternative Equivalent Proposal Request for Wylder. [2026-451](#)
 - 6.d Status Update on the Installation of Sculptures for the Two Roundabouts Located on Paar Drive. [2026-453](#)
7. **Unfinished Business**
8. **Adjourn**

Notice: No stenographic record by a certified court reporter will be made of the foregoing meeting. Accordingly, any person who may seek to appeal a decision involving the matters noticed herein will be responsible for making a verbatim record of the testimony and evidence at said meeting upon which any appeal is to be based.

Notice: In accordance with the Americans with Disabilities Act of 1990, persons needing special accommodation to participate in this proceeding should contact the City Clerk's office at (772) 871-5157 for assistance.

As a courtesy to the people recording the meeting, please put your cell phone on silent.



Agenda Summary
2026-450

Agenda Date: 5/18/2026

Agenda Item No.: 4.a

Placement: Minutes

Action Requested: Motion / Vote

Approval of the January 20, 2026, Public Art Advisory Board Meeting Minutes.

Submitted By: Bethany Grubbs, AICP, Senior Planner/Public Art Program

Strategic Plan Link: The City's Goal of a high-performing city government organization.

Executive Summary (General Business): Approval of the January 20, 2026, Public Art Advisory Board Meeting Minutes.

Presentation Information: N/A

Staff Recommendation: Move that the Board approve the minutes.

Alternate Recommendations:

1. Move that the Board amend the recommendation and approve the minutes.
2. Move that the Board deny the minutes and provide staff direction.

Background: The PAAB held a regularly scheduled meeting on January 20, 2026.

Issues/Analysis: N/A

Financial Information: N/A

Special Consideration: N/A

Location of Project: N/A

Attachments:

1. January 20, 2026 Meeting Minutes

NOTE: All of the listed items in the "Attachment" section above are in the custody of the City Clerk. Any item(s) not provided in packets are available upon request from the City Clerk.

Internal Reference Number: N/A

City of Port St. Lucie
Public Art Advisory Board
Meeting Minutes - Draft

121 SW Port St. Lucie
Blvd.
Port St. Lucie, Florida
34984

Please visit www.cityofpsl.com/tv for new public comment options.

Tuesday, January 20, 2026

6:00 PM

City Hall, Room 188

1. Call to Order

A Regular Meeting of the PUBLIC ART ADVISORY BOARD of the City of Port St. Lucie was called to order by Chair Sullivan on January 20, 2026, at 6:05 p.m., at Port St. Lucie City Hall, Room 188, 121 SW Port St. Lucie Boulevard, Port St. Lucie, Florida & via Zoom.

2. Roll Call

Members Present:

Catherine Sullivan, Chair

Maddie Williams

Pamela Malingowski, Chair Pro Tem

Jill Todd, Alternate

Members Not Present:

Kelli Burgess, Vice Chair

Gina Duffy

Alice Zinn

Ryan Semblewski, Alternate

3. Determination of Quorum

It was determined that there was quorum.

4. Approval of Minutes

4.a Approval of the November 17, 2025, Public Art Advisory Board Meeting Minutes

[2026-092](#)

Chair Sullivan noted that under Item 7, the minutes should read “a large cultural fest in 2027”, not “next year.”

There being no further discussion, Ms. Williams moved to approve the amended minutes. Chair Pro-Tem Malingowski seconded the motion, which passed unanimously by voice vote.

5. Public to be Heard

There was nothing heard under this item.

6. New Business**6.a** Oath of Office for Public Art Advisory Board Members [2026-088](#)

(Clerk's Note: This item was heard after Item 5.)

The Deputy City Clerk administered the Oath of Office to reappointed members.

6.b Election of Officers [2026-091](#)

(Clerk's Note: This item was heard after Item 6d.)

Ms. Williams moved to nominate Kelli Burgess as Chair, Pamela Malingowski as Vice Chair and Catherine Sullivan as Chair Pro Tem. Ms. Malingowski seconded the motion, which passed unanimously by voice vote.

The Deputy City Clerk counted the ballots and confirmed Ms. Burgess as Chair, Ms. Malingowski as Vice Chair, and Ms. Sullivan as Chair Pro Tem. Ms. Williams moved to approve the ballots as counted. Ms. Malingowski seconded the motion, which passed unanimously by voice vote.

6.c Review of Sunshine Law, Public Records, Ethics and Robert's Rules of Order as They Apply to City Committee Members [2026-087](#)

Ms. Williams moved to table Sunshine Training to the next PAAB meeting. Ms. Malingowski seconded the motion, which passed unanimously by voice vote.

6.d Review the Selection Committee's Recommendation for the Installation of Sculptures for Two Roundabouts Located on Paar Drive [2026-093](#)

(Clerk's Note: This item was heard after Item 6a.)

(Clerk's Note: A PowerPoint was shown at this time.) Josh Lapp, Designing Local, gave a brief presentation on the Selection Committee's recommendation for the installation of sculptures for the two roundabouts for Paar Drive. He explained that Michael McLaughlin's pieces were not final and that the artist would engage with the community to finalize his pieces. He also noted that the three pieces would be located within a single roundabout. Ms. Sullivan added that the Selection Committee had discussed Vito Di Bari's Crane piece, agreeing that it was beautiful and a strong fit; however, they felt a roundabout was not an appropriate setting. Instead, they believed a more prominent, highly visible location, such as City Hall, would be more suitable.

Ms. Malingowski moved to recommend approval of Michael McLaughlin's & Molly Mason's (without the snake) art pieces for the Paar Roundabouts to the City Council. She also recommended that the City Council purchase Vito Di Bari's Crane piece to be used in a prominent location to be determined in the future. Ms. Williams seconded the motion, which passed unanimously by voice vote.

7. Unfinished Business

Ms. Sullivan stated that the City's Treasure Map needed to be completed as it was being sent out with promotional information. Ms. Todd moved recommend that the City's Treasure Map discussion be included on the agenda for the next meeting. Ms. Williams seconded the motion, which passed unanimously by voice vote.

8. Adjourn

There being no further business, the meeting was adjourned at 6:52 p.m.

Catherine Sullivan, Chair Pro Tem

Shanna Donleavy, Deputy City Clerk



Agenda Summary

2026-454

Agenda Date: 5/18/2026

Agenda Item No.: 6.a

Placement: New Business

Action Requested: Motion / Vote

Oath of Office

Submitted By: Bethany Grubbs, AICP, Senior Planner/Public Art Program

Strategic Plan Link: The City's Goal of a high-performing city government organization.

Executive Summary (General Business): Administer the Oath of Office to Kelli Burgess.

Presentation Information: The City Clerk shall issue the Oath of Office.

Staff Recommendation: N/A

Background: In order to conduct business on behalf of the Port St. Lucie City Council, regular and alternate members being appointed shall be required to take the Oath of Office prior to conducting formal business.

Issues/Analysis: N/A

Financial Information: N/A

Special Consideration: N/A

Location of Project: N/A

Attachments: N/A

NOTE: All of the listed items in the "Attachment" section above are in the custody of the City Clerk. Any item(s) not provided in packets are available upon request from the City Clerk.

Internal Reference Number: N/A



Agenda Summary

2026-087

Agenda Date: 5/18/2026

Agenda Item No.: 6.b

Placement: New Business

Action Requested: Motion / Vote

Review of Sunshine Law, Public Records, Ethics and Robert's Rules of Order as They Apply to City Committee Members

Submitted By: Bethany Grubbs, AICP, Senior Planner/Public Art Program

Strategic Plan Link: The City's Goal of a high-performing city government organization.

Executive Summary (General Business): The City Attorney's Office will provide a presentation to the committee members as a refresher regarding how Sunshine Law, Public Records, Ethics, and Robert's Rules of Order are applied to the Public Art Advisory Board.

Presentation Information: A presentation will be provided by Russell Ward, Deputy City Attorney, City Attorney's Office.

Staff Recommendation: Move that the Board hear the presentation and discuss any questions.

Background: Annual training includes a presentation on Sunshine Law, Public Records requirements, Ethics, and Robert's Rules of Order, all of which apply to members of the Public Art Advisory Board.

Issues/Analysis: N/A

Financial Information: N/A

Special Consideration: N/A

Location of Project: N/A

Attachments:

1. Sunshine Law Presentation (2026)

NOTE: All of the listed items in the "Attachment" section above are in the custody of the City Clerk. Any item(s) not provided in packets are available upon request from the City Clerk.

Internal Reference Number: N/A

Sunshine Law, Public Records, Ethics, & Robert's Rules of Order



City of Port St. Lucie – City Attorney's Office
(772) 871-5294

Sunshine Law



Overview:



- The Florida Legislature established a right for persons to:
 - Receive notice of meetings of municipal councils and boards;
 - Attend meetings of municipal councils and boards;
 - Access the record of said meetings;
- This law is codified in Chapter 286, Florida Statutes and an amendment to the Florida Constitution was approved providing a constitutional right for any person to access public meetings.
- There is both a statutory and constitutional right to open access of municipal meetings.



What is a public meeting?

Any gathering between "two or more members" of the Council, City board, or committee to discuss a matter which foreseeably will come before them.

Must be in
the sunshine



Gatherings not in the Sunshine:



Examples:

Staff meetings; Council members attending meetings of another public board (the public board will have to comply); discussions between members of different bodies; council members attending a privately sponsored forum; council members attending a social event.



Notice:

Events & Meetings

Regular City Council

Date: 01/08/2024 1:00 PM - 4:59 PM
Location: City Hall
[121 S.W. Port St. Lucie Blvd.](#)
[Port St. Lucie, Florida 34984](#)

 [Add to my Calendar](#)

Regular City Council Meetings happen every second Monday of the month at 1 p.m. and every fourth Monday of the month at 6 p.m., except when those days fall on a holiday at which point the meeting will take place on the next business day.

[View Agenda](#)

Sign up to receive agendas by email by visiting psl.legistar.com and registering your email the top of the page.

There are 5 ways to watch a public meeting:

1. Watch in person at [Port St. Lucie City Hall](#)
2. Watch on [Facebook @cityofpsl](#)
3. Watch the [PSL TV Live Stream](#) on any device
4. PSL TV is available on channel 20 on Xfinity and Blue Stream Fiber.
5. Visit psl.legistar.com for all meeting agendas and video recordings.

Public Comments:

- [Fill out the Comments to be Heard Form](#): All comments must be received 2 hours prior to the meeting start time. City Staff will enter all comments received into the official record. Comments are subject to compliance with the rules of council and decorum. Comments submitted online will not be read aloud during the meeting but will be entered into the official record by City Staff. Any email received by the City on a non-agenda topic, requesting it to be considered at Public to be Heard, shall be distributed to the Council members prior to the meeting and retained by the City Clerk as a public record.

- Notice: rule of thumb is at least seven days notice for a regular meeting, under ideal circumstances. Different notice requirements for special meetings.
- Notice must detail the time and place of the meeting. Agenda is *always* preferred.
- Meeting site must be sufficient in size and in accessible location so that the public may attend.

Record:

City of Port St. Lucie
Planning and Zoning Board
Meeting Minutes

Deborah Beutel, Chair
Peter Previte, At-Large
Eric Reikenis, At-Large
Melody Creese, Alternate
Peter Louis Spatara, Alternate

121 SW Port St. Lucie
Blvd.
Port St. Lucie, Florida
34984

Please visit www.cityofpsl.com/tv for new public comment options.

Tuesday, December 5, 2023 6:00 PM Council Chambers, City Hall

1. Meeting Called to Order
A Regular Meeting of the Planning and Zoning Board of the City of Port St. Lucie was called to order by Chair Beutel at 6:00 PM on December 5, 2023, at Port St. Lucie City Hall, 121 SW Port St. Lucie Boulevard, Florida.
2. Roll Call
Members Present:
Deborah Beutel, Chair
Peter Previte
Eric Reikenis
Melody Creese
Peter Spatara
3. Determination of a Quorum
Chair Beutel confirmed there was a quorum.
4. Pledge of Allegiance
Chair Beutel led the assembly in the Pledge of Allegiance.

- Minutes of a public meeting shall be taken promptly and made available for inspection.
- Minutes may be a brief summary or a verbatim transcript.
- Video taping does not substitute for meeting minutes but can be done in addition.

Failure to Comply:



Fines or Jail Time:

A “knowing” violation is a second-degree misdemeanor punishable by a fine of up to \$500 or any higher amount equal to double the pecuniary gain to the offender or pecuniary loss suffered by the victim, 60 days in jail, and court costs.



Elected Officials:

Suspension from office may occur if charged with a misdemeanor. A conviction may result in removal from office.



For the City:

Violations leave the City vulnerable to civil litigation and an awarding of attorneys’ fees.



Failure to Comply:

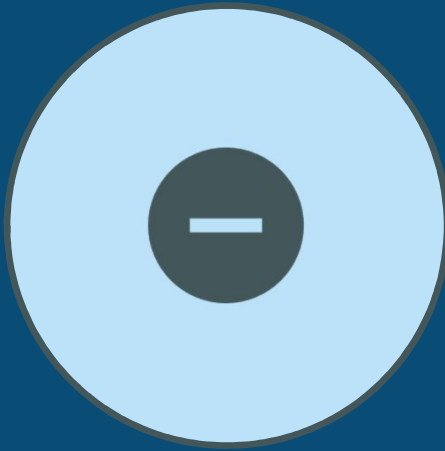

Nullify Actions at Issue:

Decisions made in violation of the Sunshine Law may be nullified costing the City time and money.



Public Records Law



Overview:



- First Public Record Law was in 1909, entitling “citizens” to access municipal records.
- Has expanded since and entitles “any person” access to municipal records. Codified in Chapter 119, Florida Statutes and in 1992, an amendment to the Florida Constitution.
- There is a statutory and constitutional right to access municipal records.



What are Public Records?

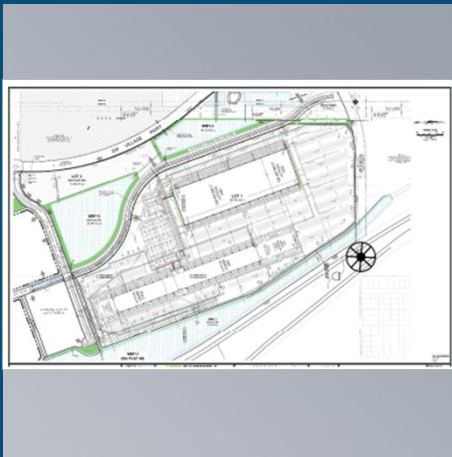

1

Materials made or received by the City;



2

In connection with official business and used to;



3

Perpetuate, communicate or formalize knowledge of some type.



Materials:



Include:

Papers (documents, letters, maps, faxes, books, etc.), electronic files/papers (email, data processing files, calendar, text messages, and internet posts, such as social media), photographs, videos, audio recordings.



Official City Business



Include:

Materials sent or received by employees in connection with their job, materials sent or received by Council or Board members in connection with their official capacity. Those of a personal nature are not City business.



Intended to perpetuate, communicate or formalize knowledge:



Include:

Email sent or received by Council members to constituents about an upcoming ordinance vote, draft documents shown to others for review or comment, taking meeting minutes, surveys sent out by the City, notes used to create documents for distribution. Intent and purpose is important.



Who must comply with Public Records:



- Members of the City Council, City officials and all City employees, City Board and Committee members, and City Volunteers.
- Store public records in your control in an organized filing system. You are the custodian of any record under your control.
- Only the City Clerk's office is permitted to destroy records in accordance with the Record Retention Schedule

How does a person gain access to a public record?

- A person may contact any City employee to make public records request to inspect and/or copy a record.
- The request may be in writing OR made verbally and no explanation or reason is needed (request may be anonymous).
- A person may take photographs of the record while they are in the possession, custody and control of the records custodian.

How does the City respond:

- Response is a governmental service and must be done promptly and the request must be acknowledged within 48 hours of receiving the request.
- Compiles the request, whether electronically or paper copies, and provides necessary equipment for inspection or copying.
- There are 1,084 exemptions and whether it is exempt or confidential is a question directed towards the City Attorney's Office

Exempt v. Confidential

119.071 General exemptions from inspection or copying of public records.—

(1) AGENCY ADMINISTRATION.—

(a) Examination questions and answer sheets of examinations administered by a governmental agency for the purpose of licensure, certification, or employment are exempt from s. 119.07(1) and s. 24(a), Art. I of the State Constitution. A person who has taken such an examination has the right to review his or her own completed examination.

(b)1. For purposes of this paragraph, "competitive solicitation" means the process of requesting and receiving sealed bids, proposals, or replies in accordance with the terms of a competitive process, regardless of the method of procurement.

2. Sealed bids, proposals, or replies received by an agency pursuant to a competitive solicitation are exempt from s. 119.07(1) and s. 24(a), Art. I of the State Constitution until such time as the agency provides notice of an intended decision or until 30 days after opening the bids, proposals, or final replies, whichever is earlier.

3. If an agency rejects all bids, proposals, or replies submitted in response to a competitive solicitation and the agency concurrently provides notice of its intent to reissue the competitive solicitation, the rejected bids, proposals, or replies remain exempt from s. 119.07(1) and s. 24(a), Art. I of the State Constitution until such time as the agency provides notice of an intended decision concerning the reissued competitive solicitation or until the agency withdraws the reissued competitive solicitation. A bid, proposal, or reply is not exempt for longer than 12 months after the initial agency notice rejecting all bids, proposals, or replies.

(c) Any financial statement that an agency requires a prospective bidder to submit in order to prequalify for bidding or for responding to a proposal for a road or any other public works project is exempt from s. 119.07(1) and s. 24(a), Art. I of the State Constitution.

(d)1. A public record that was prepared by an agency attorney (including an attorney employed or retained by the agency or employed or retained by another public officer or agency to protect or represent the interests of the agency having custody of the record) or prepared at the attorney's express direction, that reflects a mental impression, conclusion, litigation strategy, or legal theory of the attorney or the agency, and that was prepared exclusively for civil or criminal litigation or for adversarial administrative proceedings, or that was prepared in anticipation of imminent civil or criminal litigation or imminent adversarial administrative proceedings, is exempt from s. 119.07(1) and s. 24(a), Art. I of the State Constitution until the conclusion of the litigation or adversarial administrative proceedings. For purposes of capital collateral litigation as set forth in s. 27.7001, the Attorney General's office is entitled to claim this exemption for those public records prepared for direct appeal as well as for all capital collateral litigation after direct appeal until execution of sentence or imposition of a life sentence.

2. This exemption is not waived by the release of such public record to another public employee or officer of the same agency or any person consulted by the agency attorney. When asserting the right to withhold a public record pursuant to this paragraph, the agency shall identify the potential parties to any such criminal or civil litigation or adversarial administrative proceedings. If a court finds that the document or other record has been improperly withheld under this paragraph, the party seeking access to such document or record shall be awarded reasonable attorney's fees and costs in addition to any other remedy ordered by the court.

(e) Any videotape or video signal that, under an agreement with an agency, is produced, made, or received by, or is in the custody of, a federally licensed radio or television station or its agent is exempt from s. 119.07(1).

(f) Data processing software obtained by an agency under a licensing agreement that prohibits its disclosure and which software is a trade secret, as defined in s. 812.081, and agency-produced data processing

- If information is designated confidential in the statutes, the information is not subject to inspection by the public and may only be released to the persons or organizations in the statute.
- If records are not confidential but are only exempt from the Public Records Act, the exemption does not prohibit the showing of such information.

Failure to Comply:



1

A “knowing” violation is a first-degree misdemeanor;



2

All other violations are noncriminal and punishable by fines;



3

Violations leave the City vulnerable to civil litigation and an awarding of attorneys fees.



Ethics



Overview:

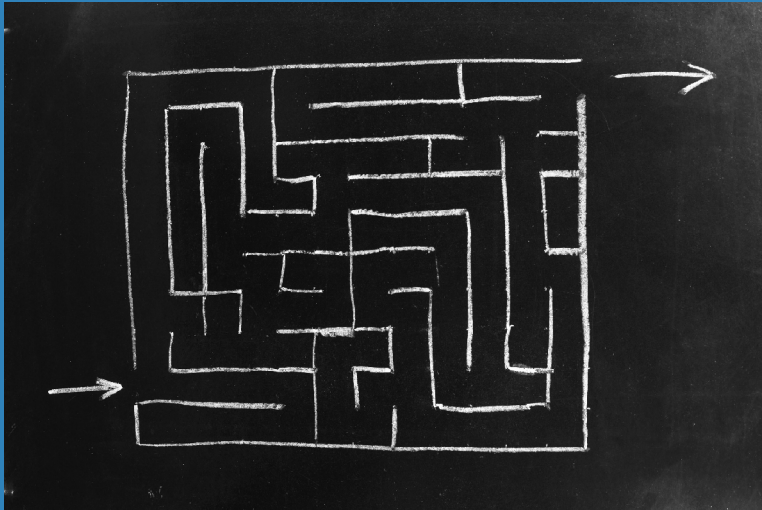

- There are several legal restrictions and reporting requirements falling within four categories:
 - Laws pertaining to prohibited or restricted conduct (including misuse of public position, conflicts of interest, nepotism, voting conflicts, prohibited disproportionate benefit, etc.
 - Laws pertaining to bribes, gifts, honoraria, and expenditures, etc.
 - Government transparency laws involving financial disclosure
 - Laws pertaining to executive branch lobbying activity



Public Officers per s. 112, Florida Statutes



Definition:

Includes any person elected or appointed to hold office in any agency, including any person serving on an advisory body.



Public Officers cannot:



- Solicit or accept anything of value, including a gift, loan reward, promise of future employment, favor, or service, based upon any understanding of a vote, official action, or judgment being influenced.
- Acting in official capacity, directly or indirectly purchase, rent, or lease any realty goods, or services for his/her own agency from any business entity of which the officer or director spouse or child is a director has a material interest.
- Accept any compensation or payment that such officer should or, with the exercise of reasonable care, should know, that it was given to influence a vote or action.

Cont'd:



- Corruptly use or attempt to use their position to secure a special privilege, benefit, or exemption.
Have or hold any employment or contractual relationship that will create a continuing or reoccurring conflict
- Hold any employment or contractual relationship with any business entity or agency which is subject to the regulation of, or is doing business with, the agency of which he or she is an officer or employee
- Use information not disclosed to the public for personal gain or benefit.

Voting Conflicts



Conflict:

No municipal officer shall vote in a capacity upon any measure which would inure to his or her special private gain or loss.

Must:

Publicly state to the assembly the nature of the officer's interest in the matter and, within 15 days after the vote, disclose the nature of the interest in a memorandum filed with the Clerk.

Special Private Gain or Loss:

Size of the class affected by the vote, the nature of the interests involved, the degree to which the interests of all members of the class are affected by the vote, or the degree to which the officer receives a greater benefit or harm.



Robert Rules of Order



ROBERTS RULES CHEAT SHEET

To:	You say:	Interrupt Speaker	Second Needed	Debatable	Amendable	Vote Needed
Adjourn	"I move that we adjourn"	No	Yes	No	No	Majority
Recess	"I move that we recess until..."	No	Yes	No	Yes	Majority
Complain about noise, room temp., etc.	"Point of privilege"	Yes	No	No	No	Chair Decides
Suspend further consideration of something	"I move that we table it"	No	Yes	No	No	Majority
End debate	"I move the previous question"	No	Yes	No	No	2/3
Postpone consideration of something	"I move we postpone this matter until..."	No	Yes	Yes	Yes	Majority
Amend a motion	"I move that this motion be amended by..."	No	Yes	Yes	Yes	Majority
Introduce business (a primary motion)	"I move that..."	No	Yes	Yes	Yes	Majority

The above listed motions and points are listed in established order of precedence. When any one of them is pending, you may not introduce another that is listed below, but you may introduce another that is listed above it.

To:	You say:	Interrupt Speaker	Second Needed	Debatable	Amendable	Vote Needed
Object to procedure or personal affront	"Point of order"	Yes	No	No	No	Chair decides
Request information	"Point of information"	Yes	No	No	No	None
Ask for vote by actual count to verify voice vote	"I call for a division of the house"	Must be done before new motion	No	No	No	None unless someone objects
Object to considering some undiplomatic or improper matter	"I object to consideration of this question"	Yes	No	No	No	2/3
Take up matter previously tabled	"I move we take from the table..."	Yes	Yes	No	No	Majority
Reconsider something already disposed of	"I move we now (or later) reconsider our action relative to..."	Yes	Yes	Only if original motion was debatable	No	Majority
Consider something out of its scheduled order	"I move we suspend the rules and consider..."	No	Yes	No	No	2/3
Vote on a ruling by the Chair	"I appeal the Chair's decision"	Yes	Yes	Yes	No	Majority

The motions, points and proposals listed above have no established order of preference; any of them may be introduced at any time except when meeting is considering one of the top three matters listed from the first chart (Motion to Adjourn, Recess or Point of Privilege).

Role of the Chairperson:



Includes:

Calling the meeting to order, announces the purpose and topic of items to be discussed, recognizes members on the floor who are going to speak, protects quorum from digressing from topic on the floor, protects integrity of meeting from disruption or distraction

Does not:

Make motions or proposals, close debate before every member has had the opportunity to speak



Decorum in debate:



- The speaker must be recognized by the Chairperson before speaking, should limit speech to ten minutes, and should not speak more than twice on the motion.
- Decorum should be kept at all times including confining statements to merits of pending questions., not attacking a member's motives for a motion, not speaking adversely on an item that is not pending or has been finalized.
- A member may not interrupt except in urgent situations such as a point of order, raising a question of privilege, or calling attention that that speaking rules are not being observed.

Accomplish in meetings:



Main Motion

“Madame Chairman, I move that...”



Amending a Motion

“I move that the motion be amended by adding the following words/striking the following words/striking and adding in their place...”



Limit Discussion

“Madam Chair, “I move to limit discussion to two minutes per speaker”



Additional considerations:



- Quorum: the minimum number of voting members who must be present at a properly called meeting to conduct business.
- Motions cannot be made by the Chair and motions must be seconded by someone other than the Chair and the person making the motion.
- Only one motion can be discussed at a time. Everyone has the right to participate in a discussion but only urgent matters may interrupt a speaker.

Resolution 24-R59



City Rules and Regulations



- Quorum is a majority of the board's size regardless of vacant seats.

Alternate Members shall be contacted and substitute for absent members on a rotating basis.

- Alternate members shall have all rights afforded to voting members except making motions, engaging in discussion/debate once a motion is on the table, and voting. Alternate members may not discuss during quasi-judicial proceedings.

Cont'd



- Any board member wishing to resign shall submit a written notice to the City Clerk announcing their resignation and shall not be eligible for reappointment for a period of one year from resignation, unless good cause is shown.
- Alternate members may be elevated to voting members or new applications may be reviewed to fill vacant seats
- A member may only serve as chair for one consecutive year

Thank you

Any questions?





Agenda Summary

2026-451

Agenda Date: 5/18/2026

Agenda Item No.: 6.c

Placement: New Business

Action Requested: Motion / Vote

Public Art Application: Ladybug Hideaway Alternative Equivalent Proposal Request for Wylder.

Submitted By: Bethany Grubbs, AICP, Senior Planner/Public Art Program

Strategic Plan Link: The City's Goal to enjoy culture, nature and fun activities.

Executive Summary (General Business): Four Seasons at Wylder Neighborhood Association, Inc. is requesting approval to relocate the previously approved artwork *Ladybug Hideaway* by Mark Fuller. The proposal would move the installation from the commercial plazas on the north side of the development to a nature path located inside of an open space tract, along an arterial roadway within a residential area to the south.

Presentation Information: The applicant will provide a presentation.

Staff Recommendation: The Planning and Zoning Department recommends that the Board review and discuss the application and provide a formal recommendation to City Council regarding the proposed artwork relocation.

Alternate Recommendations:

1. If the Board finds that sufficient information has been provided, the Board may recommend approval of the proposal with comments. Any comments must be addressed prior to scheduling the item for City Council consideration.
2. The Board may choose not to recommend approval of the proposal and may provide direction to staff on any revisions or additional information needed.

Background: The artwork was approved by Council on May 13, 2024, through Resolution 24-R34 an Alternative Equivalent Proposal under Section 162.08. The original concept consists of twelve sculptural blades incorporating nineteen species of ladybugs, placed within two 5,100-square-foot plazas on the commercial tracts at the intersection of Midway Road and Wylder Parkway. The approved location was intended to provide an opportunity for the public to walk up to and through the art piece while exploring the various ladybugs for educational purposes. The location within a future commercial development was intended to provide parking and safe public access to the art work.

The developer reports that updated commercial access planning shifted vehicular movements and introduced increased traffic conflicts for pedestrians approaching or leaving the artwork. The applicant also notes that commercial out-parcels cannot be relied upon to activate or visually engage the originally approved art plazas. The developer proposes to consolidate the two plazas into a single installation within the residential area,

adjacent to a nature path and preserve.

In March 2026, the developer notified staff of their intent to relocate the artwork on a public right-of-way along a nature path with no parking. Any change in location requires returning to the PAAB and City Council for approval.

Issues/Analysis: This request is submitted as an Alternative Equivalent Proposal (Option 4) under the Public Art Ordinance for the Wylder sculptures known as *Ladybug Hideaway*. The proposal includes twelve monumental public art pieces by Artist Mark Fuller, consisting of clusters of 8-, 10-, and 12-foot sculptural blades resembling silver and green grasses, featuring nineteen ladybug species.

The alternate equivalent proposal satisfies the public art requirements for POD 1, POD 2, POD 4, POD 5, POD 6A, POD 6B, POD 7, POD 8A, POD 8B, POD 8C, POD 9, Tract A, Tract B, Tract C, Founders Crossing East, and Founders Crossing West.

Per Section 162.08(d), the submittal must contain all information and meet all criteria outlined in Section 162.09 for including public art on private development. Required elements include:

The artwork must be located in an exterior place and the application must include:

1. Artist's qualifications, including resume and portfolio establishing the artist's credentials.
2. Detailed description and depiction of the work of art and its location on the site.
3. Drawings and renderings of the proposed work of art, in terms of size, scale, color, shape, and materials in sufficient detail to provide a clear understanding of the art.
4. Maintenance program required for the artwork.
5. Compliance with public accessibility (ADA) requirements.

The City may approve the alternative equivalent proposal if it finds that:

1. The alternative equivalent proposal will further the purposes of the City's Public Art Ordinance.
2. The proposed location of the alternative equivalent proposal is in reasonable proximity to the location of the site(s) generating the work of art requirement, in order to avoid clustering of all public art in one location.
3. The cost of the proposal will be equal to or greater than the cost of the public art assessment that would otherwise be required for each individual project.
4. The developer has established to the satisfaction of the City that the alternative equivalent proposal will create freely accessible public art in the City to an equal or greater extent than installation of public art on the individual project site or contribution to the Public Art Fund.

In approving a proposal, the City may impose reasonable conditions of approval requiring the developer to enter into agreements with the City or other public agencies or private parties to memorialize the legal obligations of all parties involved with the alternative equivalent proposal.

Financial Information: "Total construction costs" refers to the full cost of the approved improvements for a development project, excluding land value, as documented in the construction contract(s). With a projected construction cost of \$1,600,000.00, the project is close to meeting the minimum public art assessment threshold required under Section 162.08(20)(a)-(c) of the City Code. Based on an artwork appraisal of

\$1,530,850.78, any remaining difference will be paid as a monetary contribution to the Public Art Fund.

Upon completion of construction, Four Seasons at Wylder Neighborhood Association, Inc. intends to convey the land and responsibility for maintenance and operations to a Community Development District. The City Attorney's Office will need to review and approve any proposed agreements, deeds, etc.

Special Consideration: The proposed relocation would change how people can interact with the artwork. The original commercial location was meant to be a dedicated public space where anyone could walk up to the sculptures, look for the ladybugs, and enjoy the interactive elements. The new location is located on a path along Wylder Parkway, which is identified as an arterial roadway, that runs from Glades Cut Off Road and Midway Road. There is no parking associated with the artwork plaza; therefore, only pedestrians, primarily being the residents of the adjacent communities, will be able to access and engage with the site. The ordinance states that artwork must be "freely accessible". As a result, far fewer members of the general public are likely to see or interact with the artwork, and it shifts from a public-facing experience to a semi-public neighborhood feature.

Location of Project: The proposed location is south of the intersection of Midway Road and Wylder Parkway, along the west side of Wylder Parkway.

Attachments:

1. Project Narrative
2. Ladybug Hideaway Proposal
3. Artist's Resume
4. Site Plan
5. Hardscape Plan
6. Landscape Plan
7. Artwork Appraisal
8. Proposed Work Schedule
9. Sculpture Maintenance Plan
10. ADA Compliance Plan
11. Creditable Project List
12. Agent Authorization Form
13. Warranty Deed
14. Property Card

NOTE: All of the listed items in the "Attachment" section above are in the custody of the City Clerk. Any item(s) not provided in packets are available upon request from the City Clerk.

Internal Reference Number: N/A



April 9, 2026

VIA DIGITAL DELIVERY

Ms. Bethany Grubbs, AICP, Senior Planner / Public Art Program
Planning & Zoning Department
City of Port St Lucie
121 SW Port St. Lucie Boulevard
Port St. Lucie, FL 34984

RE: Ladybug Hideaway – Alternative Equivalent Proposal Request
City Project Number: P23-132

Dear Ms. Grubbs:

On behalf of GreenPointe, Midway Glades Developers, LLC, we are resubmitting the request for an Alternative Equivalent Proposal (Option 4) of the Public Art Ordinance specific to the proposed Wylder Ladybug Hideaway sculptures (P22-278).

The original concept for the public art envisioned two art plazas, mirroring each other, and on each side of Wylder Parkway. The location of each was to afford a link with the future commercial development to these two art plazas.

Issues started to arise late in 2024 and throughout last year when we focused on commercial development, primarily, car and truck access to both commercial plazas and in turn looking at how pedestrian access would function. While working with public works, it was determined that the primary vehicular movements would be occurring south of the proposed plazas, not to the north as we originally assumed, creating an intersection for pedestrians to navigate before arriving at the art and again as they left to return home.

In addition to the significant addition of navigating an intersection with high volumes of commercial traffic, we also started to realize that although the commercial centers will be nicely done and will maintain aesthetic oversight and consistency with Wylder, there will be little control or ability to dictate that out-parcels and commercial buildings engage with the plazas. Thus, creating two art plazas surrounded by commercial parking lot, Wylder Parkway and commercial traffic. This clearly paints a much different picture than our original vision. With all of that, and the initial fact that we had two plazas separated by a parkway and no convenient way to connect them, we pivoted back to one of our original locations and concepts.

Our new/old concept provides the opportunity to combine the original layout, two plazas, into a single experience, where the visitor can walk along a nature path and engage the art panels in a linear experience and adjacent to one of the largest wetland preserves within the Wylder property. This location also provides the public and residents with the benefit of the entirety of the art being installed at once and not in two phases and two separate locations.

This new, preferred location, is central to the entire Wylder community and more importantly leverages the Wylder Parkway multi-use system, encouraging residents to 'go outside' and reconnect with nature. The art itself, a series of grass blades of varying heights with ladybugs hiding throughout, has not changed, the art has been fabricated and awaiting its final home.

We have spent a large amount of time collaborating with artist Mark Fuller, to curate a meaningful linear pathway experience winding through the Ladybug Hideaway - a space where all ages can immerse themselves, find a quiet respite, and enjoy art and nature.

Again, our plan is to submit our amended public art proposal on April 15th to begin the formal process.

Please Note: We submitted notification last year requesting an extension of our original approval and time certain commitments and justifications for the reasons behind the relocation.

Enclosed with this letter, please find the following related materials:

2. Owners Authorization
3. Warranty Deed
4. Location Map
5. Art Submittal
6. Creditable Public Art Value
7. Opinion of Probable Cost
8. Site and Fire Hydrants Locations
9. Site Plan
10. Landscape Plan
11. Hardscape Plan
12. ADA Compliance Plan
13. Public Art Application
14. Artist Mark Fuller Portfolio
15. Sculpture – Material and Maintenance
16. Public Art Escrow
17. Restrictive Covenant
18. Construction Documents
19. Opinion of Probable Cost for Surety Bond
20. Proof Of Ownership
21. Utility Projection Information Form
22. Water Meter Sizing Calculations

Project Narrative:

Inspired by the tranquility found in vast fields of tall grass, Artist Mark Fuller envisions a space where individuals can escape the hustle and bustle of city life. The installation is composed of giant blades or leaves of grass evoking a sense of awe and wonder fostering a connection with the

natural world. Throughout the towering grass blades, 19 species of ladybugs are hiding within the leaves to entice exploring the installation and fostering a connection between individuals and the environment.

On behalf of GreenPointe, Midway Glades Developers, LLC, and Artis Mark Fuller, we are proud to make this application request and look forward to bringing to the residents of Wylder and the citizens of Port St. Lucie an iconic piece of public art and innovative public space.

Should you have any questions or need additional information, please feel free to contact me directly at (772)220-2100.

Sincerely,

Steven J. Sullivan
Lucido & Associates

Ladybug Hideaway

An
ART IN PUBLIC PLACES PROPOSAL
For
WYLDER / Greenpointe LLC

To The
City of Port St. Lucie, Florida

AUGUST 2024
MARCH 2026

INDEX:

1 of 15	Index & General Notes
2 of 15	Artist Statement
3 of 15	Perspective Rendering
4 of 15	Ladybug Pin Details
5 of 15	Typical Elevation
6 of 15	Typical Blade Group Elements
7 of 15	Sprout Cluster Fabrication Details
8 of 15	Sprout Cluster Typical Details
9 of 15	Parent Blade Fabrication Details
10 of 15	Parent Blade Cut Pattern Details
11 of 15	Parent Blade Fabrication Details
12 of 15	Parent Concrete Footer Layout & Details
13 of 15	Parent Footer Mounting Plates Layout & Details
14 of 15	Parent Footer Mounting Plates - Hole Pattern Details
15 of 15	Typical Parent Elevations



Ladybug Hideaway

Artist Statement

In creating this public art installation, I seek to capture the essence of nature and bring an immersive experience to the urban landscape.

Inspired by the tranquility found in vast fields of tall grass, I envisioned a space where individuals could escape the hustle and bustle of city life - if only for a moment. As a result this installation is composed of giant blades or leaves of grass.

The tall grass serves as a metaphor for the resilience and vitality of nature, pushing its way through the man-made environment to offer a momentary respite. The installation, arranged in a series of planter beds, not only transforms the environment but also prompts viewers to reconsider the intersection between urban development and the natural world.

The decision to elevate the height of the leaves to be well overhead of a person is deliberate - intended to evoke a sense of awe and wonder, encouraging participants to walk among the towering grass blade groupings. In doing so, they immerse themselves in a unique experience, fostering a connection with the natural world within an urban context.

I constructed a study model to sort out a format to tame the grass in a civilized manner. The inner side of the blades are sheathed with mirror-polished stainless steel, and sparkled reflections of the sky become tethered into the viewers' spatial experience. My intended effect of how a viewer in the midst will feel dwarfed was great, but something was missing. A lovable, whimsical resident was needed, so without hesitation a Ladybug was invited to make it her home.

My research uncovered 18 different types of ladybugs. By creating contemporary interpretations of them and hiding them throughout the installation I bring an added element of surprise and joyful splendor to the act of exploring the installation.

Beyond the aesthetic appeal, this installation serves as a reminder of the importance of preserving green spaces in our urban environments. It prompts us to reflect on the delicate balance between progress and the preservation of the natural world, encouraging a dialogue about the coexistence of man-made structures and the beauty of the organic.

Through this art piece, I hope to inspire a sense of harmony and appreciation for the natural world, fostering a connection between individuals and the environment. As we navigate the challenges of urbanization, let this installation stand as a testament to the enduring power and beauty found in the simplest elements of nature.







TYPES OF LADYBUGS

DESCRIPTION:
 ENAMEL PAINTED LADYBUG BODY W/ CLEARCOAT FINISH SURFACE-MOUNTED TO SECOND SURFACE OF SCULPTURAL BLADE ELEMENT. LIMIT USE TO ONE OF THESE UNIQUE VARIETIES WITHIN A SINGLE BLADE CLUSTER. POSITION AND PLACEMENT WITHIN THE BLADE CLUSTER IDEALLY TO BE EVASIVE TO DISCOVERY.

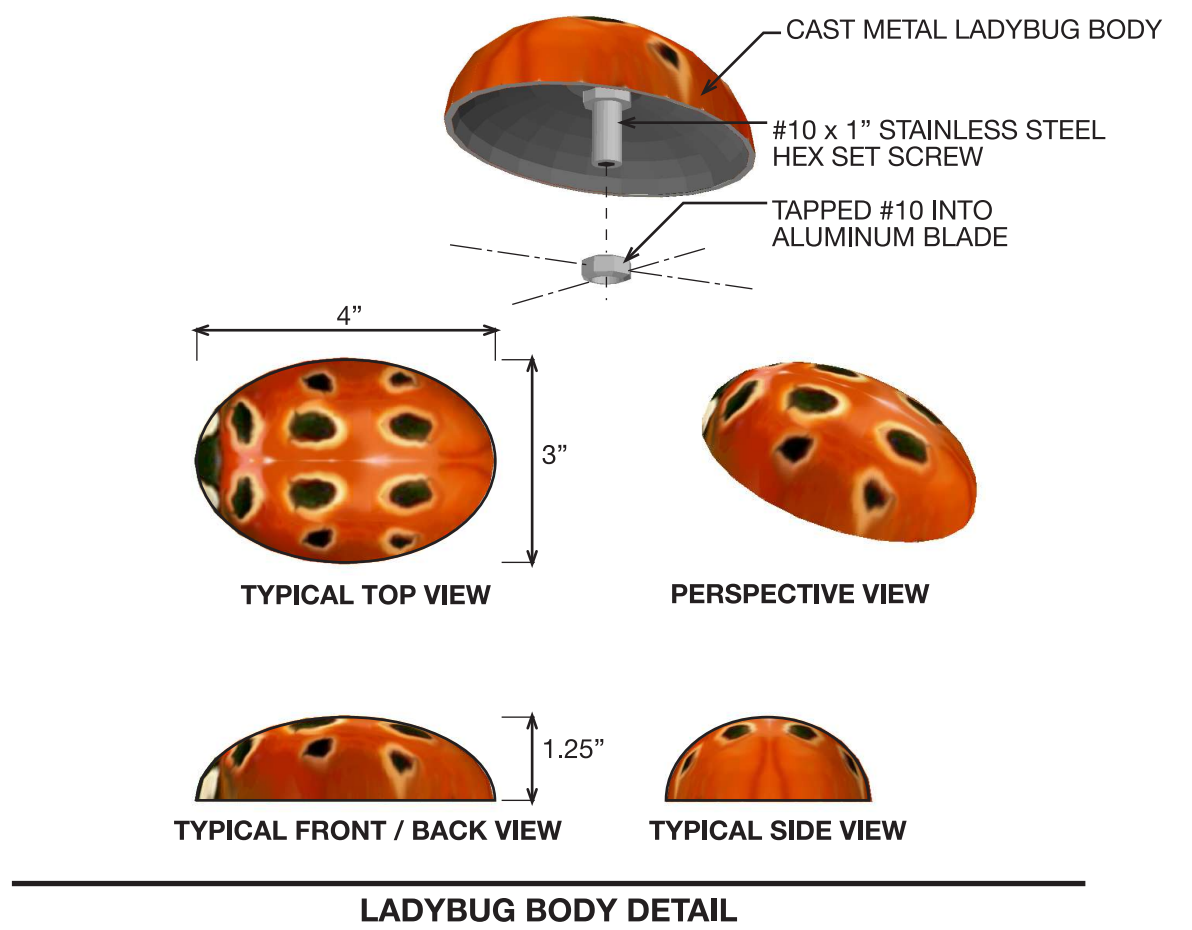

LADYBUG BODY DETAIL

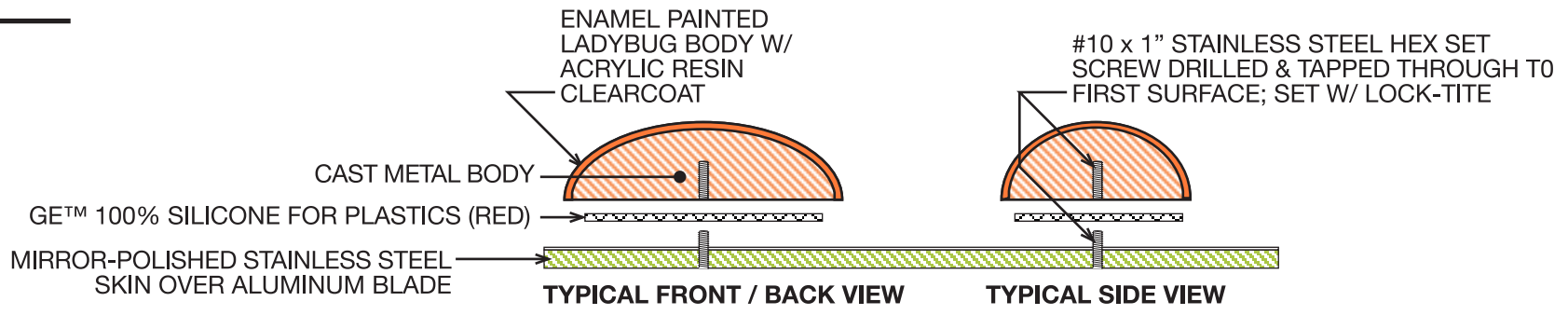

BODY MOUNTING DETAIL



TYPICAL ELEVATION

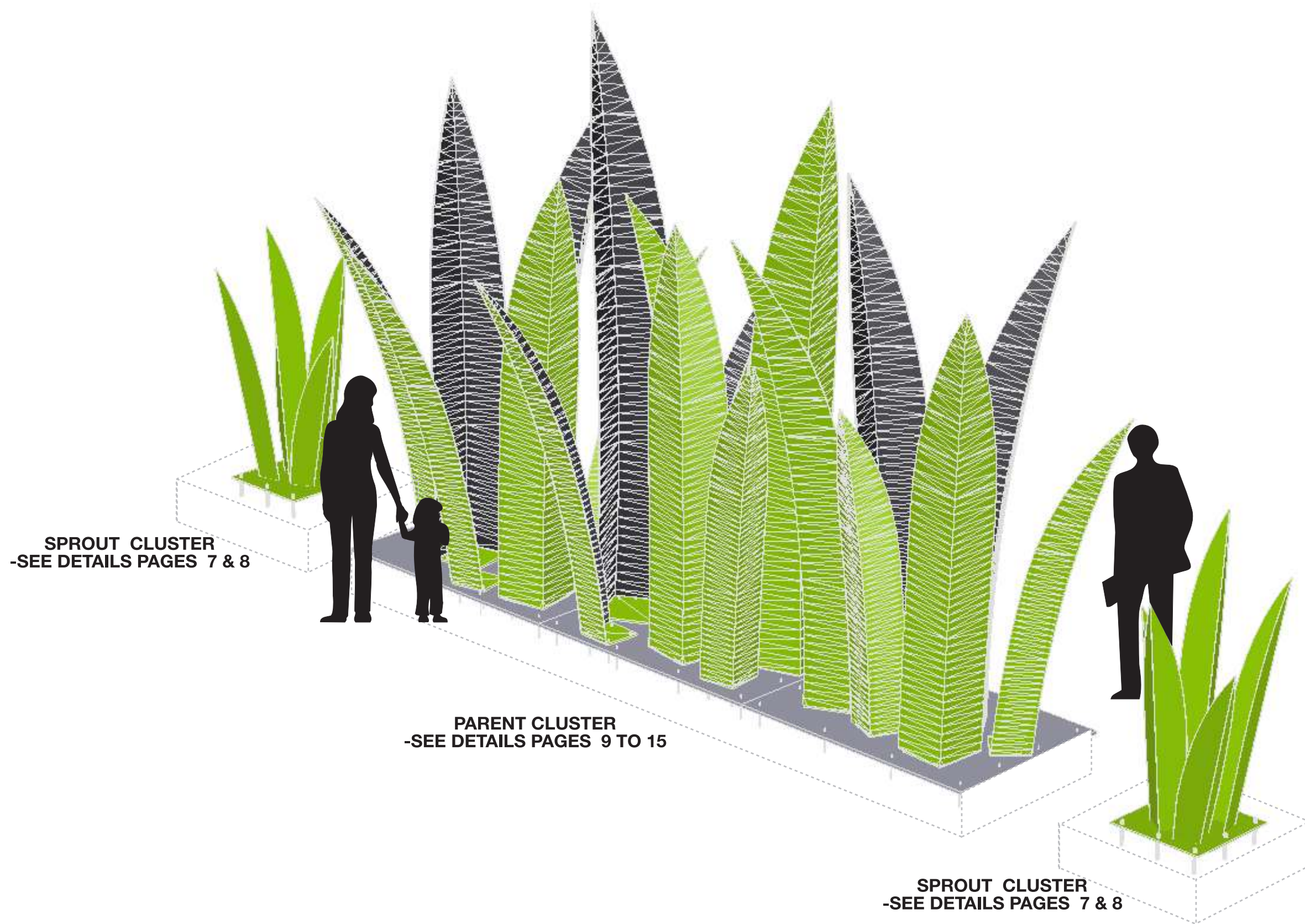

SPROUT CLUSTER
-SEE DETAILS PAGES 7 & 8

PARENT CLUSTER
-SEE DETAILS PAGES 9 TO 15

SPROUT CLUSTER
-SEE DETAILS PAGES 7 & 8

PERSPECTIVE RENDERING



FLAT PATTERN TOP VIEWS

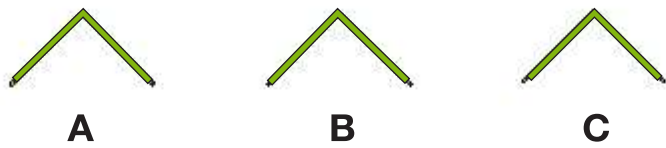

FORMED TOP VIEWS

4, 5, AND 6FT SCULPTURAL BLADES WELDED TO BASEPLATE

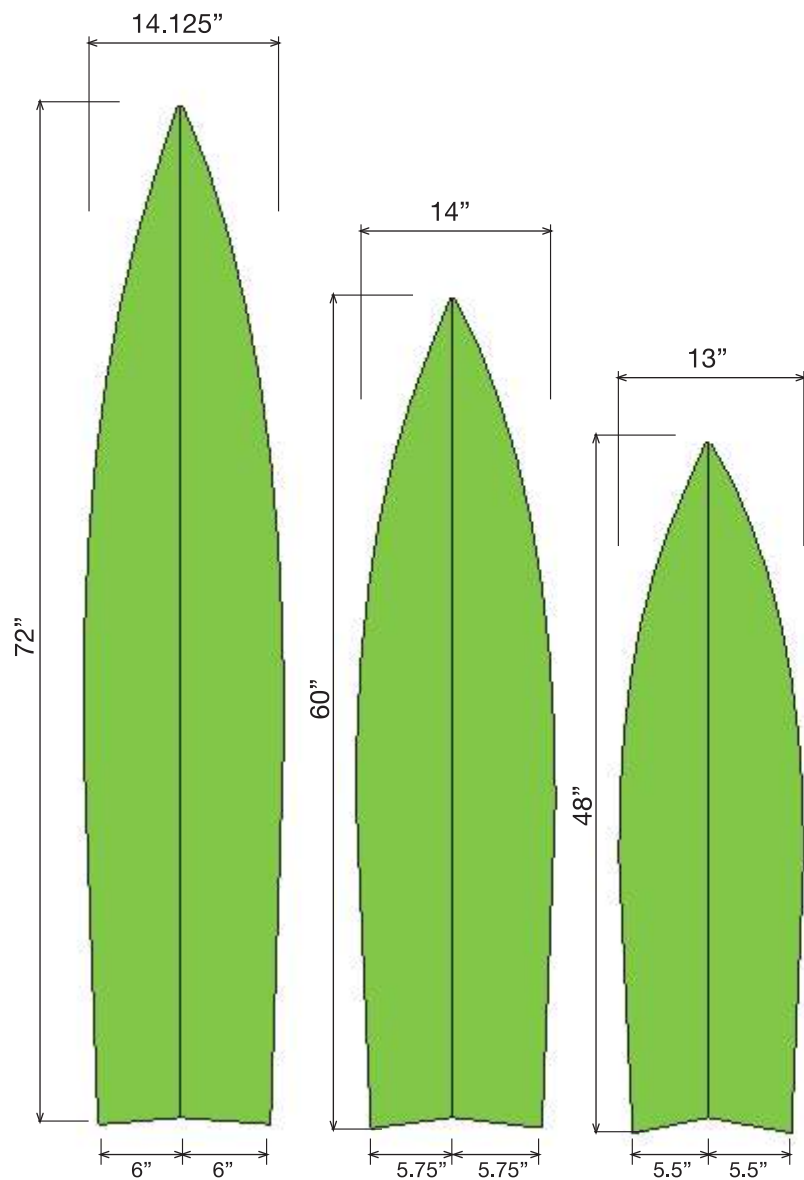
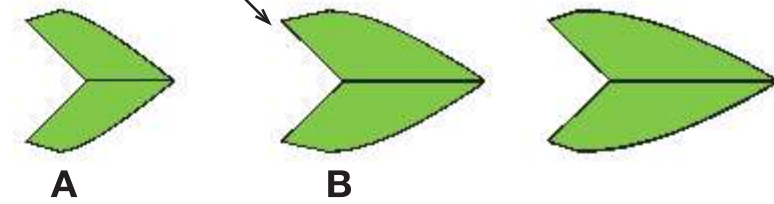

FLAT PATTERN LAYOUTS

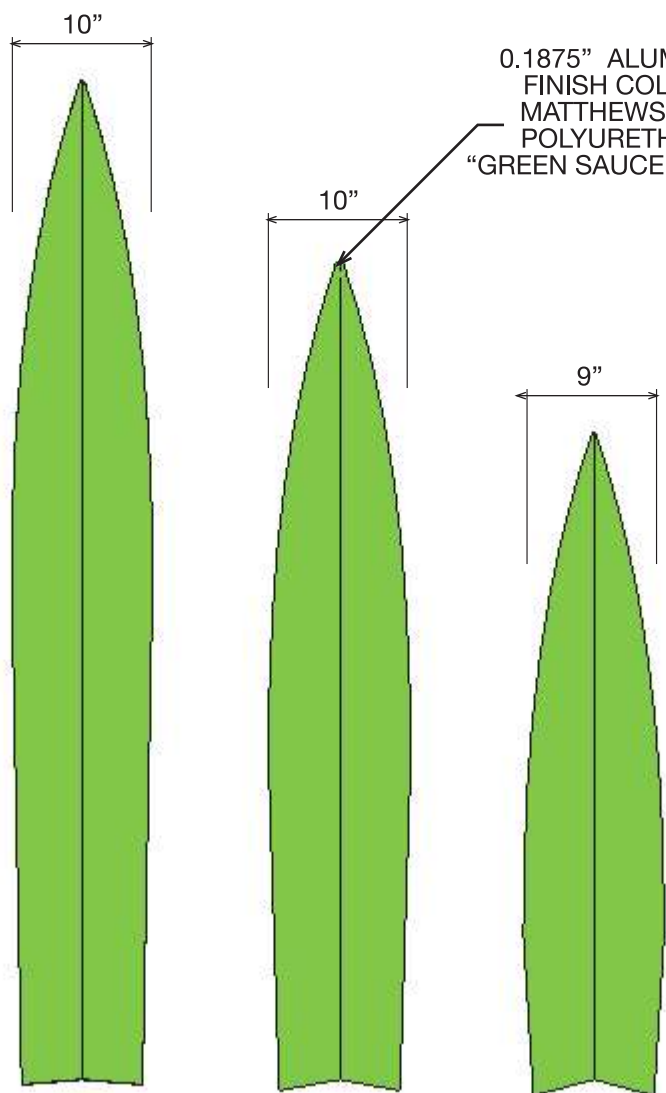

FORMED ELEVATIONS

0.1875" ALUMINUM BLADE. FINISH COLOR TO MATCH MATTHEWS MAP ACRYLIC POLYURETHANE MP00497 "GREEN SAUCE WITH LEMON"

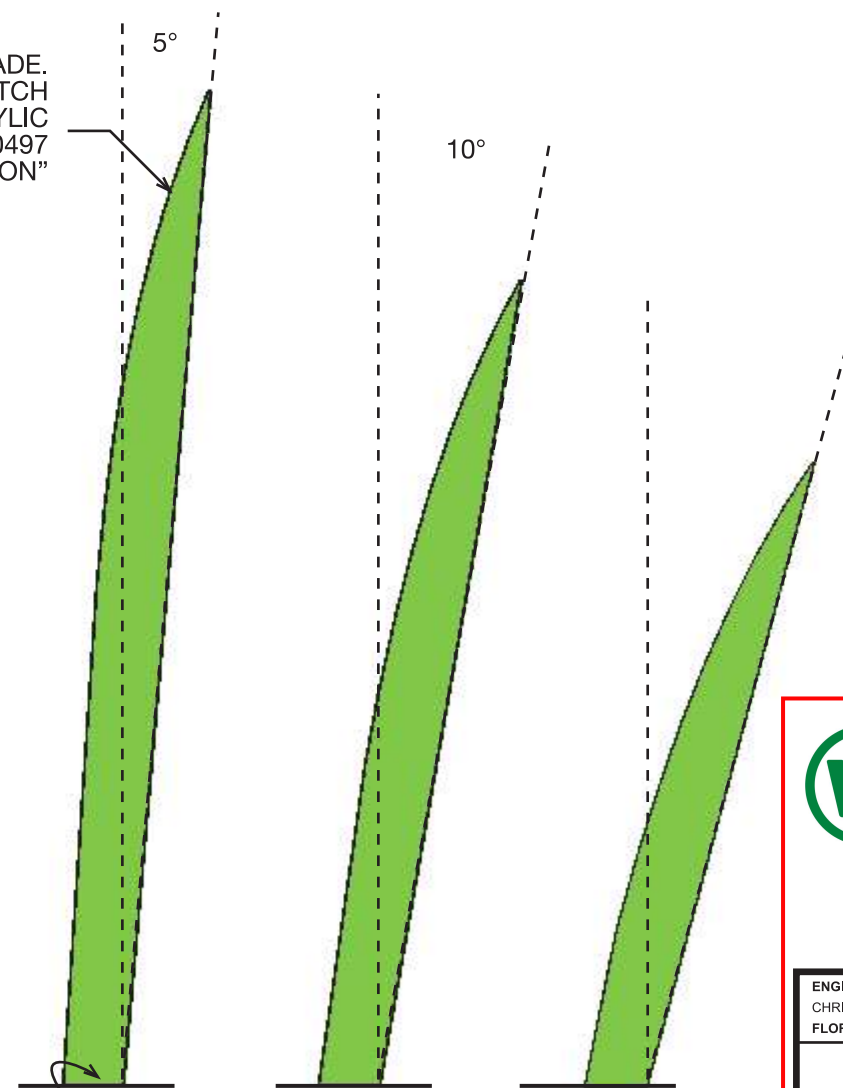

FORMED BLADES - WELD TO 0.375" ALUMINUM BASEPLATE ALL AROUND

FORMED MOUNTED SIDE VIEW

WGI
WGInc.com

2035 VISTA PARKWAY
WEST PALM BEACH, FL 33411
OFFICE - 561.687.2220
WGINC.COM
WGI PROJECT NUMBER 10800.00

ENGINEER OF RECORD:
CHRISTOPHER B. LAFORTE
FLORIDA P.E. LICENSE NO.: 76797

DATE:

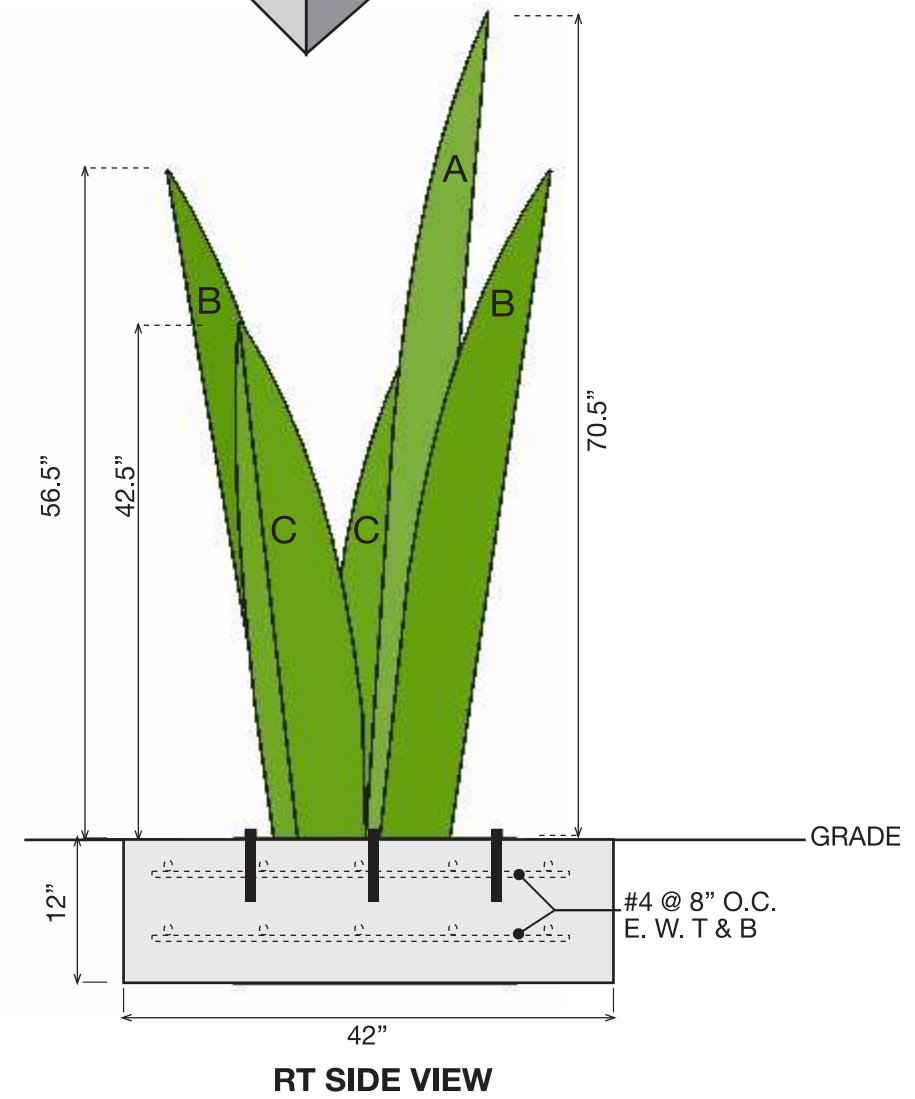
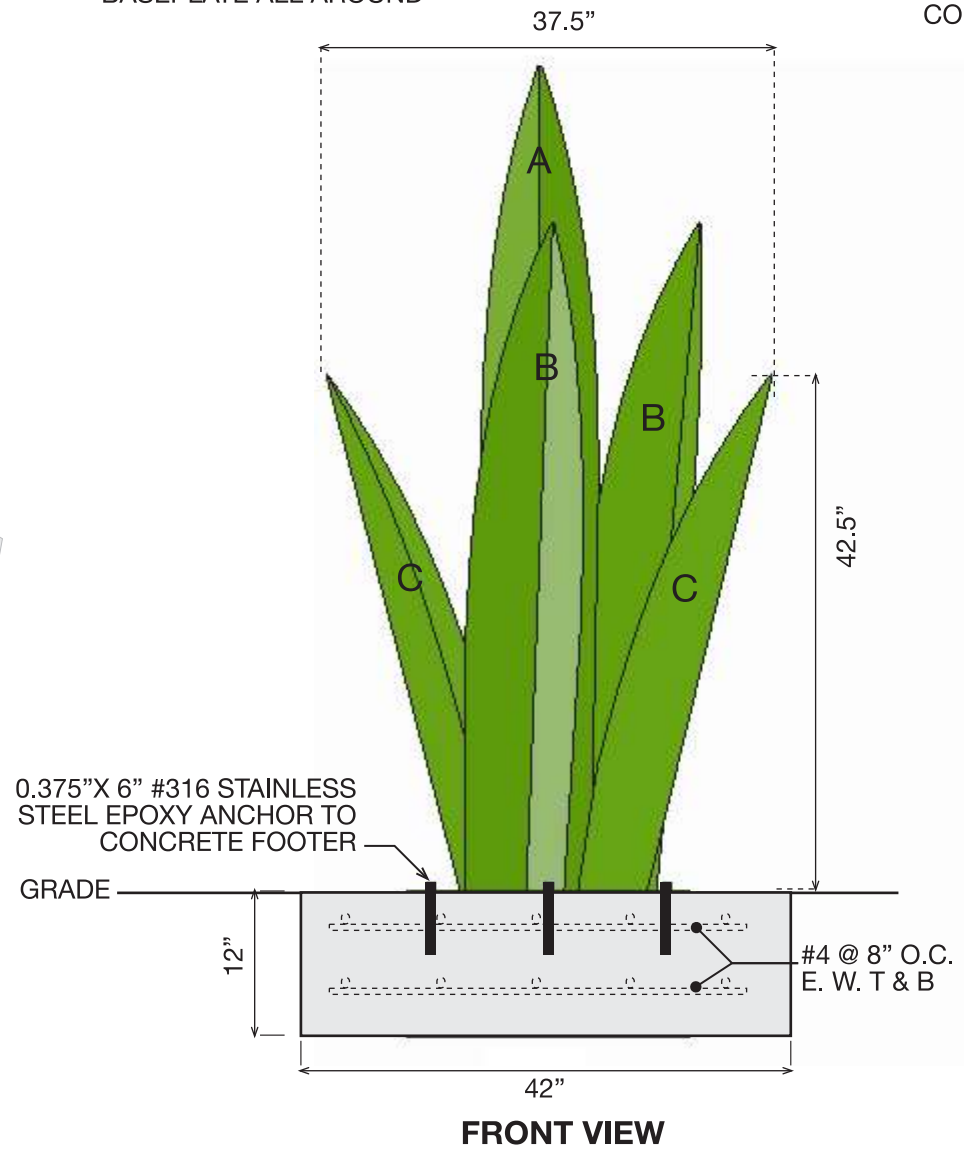
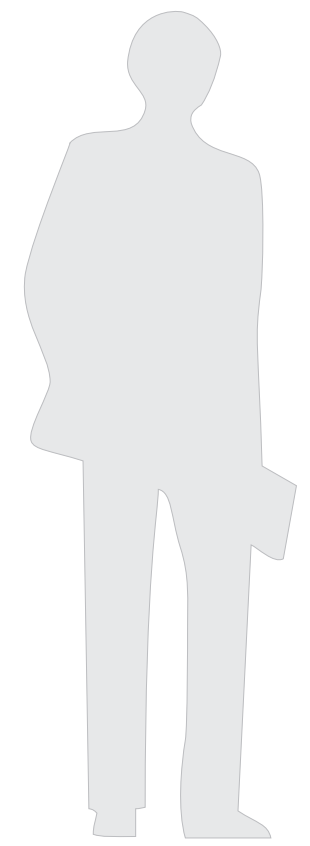
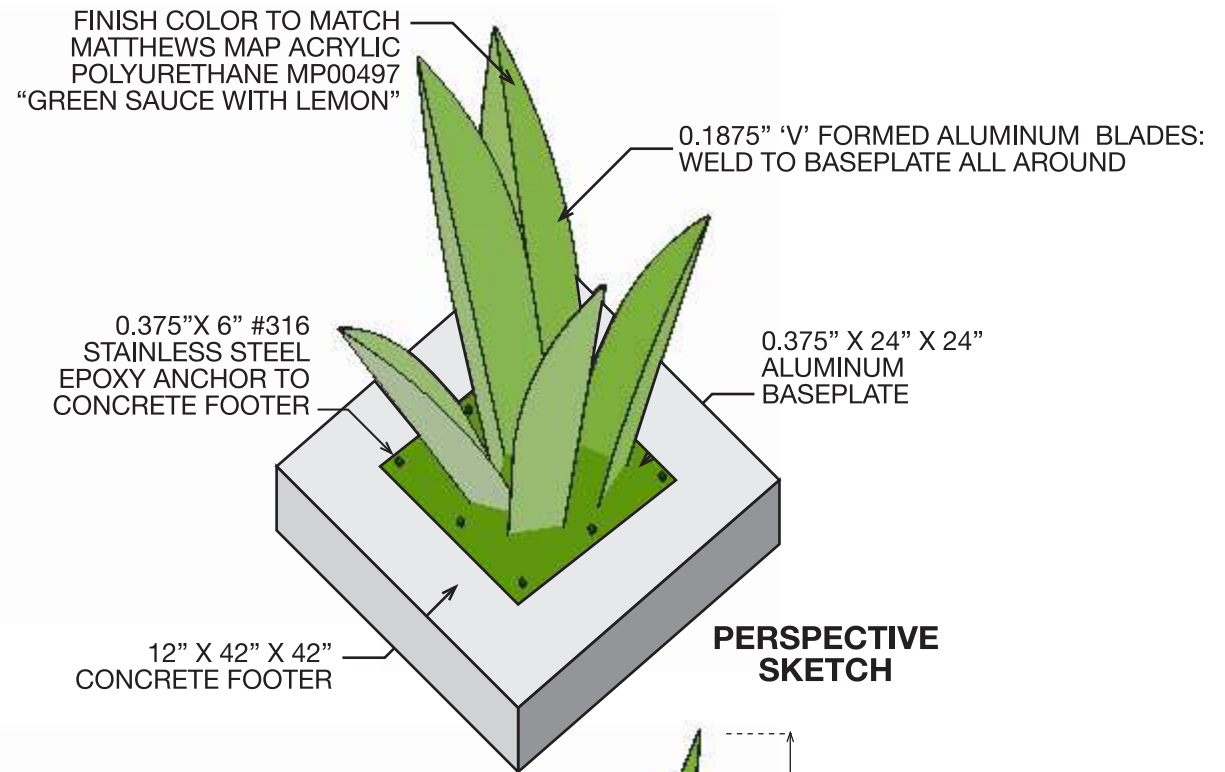
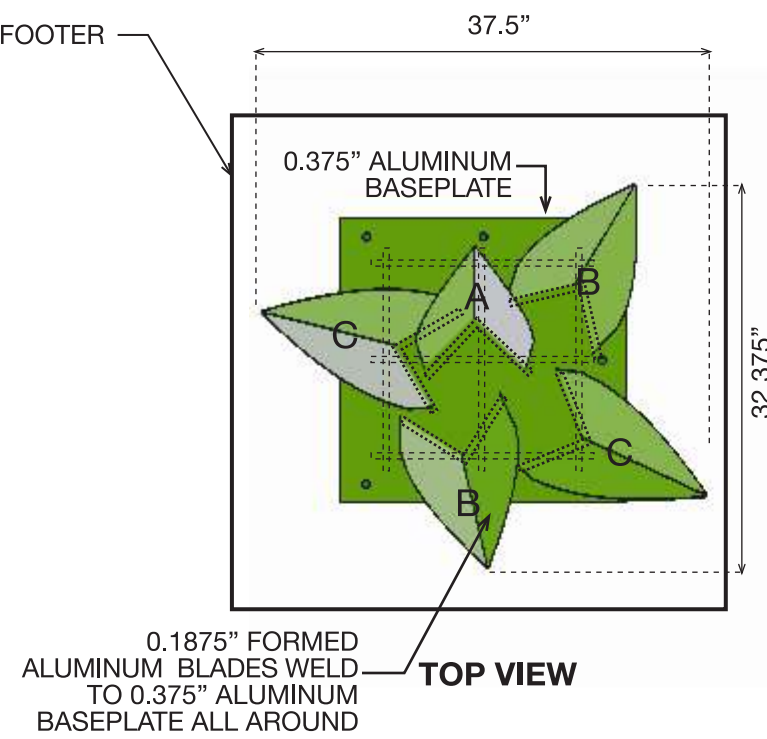
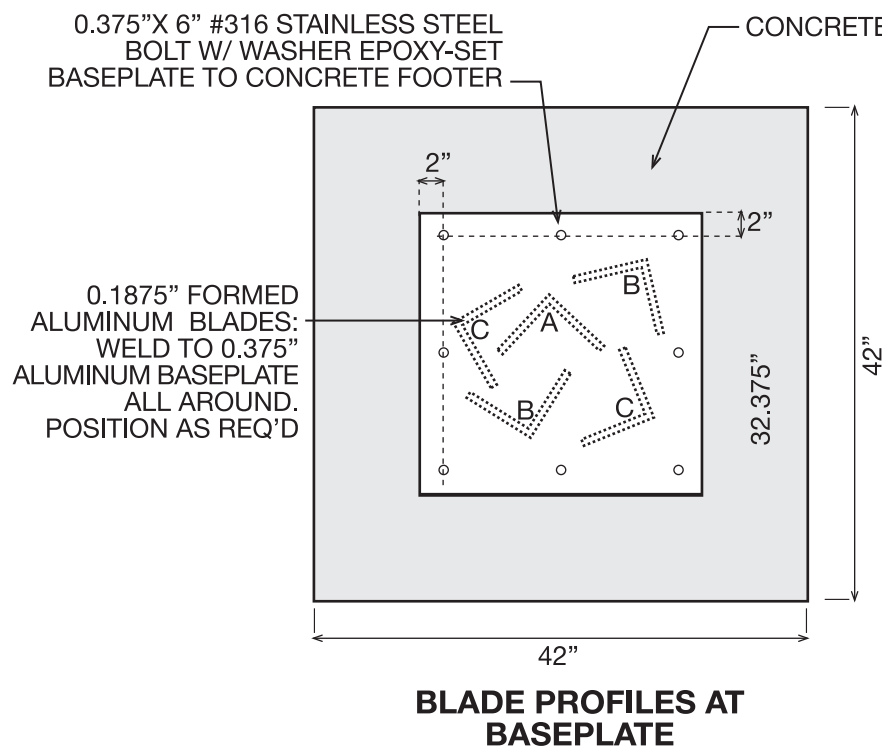

SPROUT CLUSTER TYPICAL DETAILS

WGI
WGInc.com

2035 VISTA PARKWAY
WEST PALM BEACH, FL 33411
OFFICE - 561.687.2220
WGINC.COM
WGI PROJECT NUMBER 10800.00

ENGINEER OF RECORD:
CHRISTOPHER B. LAFORTE
FLORIDA P.E. LICENSE NO.: 76797

DATE:

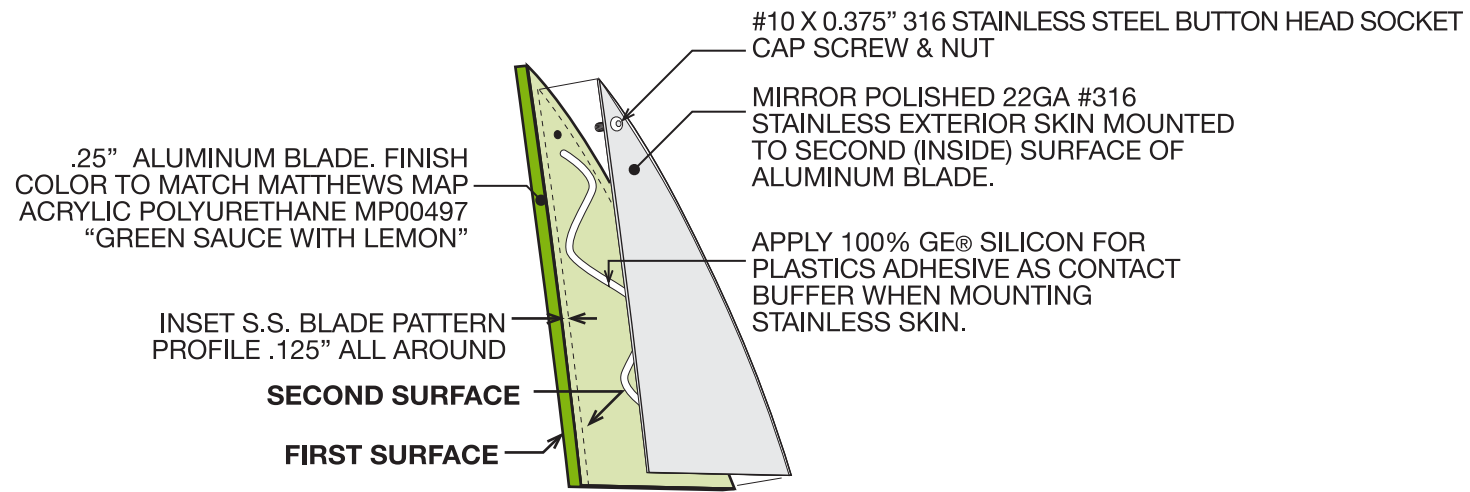

BOND-OVER DETAIL SKETCH

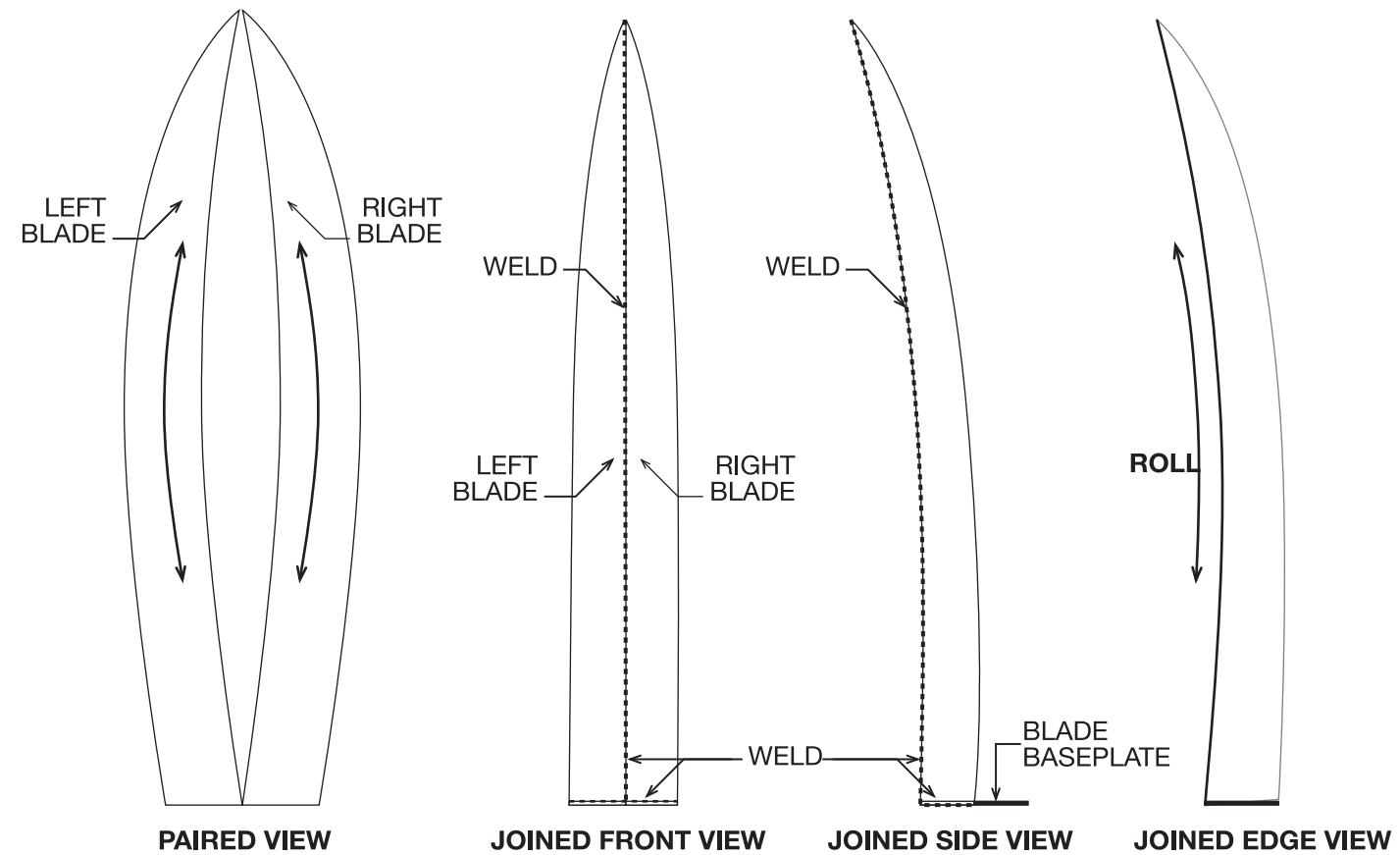

TYPICAL BLADE DETAIL

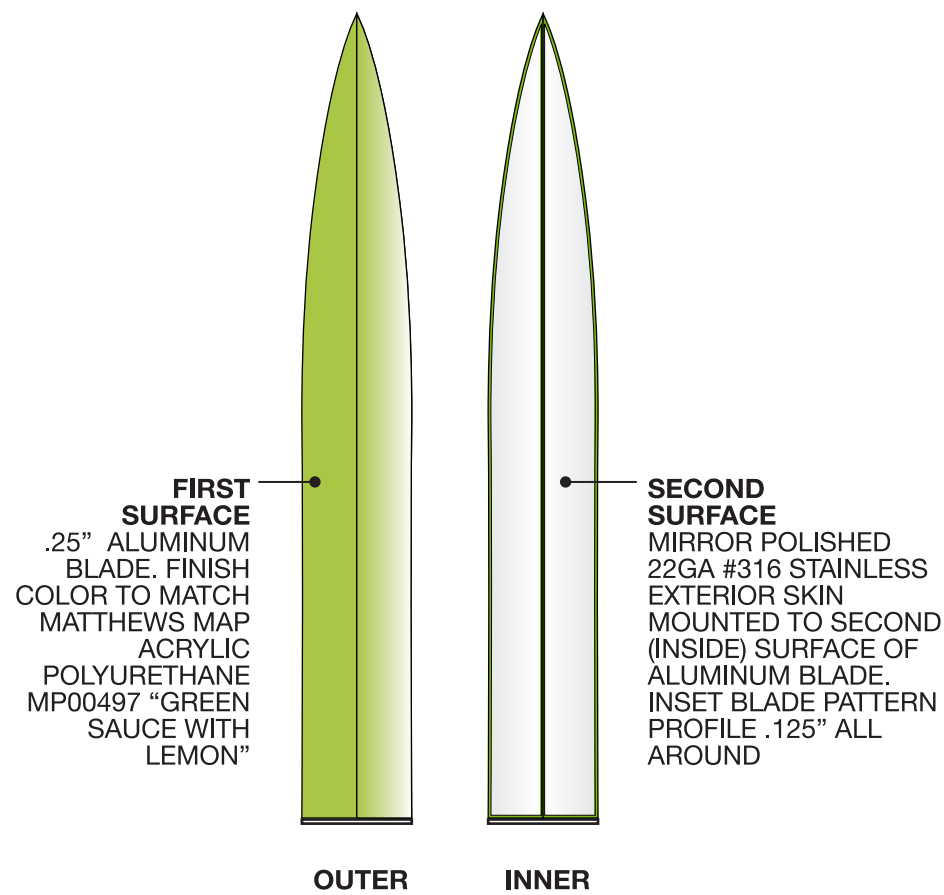

TYPICAL FORMED BLADE

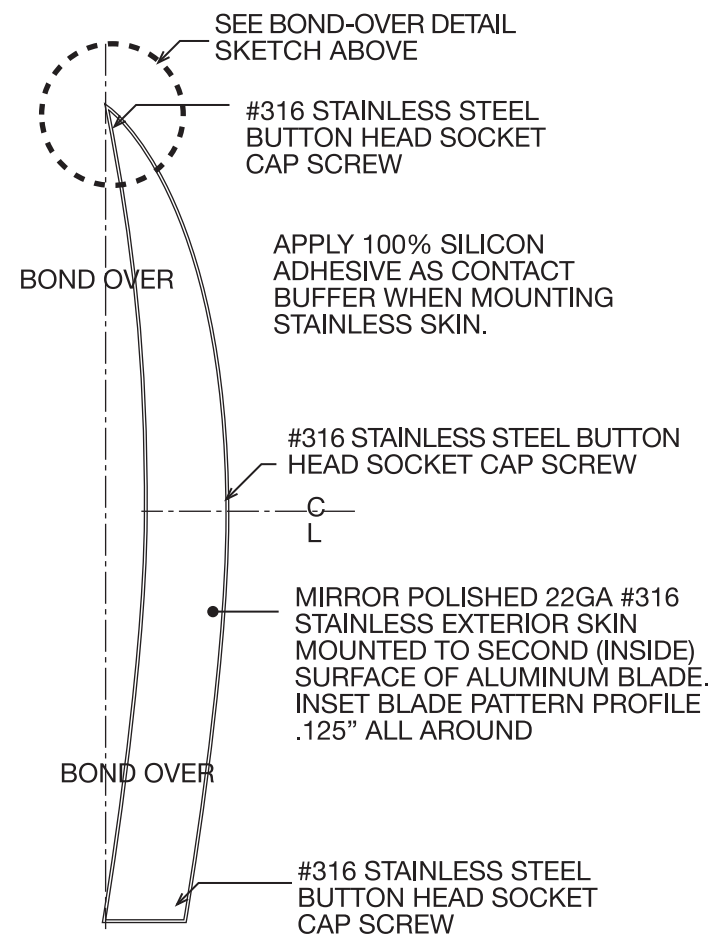

SECOND SURFACE BLADE DETAIL

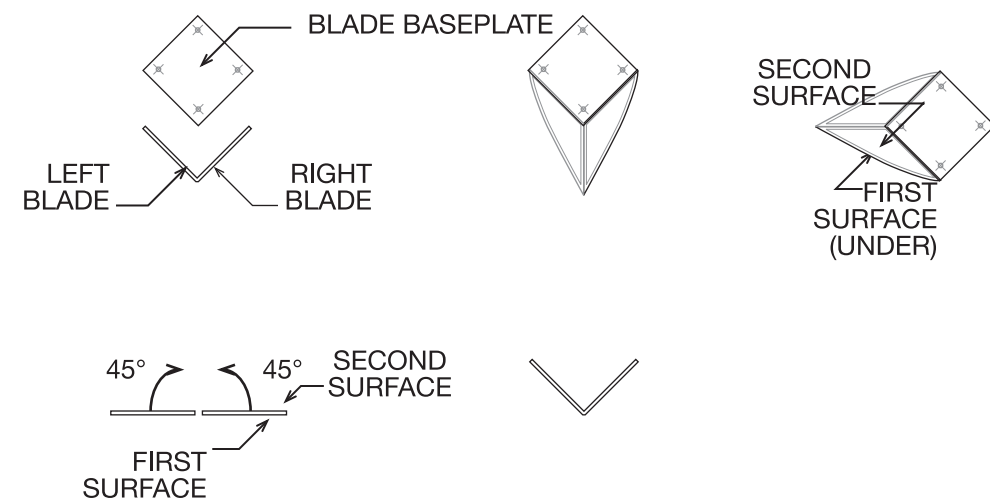

TOP VIEWS



2035 VISTA PARKWAY
WEST PALM BEACH, FL 33411
OFFICE - 561.687.2220
WGINC.COM
WGI PROJECT NUMBER 10800.00

ENGINEER OF RECORD:
CHRISTOPHER B. LAFORTE
FLORIDA P.E. LICENSE NO.: 76797

DATE:

PARENT BLADE FABRICATION DETAIL

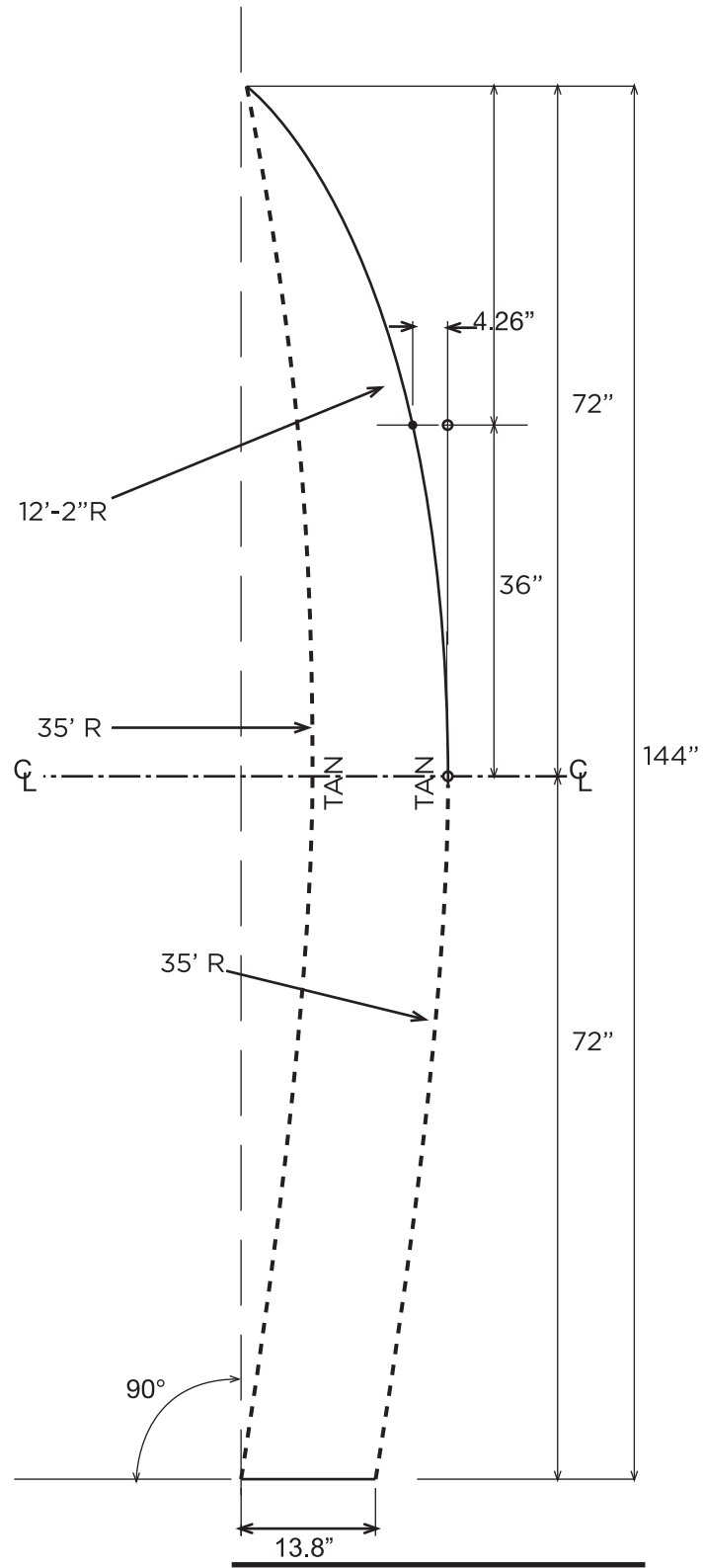

**BLADE TYPE A
FLAT PATTERN LAYOUT**

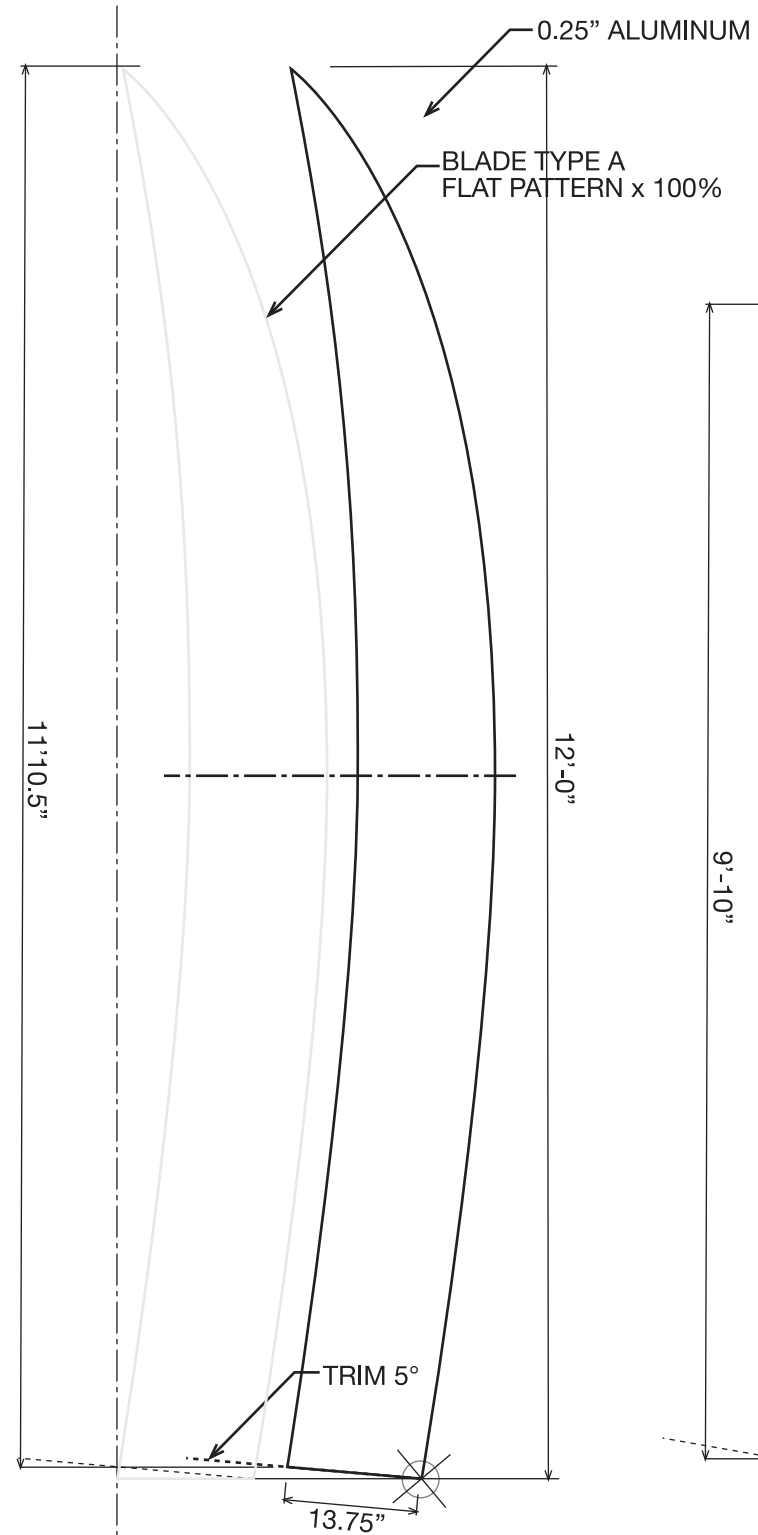

**BLADE TYPE A
CUT PATTERN LAYOUT**

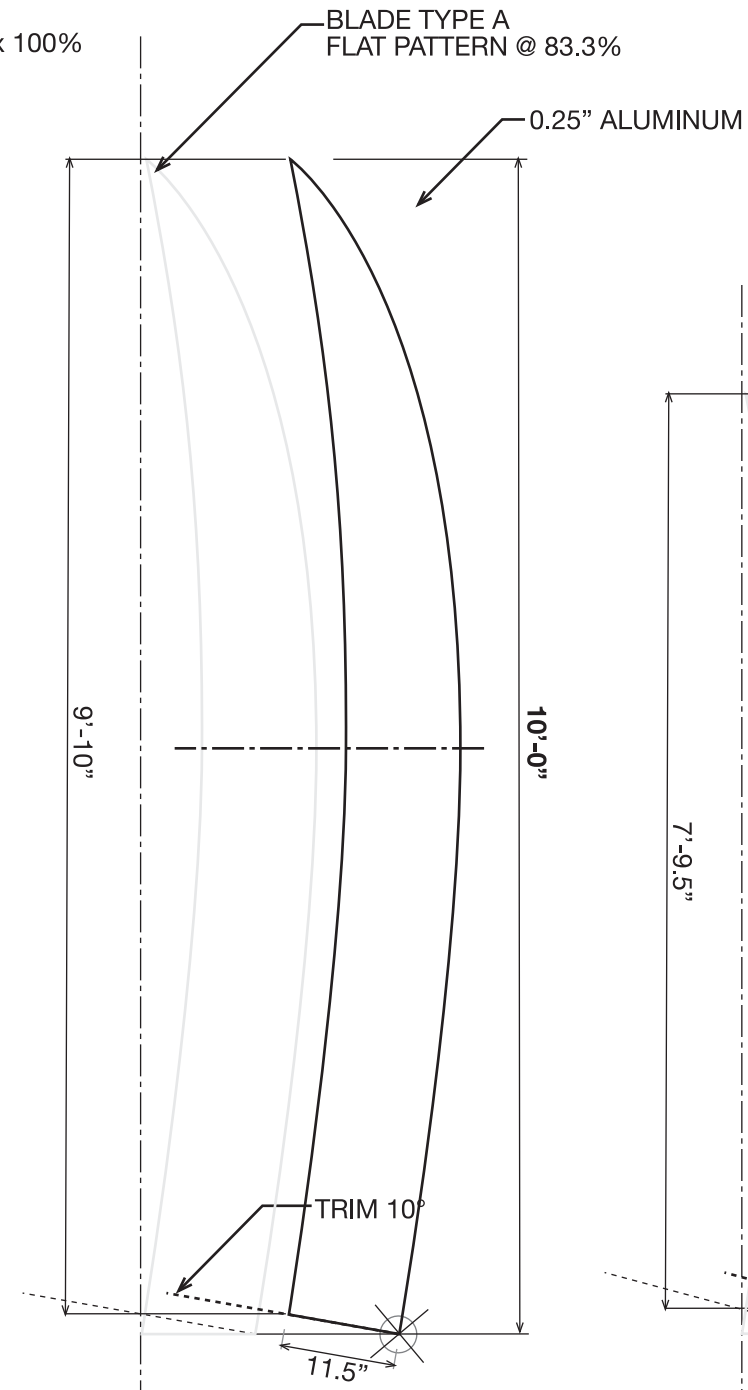

**BLADE TYPE B
CUT PATTERN LAYOUT**

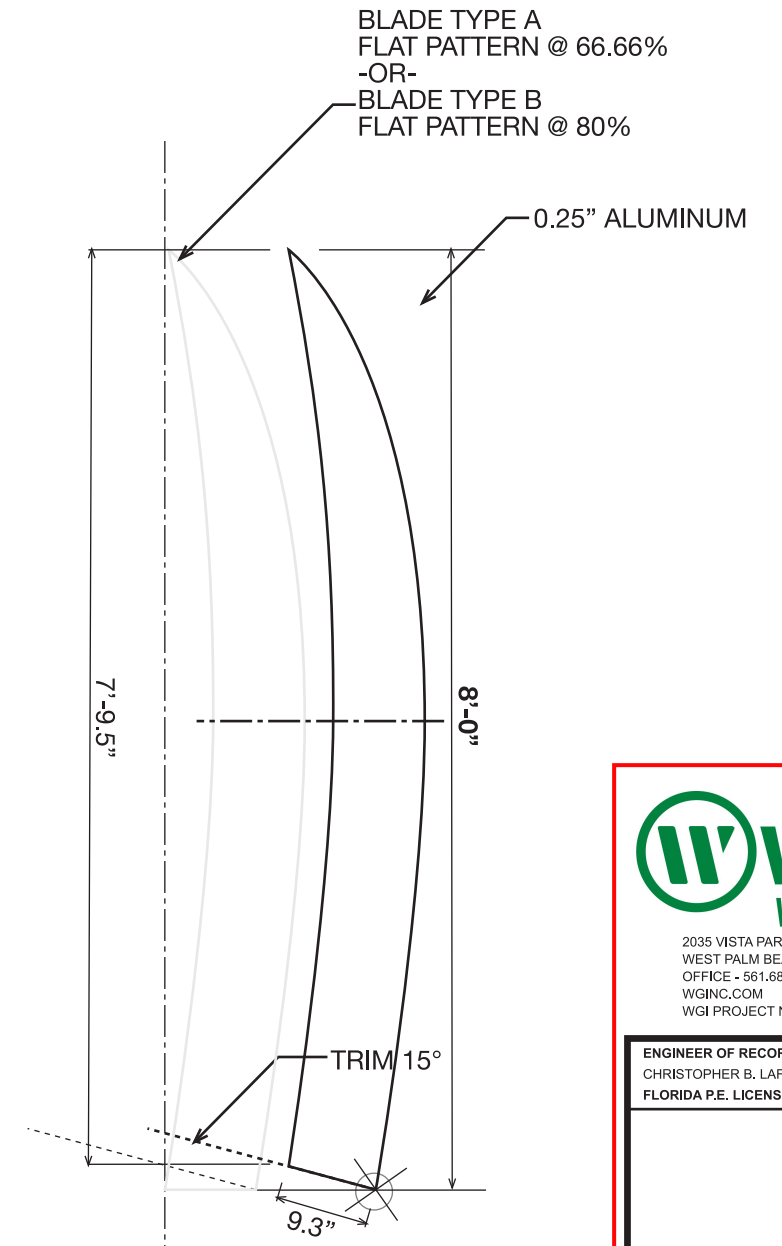

**BLADE TYPE C
CUT PATTERN LAYOUT**



2035 VISTA PARKWAY
WEST PALM BEACH, FL 33411
OFFICE - 561.687.2220
WGINC.COM
WGI PROJECT NUMBER 10800.00

ENGINEER OF RECORD:
CHRISTOPHER B. LAFORTE
FLORIDA P.E. LICENSE NO.: 76797

DATE:

PARENT BLADE TYPE A, B & C CUT PATTERN DETAILS

Ladybug Hideaway 10 of 15

WYLDER - Art In Public Places

City of Port St. Lucie, Florida 62

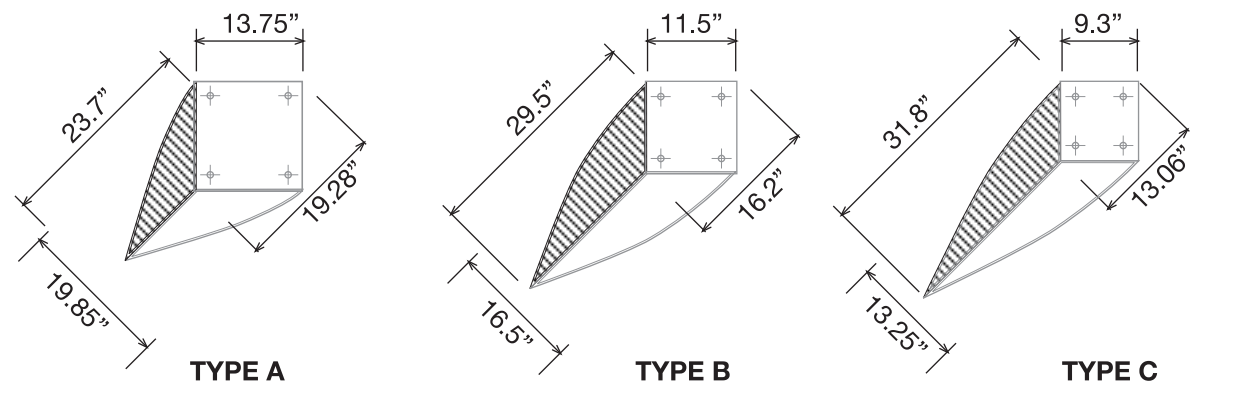

BLADE TYPE A, B, & C - PLAN VIEWS

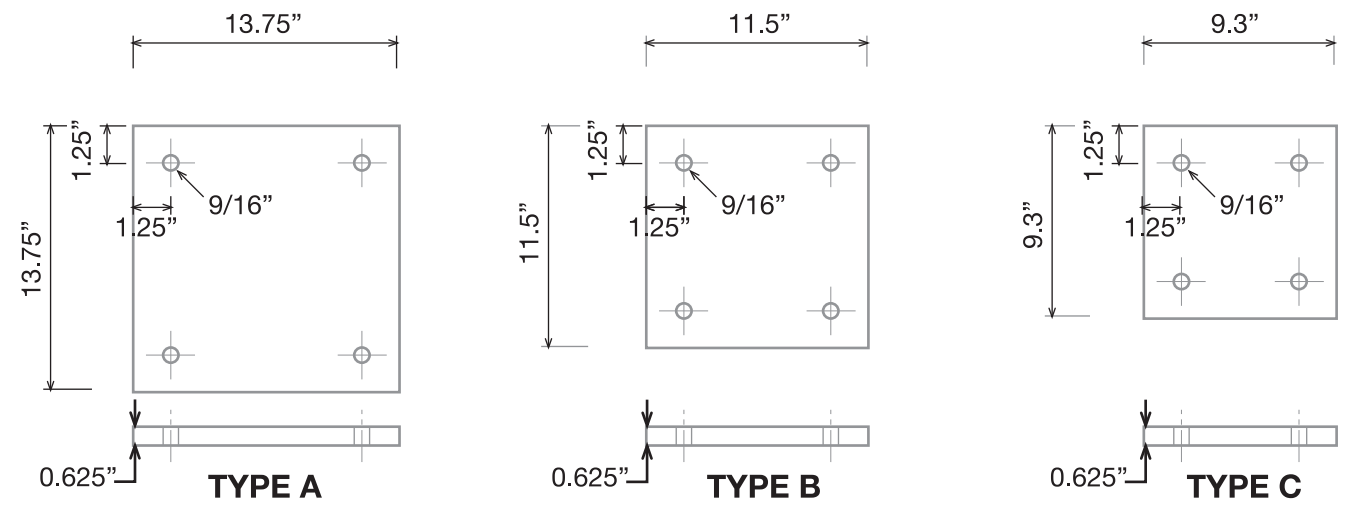

BLADE TYPE A, B, & C - ALUMINUM BASEPLATE DETAILS

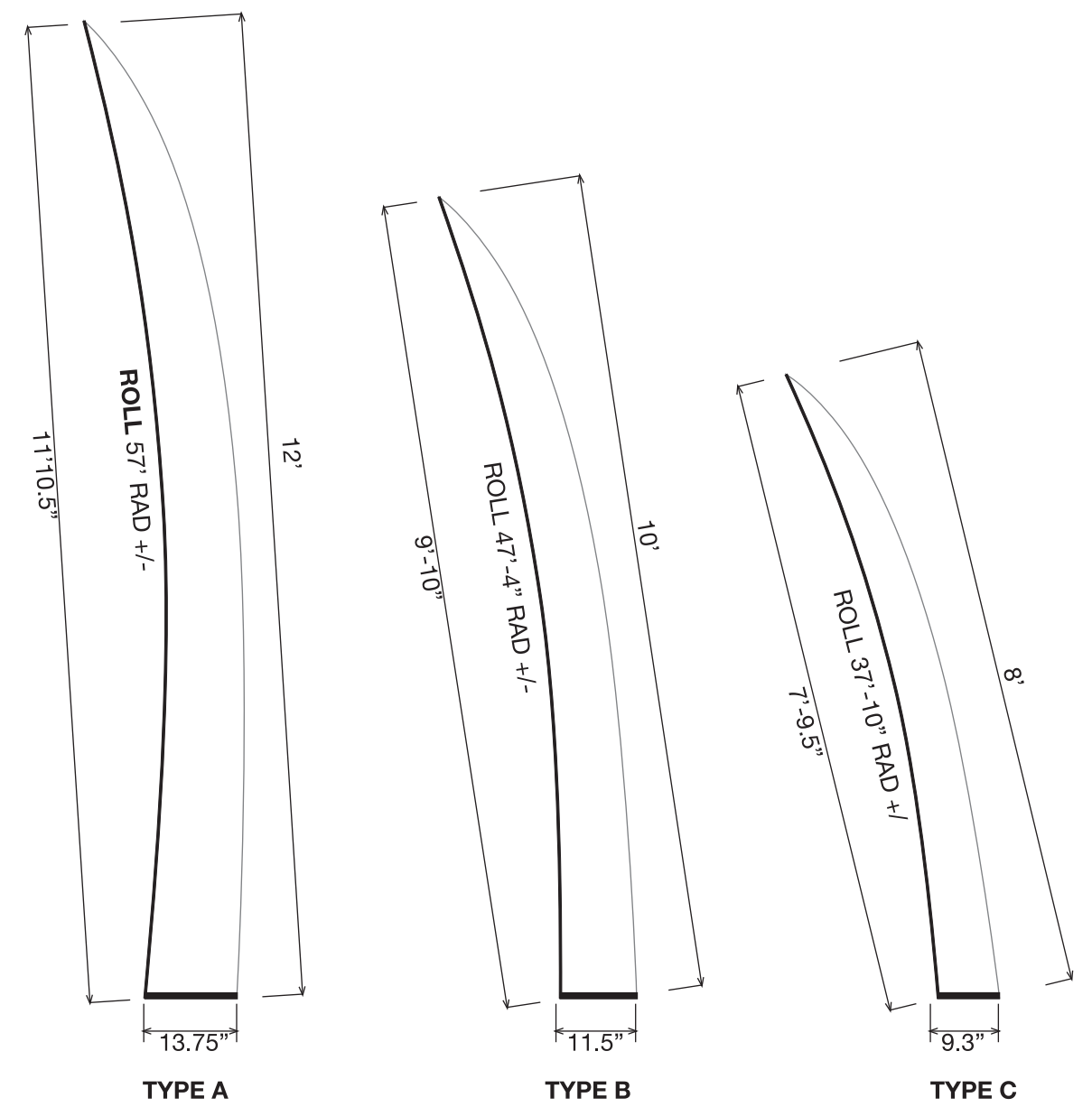

FORMED BLADES - SECTION ELEVATION

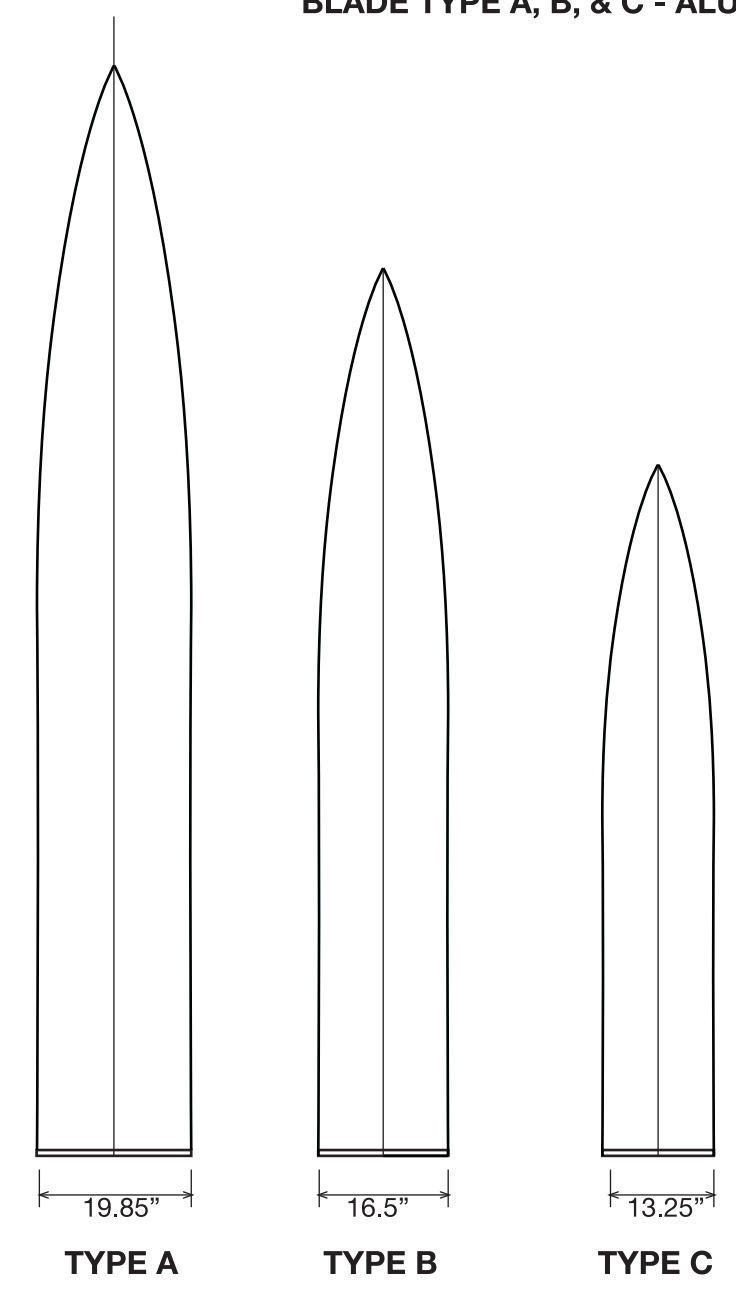

FORMED BLADES FRONT/BACK VIEWS

WGI
WGInc.com

2035 VISTA PARKWAY
WEST PALM BEACH, FL 33411
OFFICE - 561.687.2220
WGINC.COM
WGI PROJECT NUMBER 10800.00

ENGINEER OF RECORD:
CHRISTOPHER B. LAFORTE
FLORIDA P.E. LICENSE NO.: 76797

DATE:

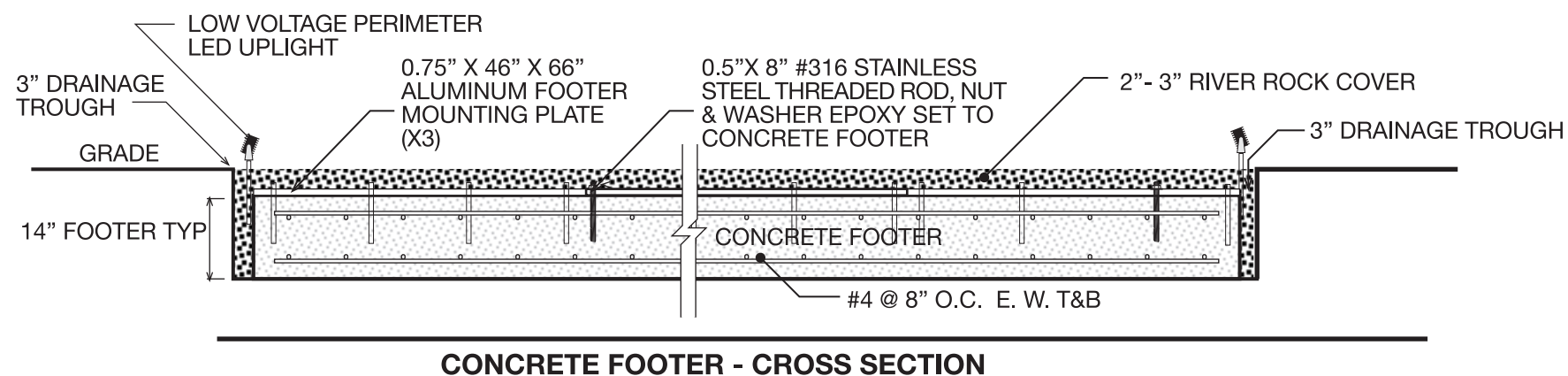
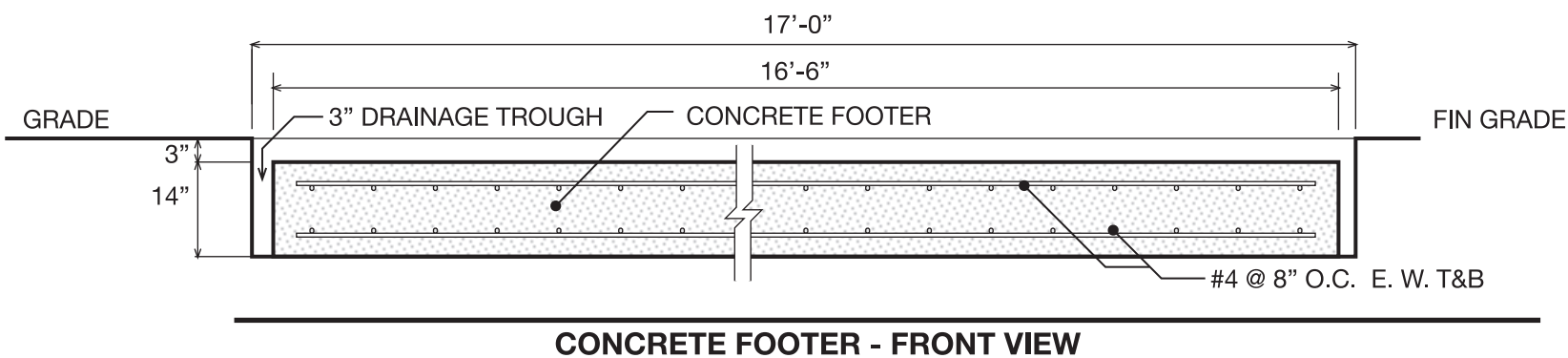
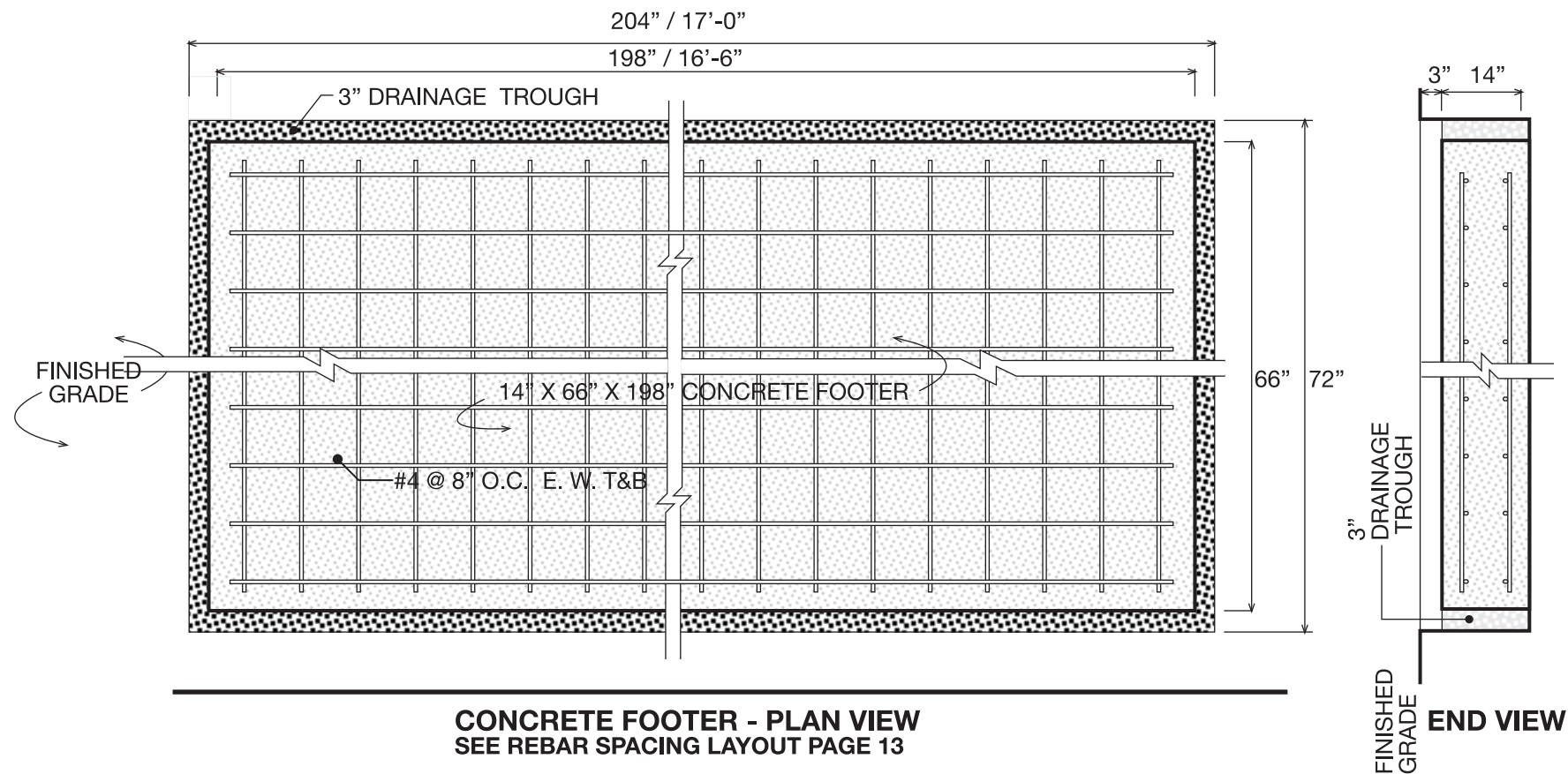

GENERAL NOTES:

- 1 - Fabricate all aluminum in accordance with the Aluminum Association Aluminum Design Manual, latest edition (ADM-20)
- 2 - All aluminum material shall be 6061-T6 (U.O.N.)
- 3 - All fasteners shall be grade 316 stainless steel w/ neoprene washers installed between nuts and aluminum plates.
- 4 - All welds must be 3/16" fillet minimum and in accordance with ANSI/AWS D.1.2/D1/2M gas metal arc welding (gmaw) process by experienced operators
- 5 - Coat all aluminum in contact with concrete and other dissimilar metals with bitumastic paint on the contact surface or 30# felt paper.
- 6 - All structures designed in accordance with Section 16 of the Florida Building Code 8th Edition - ASCE 7-22
- 7 - Artwork designed for 150 mph (3 second gust) ultimate wind speed, Risk Category 1, Exposure C,
- 8 - Assumed soil bearing pressure = 2500 psf.
- 9 - Compact subgrade to 95% of AASHTO T-180.
- 10 - All concrete shall be normal weight concrete (145 pcf) and strength shall meet $F_c' = 3000$ psi minimum 28 day compressive strength.
- 11 - Concrete work shall be in accordance with ACI 318, latest edition.
- 12 - All reinforcement shall be ASTM A615 Grade 60, deformed bars.
- 13 - Concrete reinforcement clear cover at minimum shall be:
 - 2" for formed concrete below grade
 - 3" for unformed concrete below grade
- 14 - Post-installed adhesive anchors shall use one of the following or engineer approved equivalent:
 - Ultrabond HS-1CC (ICC ES ESR-4094) By Adhesive Technology
 - Hilti HIT-RE 500 V3 (ICC ES ESR-3814) By Hilti
 - Set-XP (ICC ES ESR-2508) By Simpson Strongtie
 - Pure 110+ (ICC ES ESR-3298) By Dewalt



2035 VISTA PARKWAY
WEST PALM BEACH, FL 33411
OFFICE - 561.687.2220
WGINC.COM
WGI PROJECT NUMBER 10800.00

ENGINEER OF RECORD:
CHRISTOPHER B. LAFORTE
FLORIDA P.E. LICENSE NO.: 76797

DATE:



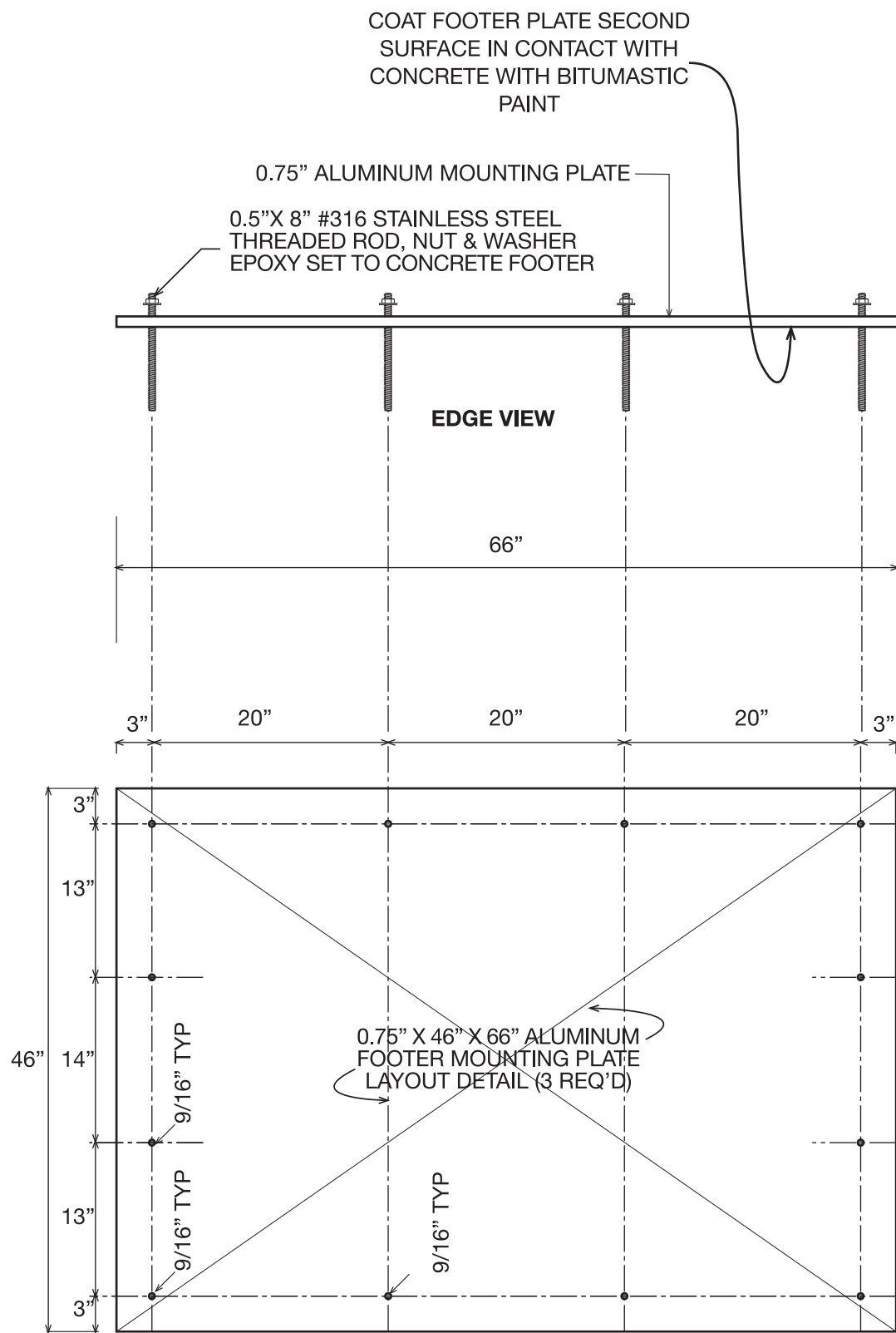

TYPICAL FOOTER MOUNTING PLATE
3 REQ'D PER FOOTER

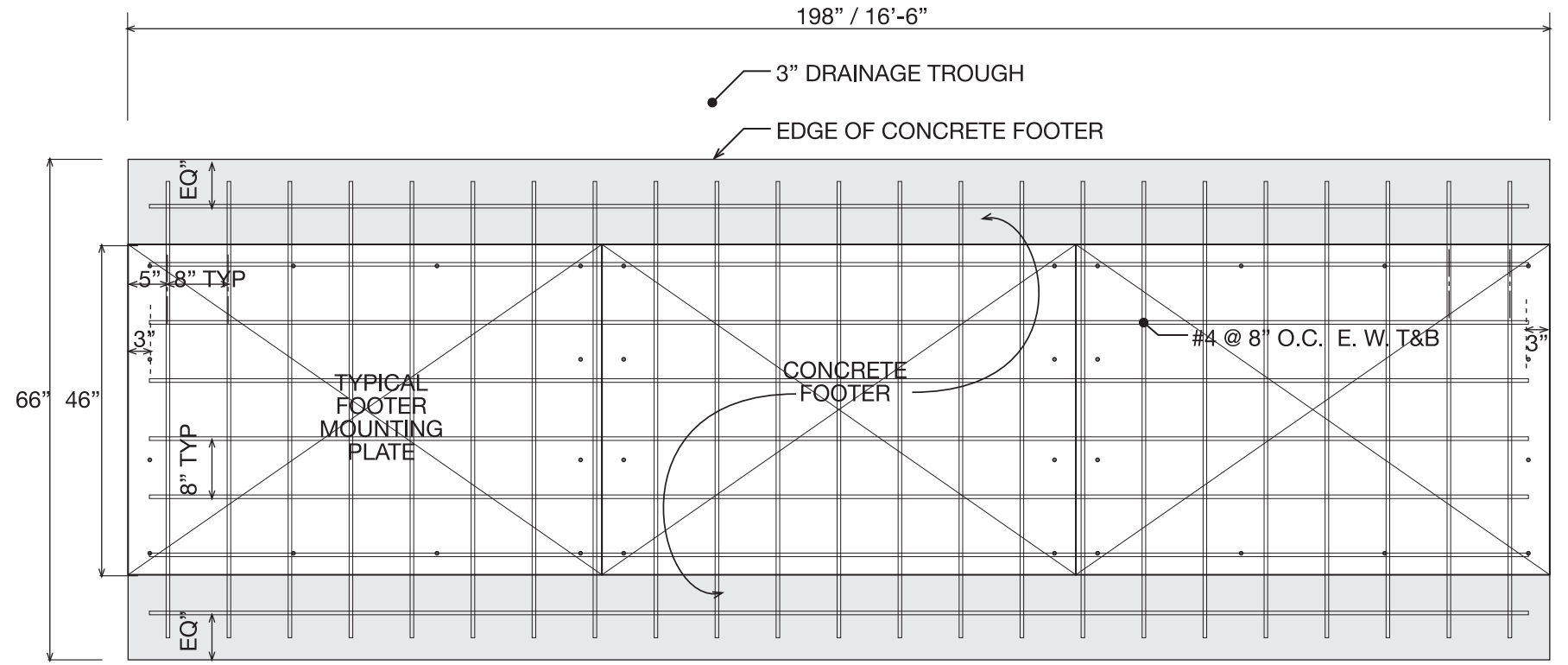

FOOTER MOUNTING PLATES ON CONCRETE FOOTER & REBAR SPACING LAYOUT

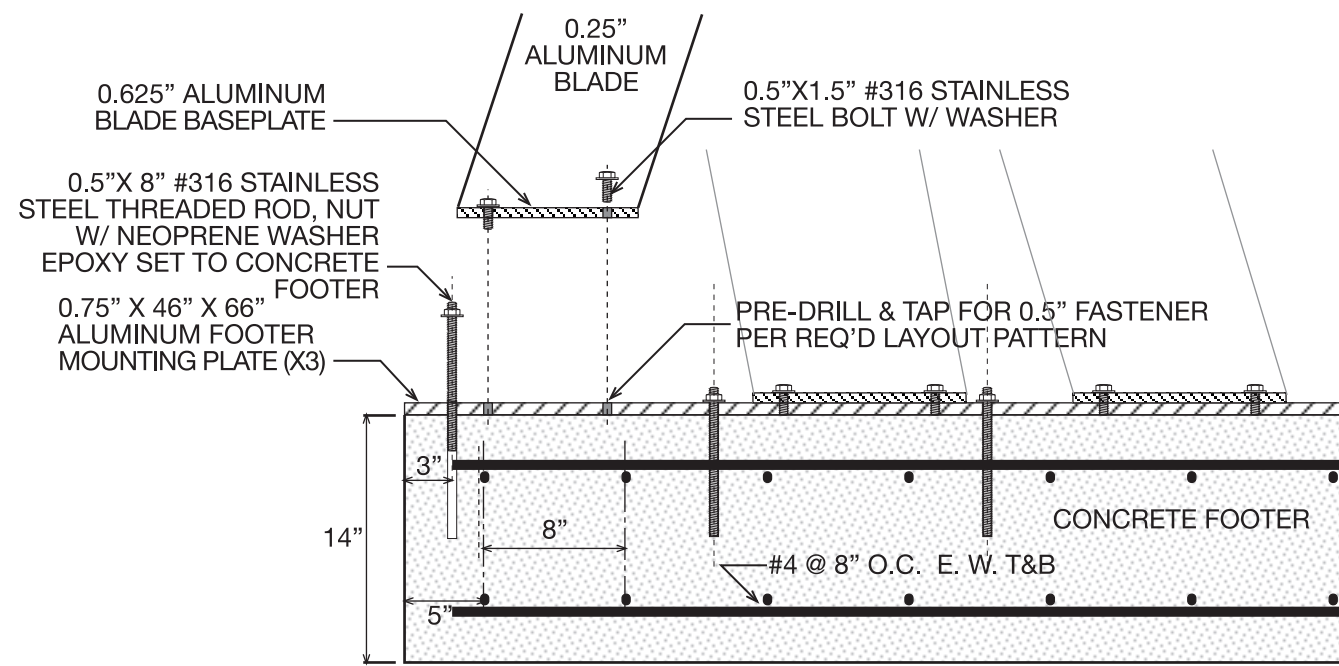
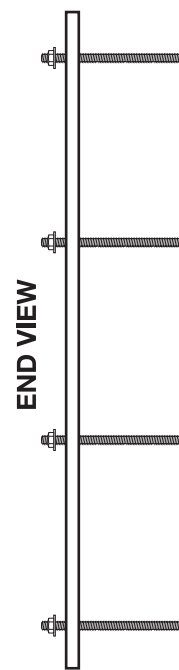

EXPLODED TYPICAL SECTION DETAIL

WGI
WGInc.com

2035 VISTA PARKWAY
WEST PALM BEACH, FL 33411
OFFICE - 561.687.2220
WGINC.COM
WGI PROJECT NUMBER 10800.00

ENGINEER OF RECORD:
CHRISTOPHER B. LAFORTE
FLORIDA P.E. LICENSE NO.: 76797

DATE:

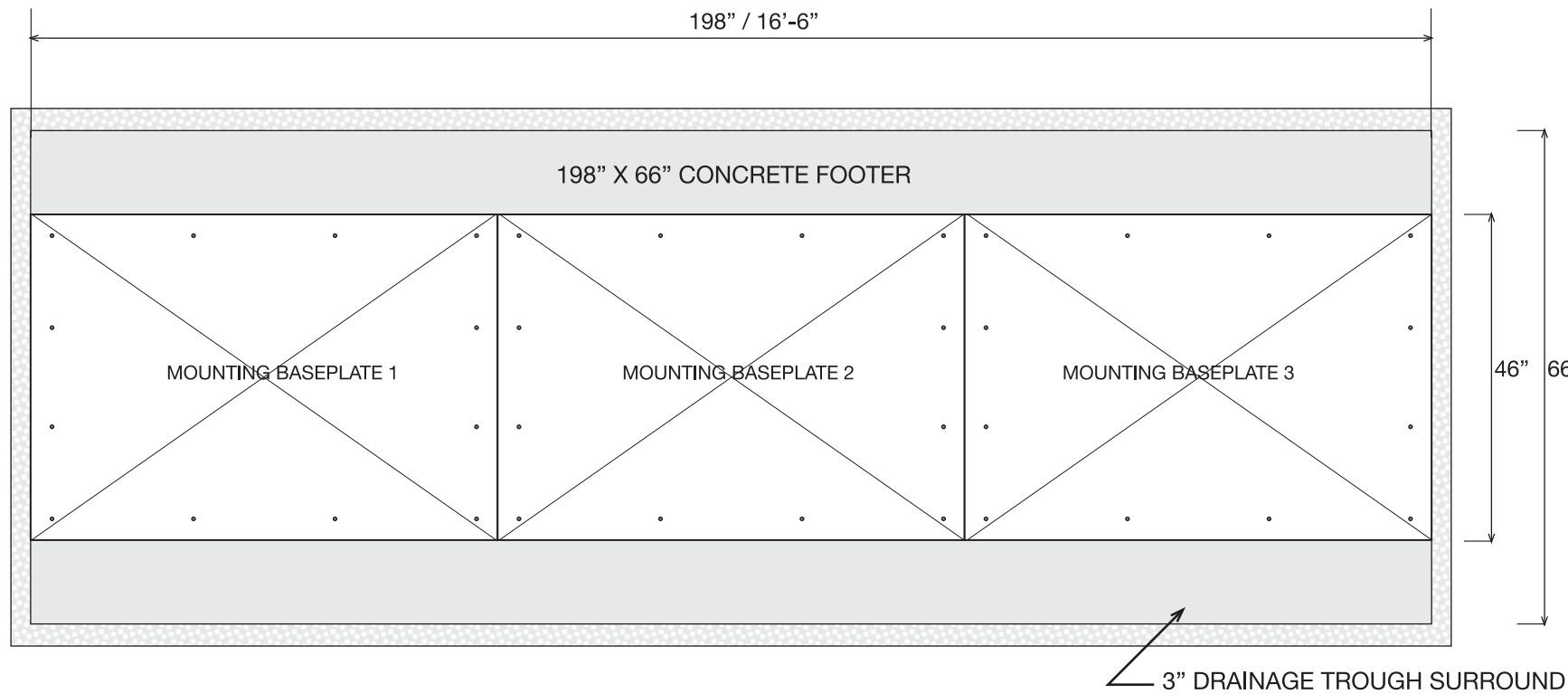

FOOTER MOUNTING PLATES - PLAN VIEW

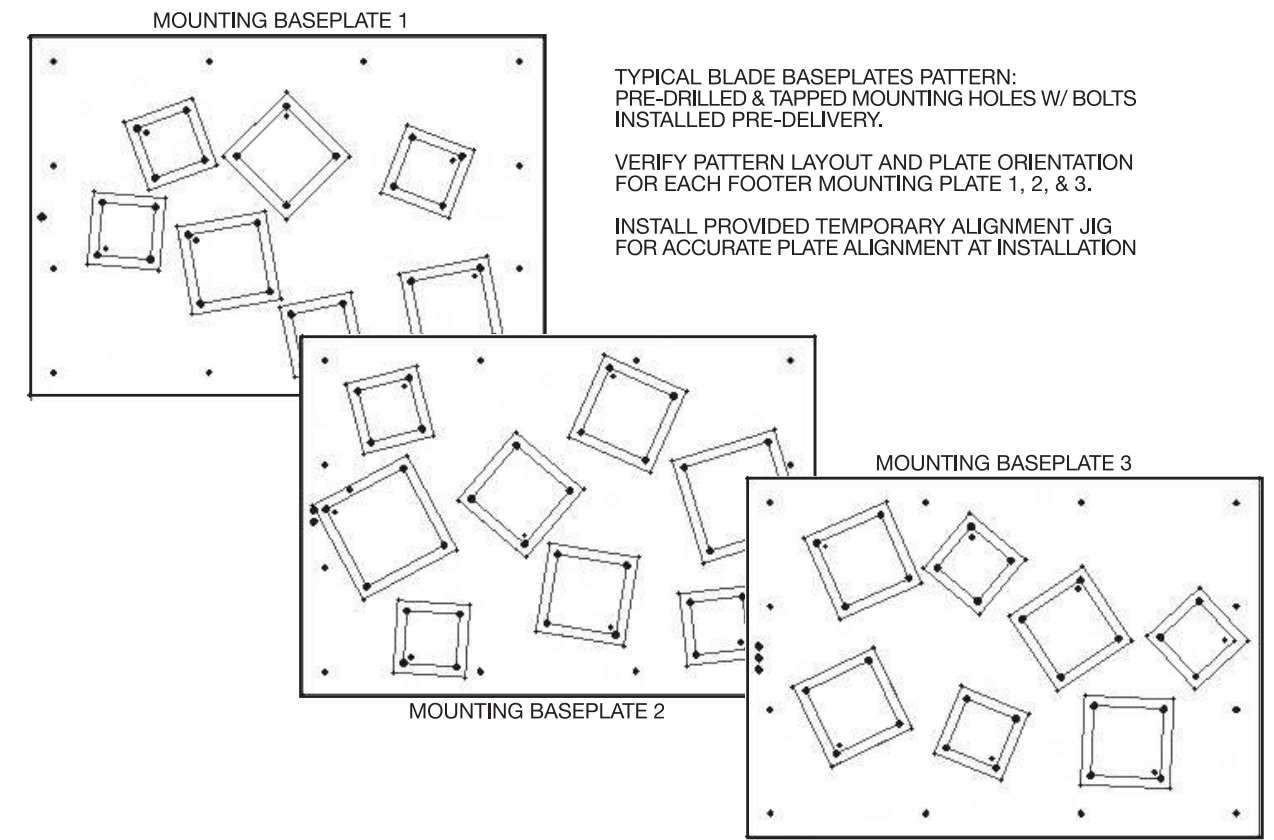

FOOTER MOUNTING PLATES - HOLE PATTERNS

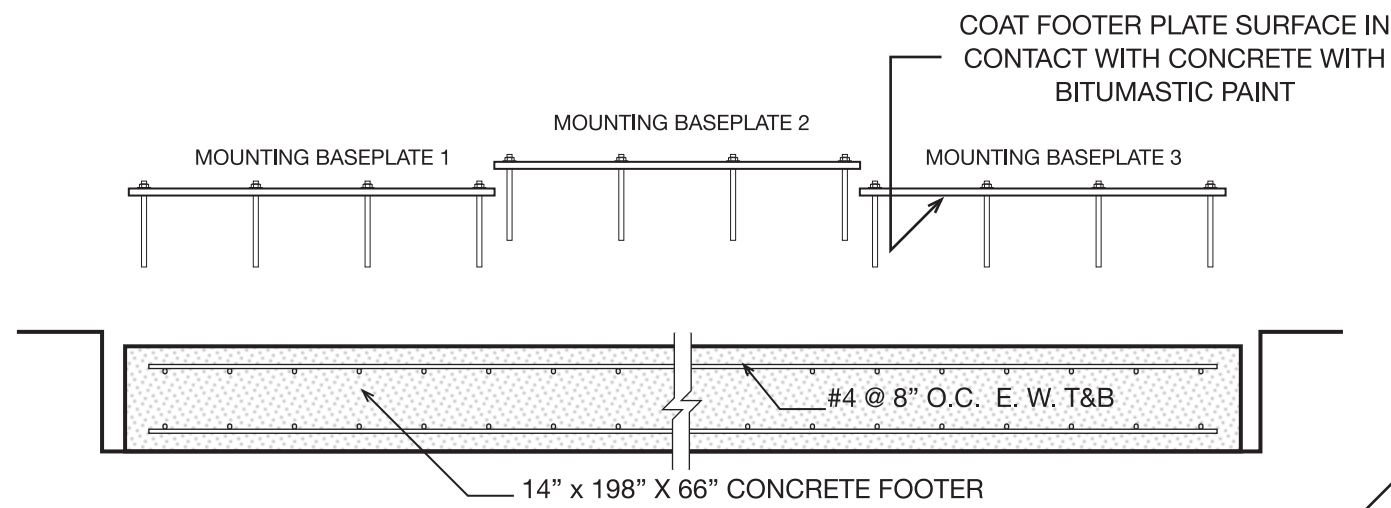

CONCRETE FOOTER FRONT VIEW

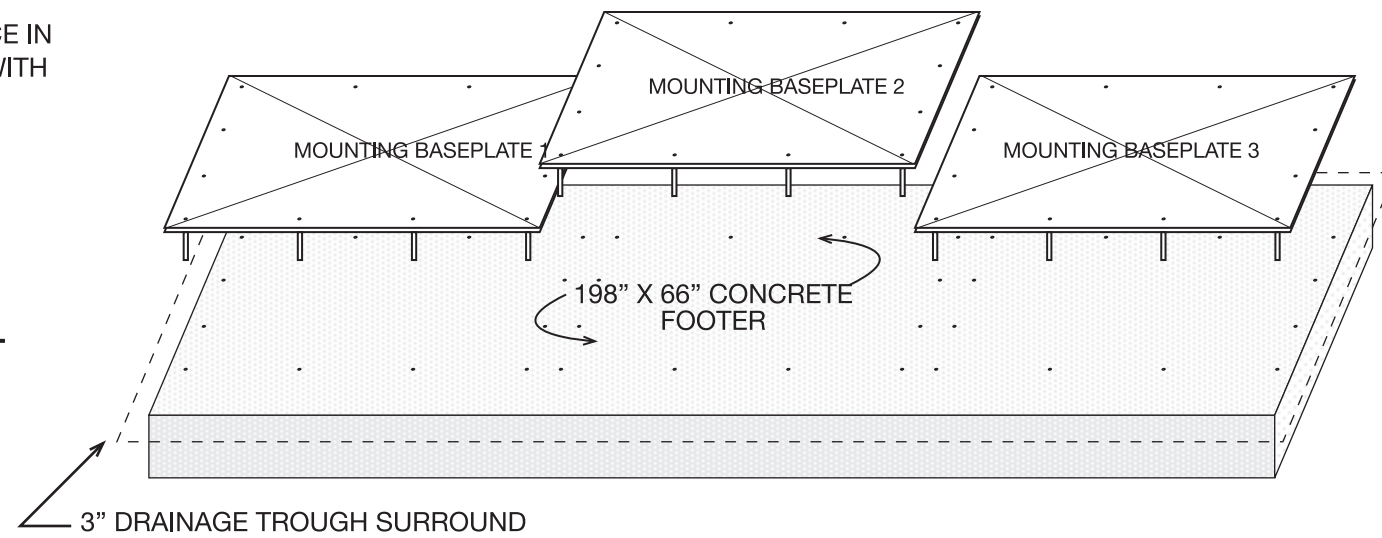

FOOTER & MOUNTING PLATE PERSPECTIVE SKETCH

WGI
WGInc.com

2035 VISTA PARKWAY
WEST PALM BEACH, FL 33411
OFFICE - 561.687.2220
WGINC.COM
WGI PROJECT NUMBER 10800.00

ENGINEER OF RECORD:
CHRISTOPHER B. LAFORTE
FLORIDA P.E. LICENSE NO.: 76797

DATE:

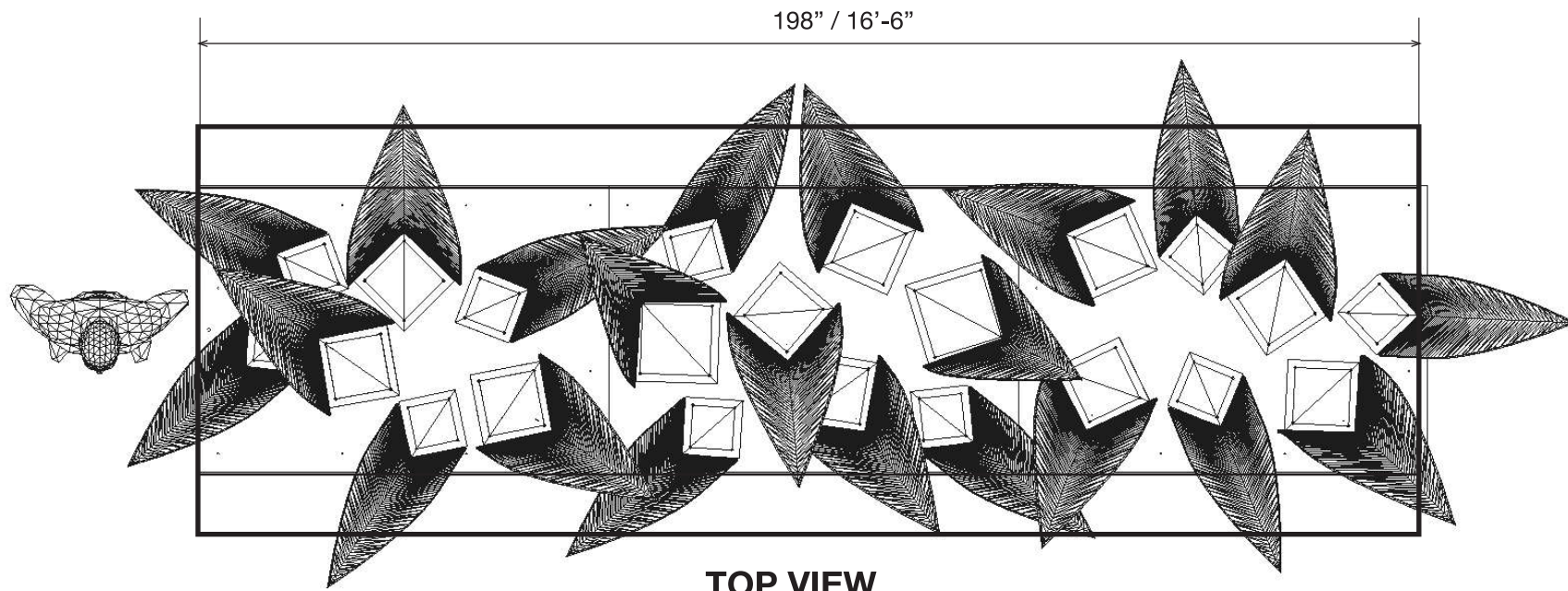

TOP VIEW

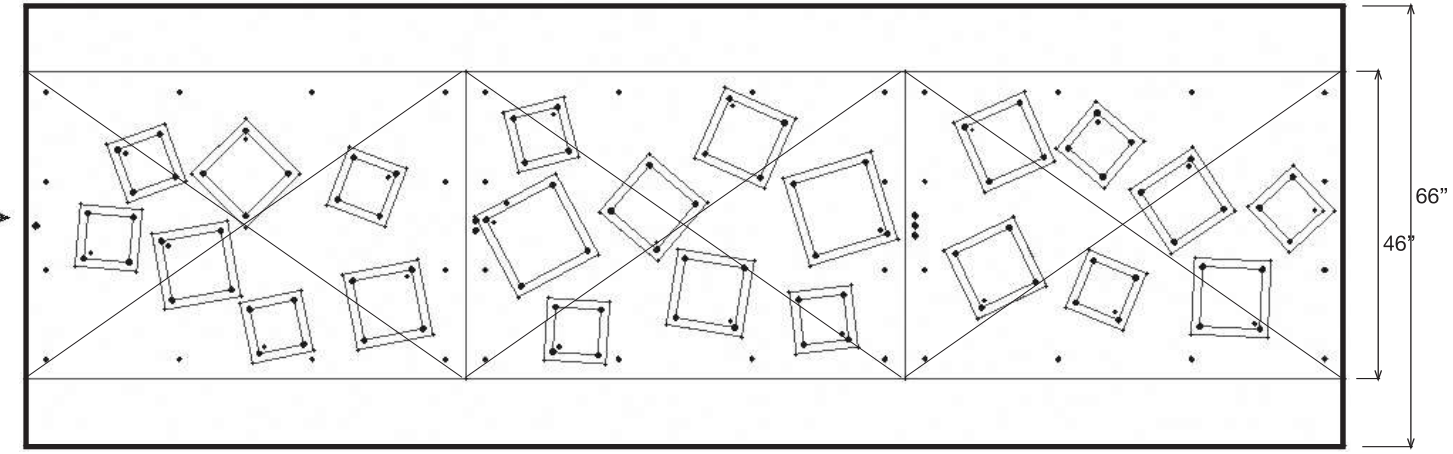

LAYOUT VIEW

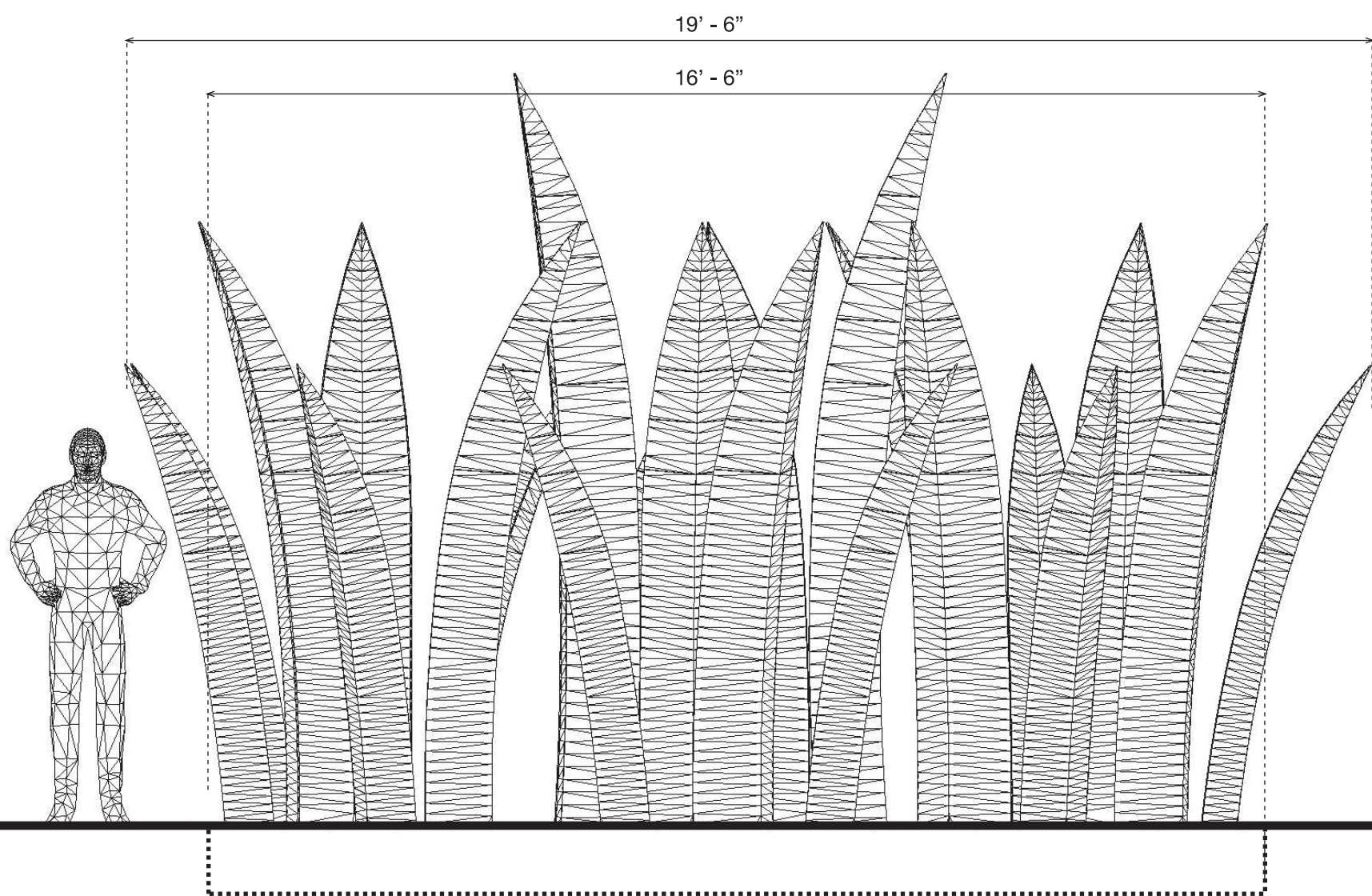

FRONT VIEW

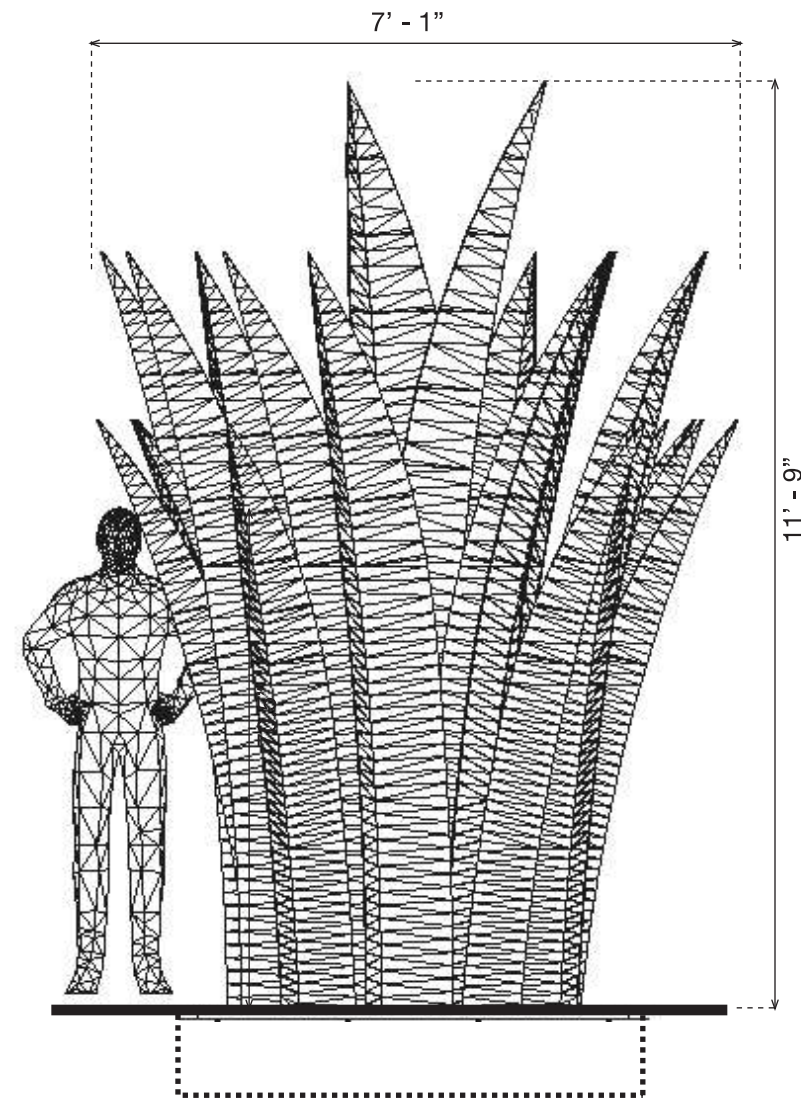

END VIEW

WGI
WGInc.com

2035 VISTA PARKWAY
WEST PALM BEACH, FL 33411
OFFICE - 561.687.2220
WGINC.COM
WGI PROJECT NUMBER 10800.00

ENGINEER OF RECORD:
CHRISTOPHER B. LAFORTE
FLORIDA P.E. LICENSE NO.: 76797

DATE:

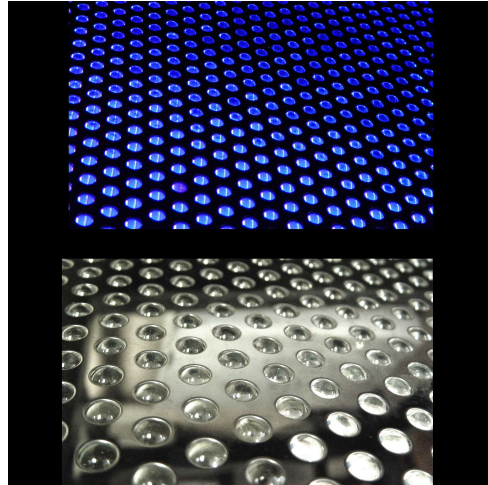

The Hunt For Cool Culture's newest buzzword

Cool is fast becoming the new frontier in a niche-mad world, which has major implications for all culture and consumer industries - from marketing, advertising and media, right through to retail and hospitality. The Cool Age is here.

Cool has become a concept denoting a kind of elusive X-factor that makes something exceptional,. Individual. Covetable. Inspiring. Independent. Thoughtful. Limited. Pioneering. Exclusive. Innovative. Original.

Cool has become shorthand for anything "interesting" used by everyone - from Boomers through to Generation Y.

Whatever its manifestation, cool gives a brand, person, product, place or service a supernatural power to rise above the noise. To stand out in an ocean of "stuff" and make people remark to themselves:

"I want that."

"I love that."

"I'm going to tell my friends about that."

Step into the Cool Age.



MTFULLER
FUNCTIONAL ARTS

⚡ mtfuller.id8@gmail.com

Art In Public Places

Environmental Graphics

3 Dimensional Built Objects

Extraordinary Ideation

5617074688



The Obelisk
2006
Palm Beach Gardens, FL

Standing over three stories high, *The Obelisk* proudly does its job day and night as a visual landmark. With a skin that has been perforated and filled with 89,998 clear glass marbles, this sentinel of mirror-polished stainless steel has every reason to stand tall. Housed inside are four DMX controllers to orchestrate a brilliant lightshow of colorful gradient changes throughout the night. With 1,152 clusters of energy efficient RGB LED bulbs capable of 12 million possible colors, *The Obelisk* stakes its claim as the most prominent place marker around. Color salad? Yes, please!

Since its mirror-polished surface reflects the surrounding sky, at times *The Obelisk* is anchored against it in great contrast while at others it will almost disappear. Whatever the conditions, *The Obelisk* is the ultimate contemporary translation of a classic monumental form.

Welcome to the Cool Age.

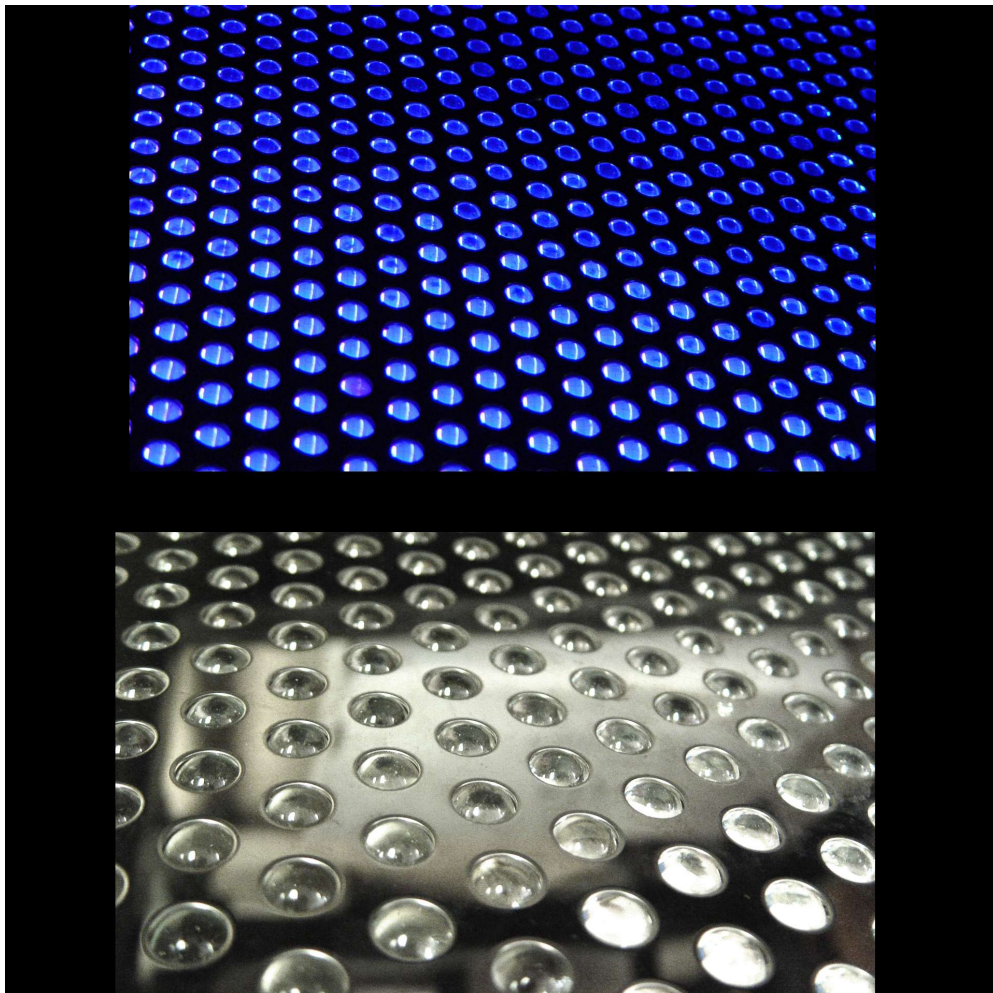

MTFULLER
FUNCTIONAL ARTS

⚡ mtfuller.id8@gmail.com

Art In Public Places

Environmental Graphics

3 Dimensional Built Objects

Extraordinary Ideation

5617074688



Magician's Birthday
2003
SunTrust Bank

A lone sentinel along a primary road, Magician's Birthday is designed to appear as orderly as the accounting in the bank behind it.

A departure from Fuller's bold use of applied color finishes, the contrasting materials of rusted cor-ten steel and bright aluminum on this installation emphasize the interplay of its geometry.

The stacked silver disks are a visual pun of Fuller's personal banking experience with a now defunct financial institution. From the side, it would appear that there were 7 coins. However, from the front much of the coin (the center) is actually missing. This was a metaphor for how he felt a chunk of his money always seemed to disappear while in the bank. Thank you, hidden service charges!

At times, art speaks quietly.

Welcome to the Cool Age.

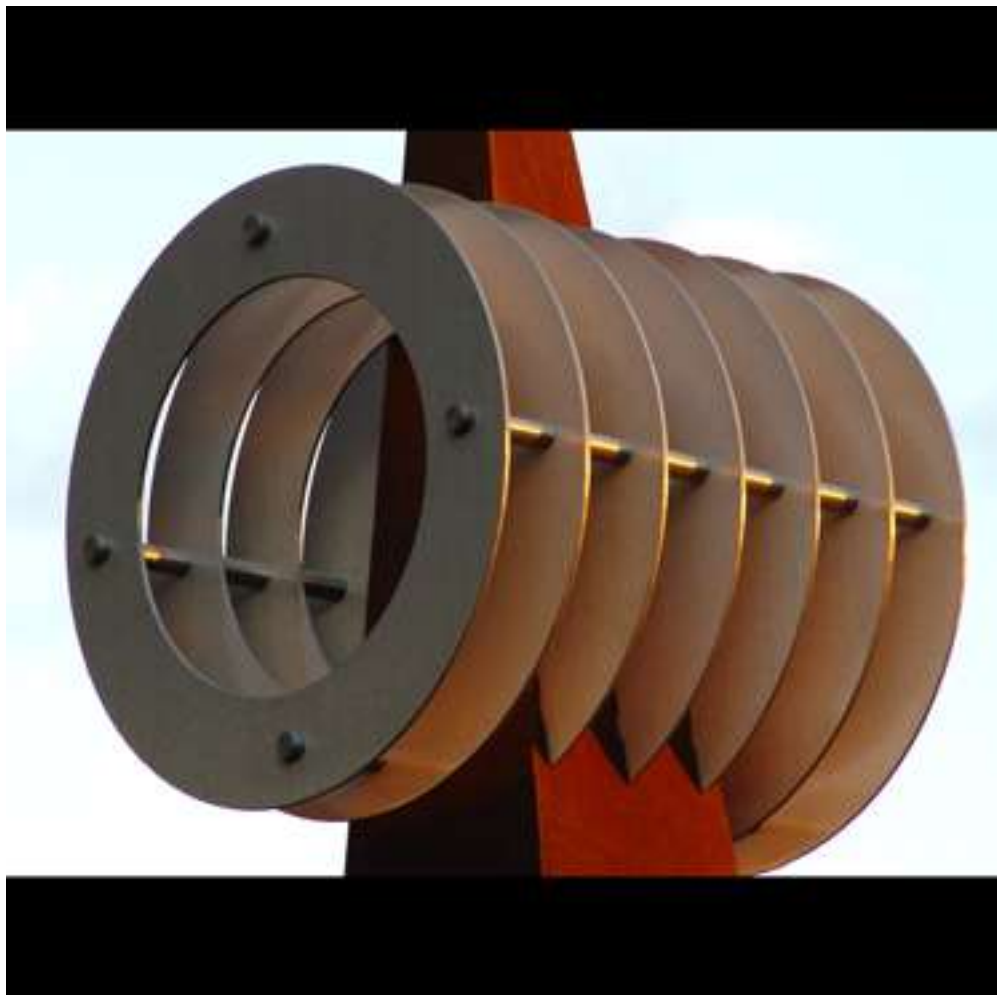

MTFULLER
FUNCTIONAL ARTS

⚡ mtfuller.id8@gmail.com

Art In Public Places

Environmental Graphics

3 Dimensional Built Objects

Extraordinary Ideation

5617074688

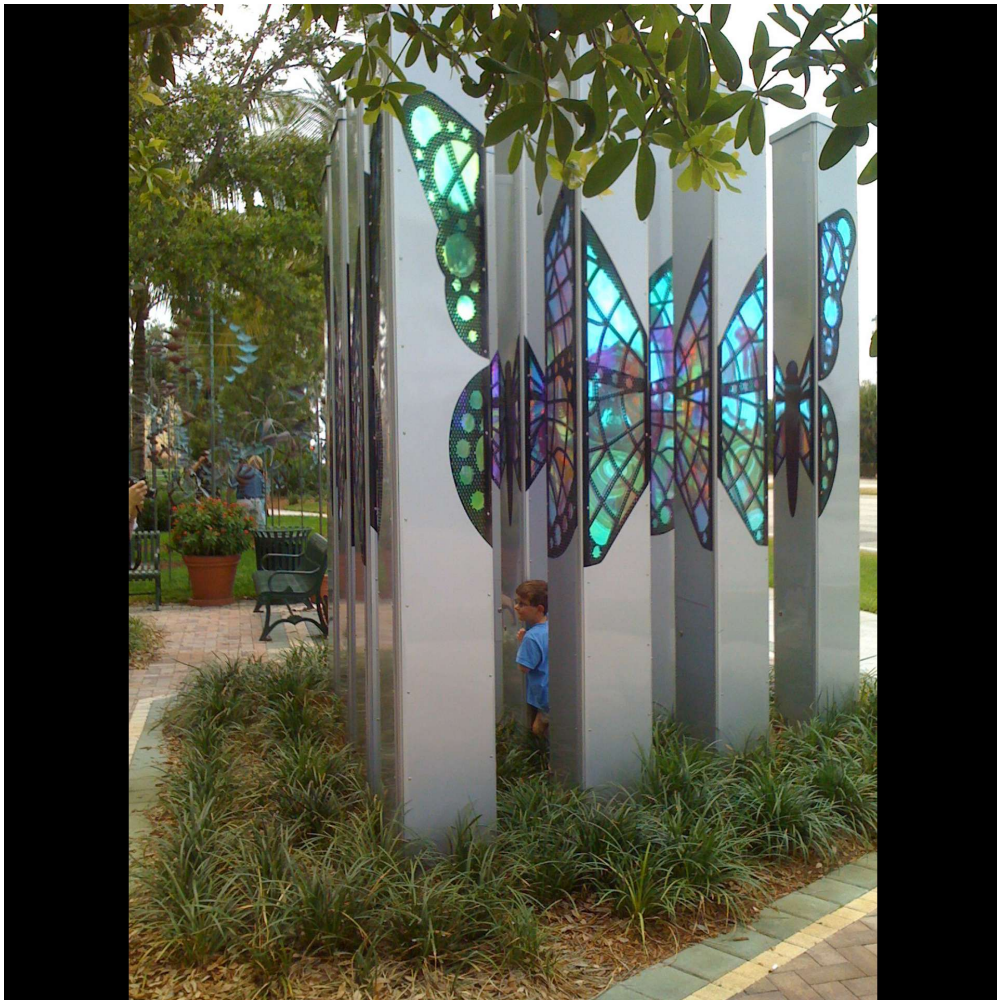

The Butterfly
2004
Palm Beach Gardens, FL

Having already graced the pages of *The New York Times*, *Art & Culture*, and *Privilege Magazine*. this one belongs somewhere in *The Ultimate Book of Cool* when it's finally written!

Morph form. Morph colors. Morph concept into reality. On a drive-by, this baby changes from intact image to fragmented columns of color, and back again. From every viewpoint and angle it presents the observer with a new and different bouquet of color, reflection, and refraction. The rich result of my obsessive tinkering with dichroic coated materials, *The Butterfly* has flown on to become a memorable icon and landmark to all who have fluttered past. Extraordinary. Memorable. Some say beautiful. Better yet, I even like it!

Come visit once the sun is put to bed. When the lights within each of the columns turn on, *The Butterfly* greets you with an entirely different range of fluorescent colored effects. Day or night, it's definitely worth getting out of the car for.

Step into the Cool Age.



MTFULLER
FUNCTIONAL ARTS

⚡ mtfuller.id8@gmail.com

Art In Public Places

Environmental Graphics

3 Dimensional Built Objects

Extraordinary Ideation

5617074688



Track 2; # 1-9
2006
Pinellas County, FL

When 46 miles of railroad gets transformed into a recreation trail, opportunities and challenges arrive. The Pinellas Trail slices through nine communities along Florida's west coast. With design objectives to: uniquely identify each community but clearly link them together as a part of the larger trail family; pay tribute to the history of the trail; be no closer than five feet from the path; and be tough enough to withstand a hurricane, the design challenge for me was on. And soon after, so was my thinking cap.

It wasn't long before the solution arrived in the form of super high-gloss coated colored tubes arcing fifteen-feet above the path. The round tubes glisten in the sun and are self-cleaning in the rain. Banded to mimic the stripes on crossing barriers, the arcs support stylized design interpretations of old railway signals as well as a community identification panel.

Five hurricanes down the line, each marker of *Track 2; 1-9* continues to chug along singing its happy song - unscathed by man, beast, or nature. Woo-hoo!

Step into the Cool Age.



MTFULLER
FUNCTIONAL ARTS

⚡ mtfuller.id8@gmail.com

Art In Public Places

Environmental Graphics

3 Dimensional Built Objects

Extraordinary Ideation

5617074688

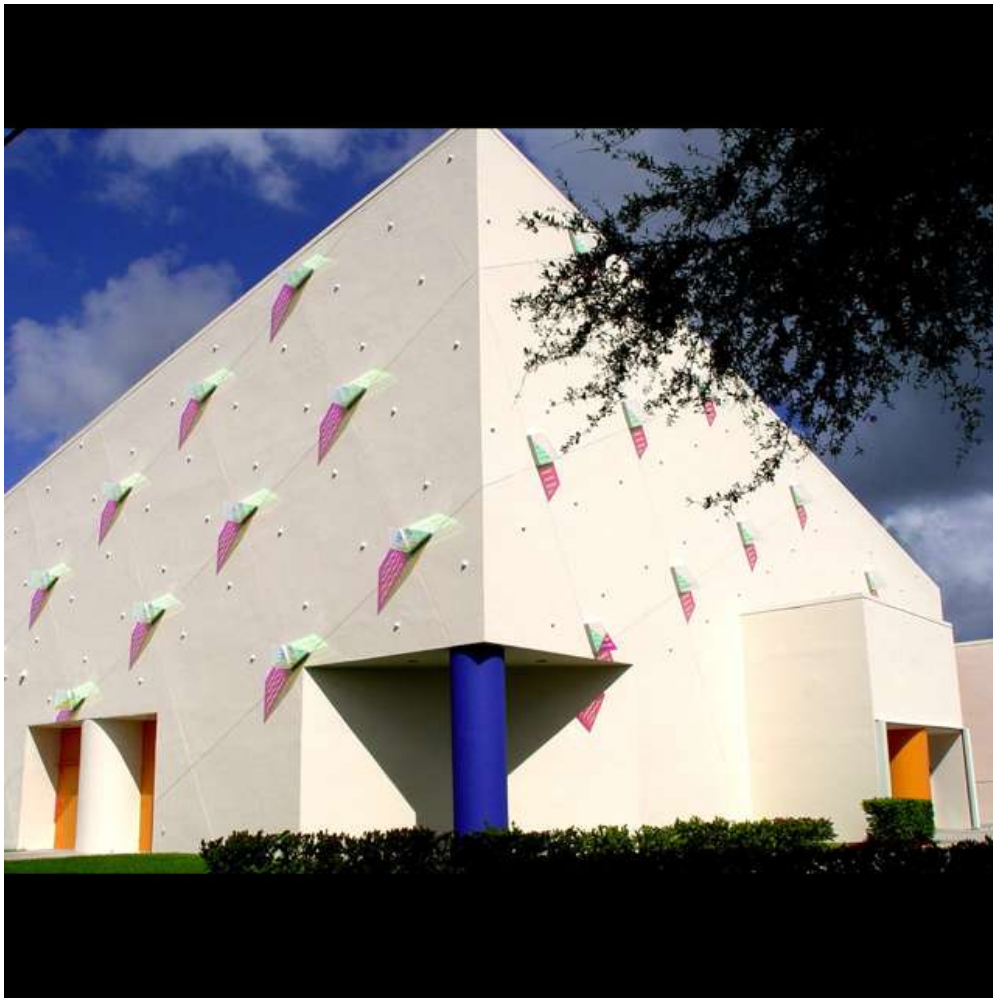

Light Swimming
2007
Delray Beach, FL

Had you asked me for a solution to bring vitality to a civic center that has two large blank, boring walls, *Light Swimming* might have been my answer.

Selected for this commission from a national pool of accomplished artists, Palm Beach County's Art In Public Places chose this design for its ability to cast colored shadows during the day, and pin-points of solar-powered light at night.

Each dichroic coated 'sconce' houses a self-contained solar panel to deliver enough energy to drive the energy for a single super bright LED well into the night. Additional surface texture of shadow and highlight is provided by over 100 four-inch aluminum hemispheres dimpling the walls.

Welcome to the Cool Age.

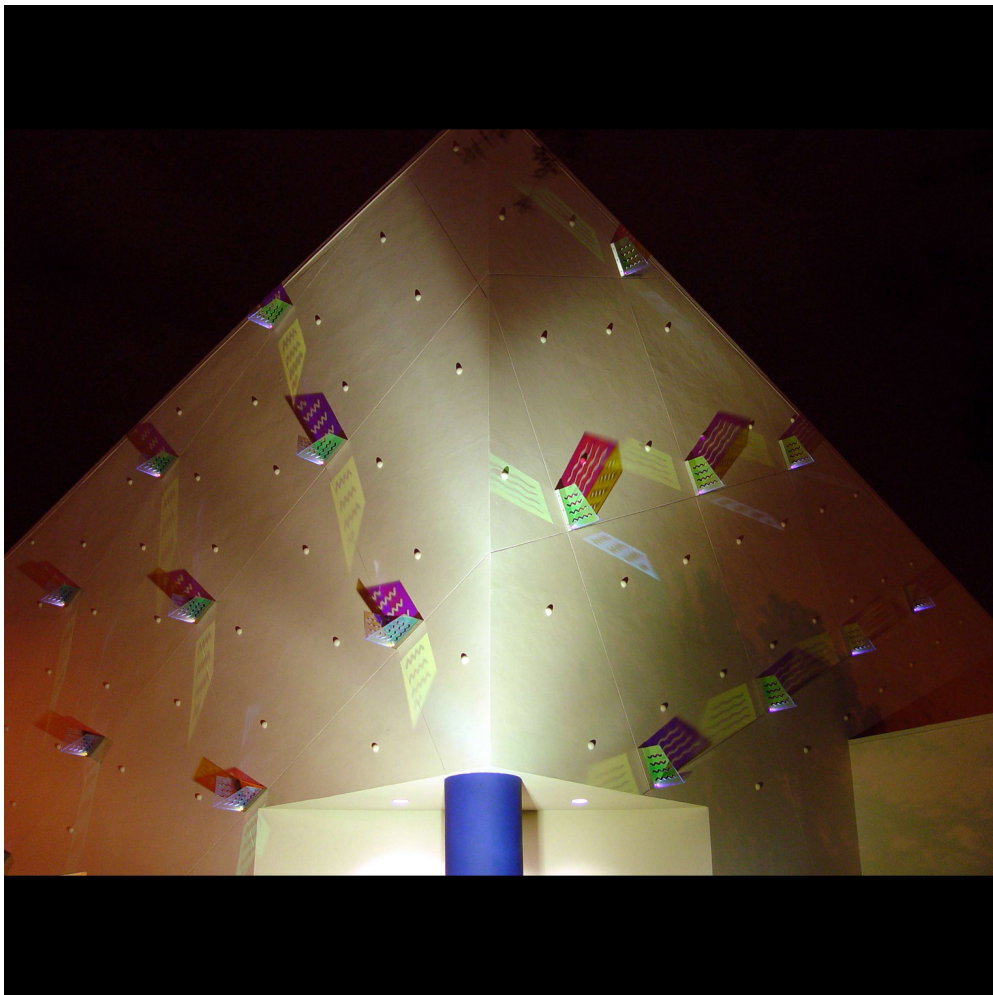

MTFULLER
FUNCTIONAL ARTS

⚡ mtfuller.id8@gmail.com

Art In Public Places

Environmental Graphics

3 Dimensional Built Objects

Extraordinary Ideation

5617074688



Gimme Shelter
2008
Pinellas County, FL

Big shade and four fat seats.
Four doors of breeze.
A garden gazebo with palm fronds and a rainrow.
And a corner from the wind and rain.
Say 'good-bye' to the institutional-grade transit shelter and
'hello' to "I don't mind waiting for the bus."
The only thing missing here is a hammock, a good book,
and an alarm clock.

Gimme Shelter is our latest ADA compliant addition to the west coast street scene, and comes equipped with 86 watts of solar power to launch 18 nine-light arrays of superbright LED lamps. Initially created as a public art installation for Pinellas Suncoast Transit Authority (PSTA), instant fanfare has made it a winner. Plans are already underway for more, so watch for this garden variety in the near future.

Step into the Cool Age.



MTFULLER
FUNCTIONAL ARTS

⚡ mtfuller.id8@gmail.com

Art In Public Places

Environmental Graphics

3 Dimensional Built Objects

Extraordinary Ideation

5617074688



Stack/45
2006
Palm Beach Gardens, FL

Centered in a traffic circle at an upscale retail center, the design of this installation needed to be somewhat transparent so as not to obscure vistas. It was also required that it pay tribute to Hank Skokowski, the project's urban planner who tragically passed away during this, his final planning project. Hank began a love affair with rock music in the early '60's, and amassed a large record collection. I reasoned: record turntables go 'round and 'round and traffic circles go 'round and 'round. Concept: Make the traffic circle a record player with a stack of '60's era 45 RPM vinyl disks on it. Spindle inserts, which came in a wide variety of designs and colors, were required to center 45's on the turntable. On *Stack/45* the five black vinyl records are represented by the black outer arcs. Five record labels are outlined by the smaller colored arcs that match the five spindle insert colors. This abstract arrangement of five stacked records is symbolically arced towards the heavens in a reverent nod. Here, whimsical imagery with it's secret meaning expresses the very personal relationship of a man and his life's work in a subtle but very public way.

Site Specific Art. Defined.



MTFULLER
FUNCTIONAL ARTS

⚡ mtfuller.id8@gmail.com

Art In Public Places

Environmental Graphics

3 Dimensional Built Objects

Extraordinary Ideation

5617074688



Triads
2008
Palm Beach Gardens, FL

Sparkle me, sparkle you.

One minute Triads will fool your eye into believing they are clear glass pyramids and the next you will think they are orange... no, yellow... no, blue... oh whatever, some colored pane of glass; or are they golden mirrors?

In a way, all of these illusions are correct. Made of dichroic coated polycarbonate, Triads reflect the sun throughout the day, while strategically placed individual spotlights beneath each column of the Triads make this building sing in a blaze of theatrical glory throughout the night.

Scaled to suit the optical illusion of the architecture (this building is actually 7 stories tall) the individual Triad units are more than 3ft x 3ft x 3ft each in size.

This dynamic illumination of the building exterior is achieved with only thirteen spotlights.

And, oh yeah... twenty-six Triads.

Welcome to the Cool Age.



MTFULLER
FUNCTIONAL ARTS

⚡ mtfuller.id8@gmail.com

Art In Public Places

Environmental Graphics

3 Dimensional Built Objects

Extraordinary Ideation

5617074688



StentTower
2009
Palm Beach Gardens, FL

As part of my research into this project for this Tenet Healthcare hospital, I took a behind the scenes tour of the cardiology, Radiology, and Cardiology departments. Fascinated with the shapes of red and white blood cells and awed with the technical sophistication of a heart operation I reviewed, it was clear to me that this sculpture should pay tribute to the high-technology of today's medical facilities.

This installation is an abstract representation of red and white blood cells flowing through a heart stent that emerges from an artery.

Welcome to the Cool Age.



MTFULLER
FUNCTIONAL ARTS

⚡ mtfuller.id8@gmail.com

Art In Public Places

Environmental Graphics

3 Dimensional Built Objects

Extraordinary Ideation

5617074688

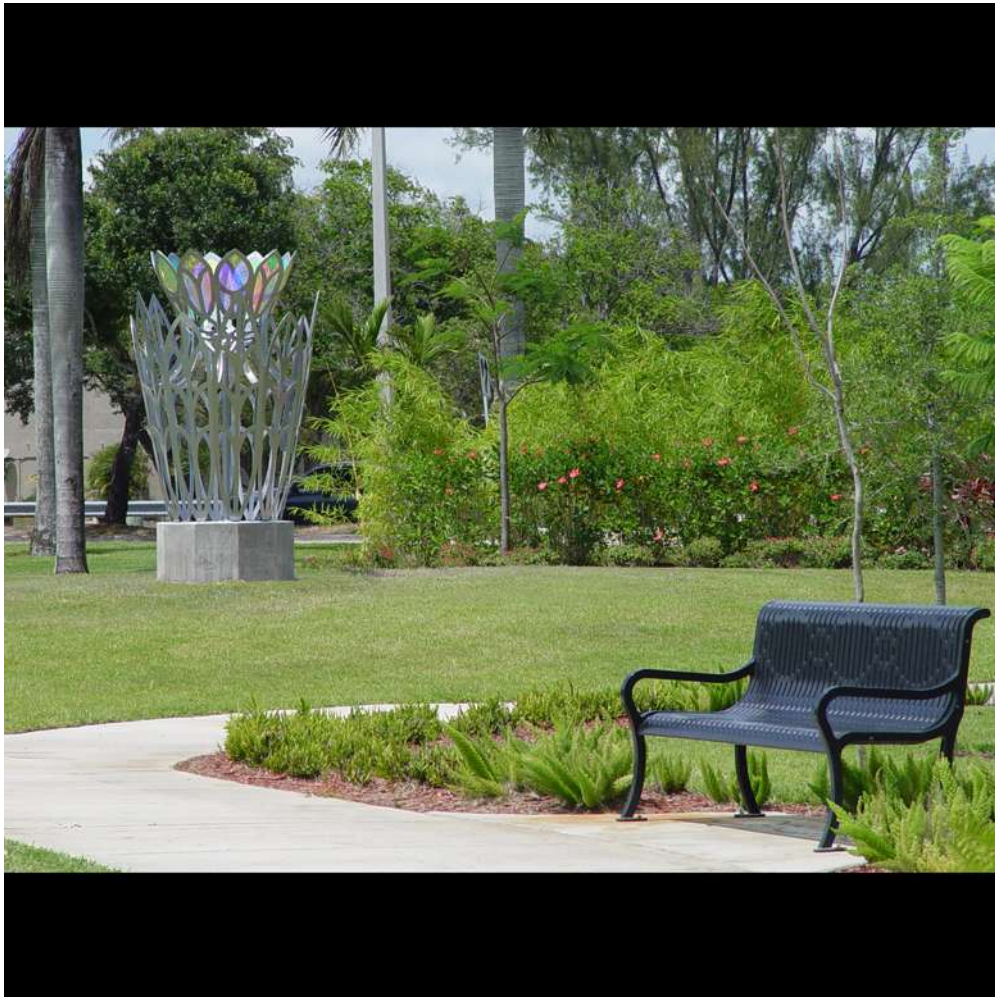

Lotus Agikam
2009
Lauderhill, FL

Selected for the City of Lauderhill's first acquisition to their public art collection, *Lotus Agikam* symbolizes the nature of the Eileen Lieberman Botanical Garden where it is located.

Created as a landmark to visually draw the eye of passers-by into the gardens from the adjacent throughfare, the transparent nature of this installation does not obscure the beauty of the flora and fauna of the gardens.

Welcome to the Cool Age.



MTFULLER
FUNCTIONAL ARTS

⚡ mtfuller.id8@gmail.com

Art In Public Places

Environmental Graphics

3 Dimensional Built Objects

Extraordinary Ideation

5617074688



Cambier's Quilt
2009
Naples, FL

When I was commissioned by the City of Naples to provide their first public art installation in the heart of downtown, it was elementary for me to incorporate the dominant grid geometry found on the building adjacent to the site.

Selected for this project from a national pool of 158 accomplished artists, the city chose my design for its ability to present a constantly changing kalidescope of color from every viewpoint.

Heroically-scaled for the pedestrian experience, these two installations contain a total of 216 dichroic coated polycarbonate panels arranged in three staggered vertical planes. It's best I not try to explain! You'll have to take my word on it when I say the kalidescope effect was pulled off successfully!

Welcome to the Cool Age.

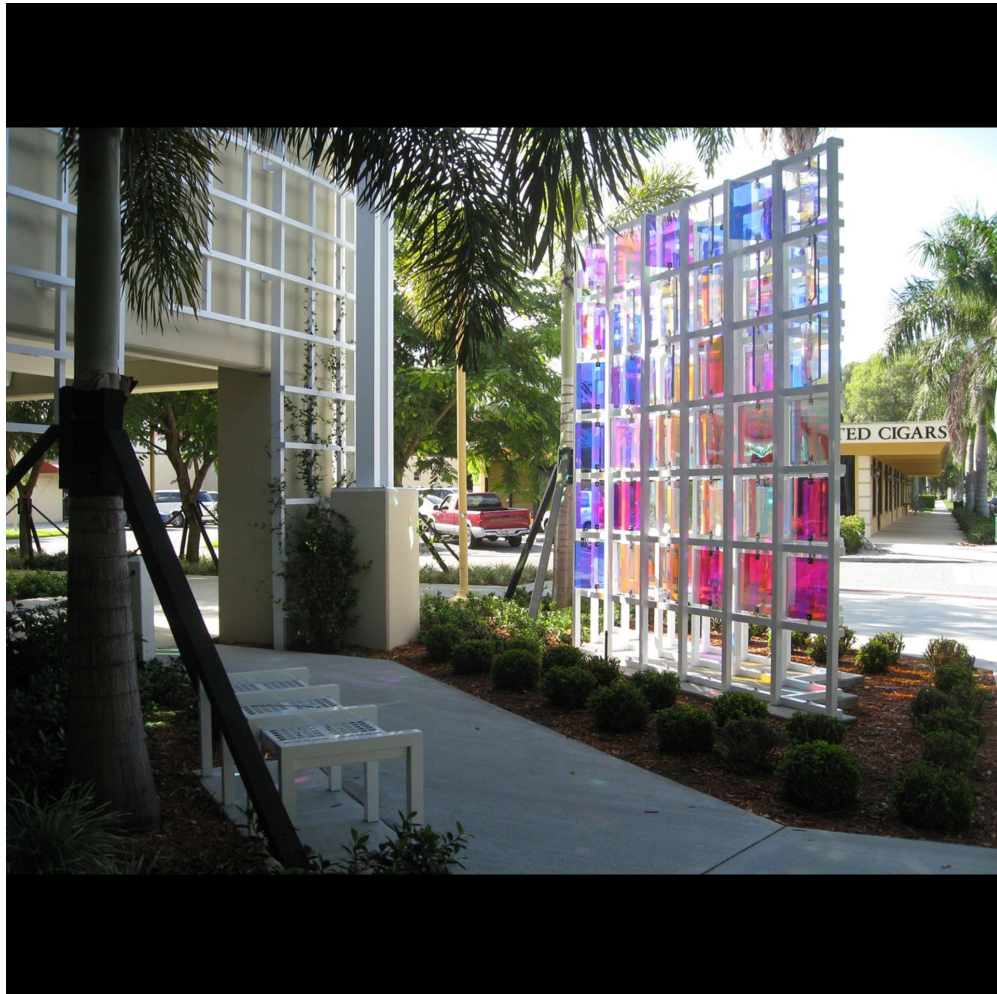

MTFULLER
FUNCTIONAL ARTS

⚡ mtfuller.id8@gmail.com

Art In Public Places

Environmental Graphics

3 Dimensional Built Objects

Extraordinary Ideation

5617074688



The Tipping Point
2009
Royal Palm Beach, FL

When the Village of Royal Palm Beach approached their 50th Anniversary, they felt it fitting to celebrate the occasion by purchasing their first public art sculpture.

To illustrate the village's population growth from 11 residents to 38,000 over the fifty years, I chose a frond image. With a mirrored geometry visually familiar of various tropical plants and palms, these five 'leaves' represent the five decades of Royal Palm Beach's fertile growth. Ranging in size from eight to twelve feet, the mirror-polished stainless steel and dichroic coated leaves are the pristine centerpiece at this primary intersection in the community.

This installation is named after *The Tipping Point*; a book by Malcolm Gladwell. Tipping points are the levels at which the momentum for change becomes unstoppable; the moment of critical mass.

This occasion; this moment of finding the civic acquisition of art to be socially important marks a major tipping point in the growth of this community.

Welcome to the Cool Age.



MTFULLER
FUNCTIONAL ARTS

⚡ mtfuller.id8@gmail.com

Art In Public Places

Environmental Graphics

3 Dimensional Built Objects

Extraordinary Ideation

5617074688



Key / Location:

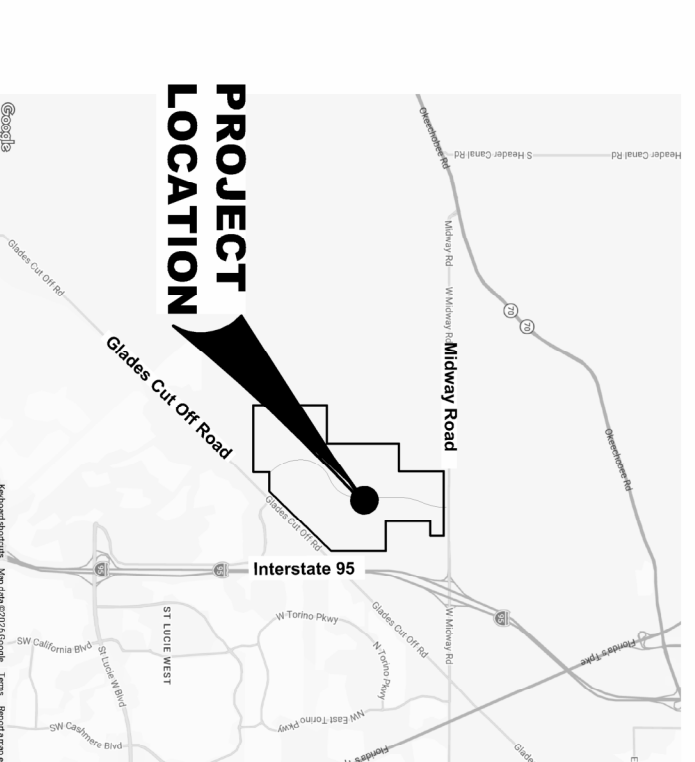

Project Team:

Client & Property Owner: Midway Gates Developer
 7601 Baymeadows Road, Suite 205
 Jacksonville, Florida 32256

Land Planner / Landscape Architect: Lucido & Associates
 701 East Ocean Boulevard
 Stuart, Florida 34994

Engineer: Kimley-Horn And Associates
 445 24th Street, Suite 200
 Vero Beach, Florida 32960

Surveyor: Geopoint
 4450 West Eau Gallie Blvd.
 Suite 130 Melbourne, Florida 32934

Wylder Art In Public Places Hardscape Plan

Port St Lucie, Florida
 P23-132
 PSLUSD# xx-xxx-xxx

Date	By	Description
04.01.26	EMA	Submittal

SCALE: 1" = 20'

REG. #6667114
 Steven D. Garrett

HS1

Designer / Manager	EMA	Sheet
SG		
Project Number	26-060	
Municipal Number	P23-132	
Computer File	26-060 - Wylder A1P1e At Commercial - Submittal Site P	

© Lucido & Associates, Inc. Associates and their clients own the property of Lucido & Associates. All reproductions, resales, modifications or use of these documents without the express written consent of Lucido & Associates is prohibited by law.

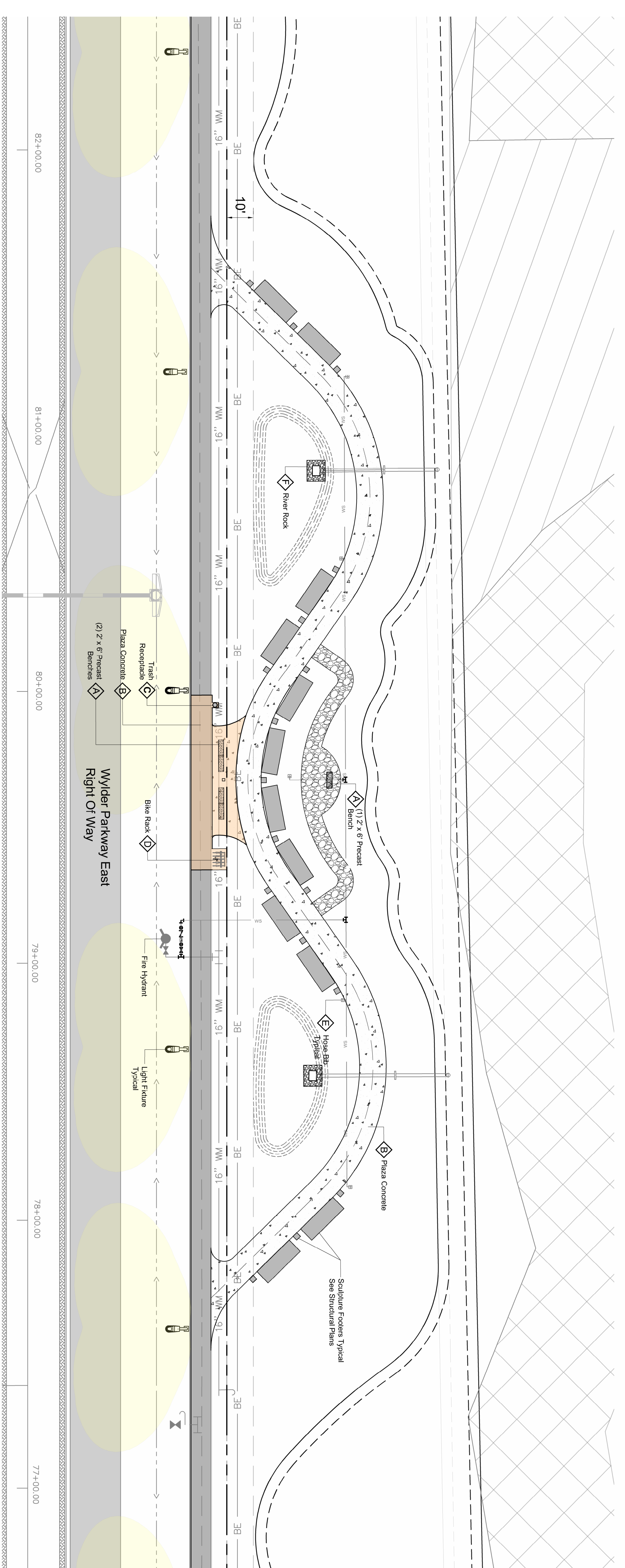

West Plaza Art In Public Places Hardscape Plan - Phase 1
 Residential Public Art Requirement
 Scale: 1" = 20'

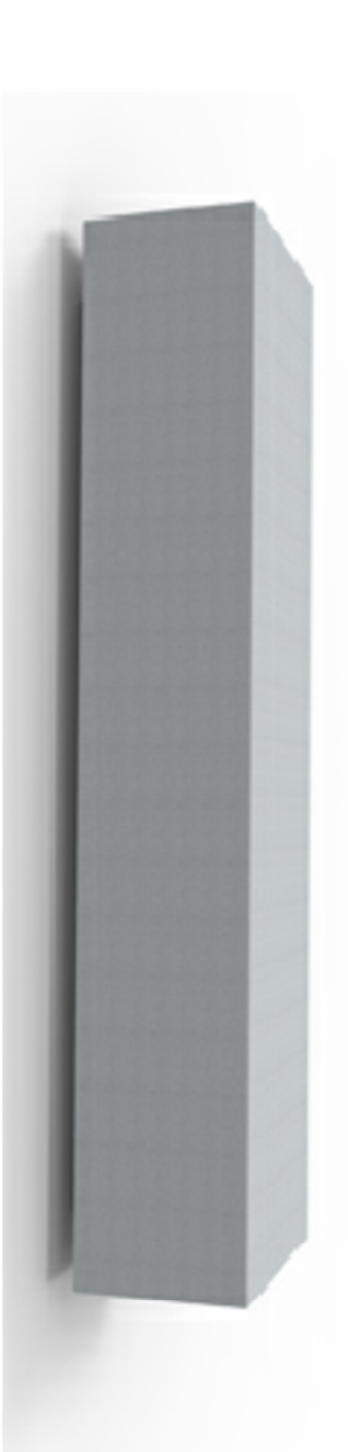

A Bench
 Florida Architectural Precast
 2' x 6' Precast Bench



B Plaza Concrete
 Scofield Polishing Systems
 Color - TBD

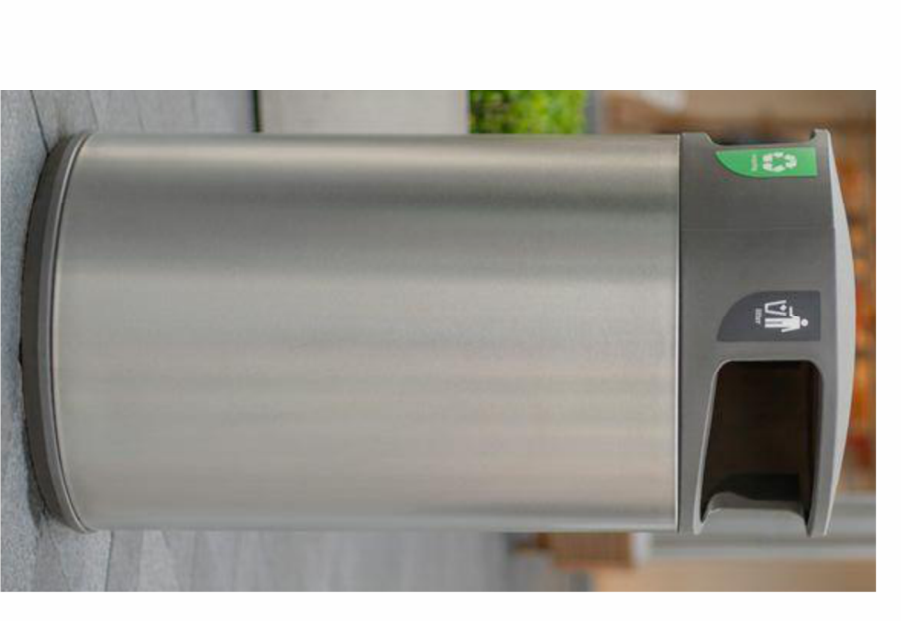

C Trash Receptacle
 Forms + Surfaces (Configuration)
 Universal Receptacle
 SLUNN-30SSS

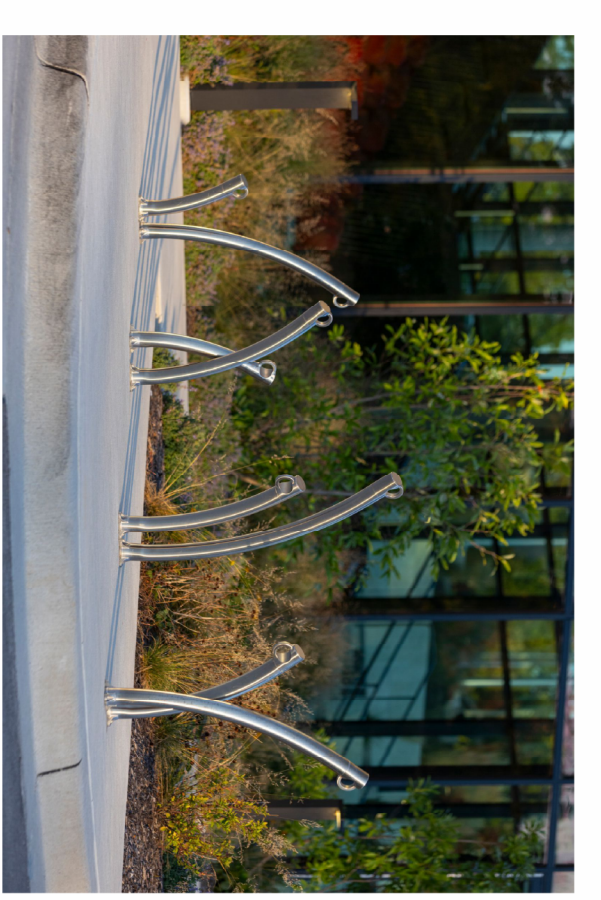

D Bike Rack
 Forms + Surfaces
 Bike Garden Bike Rack
 Configuration A-SM



E Hose Bib
 Murdock
 M-V477 Cast Bronze Box
 Ground Hydrant w Vacuum Breaker
 Stainless Steel - Surface Mounted



F River Rock
 Neptune Nursery
 White Marble River Rock
 57 Rock or Marble Rock 3/4"

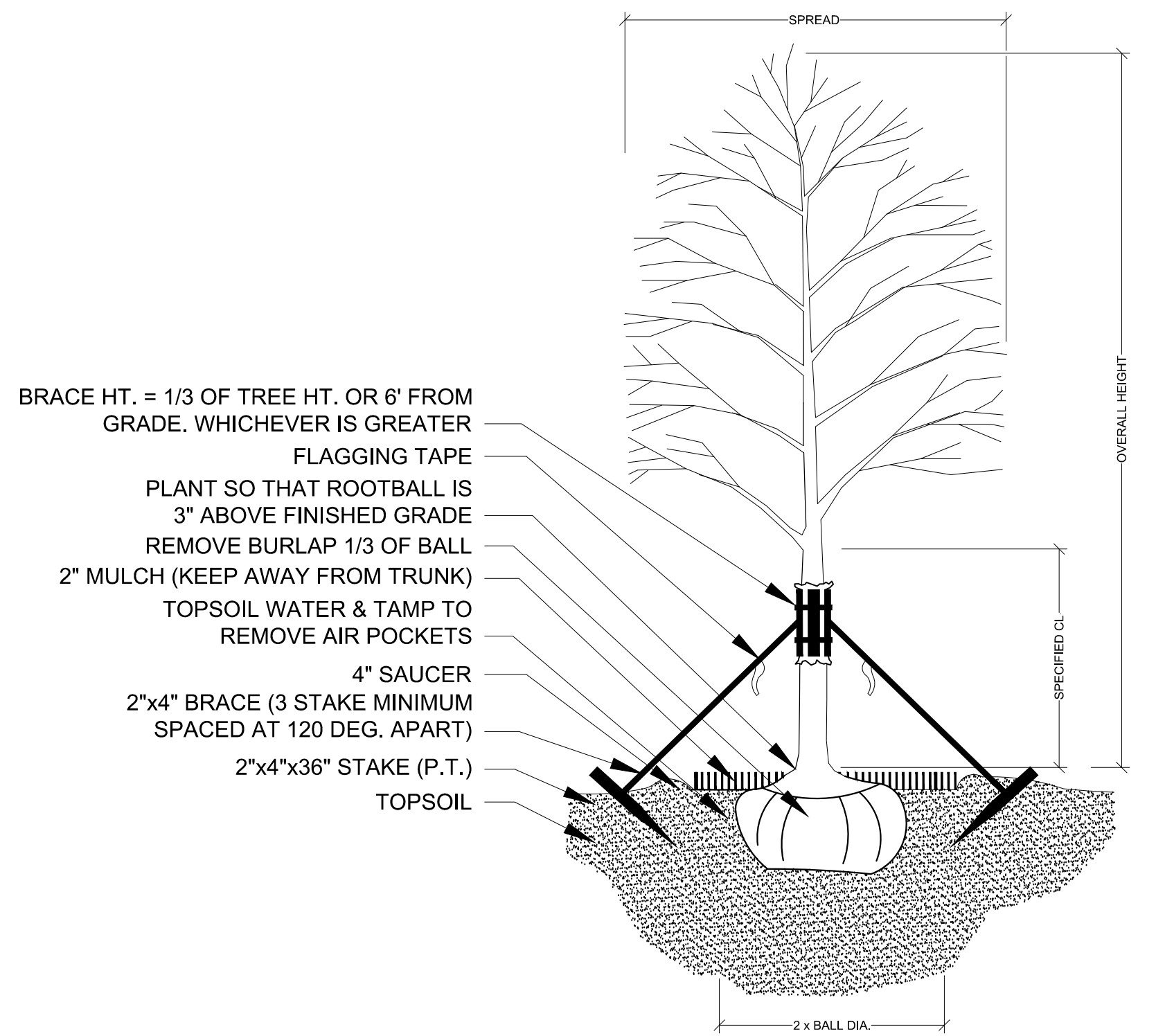

TREE PLANTING & STAKING
 NOT TO SCALE

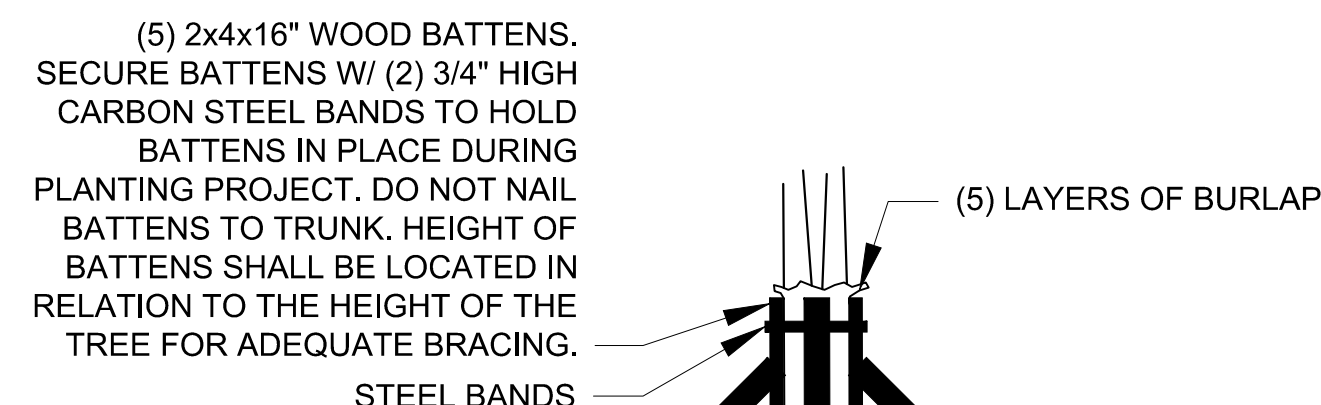

BRACING DETAIL
 NOT TO SCALE

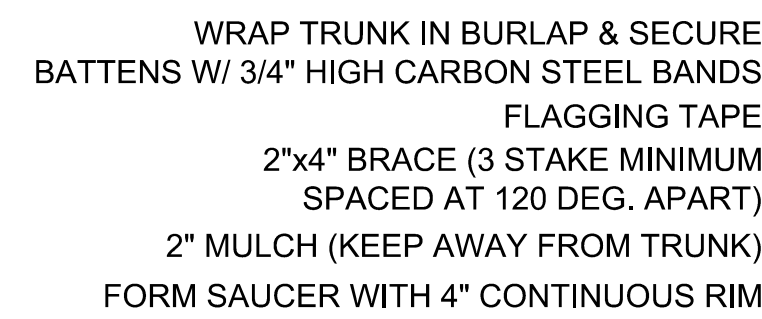

PALM PLANTING - ANGLE STAKE
 NOT TO SCALE

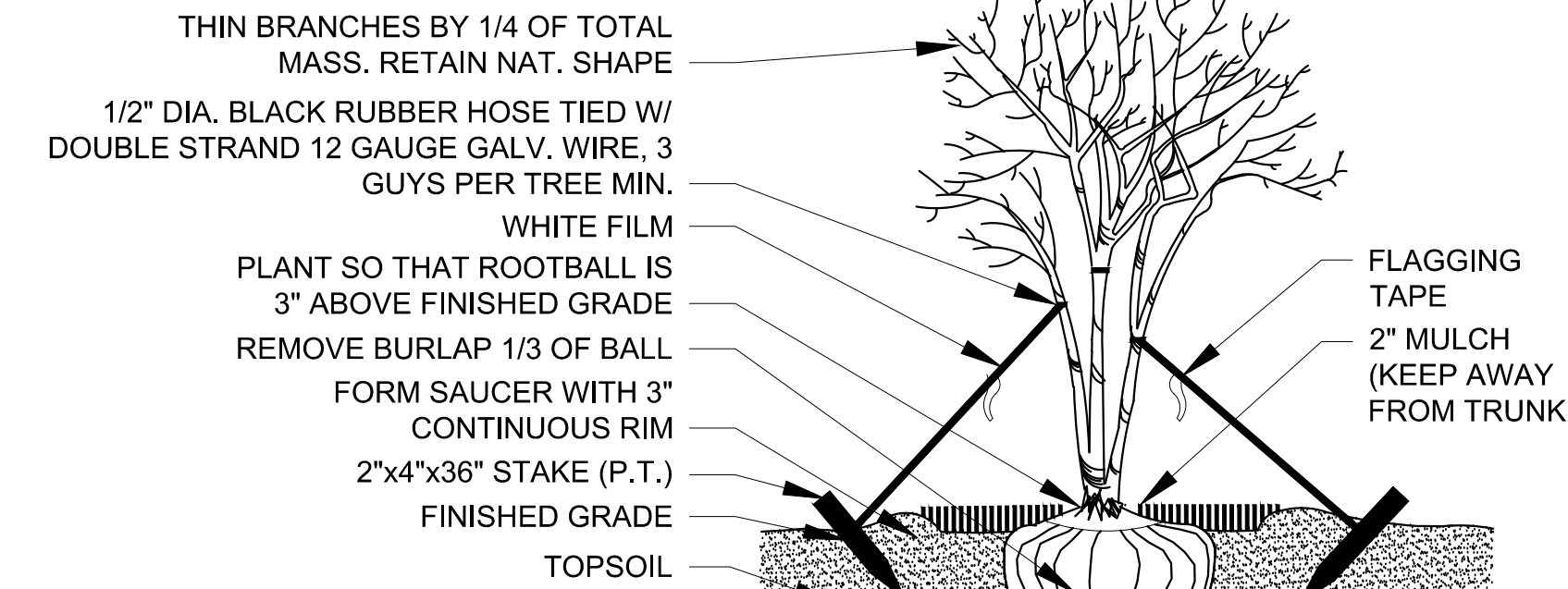

MULTI-TRUNK PLANTING & GUYING
 NOT TO SCALE

Key / Location:

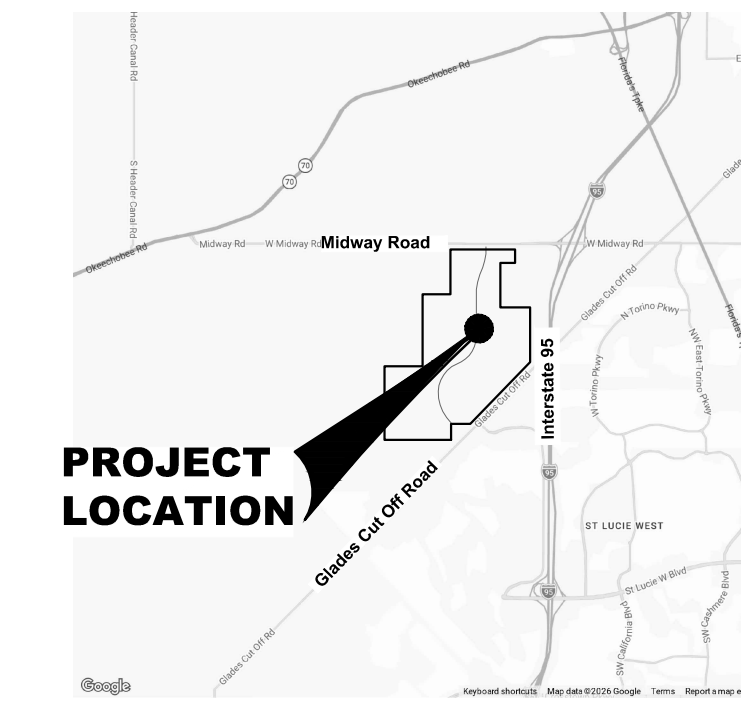

Project Team:

Client & Property Owner: Midway Glades Developer
 7807 Baymeadows Road, Suite 205
 Jacksonville, Florida 32256

Land Planner / Landscape Architect: Lucido & Associates
 701 East Ocean Boulevard
 Stuart, Florida 34994

Engineer: Kimley Horn And Associates
 445 24th Street, Suite 200
 Vero Beach, Florida 32960

Surveyor: Geopoint
 4450 West Eaugallie Blvd.
 Suit 130 Melbourne, Florida 32934

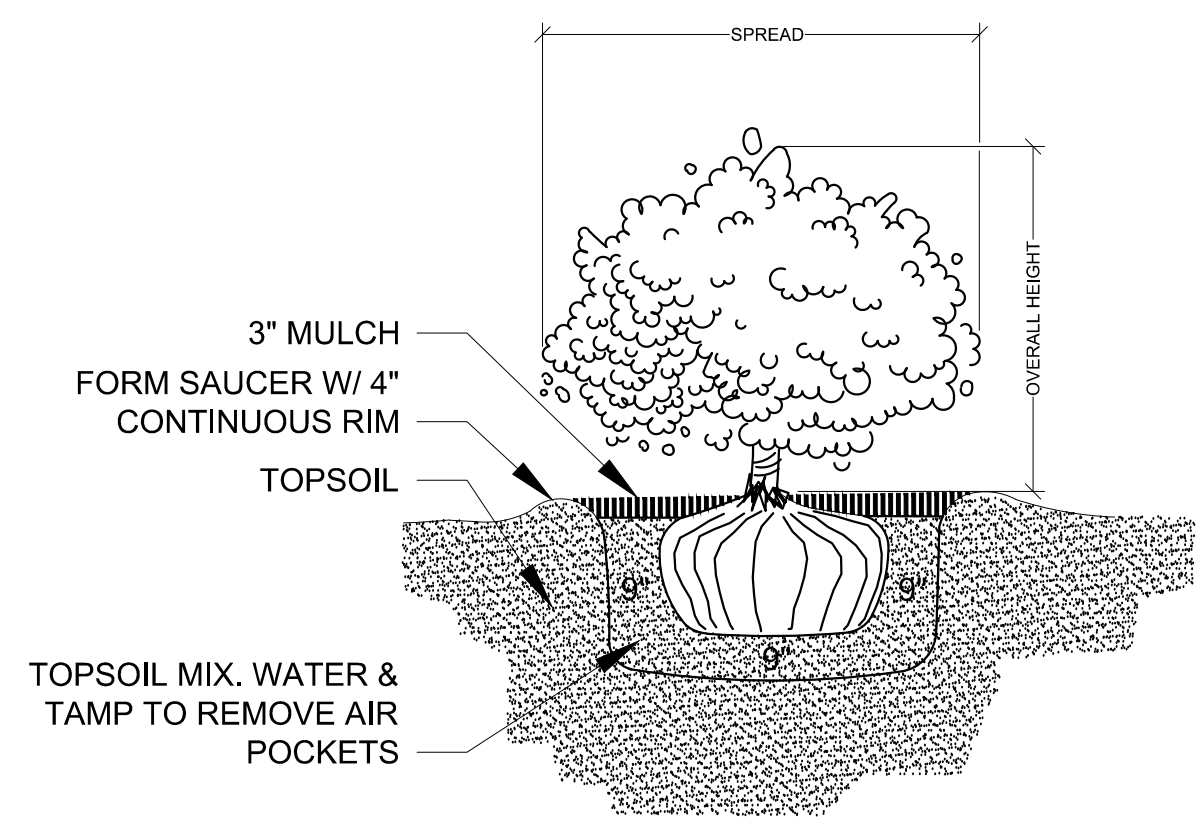

SHRUB PLANTING
 NOT TO SCALE

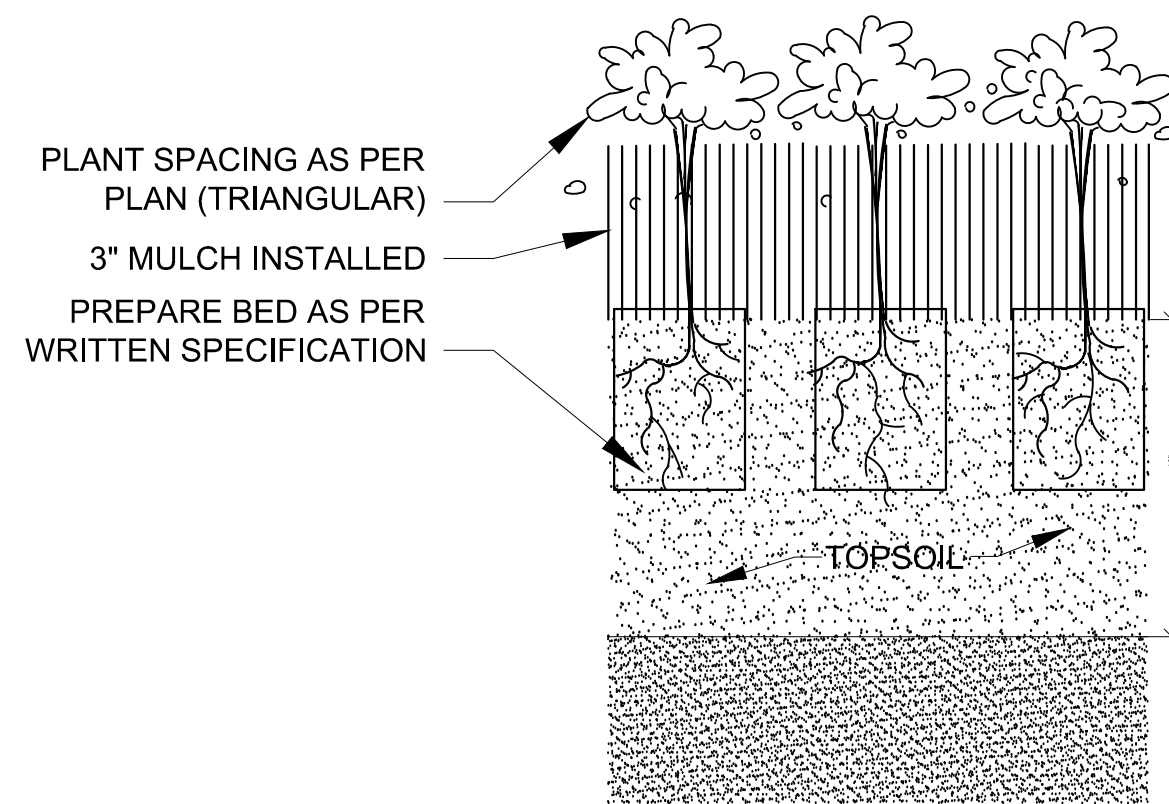

GROUNDCOVER PLANTING DETAIL
 NOT TO SCALE

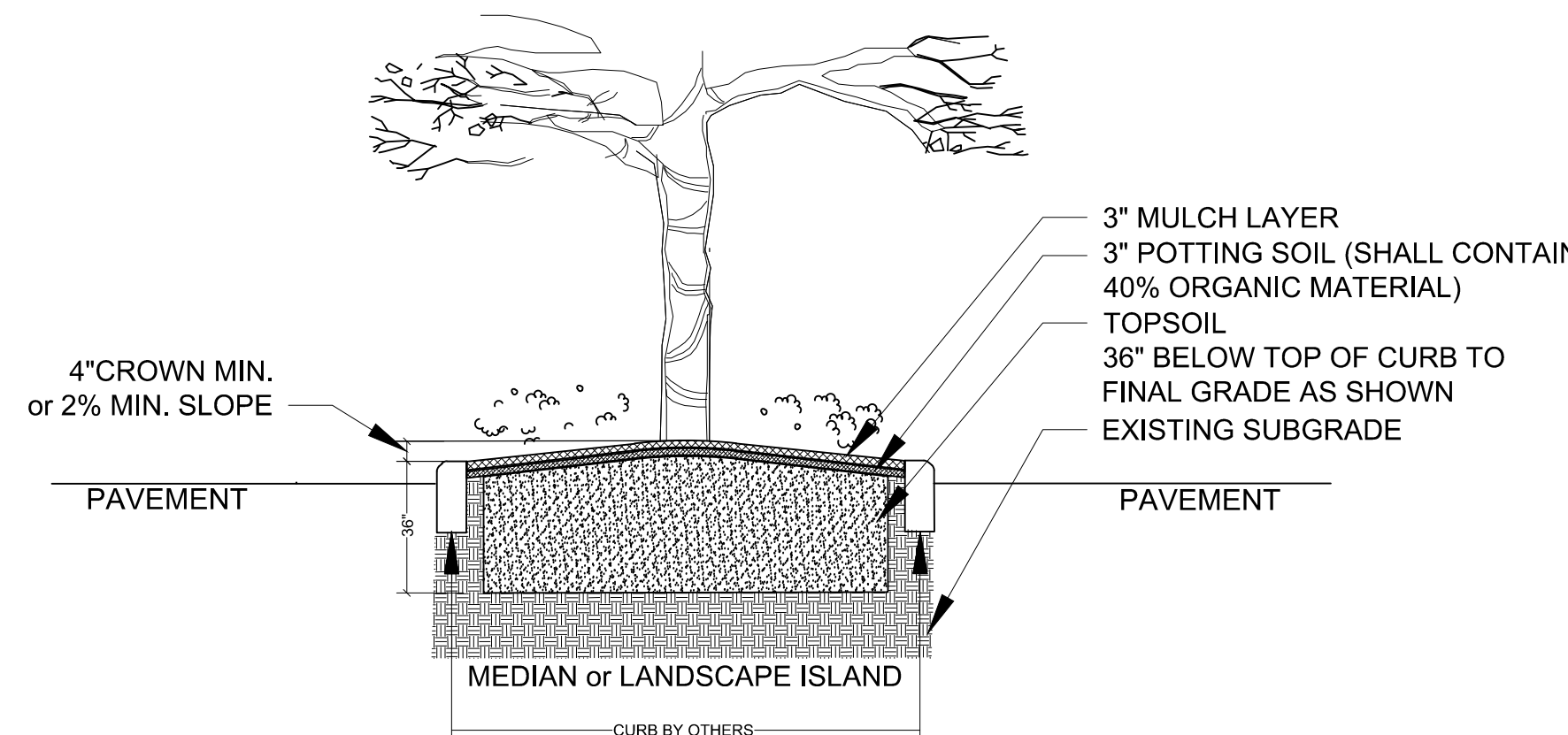

LANDSCAPE AREA PREPARATION DETAIL
 NOT TO SCALE

- THIS DETAIL SHOWN DEPICTS A MEDIAN AND/OR LANDSCAPE ISLAND AND IS FOR GRAPHIC PURPOSES ONLY; SOIL PREPARATION SHALL APPLY TO ALL TREE, SHRUB, & GROUND COVER AREAS. THIS DOES NOT INCLUDE SOD AREAS
- * TOPSOIL SHALL BE NATURAL, FRIABLE, FINE LOAMY SOIL POSSESSING CHARACTERISTICS OF REPRESENTATIVE TOPSOIL IN THE VICINITY OF THE PROJECT SITE THAT PRODUCES HEAVY GROWTH.
 - TOPSOIL SHALL HAVE A PH RANGE OF 5.5-7.4, FREE FROM SUBSOIL, WEEDS, LITTER, SODS, CLAY, STONES, STUMPS, ROOTS, TRASH, HERBICIDES, TOXIC SUBSTANCES, OR ANY OTHER MATERIAL WHICH MAY BE HARMFUL TO PLANT GROWTH, OR HINDER PLANTING OPERATIONS.
 - TOPSOIL SHALL CONTAIN A MINIMUM OF 3% ORGANIC MATERIAL.
 - TOPSOIL MUST PERCOLATE WATER AT A RATE OF 1" PER HOUR (SEE ALSO DRAINAGE TESTING DETAIL FOR TREES)
 - LANDSCAPE AREA SOILS SHALL BE APPROVED BY LANDSCAPE ARCHITECT/OWNER PRIOR TO PLANTING

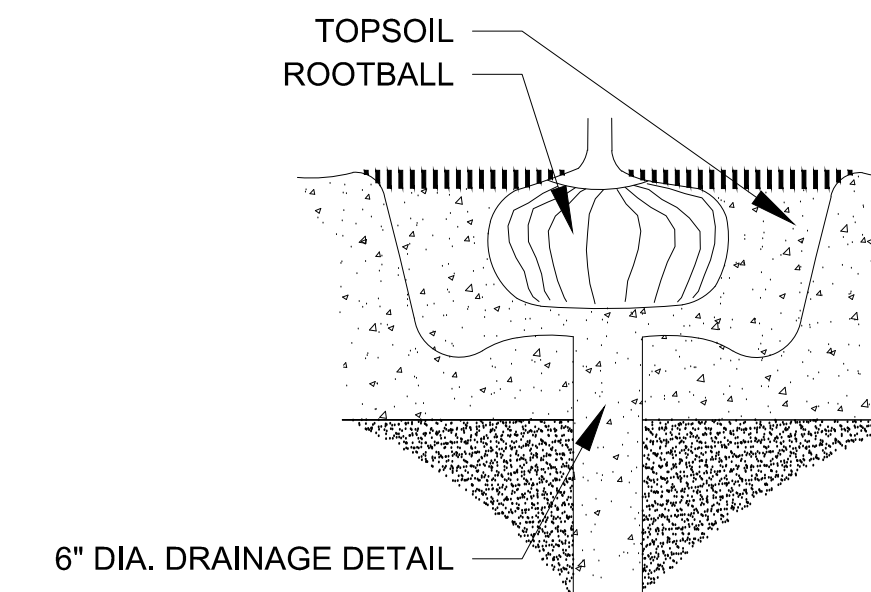

DRAINAGE TESTING DETAIL
 NOT TO SCALE

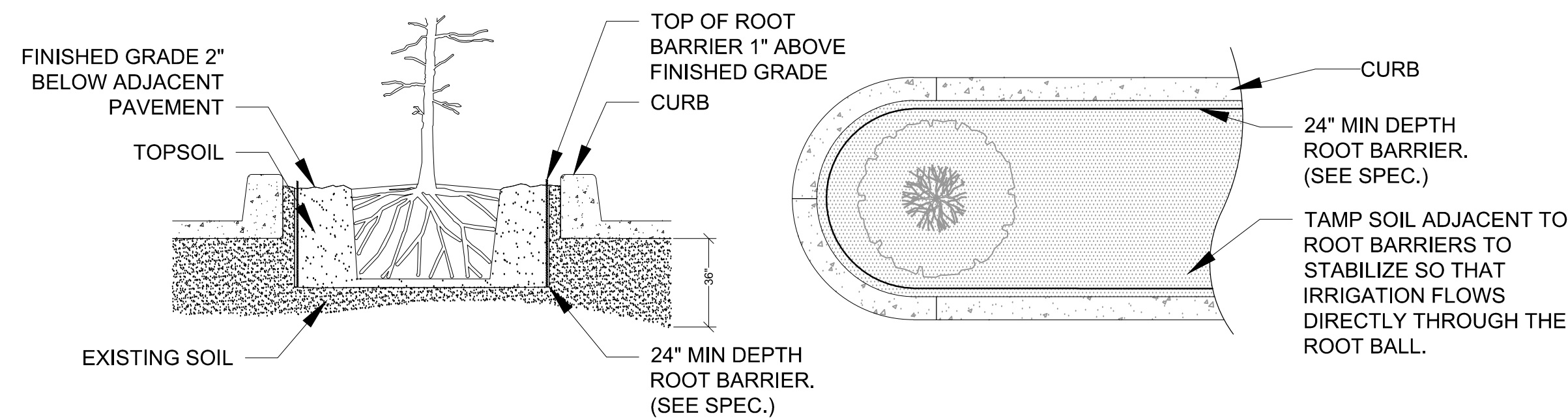

SPECIAL APPLICATIONS ROOT BARRIER DETAIL
 NOT TO SCALE

- NOTES:
 1- ROOT BARRIER SHALL BE "DEEPROOT ROOT BARRIER 24" DEPTH OR APPROVED EQUAL.
 2- ROOT BARRIER SHALL BE INSTALLED PER MANUFACTURER'S SPECIFICATIONS AND RECOMMENDATIONS.
 3- IF REQUIRED BY A MUNICIPALITY AND IN INSTANCES WHERE A TREE(S) IS PLANTED CLOSER THAN 5' FROM A SIDEWALK, OR STRUCTURE, A ROOT BARRIER(S) SHALL BE INSTALLED. ROOT BARRIERS FOR TREES SHALL BE INSTALLED ALONG THE EDGE OF THE STRUCTURE, PAVING OR CURB. THE ROOT BARRIER SHALL BE INSTALLED WITH 20 LF CENTERED FROM THE TRUNK FOR LARGE TREES AND 15 LF FOR SMALL TREES AND PALMS.

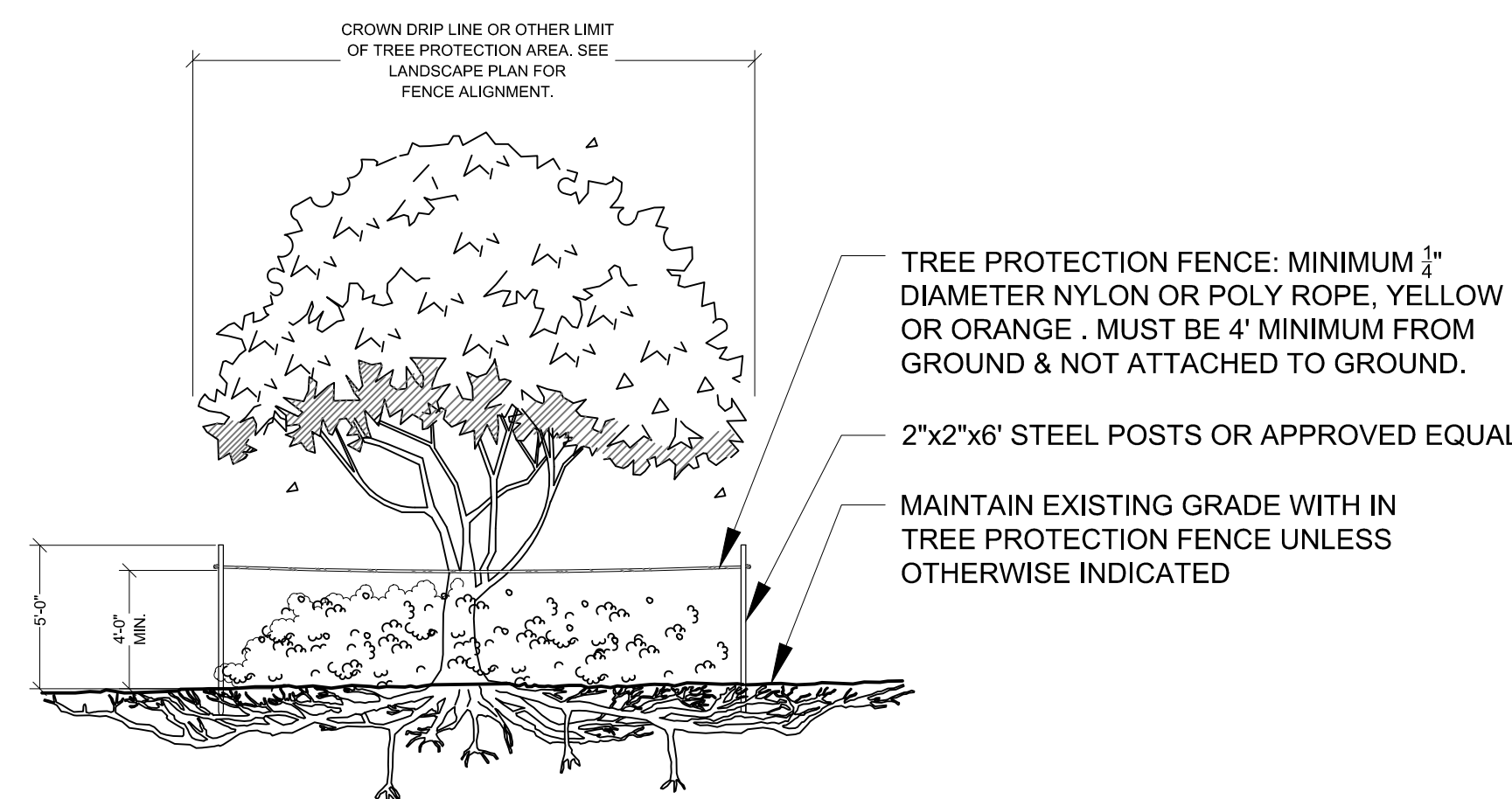

TREE PROTECTION BARRICADE
 NOT TO SCALE

- NOTES:
 1- SEE LANDSCAPE PLAN FOR FENCE ALIGNMENT.
 2- NO PRUNING SHALL BE PERFORMED EXCEPT BY APPROVED ARBORIST.
 3- NO EQUIPMENT SHALL OPERATE INSIDE THE PROTECTIVE FENCING INCLUDING DURING FENCE INSTALLATION AND REMOVAL.

DRAINAGE TESTING/DRAINAGE CHANNEL REQUIREMENTS.

PRIOR TO PLANTING, ALL PLANTING PITS SELECTED FOR TESTING SHALL BE TESTED IN THE FOLLOWING MANNER.

- DIG EACH PLANTING PIT TO THE MINIMUM SPECIFIED SIZE.
- FILL PLANTING PIT WITH TWELVE INCHES (12") OF WATER. IF THE WATER LEVEL DROPS FOUR (4") OR MORE WITHIN FOUR (4) HOURS, THE DRAINAGE IS SUFFICIENT AND A DRAINAGE CHANNEL IS NOT REQUIRED. IF THE WATER LEVEL DROPS LESS THAN FOUR INCHES (4") WITHIN THE FOUR (4) HOUR PERIOD, A DRAINAGE CHANNEL IS REQUIRED.
- WHERE REQUIRED, THE DRAINAGE CHANNEL MUST EXTEND DOWN THROUGH THE NON POROUS SOIL AND INTO POROUS SOIL. (SEE DETAIL)
- ALL MATERIAL REMOVED FROM THE DRAINAGE CHANNEL SHALL BE DISCARDED.
- WHEN BACKFILLING PLANTING PITS WITH NATIVE TOPSOIL, CARE MUST BE TAKEN TO KEEP THE CONSISTENCY OF THE SOIL MIX THE SAME THROUGHOUT THE PLANTING PIT AND DRAINAGE CHANNEL.

Wylder Art In Public Places

Landscape Details

Port St Lucie, Florida
 P23-132
 PSLUSD# xx-xxx-xxx

Date	By	Description
04.01.26	EMA	Submittal

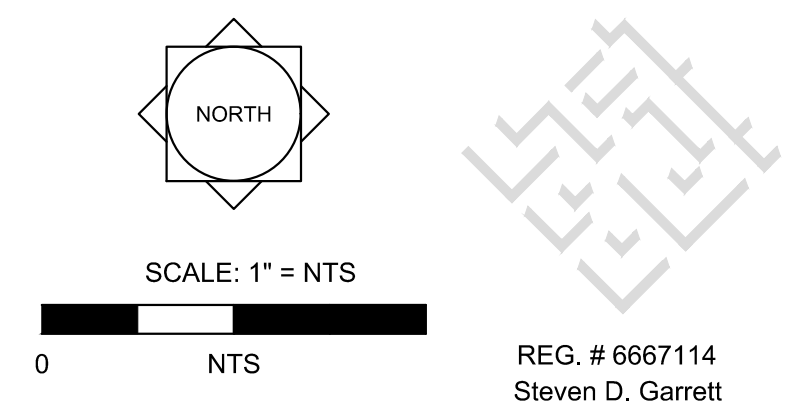

Designer	EMA	Sheet
Manager	SG	
Project Number	26-060	
Municipal Number	P23-132	
Computer File	26-060 - Wylder AIPP At Commercial - Submittal Site P	

LA2

**Wylder Public Art
Art Sculptures and Site Furnishings - Estimate of Probable Cost**

3/24/2026

ITEM NO.	DESCRIPTION	UNIT	QUANTITY	UNIT PRICE	PROJECT COST
01	SCULPTURES (12 PARENT CLUSTER INSTALLATIONS)	LS	12	\$ 86,786.66	\$ 1,041,439.92
02	SCULPTURES (17 SPROUT CLUSTER INSTALLATIONS)	LF	17	\$ 12,898.18	\$ 219,269.06
03	BENCHES - 23 3/4" x 17 3/4" x 6'-0"	EACH	5	\$ 2,250.00	\$ 11,250.00
04	TRASH RECEPTACLE	EACH	1	\$ 1,350.00	\$ 1,350.00
05	BIKE GARDEN BIKE RACK	EACH	1	\$ 2,400.00	\$ 2,400.00
TOTAL					\$ 1,275,708.98
CONTINGENCY				20.0%	\$ 255,141.80
GRAND TOTAL					\$ 1,530,850.78



**City of Port St. Lucie
Public Art Requirements
Information Package, Application, and Checklist**

Applicability

The public art assessment applies to all private non-residential development projects and all residential development projects with more than 10 units, subdivision plats, new construction, or the renovation or improvement of an existing building where 50% or more of a building is being modified, renovated, expanded, rebuilt or improved by construction. The public art assessment for any single project cannot exceed **\$100,000**.

All applicable private development must elect one of the following assessment methods and submit to the Planning and Zoning Department a completed Public Art Assessment Application and provide a copy of the total construction costs as indicated on the construction contract(s) within 90 days of the issuance of the first building permit or site work permit for a subdivision plat for any portion of the project.

Total Construction Costs means the total cost of the improvements, exclusive of land, approved for a development project, as indicated on the construction contract(s) for the subject improvements.

Option 1	<p><u>On-site Artwork</u></p> <p>A. Submit documentation evidencing the escrow of funds for a work of art valued in an amount not less than 1% of the total construction costs. *</p> <p>B. Submit an application for approval of the work of art.</p> <p>C. If a local artist is commissioned, the artwork shall be valued at no less than 90% of 1% of the total construction costs. *</p> <p>D. Local artist means an artist who resides in St. Lucie, Martin, Indian River, or Okeechobee counties.</p>
Option 2	<p><u>Contribute to the Art in Public Places Fund</u></p> <p>A. Contribute an amount equal to 80% of the 1% of the total construction costs for deposit to the Art in Public Places fund. *</p>
Option 3	<p><u>On-Site Artwork and Contribute to Fund</u></p> <p>A. Submit documentation evidencing the escrow of funds for a work of art valued in an amount not less than one percent (1%) of the total construction costs.</p> <p>B. Contribute 80% of the balance of the 1% of the total construction costs for deposit in the art in public places fund. *</p>
Option 4	<p><u>Alternative Equivalent Proposal</u></p> <p>A. Submit an alternative equivalent proposal to the Planning and Zoning Director.</p> <p>B. The proposal may seek a combination of the public art assessment associated with multiple projects into one larger work of art in lieu of several small works of art.</p>

* If 1% of the total construction costs exceeds \$100,000, the public art assessment is capped at \$100,000, with no further reductions. The cap represents a reduction.

Location of Public Art

Artwork must be located in an exterior place defined as any place, public or private, outdoor and exterior to buildings or structures and exposed to public view, including, but not limited to, buildings, parks, right-of-way medians, and open spaces.

Definition of Public Art

Art, artwork, or work of art means an original physical work created or produced by an **Artist** including, but not limited to:

- | | | | |
|-------------|---------------|-------------------------------|------------|
| ◆ paintings | ◆ sculptures | ◆ site specific installations | ◆ carvings |
| ◆ statues | ◆ mosaics | ◆ mobiles | ◆ murals |
| ◆ engraving | ◆ bas reliefs | ◆ frescos | ◆ collages |

Artwork may be free-standing or integrated with the work of other design professionals in a building or site. Artwork may be new or may be an existing work of art.

The following **shall not be** considered public art or public works of art:

- Art objects that are mass-produced or are of standard manufacture such as playground equipment, fountains, statuary elements, signage, maps, corporate logos, or other functional elements, unless incorporated into an artwork by an artist commissioned for that purpose.
- Reproductions, by mechanical or other means, of original artwork, except in the case of limited editions controlled by the artist, cast sculpture, film, video, photography, printmaking, or other media arts.
- Works that are decorative, ornamental, or functional elements of the architecture or landscape design; except where designed by a visual artist and/or are an integral part of the artwork by the artist.
- Services or utilities necessary to operate and maintain an artwork over time.

Application and Approval Process

Option 1. *On-site Artwork*

The developer must submit an electronic copy of the application, via Fusion under the associated project number, for onsite artwork and required attachments to the Planning and Zoning Department for distribution to the Public Art Advisory Board for review and recommendation to the City Council. The item will be scheduled for the next available Public Art Advisory Board meeting. Following review by the Public Art Advisory Board, the item will be scheduled for City Council approval.

Applicants will be expected to provide a short presentation before the Public Art Advisory Board and/or City Council explaining the project, public art proposal, and location. Applicants should be prepared to answer any questions about the proposed art, artist, and/or project. It is strongly recommended that the project team and/or individuals knowledgeable about all aspects of the project and the artwork attend these meetings to avoid the item being tabled if additional information is required.

Option 2. *Contribute to Fund*

A contribution in the amount of 80% of 1% of the total construction costs for deposit to the art in public places fund must be paid in full prior to the issuance of a Certificate of Occupancy. For subdivision plats, the fee is due in full at the time of recording of the final plat.

Option 3. *On-site Artwork and Contribute to Fund*

Follow the procedures outlined in Options 1 and 2.

Option 4. *Alternative Equivalent Proposal*

The developer must submit an alternative equivalent proposal to the Planning and Zoning Director. The proposal shall be for the installation of freely accessible work of art on City's public right-of-way, on property owned by other public agencies, or on another property under the control or ownership of the developer. The proposal may seek the combination of the public art assessment associated with multiple projects into one larger work of art in lieu of several small works of art.

Enforcement

Unless an alternative deadline is established in a development order, or a time extension is granted by the Planning and Zoning Director, no Certificate of Occupancy or recording of a subdivision plat for a project subject to the public art assessment will be issued until the artwork is installed and/or the full art assessment has been paid to the city.



Public Art Assessment Application

Complete this application within ninety (90) days of the issuance of the first building permit or site work permit for a plat.

DATE: 04.01.26 BUILDING PERMIT NO.: _____

APPLICANT: Midway Glades Developers, LLC

OWNER (IF DIFFERENT FROM APPLICANT): _____

ADDRESS: 7807 Baymeadows Road East, Suite 205

[STREET]

Jacksonville, Florida 32256

[CITY / STATE / ZIP]

TEL NO.: 904.996.2485 CELL NO.: _____

EMAIL: info@greenpointllc.com

PROJECT NAME: Wylder Public Art PROJECT NUMBER: P

PROJECT ADDRESS: 5925 Wylder Parkway Port St. Lucie, Florida 24987

[STREET]

[CITY / STATE / ZIP]

CONSTRUCTION VALUE: \$ 1,638,014.29 DOLLAR AMOUNT OF PUBLIC ART REQUIRED: \$ 1,600,000.00

IF ESCROW: TOTAL ESCROW: \$ _____

PLEASE INDICATE WHICH PUBLIC ART CONTRIBUTION OPTION YOU HAVE CHOSEN.

1. On-site Artwork	<input type="checkbox"/>
2. Contribute to Fund	<input type="checkbox"/>
3. On-site Artwork and Contribute to Fund	<input type="checkbox"/>
4. Alternative Equivalent Proposal	<input checked="" type="checkbox"/>

I certify that the foregoing statements and information are true and that any submitted material, statements or plan designs are correct to the best of my knowledge.

Steve Sullivan
Applicant's Signature

03.24.26
Date



AFFIDAVIT

Midway Glades Developers, LLC (the Developer) hereby submits to the City of Port St. Lucie, Florida, its election of options with respect to the Art in Public Places Art Assessment application. Developer affirms and certifies that the ordinances, rules, policies and regulations of the City of Port St. Lucie Code of Ordinances will be observed, including but not limited to, Chapter 162 Art in Public Places.

It is further certified that the statements, exhibits or plans, and project cost data and affidavits submitted with respect to the Project and the art assessment are true and accurate to the best of the knowledge and belief of the Developer and the required public art, fee in lieu, or combination will be provided before issuance of Certificate of Occupancy for the Project.

The undersigned hereby swears or affirms that the matters contained herein are true and correct to the best knowledge of the Developer. The undersigned hereby swears or affirms that he/she is duly authorized by Developer to make this Affidavit and understands that s/he may be subject to penalty for perjury.

Signature: [Handwritten Signature]
Print Name: STEVEN J. SULLIVAN
Project Manager
Title

NOTARIZATION AS TO EXECUTION

STATE OF FLORIDA)
) ss
COUNTY OF Martin)

The foregoing instrument was acknowledged before me this 24 day of March, 2026, by Steven Sullivan who is [X] personally known to me or who has [] produced the following identification:

[Handwritten Signature]
Signature of Notary Public
Kathleen Anderson
Print Name of Notary Public
Notary Public, State of Florida
My Commission expires Jun 31, 2030



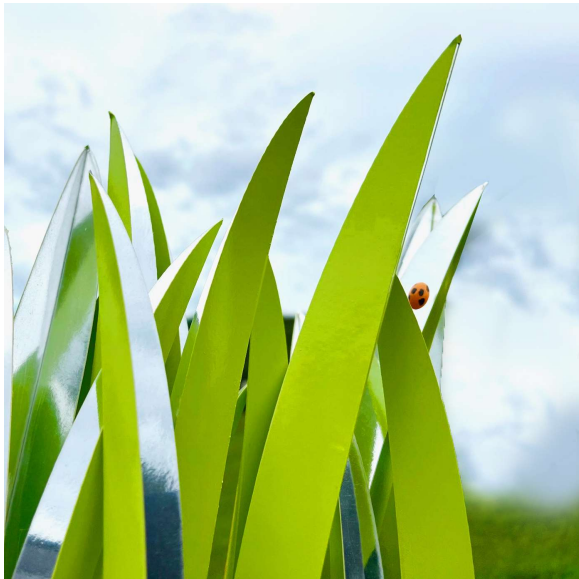

Maintenance Schedule

On an as-needed or annual basis:

1 - wash all surfaces with a mild solution of an automobile type soap and water,

2 - rinse with clean water and

3 - dry with a microfiber cloth to remove waterspots.

4 - Apply an automotive-type hydrophobic coating or carnuba wax to all surfaces of *Ladybug Hideaway* per the manufacturers direction; buff and polish with clean microfiber cloths, turning frequently to avoid wax buildup.

NOTE:

Mirror polished stainless steel surfaces are easily scratched.
Ensure that all cleaning cloths are free from dirt before using.

Ladybug Hideaway

WYLDER - Art In Public Places

City of Port St. Lucie, Florida

012224



MARK FULLER
FUNCTIONAL ARTS

1080 Gator Trail
West Palm Beach, FL 33409
561.707.4688
mtfuller.id8@gmail.com

Key / Location:

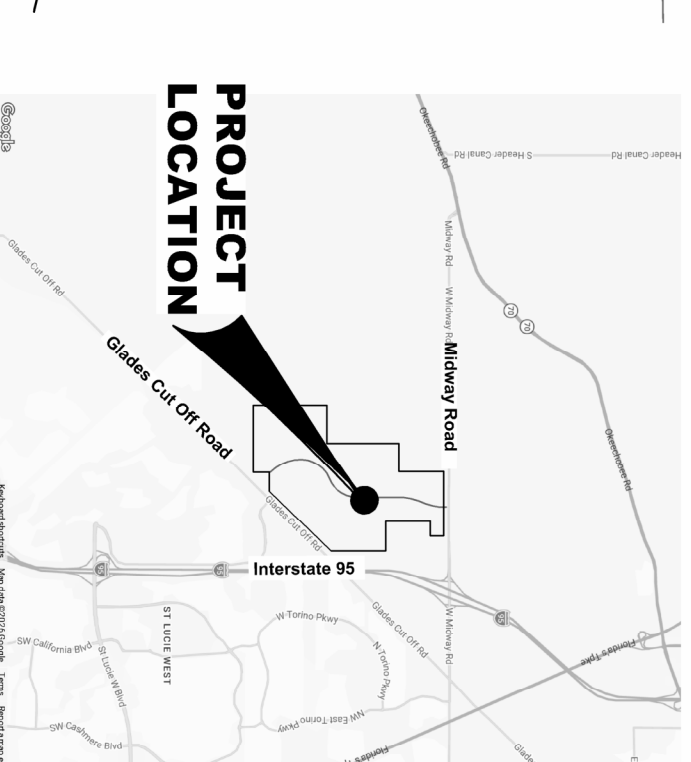

Project Team:

Client & Property Owner: Mowbray Grades Developer
7807 Baymeadows Road, Suite 205
Jacksonville, Florida 32256

Land Planner / Landscape Architect: Lucido & Associates
701 East Ocean Boulevard
Stuart, Florida 34994

Engineer: Kimley-Horn And Associates
445 24th Street, Suite 200
Vero Beach, Florida 32960



Surveyor: Geopoint
4450 West Eauagalle Blvd.
Suite 130 Melbourne, Florida 32934

Wylder
Art In Public Places
ADA Site Plan

Port St Lucie, Florida
P23-132
PSLUSD# xx-xxx-xxx

Date	By	Description
04.01.26	EMA	Submittal

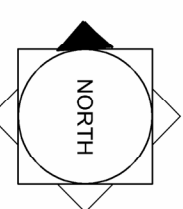
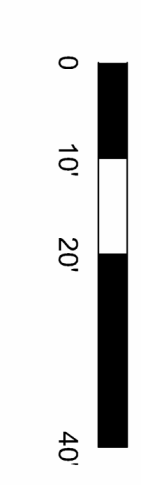
SCALE: 1" = 20'

Designer: EMA
Manager: SG
Project Number: 26-060
Municipal Number: P23-132
Computer File: 26-060 - Wylder AIPs At Commercial - Submittal Site Plan

SP2

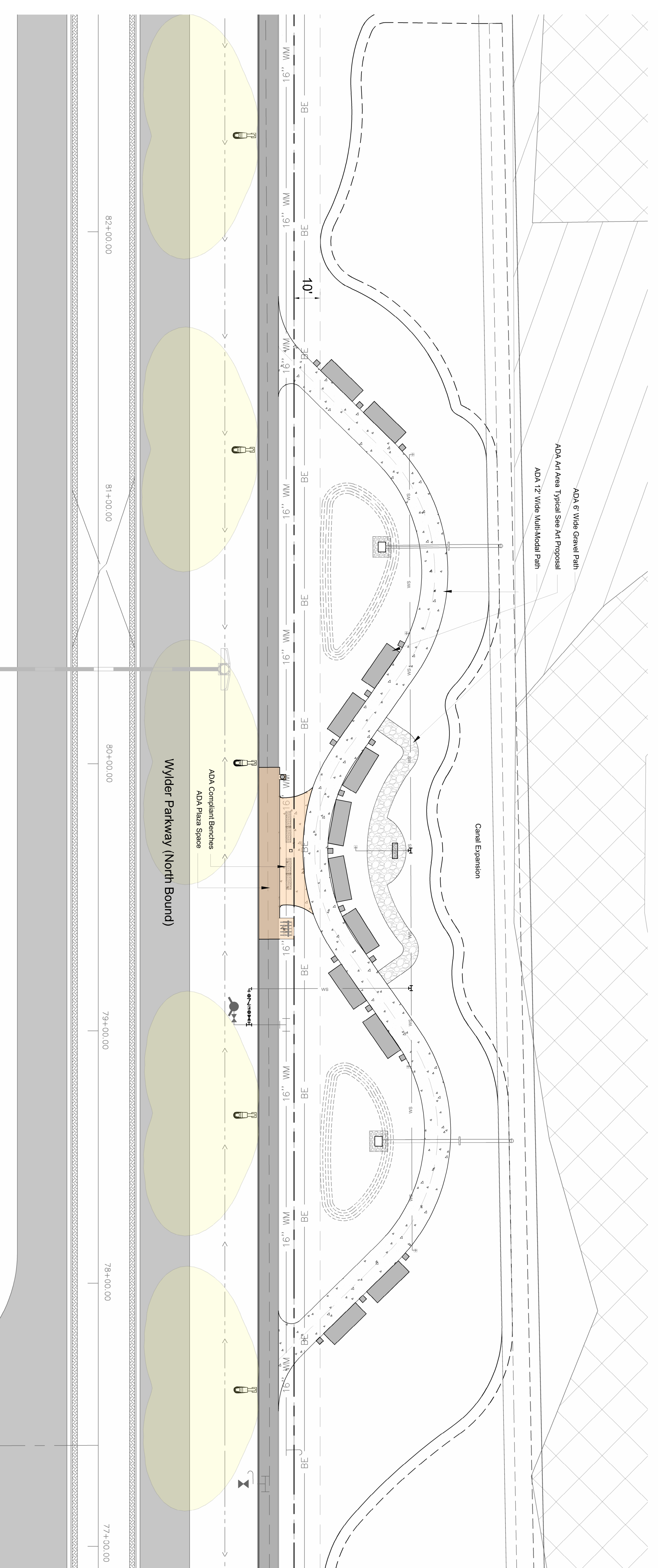

Art In Public Places Site Plan - Phase 1
Residential Public Art Requirement
Scale: 1" = 20'

© Lucido & Associates, Inc. All rights reserved. These documents and their contents are the property of Lucido & Associates. Any reproduction, storage, modification or use of these documents without the express written consent of Lucido & Associates is prohibited by law.

Wylder Projects Creditable Against Public Art Value:

Total Estimated Public Art Value: 1,618,316.29
 Total Wylder Project Required Public Art: 1,600,000.00

PUD:	Land Use:	Project Name:	Construction Cost:	1% of Construction Cost	Required Public Art Value:
LTC Ranch (West) Residential	Residential	POD 1 - Bristol	13,678,608.90	136,786.09	100,000.00
LTC Ranch (West) Residential	Residential	POD 2 - Bristol North	10,959,096.07	109,590.96	100,000.00
LTC Ranch (West) Residential	Residential	POD 4		0.00	100,000.00
LTC Ranch (West) Residential	Residential	POD 5 - Waverly	5,544,685.94	55,446.86	100,000.00
LTC Ranch (West) Residential	Residential	POD 6A - Four Seasons	10,174,185.15	101,741.85	100,000.00
LTC Ranch (West) Residential	Residential	POD 6B		0.00	100,000.00
LTC Ranch (West) Residential	Residential	POD 7 - Third Lake		0.00	100,000.00
LTC Ranch (West) Residential	Residential	POD 8A		0.00	100,000.00
LTC Ranch (West) Residential	Residential	POD 8B		0.00	100,000.00
LTC Ranch (West) Residential	Residential	POD 8C		0.00	100,000.00
LTC Ranch (West) Residential	Residential	POD 9 - Glynlea	28,550,846.00	285,508.46	100,000.00
LTC Ranch (West)	Commercial	Tract A		0.00	100,000.00
LTC Ranch (West)	Commercial	Tract B		0.00	100,000.00
LTC Ranch (West)	Commercial	Tract C		0.00	100,000.00
Founder Crossing East	Residential	Founders Crossing PUD		0.00	100,000.00
Founders Crossing West	Mixed Use	Founders Crossing PUD		0.00	100,000.00
Total			68,907,422.06	689,074.22	1,600,000.00

Four Seasons at Wylder Neighborhood Homeowners Association, Port St. Lucie, Florida
7807 Baymeadows Road East, Suite 205
Jacksonville, FL 32256

April 1, 2026

Planning & Zoning Department
City of Port St. Lucie
121 SW Port St. Lucie Boulevard, Building B
Port St. Lucie, FL 34984-5099

Re: LTC Ranch – Wylder Art In Public Places / Owner Authorization

To whom it may concern:

As owner of the property referenced above, please consider this correspondence as a formal authorization for Lucio & Associates to represent as applicant of the Four Seasons at Wylder Neighborhood Homeowners Association during governmental review process for the above noted project.

Thank you for your attention to this matter.

Sincerely,

DocuSigned by:
R. Austin Burr
608ECD929537491...

R. Austin Burr

President

Four Seasons at Wylder Neighborhood Homeowners Association

PREPARED BY AND
AFTER RECORDING RETURN TO:

Foley & Lardner LLP
1 Independent Drive | Suite 1300
Jacksonville, FL 32202
Attn: N. Vincent Pulignano III, Esq.

SPECIAL WARRANTY DEED

THIS SPECIAL WARRANTY DEED is made effective February 2, 2024, by **MIDWAY GLADES DEVELOPERS**, a Delaware limited liability company (“**Grantor**”), whose mailing address is 7807 Baymeadows Road East, Suite 205, Jacksonville, Florida 32256, in favor of **FOUR SEASONS AT WYLDER NEIGHBORHOOD ASSOCIATION, INC.**, a Florida not-for-profit corporation, whose address is 7807 Baymeadows Road East, Suite 205, Jacksonville, Florida 32256 (“**Grantee**”).

That the Grantor, for and in consideration of the sum of Ten Dollars (\$10.00) and other good and valuable consideration, to it in hand paid, the receipt whereof is hereby acknowledged, by these presents does grant, bargain, sell, alien, remise, release, convey and confirm unto the Grantee, its successors and assigns forever, all that certain parcel of land lying and being in St. Lucie County, Florida, as more particularly described in the Exhibit “A” annexed hereto and by this reference made a part hereof.

TOGETHER WITH all the tenements, hereditaments, and appurtenances thereto belonging or in anywise appertaining.

SUBJECT TO real estate taxes and assessments for 2024 and all subsequent years, and all easements, covenants, conditions and restrictions of record, but without reimposing same.

TO HAVE AND TO HOLD the above described premises, with the appurtenances, unto the said Grantee, its successors and assigns, in fee simple forever.

And the Grantor does specially warrant the title to said land subject to the matters referred to above and will defend the same against the lawful claims of all persons claiming by, through or under the Grantor, but not otherwise.

[REMAINDER OF PAGE LEFT INTENTIONALLY BLANK]
[SIGNATURE PAGE TO FOLLOW]

IN WITNESS WHEREOF, Grantor has executed this Special Warranty Deed as of the day and year first above written.

Signed in the presence of:

Print Name: Brennan Dwyer

Address: 864 SE Becker Rd
Port St. Lucie, FL 34984

Print Name: Luke Rector

Address: 864 SE Becker Rd
Port St. Lucie, FL 34984

GRANTOR:

MIDWAY GLADES DEVELOPERS, LLC,
a Delaware limited liability company,

By: R. Austin Burr

Name: R. Austin Burr

Title: Vice President

STATE OF FLORIDA

COUNTY OF ST LUCIE

The foregoing instrument was acknowledged before me, by means of physical presence or online notarization, this 20th day of February, 2024, by R. Austin Burr, as Vice President of MIDWAY GLADES DEVELOPERS, LLC, a Delaware limited liability company, on behalf of the entity. He is personally known to me or has produced _____, as identification.

(NOTARY SEAL)

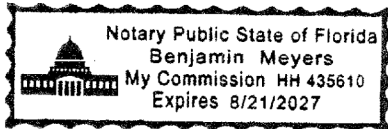

Benjamin Meyers
NOTARY PUBLIC

Notary Public, State of Florida

Print Name: Benjamin Meyers

My commission expires: 8/21/2027

EXHIBIT A

LEGAL DESCRIPTION

Tracts R, O-1, O-2, O-3, O-4, O-5, O-6, and Amenity Center Tract, of LTC RANCH WEST POD 6A PHASE 1, according to the plat thereof, as recorded in Plat Book 120, Pages 1 through 18, inclusive, of the Public Records of St. Lucie County, Florida.

Official Copy

Property Identification

Site Address: TBD
 Sec/Town/Range: 09/36S/39E
 Parcel ID: **3303-500-0001-000-1**
 Jurisdiction: Port Saint Lucie
 Land Use Code: 0900 - ResCommonElemnt
 Account #: **201537**
 Map ID: [33/10S](#)
 Zoning: Planned Un



Legal Description

LTC RANCH WEST POD 6A PHASE 1 (PB 120-1) TRACT O-1 (7.877 AC - 343,101 SF) (AS PER PLAT DEDICATION DATED 9/14/23)

Total Areas

Finished/Under Air (SF): 0
 Gross Sketched Area (SF): 0
 Land Size (acres): 7.88
 Land Size (SF): 343,101

Map



Building Wind Speed

Occupancy Category	I	II	III & IV
Speed	140	150	160

[Sources/links:](#)

State of Florida, Vantor

Powered by Esri

Ownership

Four Seasons at Wylder Neighborhood Association Inc
 7807 Baymeadows Rd E Ste 205
 Jacksonville, FL 32256-9666

Current Values

Just/Market value: \$0
 Assessed value: \$0
 Exemption value: \$0
 Taxable value: \$0

Important

Property taxes are subject to change upon change of ownership.

- Past taxes are not a reliable projection of future taxes.
- The sale of a property will prompt the removal of all exemptions, assessment caps, and special classifications.

Links

Taxes for this parcel: [SLC Tax Collector's Office](#)

Download TRIM for this Parcel: [Download PDF](#)

[File for homestead exemptions.](#)

[View associated Tax Map.](#)

[Report Homestead Fraud on this parcel.](#)

Sale History

Date	Book/Page	Sale Code	Deed	Grantor	Price
Jan 30, 2024	5103/1650	0311	SPWD	Four Seasons at Wylder Neighborhood Association Inc	\$100

Special Features and Yard Items

Type	Qty	Units	Year Blt
------	-----	-------	----------

Values Breakdown

2025 ▾

Building	\$0
SFYI	\$0

Land	\$0
Just/Market	\$0
Ag Credit	\$0
Save Our Homes or 10% Cap	\$0
Assessed	\$0
Exemptions	\$0
Taxable	\$0

Current Year Exemption Value Breakdown

Tax Year	Grant Year	Description	Amount
----------	------------	-------------	--------

Important

Property taxes are subject to change upon change of ownership.

- Past taxes are not a reliable projection of future taxes.
- The sale of a property will prompt the removal of all exemptions, assessment caps, and special classifications.

Current Year Special Assessment Breakdown

Start Year	Units	Description	Amount
2024	0	LTC Ranch West CDD	\$0.00
2026	0	PSL Stormwater LTC Ranch West CDD	\$

This does not necessarily represent the total Special Assessments that could be charged against this property.

The total amount charged for special assessments is reflected on the most current tax statement and information is available with the [SLC Tax Collector's Office](#)

Permits

Number	Issue Date	Description	Amount	Fees
2428036	Jul 24, 2024		\$85,000	\$1,544

Notice: This does not necessarily represent all the permits for this property.

Click the following link to check for additional permit data in **Port Saint Lucie**

All information is believed to be correct at this time, but is subject to change and is provided without any warranty.

© Copyright 2026 Saint Lucie County Property Appraiser. All rights reserved.



Agenda Summary

2026-453

Agenda Date: 5/18/2026

Agenda Item No.: 6.d

Placement: New Business

Action Requested: Discussion

Status Update on the Installation of Sculptures for the Two Roundabouts Located on Paar Drive.

Submitted By: Bethany Grubbs, AICP, Senior Planner/Public Art Program

Strategic Plan Link: The City's Goal to enjoy culture, nature and fun activities.

Executive Summary (General Business): Due to reduced revenue projections, roundabout projects are unlikely to be included in the upcoming CIP budget. As a result, public-art contracts for the Paar roundabouts are paused until the budget is finalized in July, since funding for these projects is uncertain and not expected to be approved.

Presentation Information: N/A

Staff Recommendation: N/A

Background: In January, the Public Art Advisory Board (PAAB) voted to move forward with artist recommendations to commission sculptures for two new roundabouts at Paar & Darwin and Paar & Savona for installation in Spring 2027.

Issues/Analysis: The projected reduction in revenues has affected the progression of several roundabout projects that were initially anticipated to include public art. The Public Works Capital Improvement Plan (CIP) budget was presented to the City Council on April 20, with formal adoption scheduled for the Summer Workshop. At this time, the budget does not include any roundabout projects. Consequently, the contracts related to the selection of artwork for CIP-funded roundabouts have been placed on hold for the foreseeable future, or at least until the budget is finalized in July.

Outside of what is noted above, we also have Village Green Dr. on the horizon; however, we will not know whether we have secured a construction grant until January 2027.

Financial Information: N/A

Special Consideration: The CIP is a five-year planning document, meaning funding is evaluated over a multi-year period. Although roundabout projects are not expected to be included in the upcoming CIP budget, other revenue sources may become available during that time.

Location of Project: Paar & Darwin and Paar & Savona

Attachments:

1. Draft CIP Budget

NOTE: All of the listed items in the "Attachment" section above are in the custody of the City Clerk. Any item(s) not provided in packets are available upon request from the City Clerk.

Internal Reference Number: N/A

304 - ROAD & BRIDGE CIP					
Project/Description	FY 2026-27	FY 2027-28	FY 2028-29	FY 2029-30	FY 2030-31
Land Acquisition	\$ 200,000	\$ 200,000	\$ 200,000	\$ 200,000	\$ 200,000
Citywide Traffic Calming	-	250,000	250,000	250,000	250,000
New Sidewalks Citywide	-	1,000,000	1,000,000	1,000,000	1,000,000
Project Management Costs for Capital Improvements	-	200,000	200,000	200,000	200,000
Citywide ADA Improvements - Signals Various Locations & APS	150,000	150,000	150,000	150,000	150,000
Gatlin/Savona Phase II Widening (Wellington to SW Dalton Cir)	11,500,000	-	-	-	-

1

Project/Description	FY 2026-27	FY 2027-28	FY 2028-29	FY 2029-30	FY 2030-31
Marshall Parkway & I-95 Interchange PD&E Study	2,000,000	-	-	-	-
Port St. Lucie Blvd. South Segment 1 (Becker to Paar)	27,300,000	-	-	-	-
Tradition & Village Mobility Improvements	2,500,000	-	-	-	-
Pavement Condition and Asset Inventory Survey	-	500,000	-	-	500,000
Southbend Blvd. Widening Improvements Corridor Program	-	-	-	-	1,200,000
Citywide Annual Resurfacing Program	2,459,711	2,553,600	2,599,367	2,697,049	1,496,684
Citywide Contract Repair/Improvements of Sidewalks	500,000	500,000	550,000	550,000	650,000
SW Glenwood Drive Roadway Reconstruction	1,700,000	-	-	-	-
Total Road & Bridge CIP	\$ 48,309,711	\$ 5,353,600	\$ 4,949,367	\$ 5,047,049	\$ 5,646,684

310 - HALF CENT SALES TAX CIP					
Project/Description	FY 2026-27	FY 2027-28	FY 2028-29	FY 2029-30	FY 2030-31
California Widening	\$ 6,050,000	\$ -	\$ -	\$ -	\$ -
Citywide Annual Resurfacing Program	1,700,000	4,600,000	2,050,000	-	-
Citywide Sidewalk Improvements	1,100,000	1,100,000	960,000	-	-
Gatlin Blvd Resurfacing	4,350,000	-	-	-	-
California Widening	-	7,000,000	5,000,000	-	-
St. Lucie West Blvd. Widening Peacock to Cashmere	-	-	-	8,600,000	80,000,000
Total Half Cent Sales Tax CIP	\$ 13,200,000	\$ 12,700,000	\$ 8,010,000	\$ 8,600,000	\$ 80,000,000

Four Seasons at Wylder Neighborhood Homeowners Association, Port St. Lucie, Florida
7807 Baymeadows Road East, Suite 205
Jacksonville, FL 32256

April 1, 2026

Planning & Zoning Department
City of Port St. Lucie
121 SW Port St. Lucie Boulevard, Building B
Port St. Lucie, FL 34984-5099

Re: LTC Ranch – Wylder Art In Public Places / Owner Authorization

To whom it may concern:

As owner of the property referenced above, please consider this correspondence as a formal authorization for Lucio & Associates to represent as applicant of the Four Seasons at Wylder Neighborhood Homeowners Association during governmental review process for the above noted project.

Thank you for your attention to this matter.

Sincerely,

DocuSigned by:
R. Austin Burr
608ECD929537491...

R. Austin Burr

President

Four Seasons at Wylder Neighborhood Homeowners Association