

Street Trees Required:
 3,705 LF of Roadway; Street Trees 50' O.C. = 74 Street Trees (North & South Side)
 Street Trees Provided (See Note 5 below):
 75 Street Trees

Index of Drawings:

Cover Sheet	CV
Plant List	CV
Landscape Plan	LA-1 - LA-4
Details	LA-5
Specifications	LA-6

Key / Location:

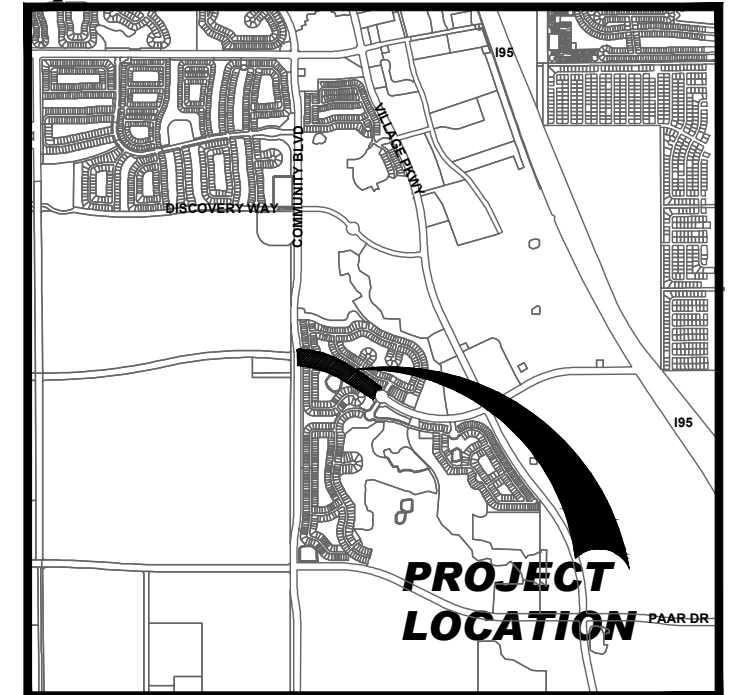

N.T.S.

Project Team:



Client & Property Owner: Mattamy Homes, LLC
 1500 Gateway Blvd, Suite 220
 Boynton Beach, Florida 33426

Land Planner / Landscape Architect: Lucido & Associates
 701 East Ocean Boulevard
 Stuart, Florida 34994

Engineer: Culpepper and Terpening, Inc.
 2980 South 25th Street
 Fort Pierce, FL 34981

Surveyor: Cauffield & Wheeler, Inc.
 410 S.E. Port St. Lucie Blvd.
 Port St. Lucie, Florida 34984

**Mattamy Homes
 Marshall Parkway**

Port St. Lucie, Florida

**Median and Street
 Tree Landscape Plan**

Date	By	Description
03.29.23	SAW	Review

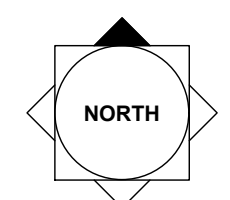

SCALE: 1" = 80'
 0 40' 80' 160'



REG. # 1018
 Thomas P. Lucido

Designer	SAW	Sheet
Manager	SG	
Project Number	20-276.40	CV
Municipal Number	P	
Computer File	20-276.40 Marshall Parkway Landscape.dv	

© Copyright Lucido & Associates. These documents and their contents are the property of Lucido & Associates. Any reproductions, revisions, modifications or use of these documents without the express written consent of Lucido & Associates is prohibited by law.

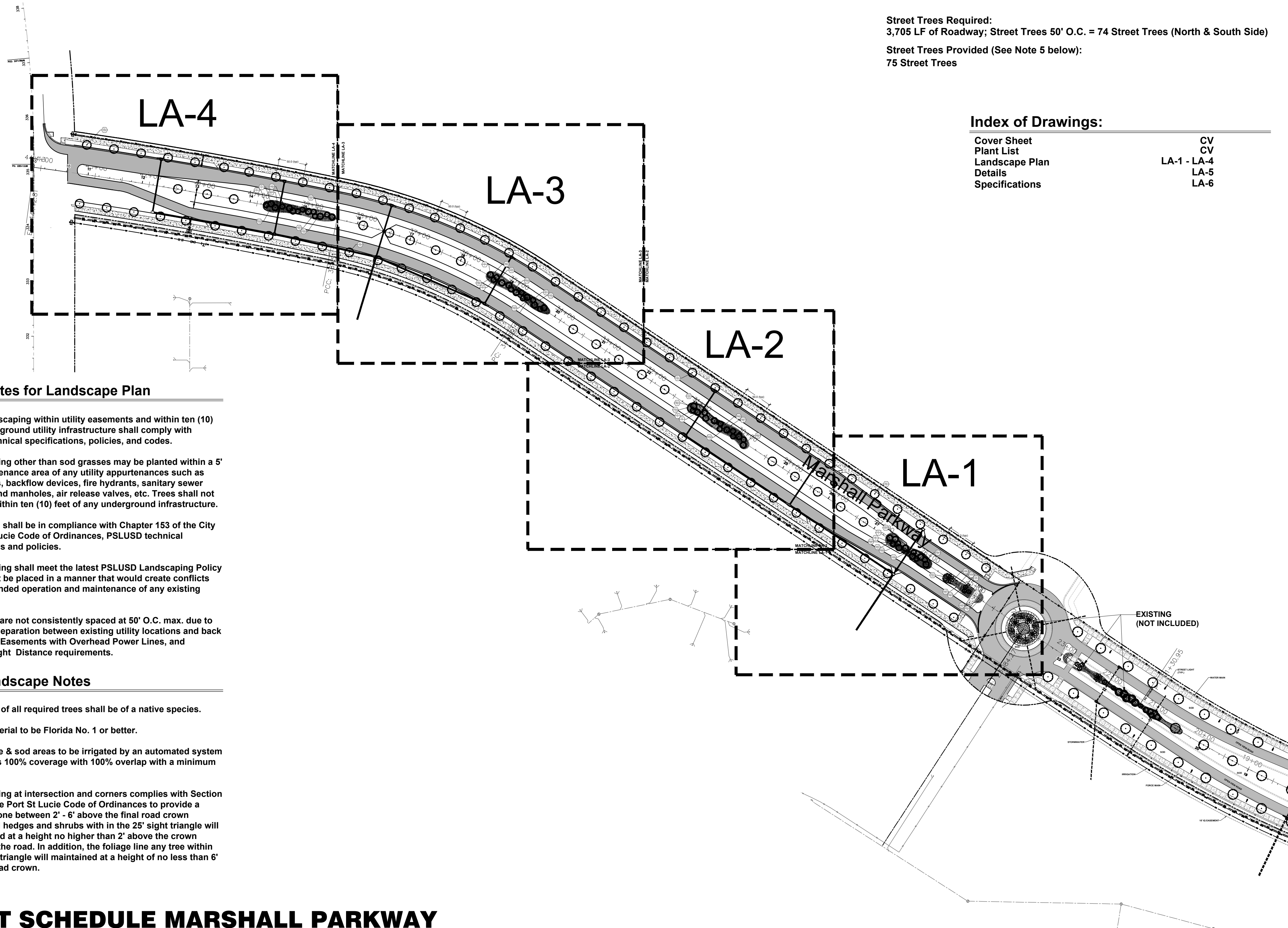

PSLUSD Notes for Landscape Plan

- All new landscaping within utility easements and within ten (10) feet of underground utility infrastructure shall comply with PSLUSD technical specifications, policies, and codes.
- No landscaping other than sod grasses may be planted within a 5' radius maintenance area of any utility appurtenances such as water meters, backflow devices, fire hydrants, sanitary sewer cleanouts, and manholes, air release valves, etc. Trees shall not be planted within ten (10) feet of any underground infrastructure.
- Landscaping shall be in compliance with Chapter 153 of the City Of Port St. Lucie Code of Ordinances, PSLUSD technical specifications and policies.
- All landscaping shall meet the latest PSLUSD Landscaping Policy and shall not be placed in a manner that would create conflicts with the intended operation and maintenance of any existing utility.
- Street Trees are not consistently spaced at 50' O.C. max. due to insufficient separation between existing utility locations and back of curb, FPL Easements with Overhead Power Lines, and Vehicular Sight Distance requirements.

General Landscape Notes

- At least 50% of all required trees shall be of a native species.
- All plant material to be Florida No. 1 or better.
- All landscape & sod areas to be irrigated by an automated system that provides 100% coverage with 100% overlap with a minimum d.u. of .70.
- All landscaping at intersection and corners complies with Section 158.204 of the Port St. Lucie Code of Ordinances to provide a clear sight zone between 2' - 6' above the final road crown elevation. All hedges and shrubs within the 25' sight triangle will be maintained at a height no higher than 2' above the crown elevation of the road. In addition, the foliage line any tree within the 25' sight triangle will be maintained at a height of no less than 6' above the road crown.

PLANT SCHEDULE MARSHALL PARKWAY

TREES	QTY	BOTANICAL NAME	COMMON NAME	CONTAINER	HEIGHT	WIDTH	NOTES	NATIVE	CALIPER
PD	1	Phoenix dactylifera `Medjool`	Medjool Date Palm	FG	16' CT		FH, SP, Straight, Classic Cut	Non-native	
PE	28	Pinus elliotti	Slash Pine	FG	12' HT	6' W			
QV	93	Quercus virginiana	Southern Live Oak	65G	14' HT	7' SPR	F, SP	Native	4" Caliper
SP	26	Sabal palmetto	Sabal Palm	FG	10' - 18' CT		HVY CAL, SP	Native	
SHRUBS	QTY	BOTANICAL NAME	COMMON NAME	CONTAINER	HEIGHT	WIDTH	NOTES	NATIVE	
GAG	46	Galphimia glauca	Thryalis	3G	24" HT	18"W	F	Non-native	
RL	48	Rondeletia leucophylla	Panama Rose	3G	24" OA		F	Non-native	
SUU	56	Stachytarpheta urticifolia	Blue Porterweed	3G	24" OA		F	Native	
SHRUB AREAS	QTY	BOTANICAL NAME	COMMON NAME	CONTAINER	HEIGHT	WIDTH	NOTES	NATIVE	
BIH	282	Bougainvillea x 'Helen Johnson'	Helen Johnson Compact Bougainvillea	3G	18" OA		F	Non-native	24" o.c.
GRASSES	QTY	BOTANICAL NAME	COMMON NAME	CONTAINER	HEIGHT	WIDTH	NOTES	NATIVE	
MUH	722	Muhlenbergia capillaris	Pink Muhly	3G	18" OA		F		24" o.c.
PEN	261	Pennisetum setaceum `White`	White Fountain Grass	3G	24" OA		F		36" o.c.
GROUND COVERS	QTY	BOTANICAL NAME	COMMON NAME	CONTAINER	HEIGHT	WIDTH	NOTES	NATIVE	
ILS	566	Ilex vomitoria `Stokes Dwarf`	Dwarf Yaupon	1G	12" HT	12"W	Full	Native	18" o.c.
JUP	346	Juniperus chinensis `Parsonii`	Parsonii Juniper	1G	10" HT	15" SPR	Full	Non-native	24" o.c.

Key / Location:

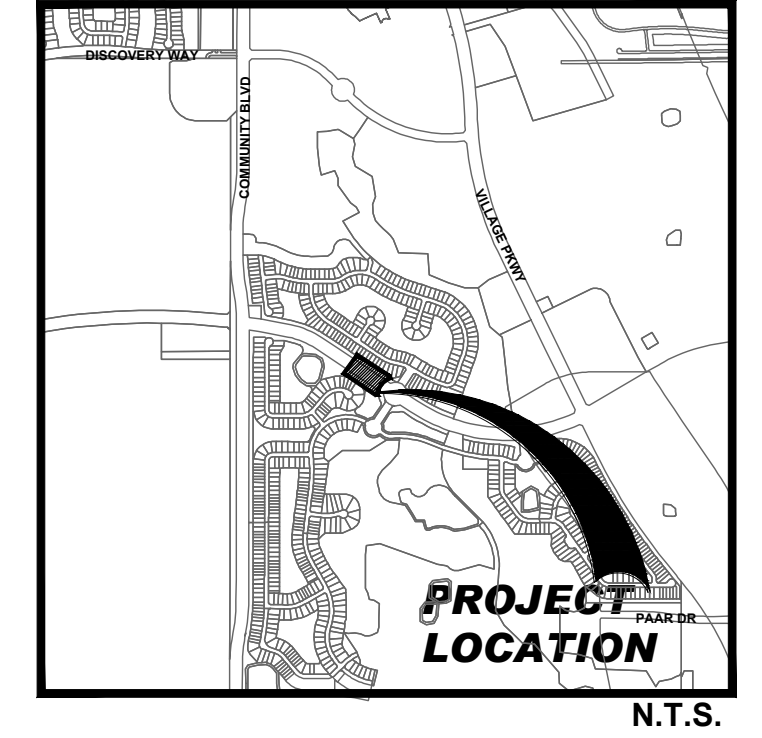

Project Team:



Client & Property Owner: Mattamy Homes, LLC
 1500 Gateway Blvd., Suite 220
 Boynton Beach, Florida 33426

Land Planner / Landscape Architect: Lucido & Associates
 701 East Ocean Boulevard
 Stuart, Florida 34994

Engineer: Culpepper and Terpening, Inc.
 2880 South 25th Street
 Fort Pierce, FL 34981

Surveyor: Cauffield & Wheeler, Inc.
 410 S.E. Port St. Lucie Blvd.
 Port St. Lucie, Florida 34984

**Mattamy Homes
 Marshall Parkway**

Port St. Lucie, Florida

**Median and Street
 Tree Landscape Plan**

Date	By	Description
03.29.23	SAW	Review

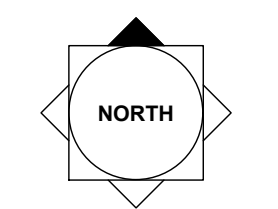

SCALE: 1" = 20'
 0 10' 20' 40'

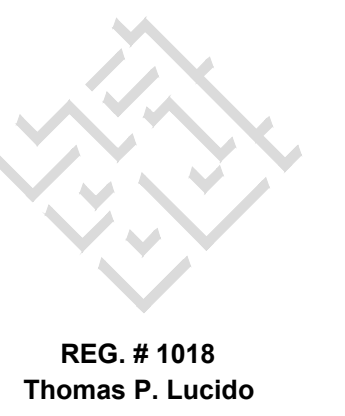

Designer: SAW **Sheet:** **LA-1**
Manager: SG
Project Number: 20-276.40
Municipal Number: P
Computer File: 20-276.40 Marshall Parkway Landscape.dv

© Copyright Lucido & Associates. These documents and their contents are the property of Lucido & Associates. Any reproductions, revisions, modifications or use of these documents without the express written consent of Lucido & Associates is prohibited by law.

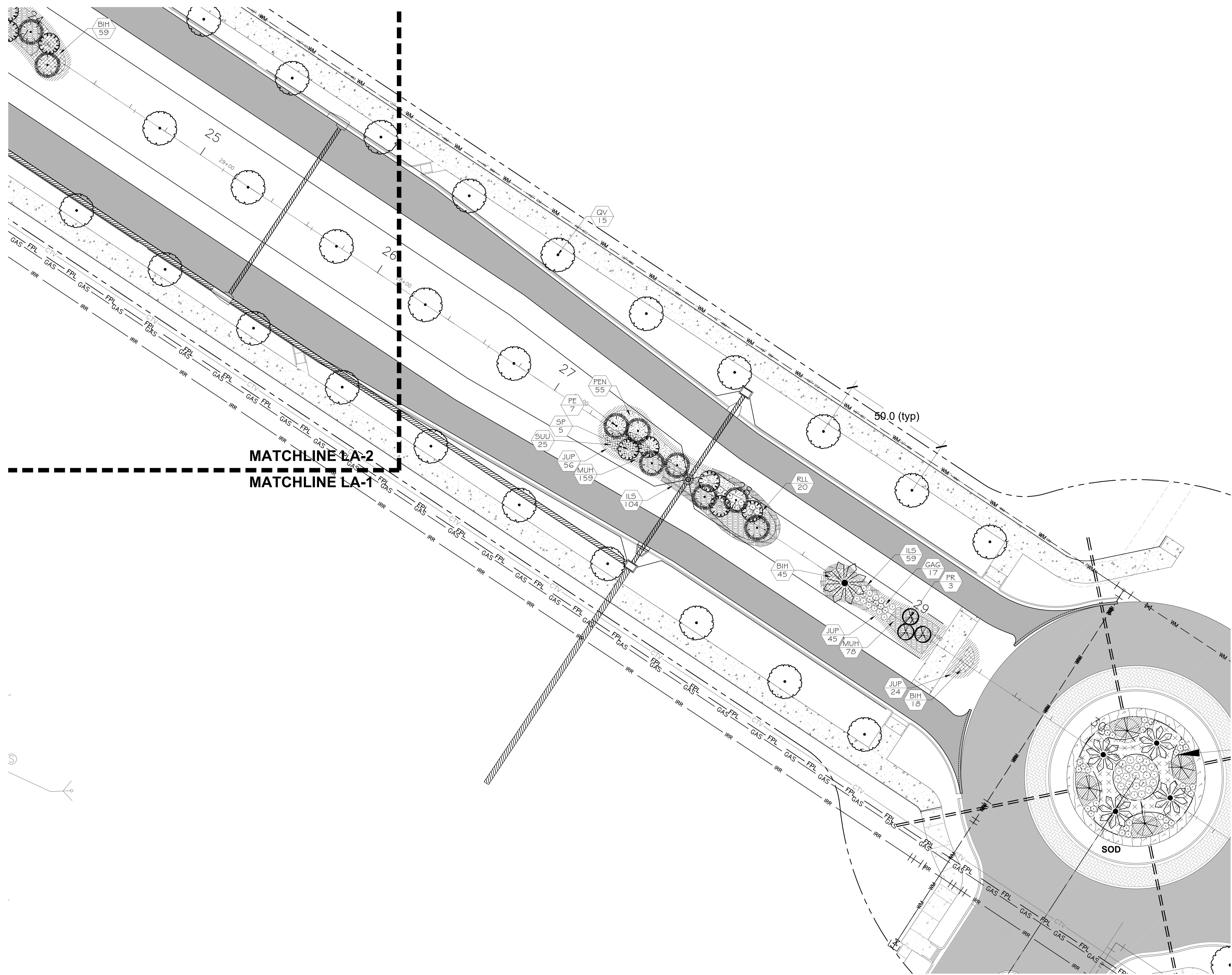

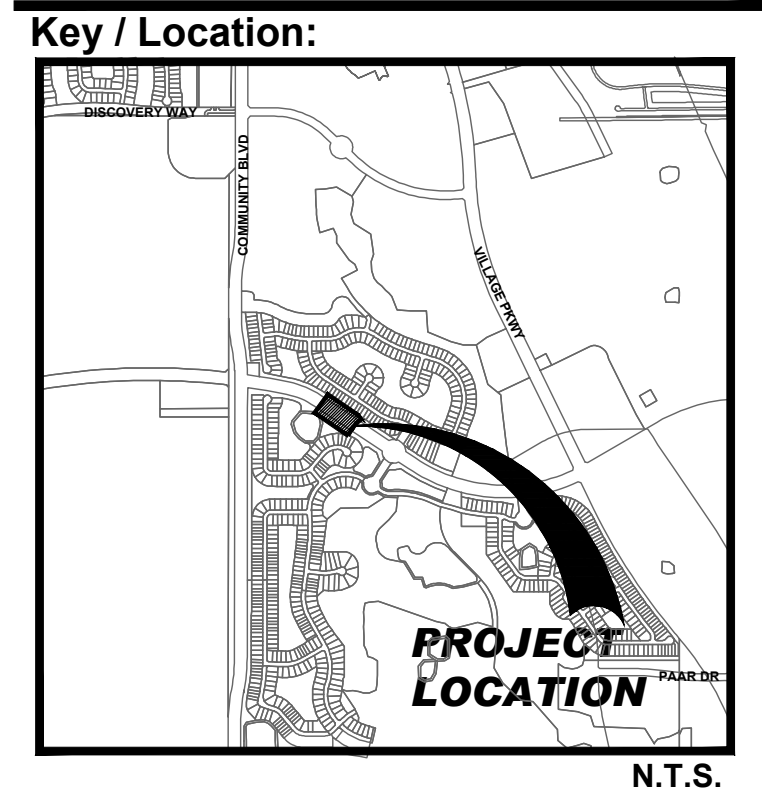

Project Team:



Client & Property Owner: Mattamy Homes, LLC
 1500 Gateway Blvd., Suite 220
 Boynton Beach, Florida 33426

Land Planner / Landscape Architect: Lucido & Associates
 701 East Ocean Boulevard
 Stuart, Florida 34994

Engineer: Culpesper and Terpening, Inc.
 2980 South 26th Street
 Fort Pierce, FL 34981

Surveyor: Cauffield & Wheeler, Inc.
 410 S.E. Port St. Lucie Blvd.
 Port St. Lucie, Florida 34984

Mattamy Homes Marshall Parkway

Port St. Lucie, Florida
**Median and Street
 Tree Landscape Plan**

Date	By	Description
03.29.23	SAW	Review

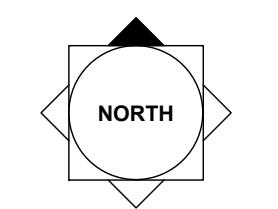

SCALE: 1" = 20'
 0 10' 20' 40'

 REG. # 1018
 Thomas P. Lucido

Designer: SAW **Sheet:**
Manager: SG
Project Number: 20-276.40
Municipal Number: P
Computer File: 20-276.40 Marshall Parkway Landscape.dv

LA-2

© Copyright Lucido & Associates. These documents and their contents are the property of Lucido & Associates. Any reproductions, revisions, modifications or use of these documents without the express written consent of Lucido & Associates is prohibited by law.

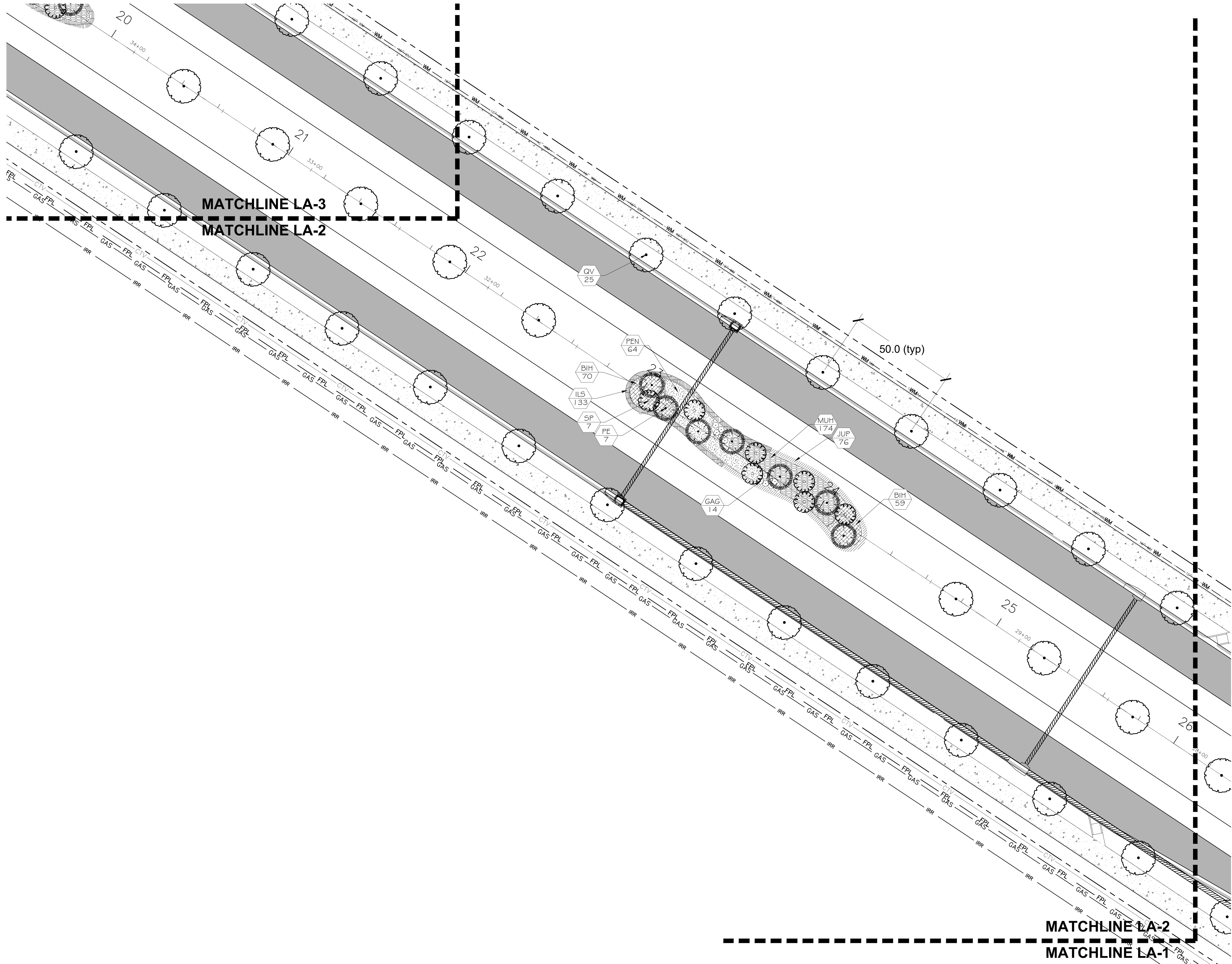

MATCHLINE LA-2
MATCHLINE LA-1

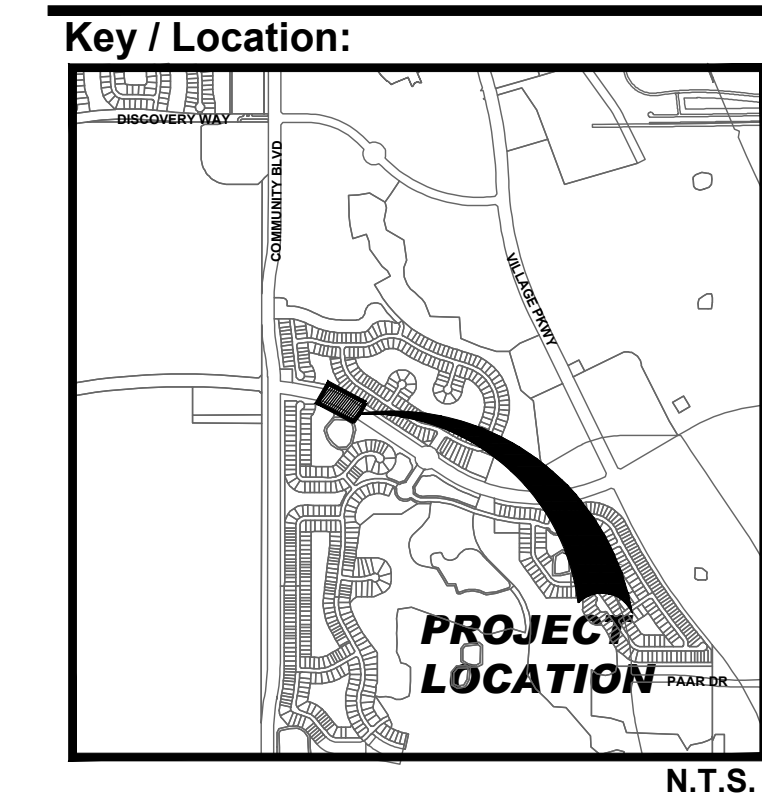

Project Team:



Client & Property Owner: Mattamy Homes, LLC
 1500 Gateway Blvd, Suite 220
 Boynton Beach, Florida 33426

Land Planner / Landscape Architect: Lucido & Associates
 701 East Ocean Boulevard
 Stuart, Florida 34994

Engineer: Culpepper and Terpinia, Inc.
 2980 South 25th Street
 Fort Pierce, FL 34981

Surveyor: Cauffield & Wheeler, Inc.
 410 S.E. Port St. Lucie Blvd.
 Port St. Lucie, Florida 34984

**Mattamy Homes
Marshall Parkway**

Port St. Lucie, Florida

**Median and Street
Tree Landscape Plan**

Date	By	Description
03.29.23	SAW	Review

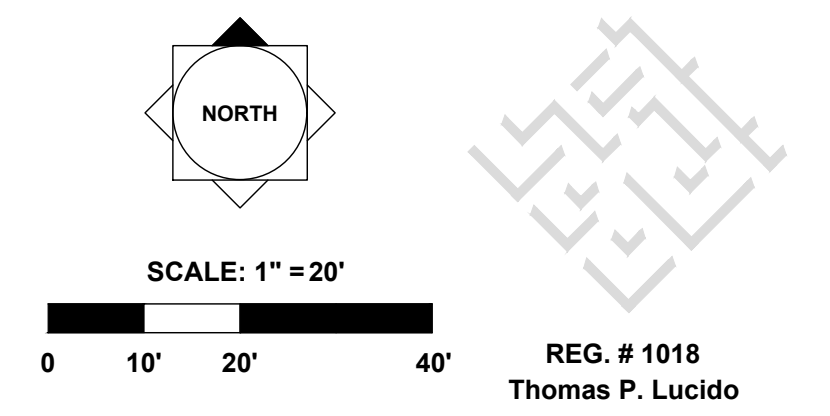

Designer	SAW	Sheet
Manager	SG	LA-3
Project Number	20-276.40	
Municipal Number	P	
Computer File	20-276.40 Marshall Parkway Landscape.dv	

© Copyright Lucido & Associates. These documents and their contents are the property of Lucido & Associates. Any reproductions, revisions, modifications or use of these documents without the express written consent of Lucido & Associates is prohibited by law.

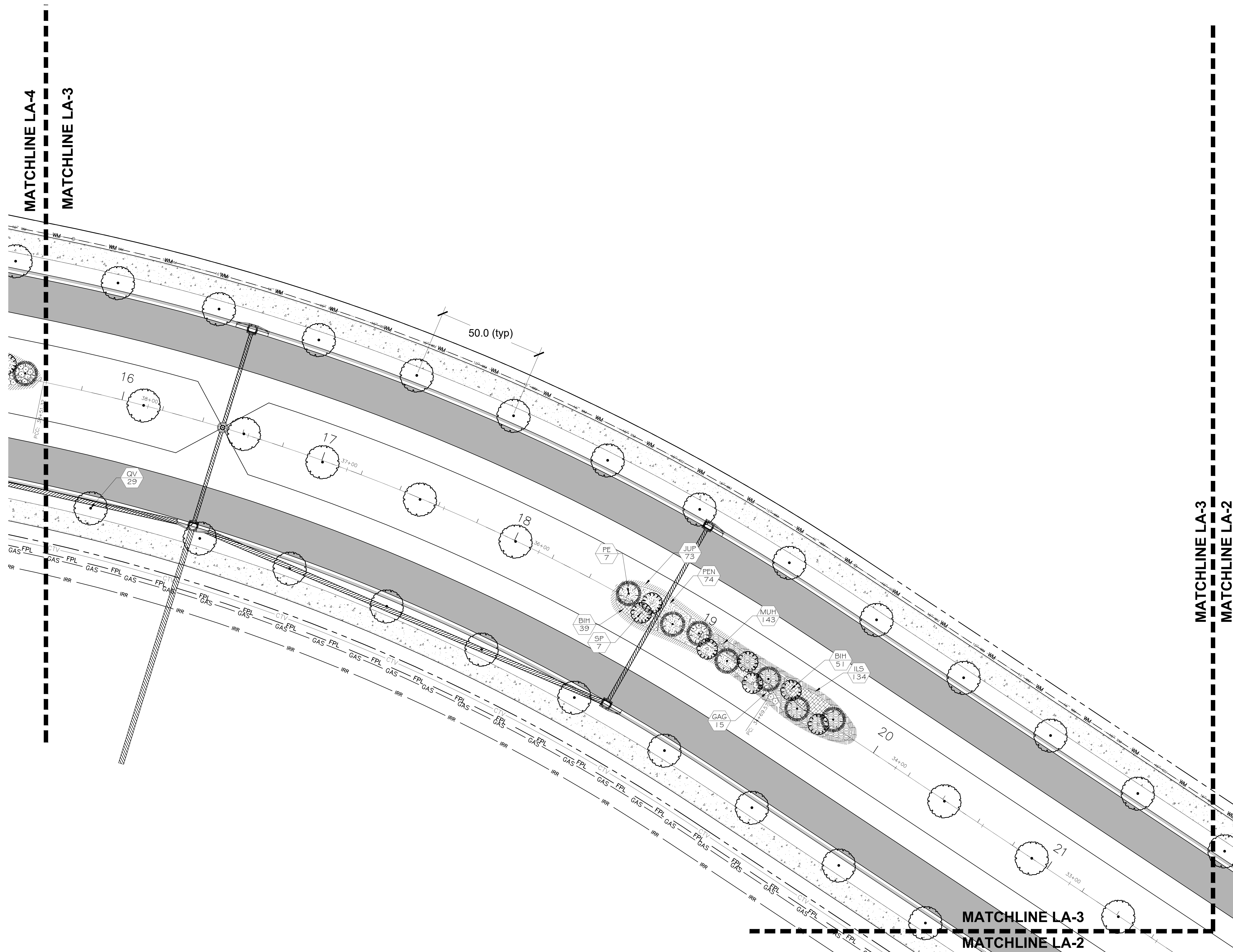

MATCHLINE LA-4
MATCHLINE LA-3

MATCHLINE LA-3
MATCHLINE LA-2

MATCHLINE LA-3
MATCHLINE LA-2

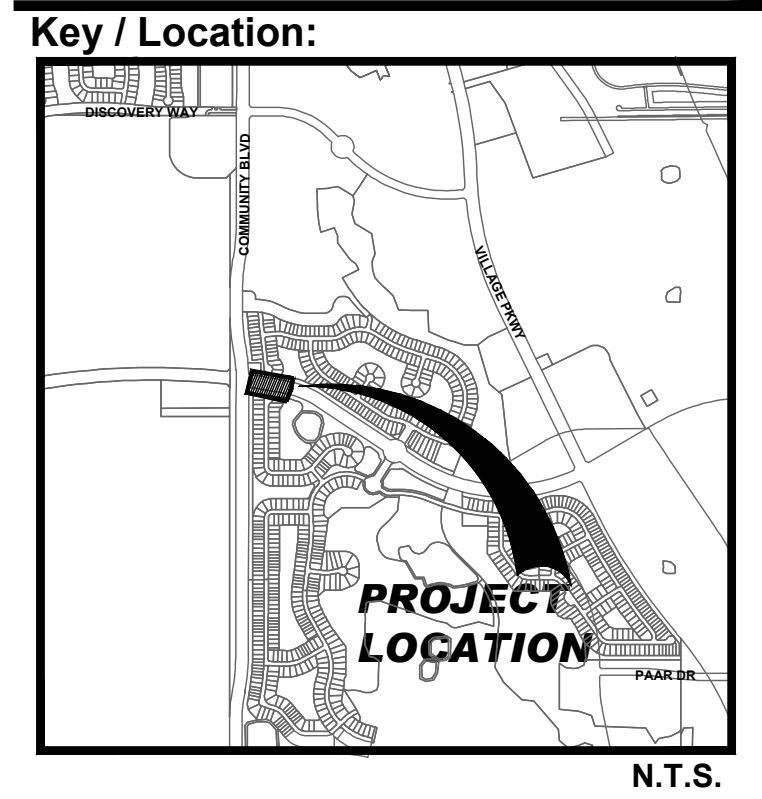

Project Team:

mattamyHOMES

Client & Property Owner: Mattamy Homes, LLC
 1500 Gateway Blvd., Suite 220
 Boynton Beach, Florida 33426

Land Planner / Landscape Architect: Lucido & Associates
 701 East Ocean Boulevard
 Stuart, Florida 34994

Engineer: Culpepper and Terpening, Inc.
 2908 South 25th Street
 Fort Pierce, FL 34981

Surveyor: Cauffield & Wheeler, Inc.
 410 S.E. Port St. Lucie Blvd.
 Port St. Lucie, Florida 34984

**Mattamy Homes
 Marshall Parkway**

Port St. Lucie, Florida

**Median and Street
 Tree Landscape Plan**

Date	By	Description
03.29.23	SAW	Review

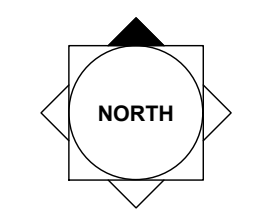

SCALE: 1" = 20'

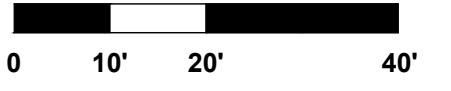

REG. # 1018
 Thomas P. Lucido

Designer SAW Sheet
 Manager SG
 Project Number 20-276.40
 Municipal Number P
 Computer File 20-276.40 Marshall Parkway Landscape.dv

LA-4

© Copyright Lucido & Associates. These documents and their contents are the property of Lucido & Associates. Any reproductions, revisions, modifications or use of these documents without the express written consent of Lucido & Associates is prohibited by law.

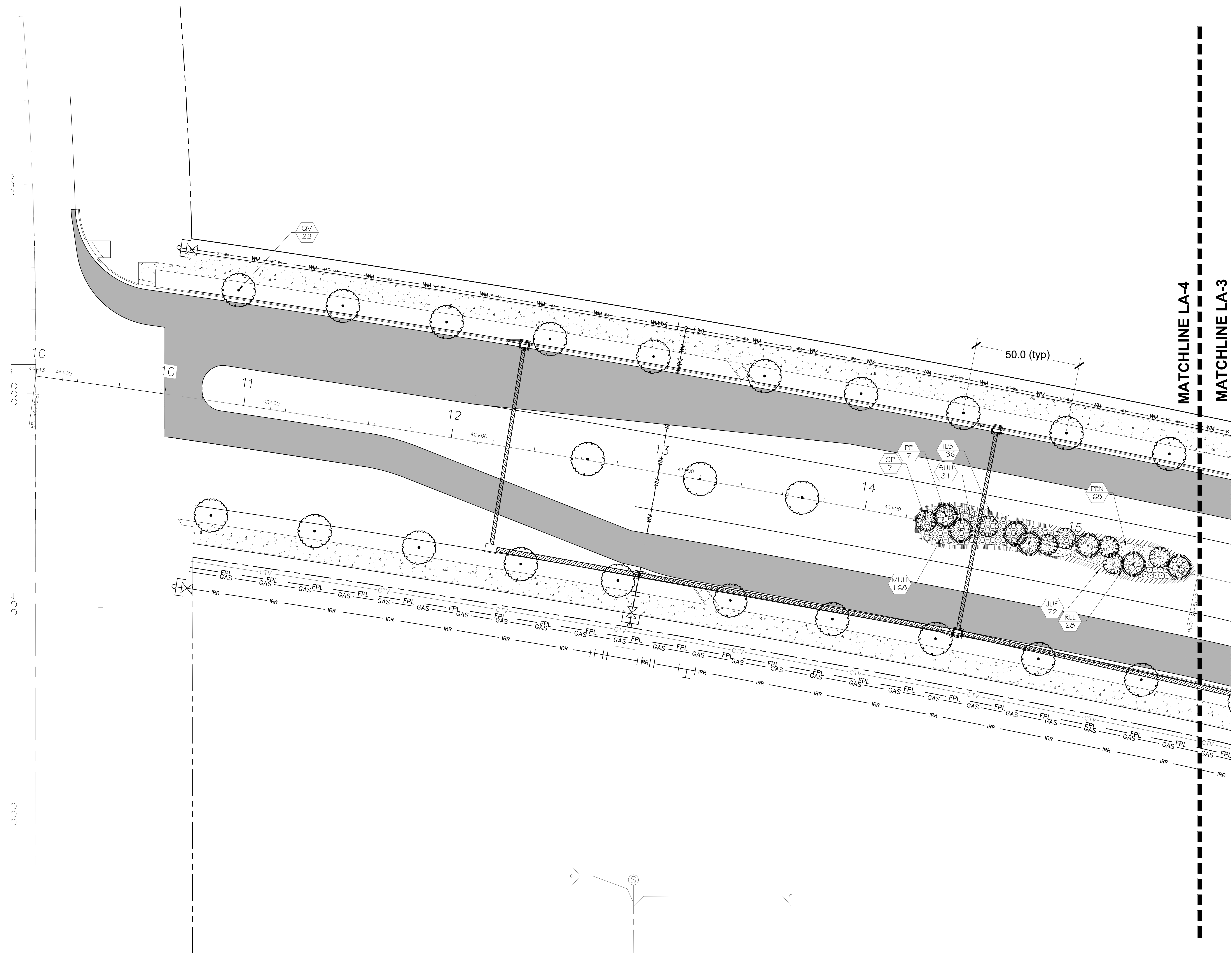

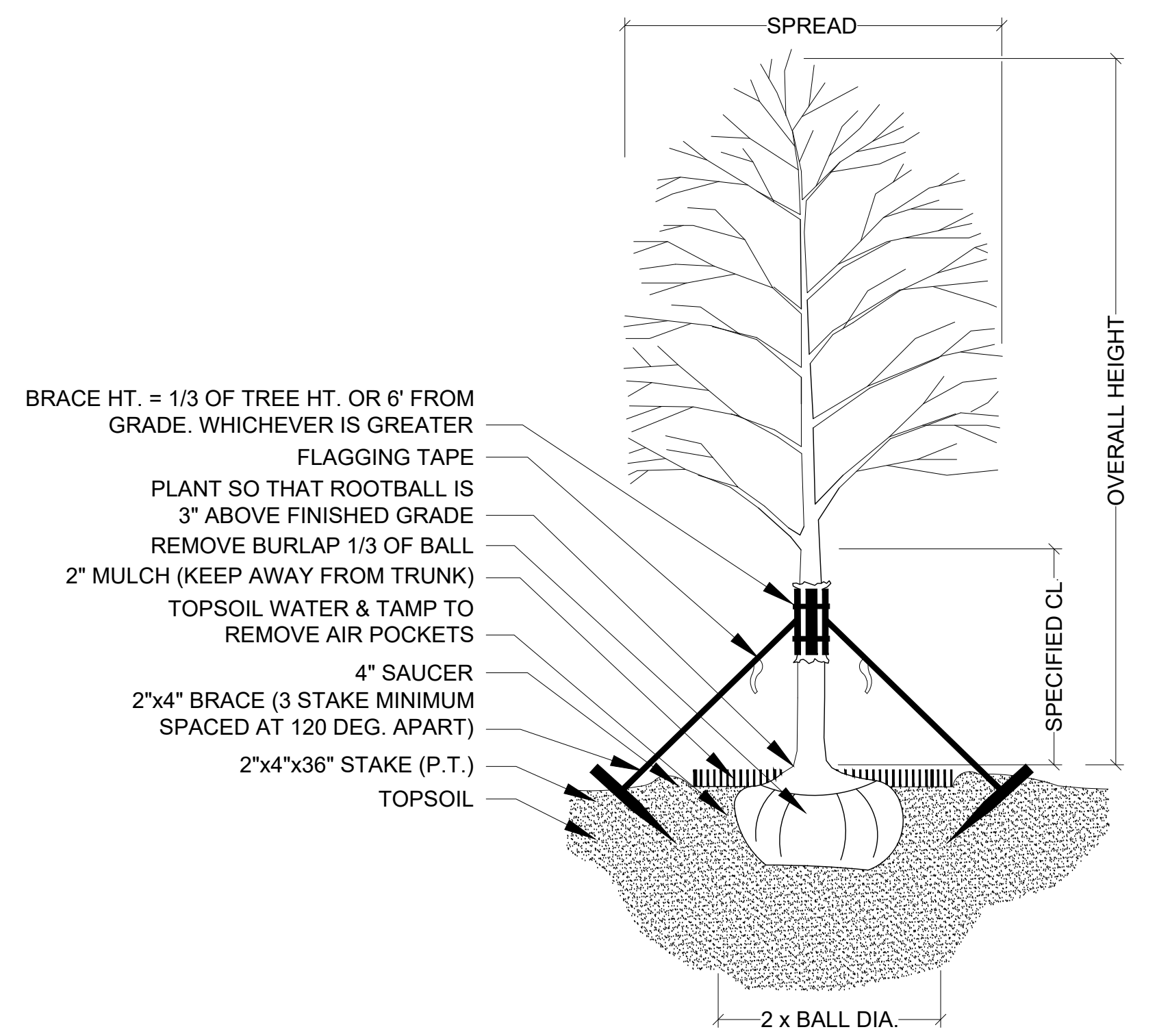

TREE PLANTING & STAKING
NOT TO SCALE

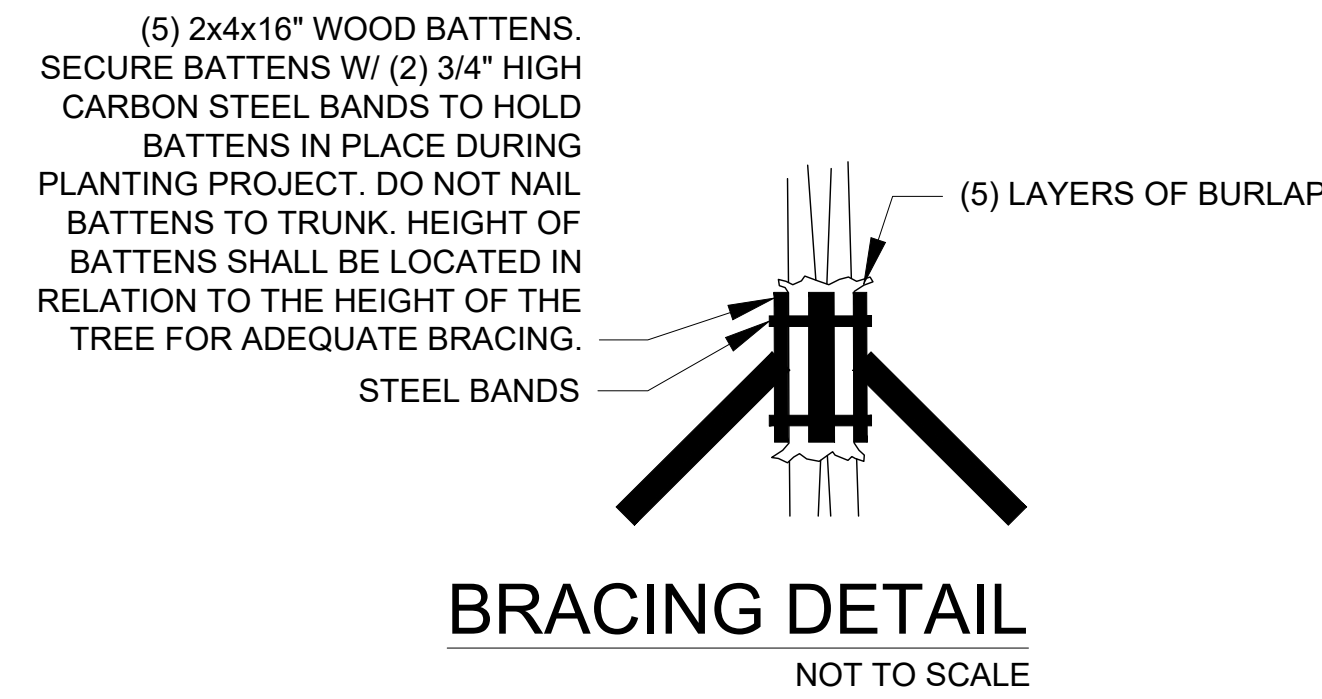

BRACING DETAIL
NOT TO SCALE

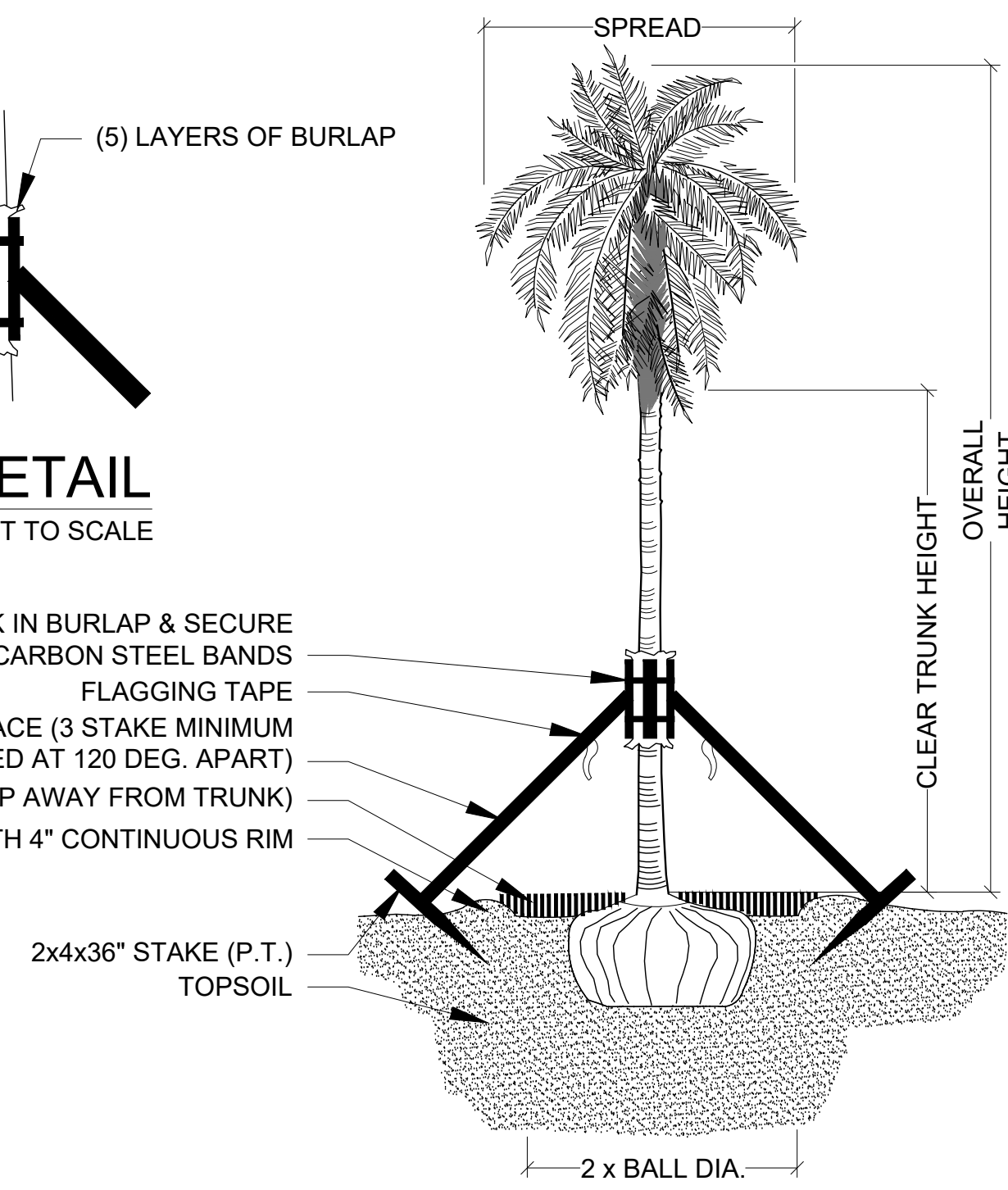

PALM PLANTING - ANGLE STAKE
NOT TO SCALE

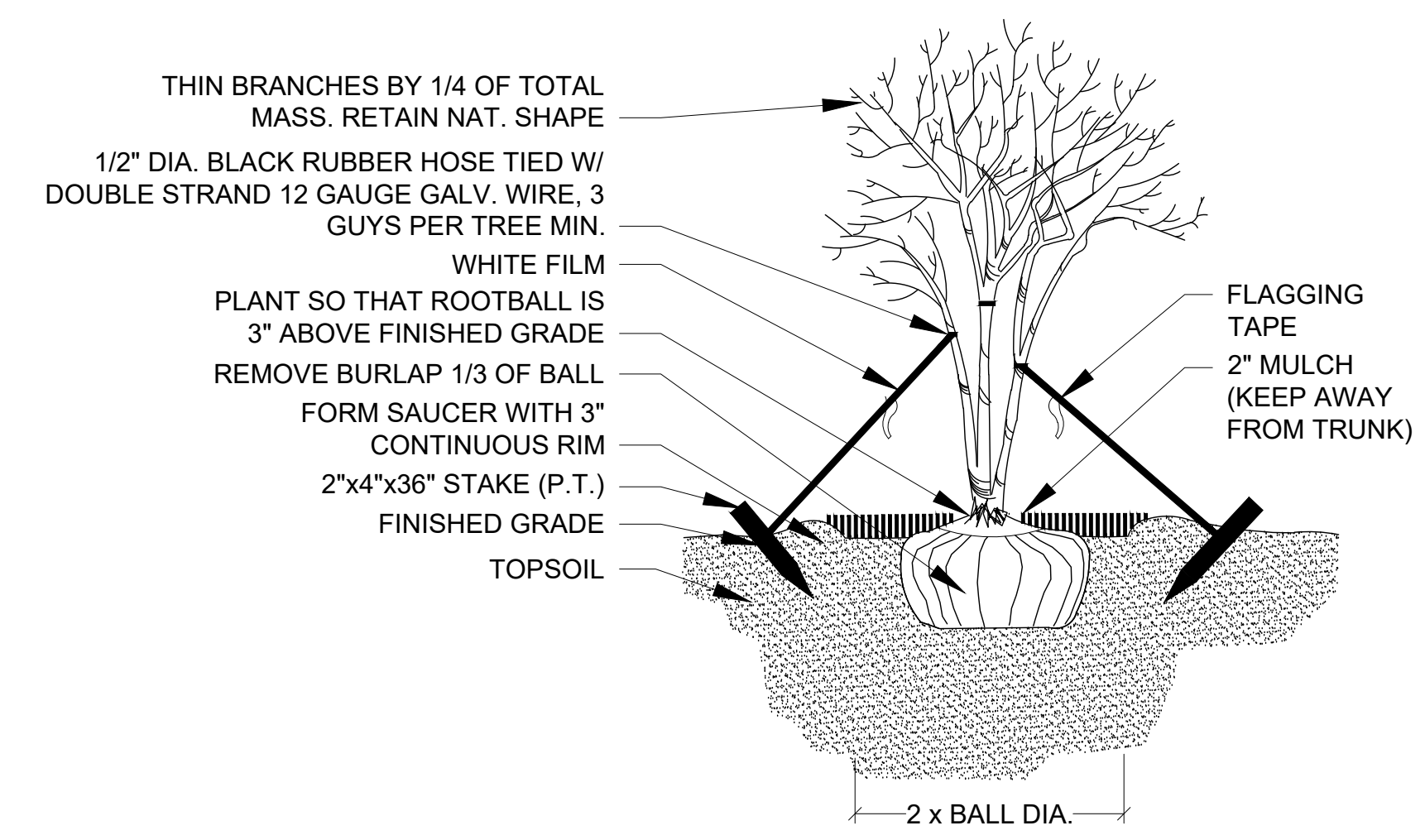

MULTI-TRUNK PLANTING & GUYING
NOT TO SCALE

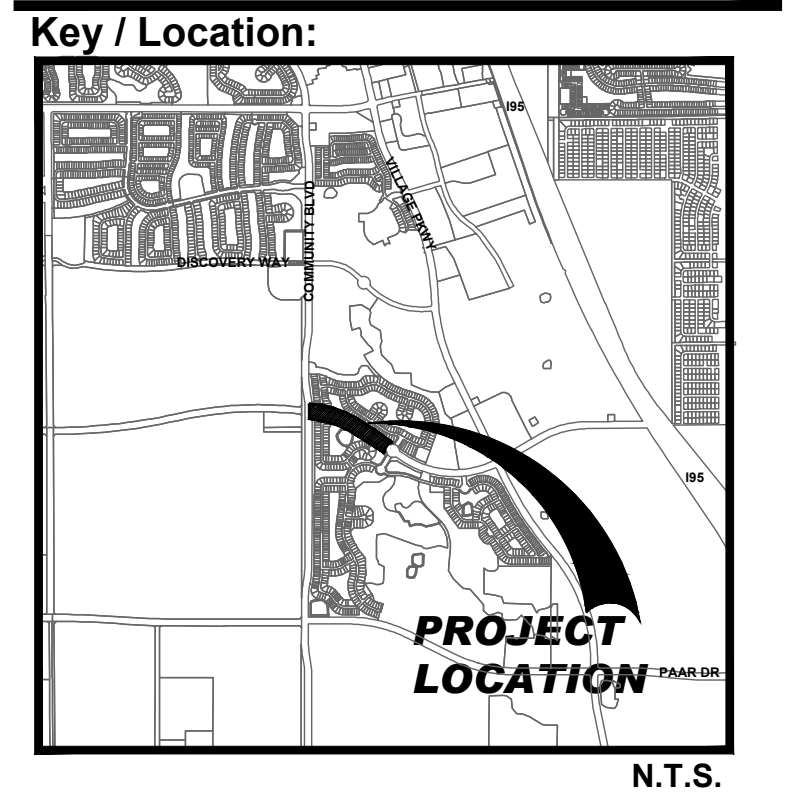

Project Team:



Client & Property Owner: Mattamy Homes, LLC
1500 Gateway Blvd., Suite 220
Boynton Beach, Florida 33426

Land Planner / Landscape Architect: Lucido & Associates
701 East Ocean Boulevard
Stuart, Florida 34994

Engineer: Culpepper and Terpening, Inc.
2980 South 25th Street
Fort Pierce, FL 34981

Surveyor: Caulfield & Wheeler, Inc.
410 S.E. Port St. Lucie Blvd.
Port St. Lucie, Florida 34984

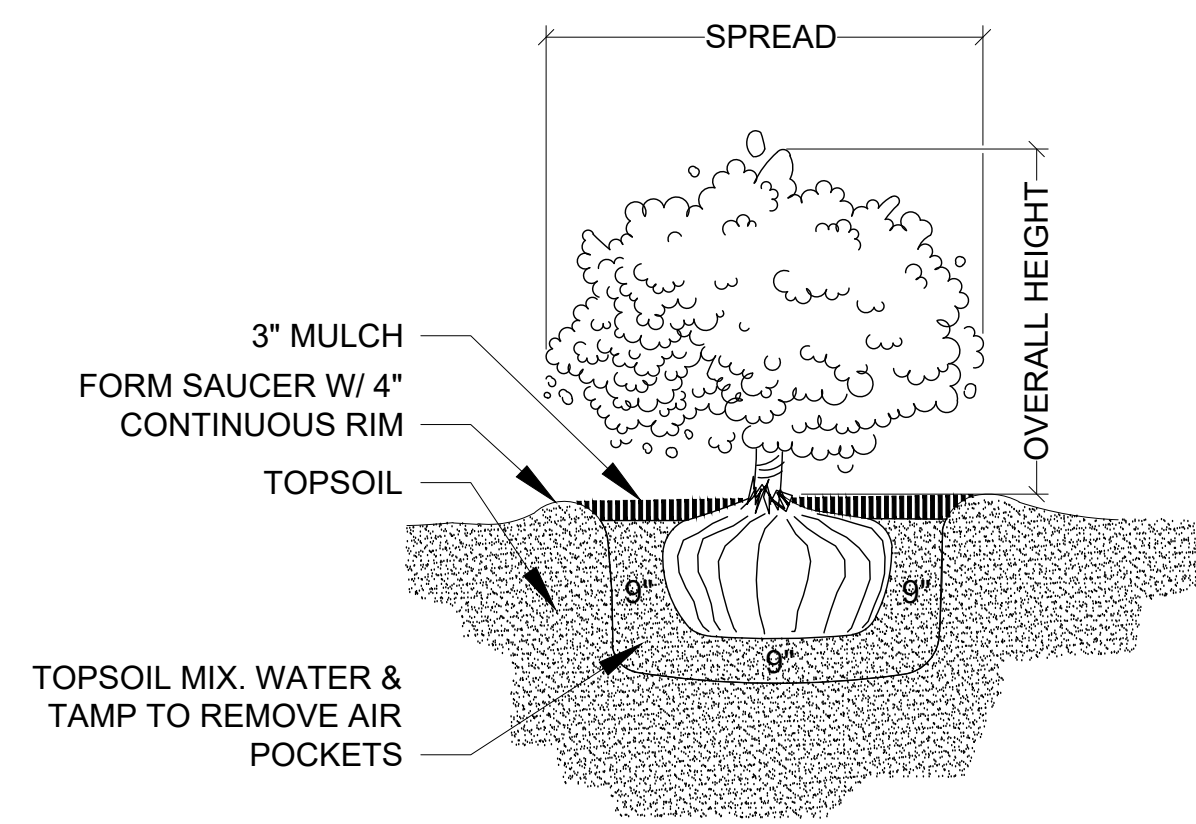

SHRUB PLANTING
NOT TO SCALE

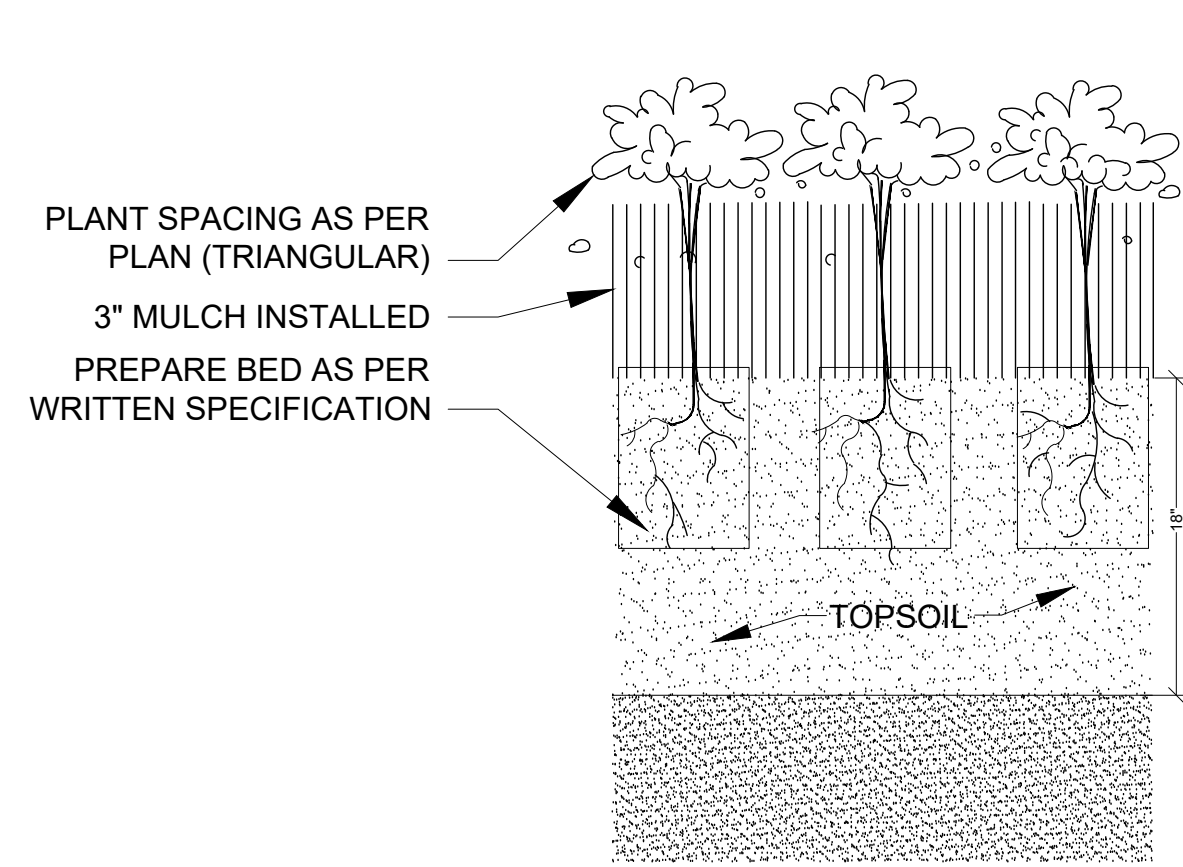

GROUNDCOVER PLANTING DETAIL
NOT TO SCALE

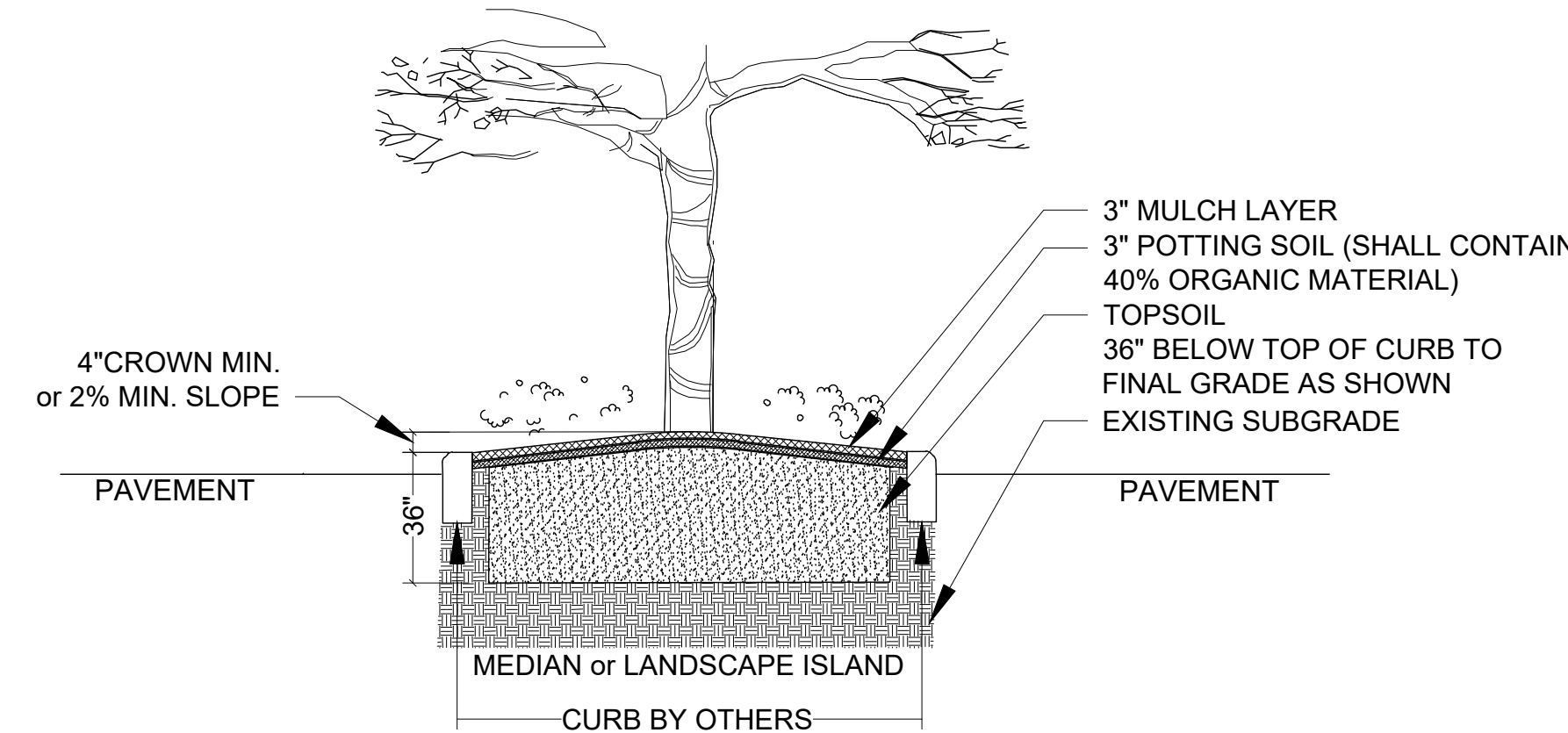

LANDSCAPE AREA PREPARATION DETAIL
NOT TO SCALE

- * TOPSOIL SHALL BE NATURAL, FRIABLE, FINE LOAMY SOIL, POSSESSING CHARACTERISTICS OF REPRESENTATIVE TOPSOIL IN THE VICINITY OF THE PROJECT SITE THAT PRODUCES HEAVY GROWTH.
- * TOPSOIL SHALL HAVE A PH RANGE OF 5.5-7.4, FREE FROM SUBSOIL, WEEDS, LITTER, SODS, CLAY, STONES, STUMPS, ROOTS, TRASH, HERBICIDES, TOXIC SUBSTANCES, OR ANY OTHER MATERIAL WHICH MAY BE HARMFUL TO PLANT GROWTH, OR HINDER PLANTING OPERATIONS.
- * TOPSOIL SHALL CONTAIN A MINIMUM OF 3% ORGANIC MATERIAL.
- * TOPSOIL MUST PERCOLATE WATER AT A RATE OF 1" PER HOUR (SEE ALSO DRAINAGE TESTING DETAIL FOR TREES)
- * LANDSCAPE AREA SOILS SHALL BE APPROVED BY LANDSCAPE ARCHITECT/OWNER PRIOR TO PLANTING

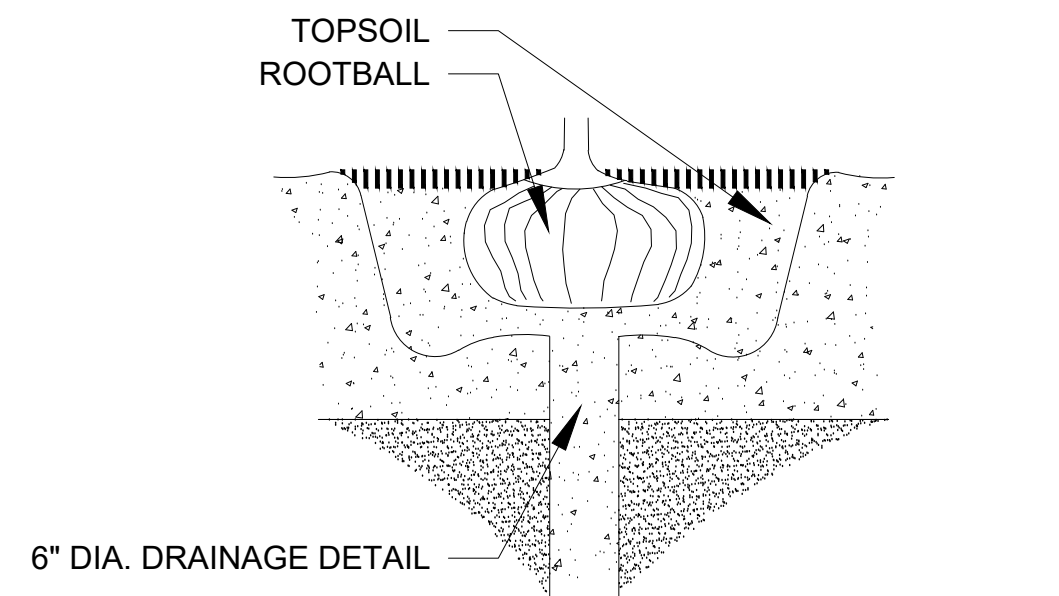

DRAINAGE TESTING DETAIL
NOT TO SCALE

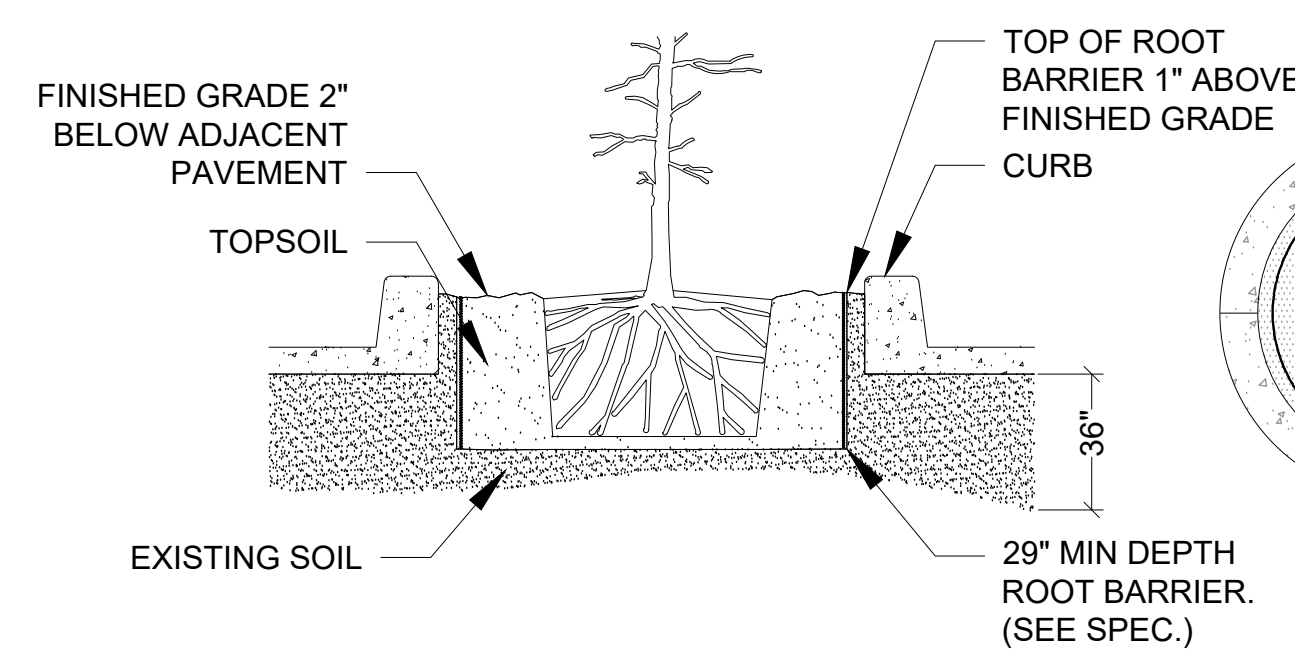

SPECIAL APPLICATIONS ROOT BARRIER DETAIL
NOT TO SCALE

- NOTES:
 1- ROOT BARRIER SHALL BE "BIO-BARRIER 29" DEPTH OR APPROVED EQUAL.
 2- ROOT BARRIER SHALL BE INSTALLED PER MANUFACTURER'S SPECIFICATIONS AND RECOMMENDATIONS.

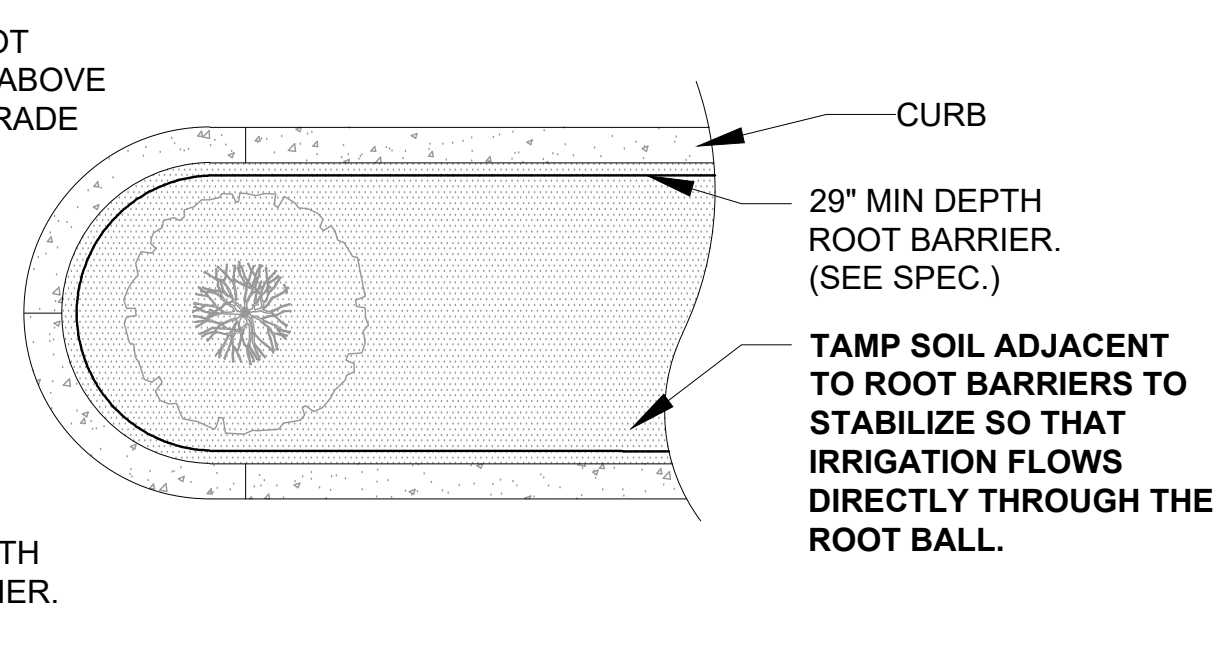

TREE PROTECTION BARRICADE
NOT TO SCALE

- NOTES:
 1- SEE LANDSCAPE PLAN FOR FENCE ALIGNMENT.
 3- NO PRUNING SHALL BE PERFORMED EXCEPT BY APPROVED ARBORIST.
 4- NO EQUIPMENT SHALL OPERATE INSIDE THE PROTECTIVE FENCING INCLUDING DURING FENCE INSTALLATION AND REMOVAL.

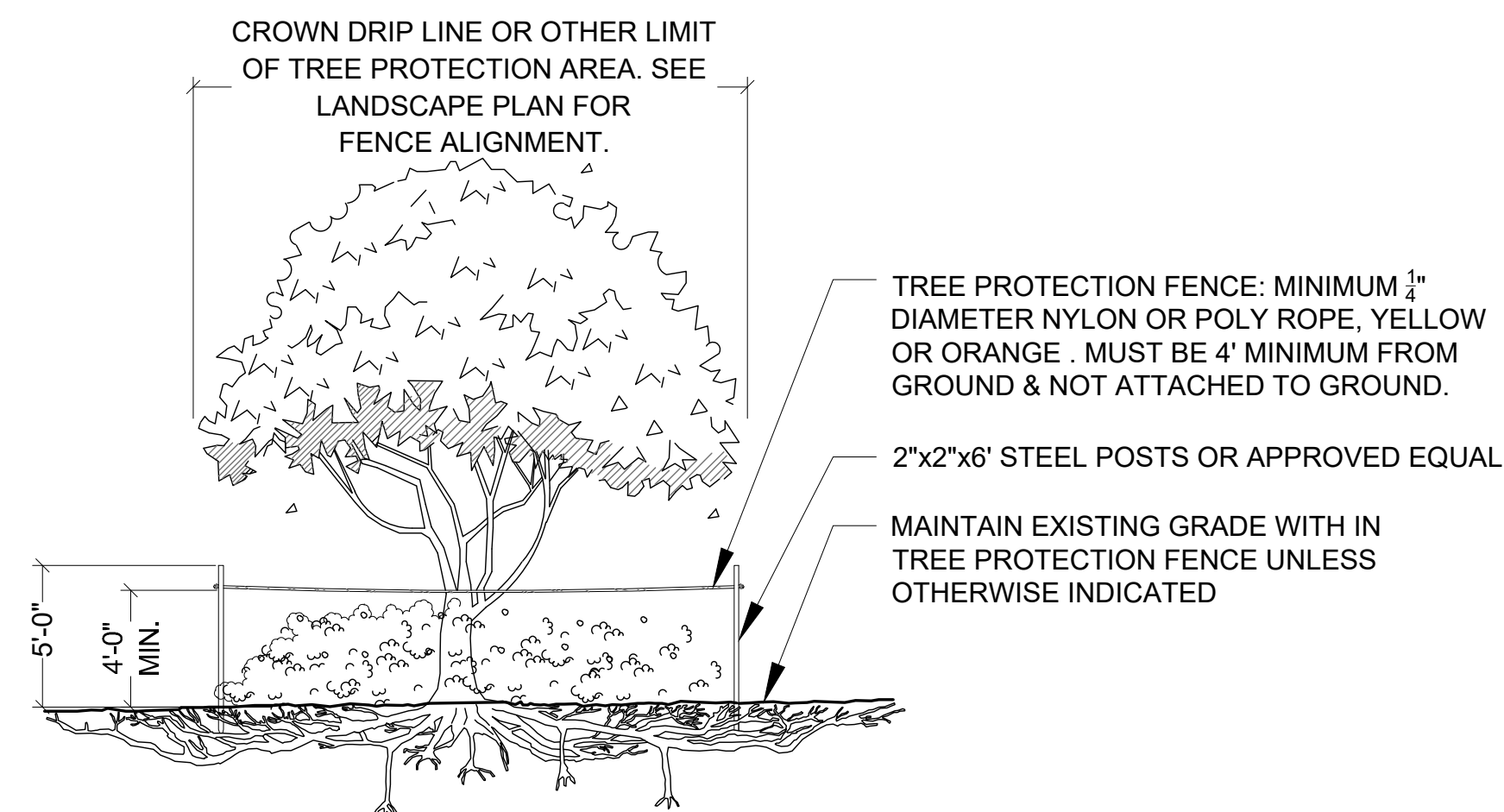

DRAINAGE TESTING/DRAINAGE CHANNEL REQUIREMENTS.

PRIOR TO PLANTING, ALL PLANTING PITS SELECTED FOR TESTING SHALL BE TESTED IN THE FOLLOWING MANNER.

- DIG EACH PLANTING PIT TO THE MINIMUM SPECIFIED SIZE.
- FILL PLANTING PIT WITH TWELVE INCHES (12") OF WATER. IF THE WATER LEVEL DROPS FOUR (4") OR MORE WITHIN FOUR (4) HOURS, THE DRAINAGE IS SUFFICIENT AND A DRAINAGE CHANNEL IS NOT REQUIRED. IF THE WATER LEVEL DROPS LESS THAN FOUR INCHES (4") WITHIN THE FOUR (4) HOUR PERIOD, A DRAINAGE CHANNEL IS REQUIRED.
- WHERE REQUIRED, THE DRAINAGE CHANNEL MUST EXTEND DOWN THROUGH THE NON POROUS SOIL AND INTO POROUS SOIL. (SEE DETAIL)
- ALL MATERIAL REMOVED FROM THE DRAINAGE CHANNEL SHALL BE DISCARDED.
- WHEN BACKFILLING PLANTING PITS WITH NATIVE TOPSOIL, CARE MUST BE TAKEN TO KEEP THE CONSISTENCY OF THE SOIL MIX THE SAME THROUGHOUT THE PLANTING PIT AND DRAINAGE CHANNEL.

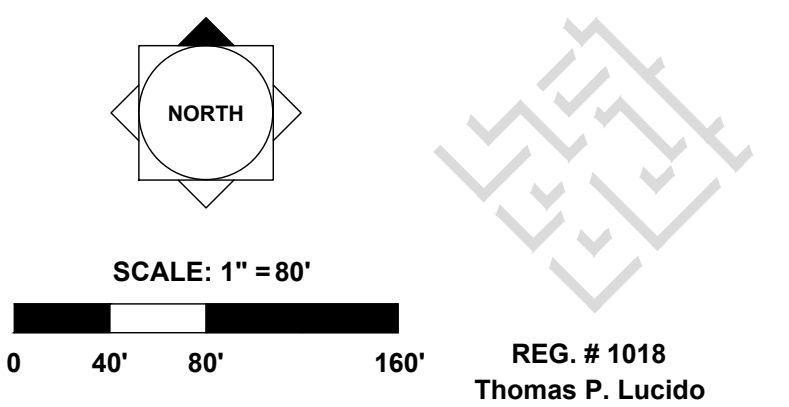

Designer: SAW Sheet
 Manager: SG
 Project Number: 20-276.40
 Municipal Number: P
 Computer File: 20-276.40 Marshall Parkway Landscape.dv

LA-5

LANDSCAPE SPECIFICATIONS

PART 1: GENERAL CONDITIONS

- 1.01 SCOPE: The landscape contract includes the supplying and planting of all trees, shrubs, vines, and ground cover together with all necessary labor, equipment, tools and materials needed for the successful completion, execution and maintenance of the landscape plans.
1.02 AGENCY STANDARDS: Grades and standards of plant materials to be used shall be true to name, size, condition and graded Florida #1 or better as stated in: Grades and Standards of Florida Plant Materials published by the State of Florida Department of Agriculture, Tallahassee, Florida.
1.03 A SITE EXAMINATION: The Landscape Contractor shall personally examine the site and fully acquaint him/herself with all of the existing conditions in order that no mis-understanding may afterwards arise as to the character or extent of the work to be performed, and, additionally, in order to acquaint him/herself with all precautions to be taken in order to avoid injury to property or persons.
1.04 A ERRORS AND OMISSIONS: The plant list is a part of the drawings and is furnished as a convenience. The plant list indicates the name, size and quantities of specific plant materials as called for and is located on the drawings.
1.05 A EXECUTION OF THE WORK: The Landscape Contractor shall have his labor crews controlled and directed by a Foreman well versed in plant materials, planting methods, reading plans, and coordination between job and nursery in order to execute installation correctly and in a timely manner.
1.06 A PROTECTION OF PUBLIC AND PROPERTY: The Landscape Contractor shall protect all materials and work against injury from any cause and shall provide and maintain all necessary safeguards for the protection of the public.
1.07 A CHANGES AND EXTRAS: The Contractor shall not start work on any changes or "extras" in the project until a written agreement setting forth the adjusted prices has been executed by the Owner and the Contractor.
1.08 A GUARANTEE: The Landscape Contractor shall furnish a written guarantee warranting all materials, workmanship and plant materials, except sod, for a period of 18 MONTHS from the time of completion and acceptance by the Landscape Architect and Owner.
1.09 A CARE AND MAINTENANCE: The Landscape Contractor shall be responsible for the care and maintenance of all plant materials and irrigation when applicable until final acceptance by the Owner or Landscape Architect.
1.10 A SAFETY: It shall be the responsibility of the Landscape Contractor to protect all persons from injury and to avoid property damage.
1.11 A CONTRACTOR QUALIFICATION: The Owner may require the apparent contractor (s) to qualify him/herself to be a responsible entity by furnishing any or all of the following documentary data:
1.12 A INSURANCE AND BONDING: The contractor (s) shall submit proof of insurance for this job for the time period that the work is done.
1.13 A PERMITS AND CERTIFICATES: All contractors shall secure and pay for all permits and certificates required for his/her class of work.

PART 2: MATERIALS

- 2.01 A PLANT MATERIALS: A complete list of plants is shown on the drawings, including a schedule of quantities, sizes, and such other requirements deemed necessary. In the event discrepancies occur, the specifications on the drawings shall govern.
B Substitutions: Substitutions of plant materials or changes in size or spacing of materials will be permitted ONLY upon written authorization by the Owner or the Landscape Architect.
C All plant materials shall have a habit of growth that is normal for the species and shall be healthy, vigorous and equal to or exceed the measurements specified in the plant list, which are the minimum acceptable sizes.
D All plant materials shall be nursery grown, unless otherwise noted, Florida #1 or better and shall comply with all required inspections, grading standards and plant regulations as set forth by the Florida Department of Agriculture's Grades and

Standards for Nursery Plants, most current addition and Grades and Standards for Nursery Plants, most current addition.

- E. Plants that do not have the normal balance of height and spread typical for the respective plant shall not be acceptable.
F. The Landscape Contractor shall install each plant to display its best side. Adjustments may be required if plants are not installed properly and/or approved by the Landscape Architect at no additional cost to owner.

2.02 INSPECTION

- A. The Landscape Architect and Owner may inspect trees and shrubs at place of growth or at site before planting, for compliance with requirements for genus, species, variety, size and quality.
2.03 A. PROTECTION OF PLANT MATERIALS: Balled and burlapped plants (B & B) shall be dug with firm natural balls of earth of sufficient diameter and depth to encompass the fibrous and feeding root system necessary for full recovery of the plant.
B. Plants with broken, damaged or insufficient rootballs will be rejected.
C. All plant material shall be protected from possible bark injury or breakage of branches.
D. Plants which cannot be planted immediately on delivery to the site shall be covered with moist soil, mulch or other protection from the drying of wind and sun.

2.04 STORAGE

- A. All plant materials shall be stored on the site in designated areas, specified by the Landscape Architect or Owner's agent.
B. No plant material shall be stored longer than seventy-two (72) hours unless approved by Landscape Architect and/or owner.
C. The Landscape Architect reserves the right to reject any plant materials not in conformance with these specifications.
D. All rejected material shall be immediately removed from the site and replaced with acceptable material at no cost to the Owner.

2.05 PROTECTION DURING PLANTING:

- A. Trees moved by winch or crane shall be thoroughly protected from chain marks, girdling or bark slippage by means of burlap, wood battens or other approved methods.
B. Landscape Area Preparation. The intent of this section is to ensure a healthy growing environment for all planting material in all landscaped areas.

2.06 TOP SOIL:

- A. Planting soil for all plantings shall consist of topsoil and be natural, friable, fertile, fine loamy soil possessing characteristics of representative topsoil in the vicinity of the project site that produces heavy growth.
B. Landscape Area Preparation. The intent of this section is to ensure a healthy growing environment for all planting material in all landscaped areas.

Existing soils must meet all definitions of 'Topsoil' as described above in all planting areas throughout the site. If existing soils do not meet all definitions of Topsoil, please refer to the 'Landscape Area Preparation' detail. Examination may require existing soils to be tested by an accredited testing laboratory.

2.07 FERTILIZER:

- A. Commercial fertilizer shall comply with the state and local fertilizer laws. Nitrogen shall not be less than 40% from organic source.
B. Thoroughly mixed 3 lbs. of commercial fertilizer to each cubic yard of planting soil.
C. Tableted fertilizer shall be Agriform planting tablets 20-10-5 formula, 21 gram or equal. All trees and shrubs shall be fertilized with tableted fertilizer as follows.

Table with 2 columns: Container/Measure and Tablets. 1 gallon container: 1 tablet; 3 gallon container: 2 tablets; 5 gallon container: 3 tablets; 7 gallon container: 5 tablets.

Large tubs, wire baskets, grow bags, and balled and burlapped material shall have 1 tablet for each 1/2 inch of trunk diameter (measured 3 feet from ground) or for each foot of height or spread of larger shrub material.

MULCH: Mulch material shall be clean, dry, free of weeds, seeds and pests, moistened at the time of application to prevent wind displacement. Cypress &/or Red mulch is prohibited.

PART 3 EXECUTION

- 3.01 A. DIGGING: The Landscape Contractor shall exercise care in digging and other work so as not to damage existing work, including overhead wires, underground pipes and cables and the pipes and hydrants of watering systems.
3.02 A. GRADING: Grading for drainage, swales, etc. to within 4 inches of the finished grade to be provided by others.
3.03 A. PLANTING: Planting shall take place during favorable weather conditions.
B. The Contractor shall call for utility locates and ascertain the location of all utilities and easements so proper precautions can be taken not to damage or encroach on them.
C. Tree Planting shall be located where it is shown on the plan.
D. Excavation of holes shall extend to the required subgrades as specified on the planting diagrams located in the landscape plans.
E. A representative number of planting pits (a minimum of one in every 25 feet throughout the entire site) shall be tested for proper drainage.
F. Planting pits shall be excavated to the following dimensions and backfilled with Topsoil- see Landscape Area Preparation Detail;

- G. No planting or laying of sod shall be initiated until the area has been cleaned of existing sod or other plant materials, rough grass, weeds, debris, stones etc.
H. Each plant shall be planted in an individual hole as specified for trees, shrubs, and vines.
I. All plants shall be set to ultimate finished grade.
J. All flagging ribbon shall be removed from trees and shrubs before planting.
K. Excess excavation (fill) from all holes shall be removed from the site, at no additional expense to Owner.
L. All palms shall be backfilled with sand, thoroughly washed in during planting operations and with a shallow saucer depression left at the soil line for future watering's.
3.04 A. PRUNING: Remove dead and broken branches from all plant material.
B. Make all cuts with sharp instruments flush with trunk or adjacent branch.
C. Trees shall not be poled or topped.
D. Remove all trimming from site.
3.05 GUYING: A. All trees over six (6') feet in height shall, immediately after setting to proper grade, be guyed with three sets of two strands, No. 12 gauge malleable galvanized iron, in tripod fashion.
B. Wires shall not come in direct contact with the tree but shall be covered with an approved protection device at all contact points.

- C. Stake & Brace all trees larger than 12' oa. See detail.
D. Turnbuckles for guying trees shall be galvanized or cadmium plated and shall be of adequate size and strength to properly maintain tight guy wires.
3.06 A. WATER: Each plant or tree shall be thoroughly watered in after planting.
B. Prior to installing any irrigation system components, the contractor shall obtain a water sample from the proposed water supply and conduct a particle size and count analysis on the sample.
3.07 A. SOD: The Landscape Contractor shall sod all areas indicated on the drawings.
B. It shall be the responsibility of the Landscape Contractor to fine grade all landscape areas, eliminating all bumps, depressions, sticks, stones, and other debris.

- C. The sod shall be firm, tough texture, having a compacted growth of grass with good root development.
D. Before being cut and lifted, the sod shall have been mowed at least three times with a lawn mower.
E. 6-6-6 fertilizer with all trace elements is to be applied at the rate of 40 lbs. per 1,000 sq. ft.
F. Solid sod shall be laid with closely abutting, staggered joints with a tamped or rolled, even surface.
G. The finished level of all sod areas after settlement shall be one (1") inch below the top of abutting curbs, walks, paving and wood borders to allow for building turf.
H. If in the opinion of the Landscape Architect, top dressing is necessary after rolling, clean yellow sand will be evenly applied over the entire surface and thoroughly washed in.
3.08 A. SEEDING: The Landscape Contractor shall remove all vegetation and rocks larger than (1") in diameter from areas to be seeded.
B. Application: Argentine Bahia Grass seed- 200 Pounds per acre mixed with common hulled Bermuda seed- 30 lbs. per acre.
C. Roll immediately after seeding with a minimum 500 pound roller, then apply straw mulch at the rate of 2,500 pounds per acre.
D. Apply fertilizer at the rate of 150 lbs. per acre 45-60 days after seeding.

- 3.09 A. CLEANING UP: The contractor shall at all times keep the premises free from accumulations of waste materials or rubbish caused by his employees or work.
3.10 A. MAINTENANCE: Maintenance shall begin immediately after each plant is installed and shall continue until all planting has been accepted by the Owner or Landscape Architect.
B. Proper protection to lawn areas shall be provided and any damage resulting from planting operations shall be repaired promptly.
C. Replacement of plants during the maintenance period shall be the responsibility of the Contractor.
D. In the event that weeds or other undesirable vegetation become prevalent, it shall be the Contractor's responsibility to remove them.
E. Trees or other plant material which fall or are blown over during the maintenance period will be reset by the Contractor at no additional expense to the Owner.
3.11 A. COMPLETION, INSPECTION AND ACCEPTANCE: Completion of the work shall mean the full and exact compliance and conformity with the provisions expressed or implied in the Drawings and in the Specifications, including the complete removal of all trash, debris, soil or other waste created by the Landscape Contractor.
B. Inspection of work to determine completion of contract, exclusive of the possible replacement of plants, will be made by the Owner and/or Landscape Architect at the conclusion of all planting and at the request of the Landscape Contractor.

- C. All plant material shall be alive and in good growing condition for each specified kind of plant at the time of acceptance.
D. After inspection, the Landscape Contractor will be notified by the Owner of the acceptance of all plant material and workmanship.
E. All trees & shrubs shall be straight and in correct position per the landscape plans, details and specifications.

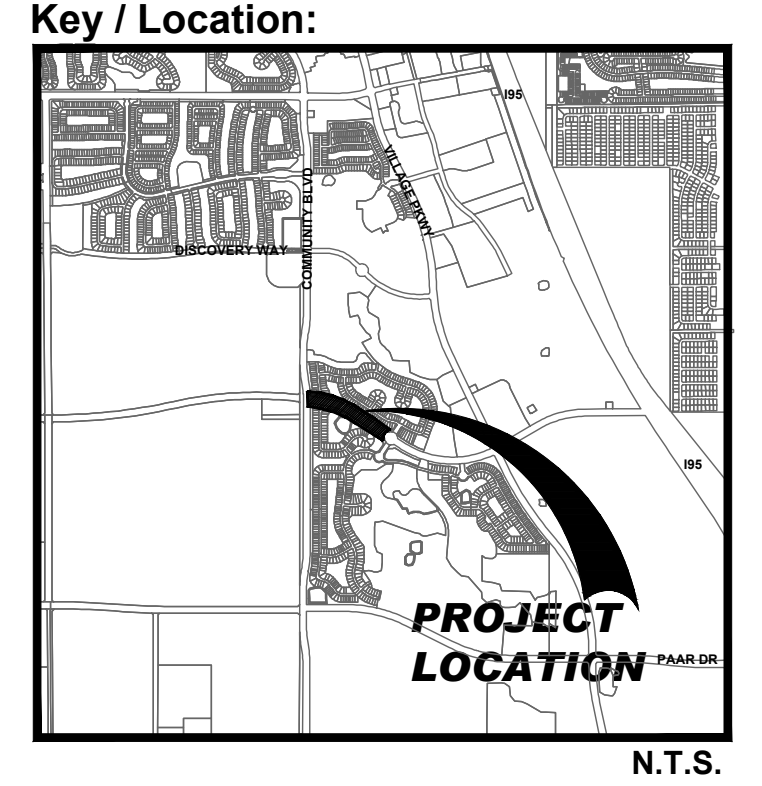
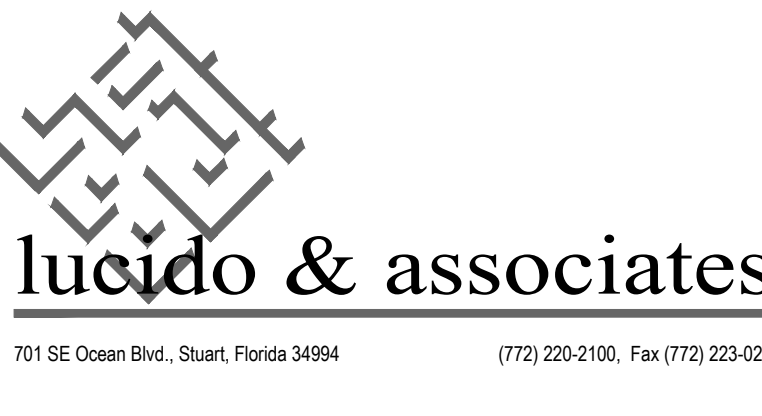

Project Team table listing Client & Property Owner (Mattamy Homes, LLC), Land Planner / Landscape Architect (Lucido & Associates), Engineer (Culpepper and Terpening, Inc.), and Surveyor (Cauffield & Wheeler, Inc.).

Mattamy Homes Marshall Parkway Landscape Additions PSLUSD # Port St. Lucie, Florida Median and Street Tree Landscaping Specifications

Table with 3 columns: Date, By, Description. Row 1: 03.29.23, SAW, Review

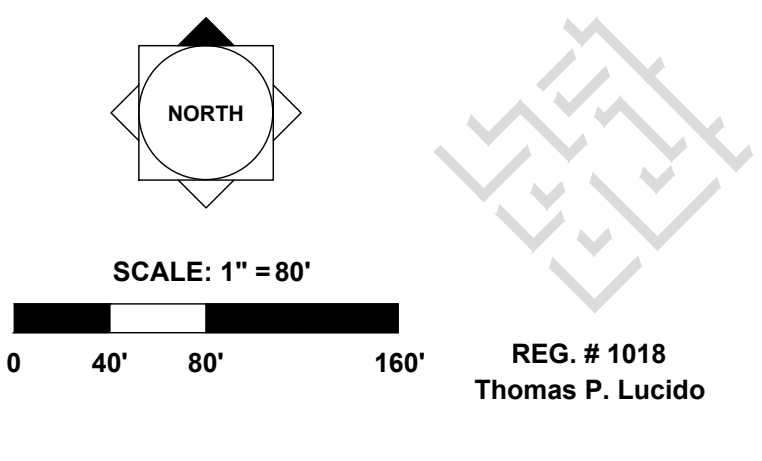

Table with 3 columns: Field, Value, Unit. Designer: SAW, Sheet; Manager: SG; Project Number: 20-276.40; Municipal Number: P; Computer File: 20-276.40 Marshall Parkway Landscape.dv

© Copyright Lucido & Associates. These documents and their contents are the property of Lucido & Associates. Any reproductions, revisions, modifications or use of these documents without the express written consent of Lucido & Associates is prohibited by law.