

2022



# BECKER ROAD OVERLAY DISTRICT DESIGN STANDARDS

## **AMENDMENT NO. 2**

### **THE CITY OF PORT ST. LUCIE**

February 1, 2022

# ACKNOWLEDGEMENTS

## PLANNING AND ZONING DEPARTMENT

Teresa Lamar-Sarno, Deputy City Manager, AICP  
Patti Tobin, Long-Range Planning Administrator, AICP  
Holly Price, Senior Planner, AICP  
~~John Finizio, Principal Planner~~

## TINDALE OLIVER DESIGN

Alex Law, Urban Designer, AICP

## CITY OF PORT ST. LUCIE

121 SW Port St. Lucie Boulevard  
Port St. Lucie, FL 34984-5099  
Phone: (772) 871-5212 (Planning)

ADOPTED by Ordinance 18-26, May 28, 2018 (P17-178)  
AMENDMENT #1 by Ordinance 19-36, July 8, 2019 (P18-143)  
AMENDMENT #2 by Ordinance 22-XX, date, 2022 (P21-202)

# TABLE OF CONTENTS

PREAMBLE.....	i
<i>Background</i> .....	i
<i>Comprehensive Plan Amendments</i> .....	ii
<i>Land Use Conversion Manual</i> .....	ii
<i>Objectives</i> .....	ii
<b>1.0 ADMINISTRATION</b> .....	<b>1</b>
1.1 <i>Intent and Purposes</i> .....	1
1.2 <i>Applicability</i> .....	1
1.3 <i>Approval Process</i> .....	3
1.4 <i>Nonconformities</i> .....	6
1.5 <i>Variances</i> .....	6
1.6 <i>Design Relief to Design Standards</i> .....	6
1.7 <i>Definitions</i> .....	10
<b>2.0 REGULATING PLAN</b> .....	<b>14</b>
2.1 <i>Purpose</i> .....	14
2.2 <i>Becker Road Subdistricts</i> .....	14
2.3 <i>Prohibited and Allowed Uses</i> .....	15
<b>3.0 SUBDISTRICTS &amp; BUILDING TYPES</b> .....	<b>15</b>
3.1 <i>Purpose</i> .....	15
3.2 <i>Applicability</i> .....	15
3.3 <i>Building Type Overview</i> .....	15
3.4 <i>General Requirements</i> .....	15
3.5 <i>Encroachments</i> .....	21
3.6 <i>Building Types by Subdistrict</i> .....	23
3.7 <i>Residential Subdistrict - Townhouse Building Types</i> .....	27
3.8 <i>Residential Subdistrict - Multifamily Building Types</i> .....	30
3.9 <i>Professional Subdistrict – Commercial/Office/Mixed-Use Building Types</i> .....	33
3.10 <i>Village Subdistricts – Commercial/Office/Mixed-Use Building Types</i> .....	35
3.11 <i>Activity Center Subdistricts – Commercial/Office/Mixed-Use Building Types</i> .....	39

# TABLE OF CONTENTS

<b>4.0</b>	<b>ARCHITECTURAL DESIGN STANDARDS</b>	<b>42</b>
4.1	<i>Purpose</i>	42
4.2	<i>Subdistrict Architectural Styles</i>	42
4.3	<i>Prohibited Façade Features and Materials</i>	42
4.4	<i>General Building Articulation</i>	42
4.5	<i>Building Color</i>	44
4.6	<i>Florida Vernacular Style</i>	44
<b>5.0</b>	<b>LANDSCAPING</b>	<b>49</b>
5.1	<i>Purpose</i>	49
5.2	<i>Applicability</i>	49
5.3	<i>General</i>	48
5.4	<i>Frontage Landscape Buffers</i>	48
5.5	<i>Frontage Sidewalks</i>	51
5.6	<i>Frontage Landscape Buffers - Landscaping</i>	53
5.7	<i>Building Perimeter Landscape Strips</i>	54
5.8	<i>Site Perimeter Landscape Buffers</i>	55
5.9	<i>Parking Lot Landscape Buffers</i>	55
5.10	<i>Detention / Retention Area Landscaping</i>	57
<b>6.0</b>	<b>COMMON OPEN SPACE</b>	<b>58</b>
6.1	<i>Corner Open Space at Major Intersections</i>	58
6.2	<i>Becker Road and Port St. Lucie Boulevard Corner Intersections</i>	58
6.3	<i>Other Becker Road Corner Intersections</i>	58
6.4	<i>Encroachments into Frontage Landscape Buffers</i>	59
<b>7.0</b>	<b>PARKING &amp; ACCESSIBILITY</b>	<b>60</b>
7.1	<i>Purpose</i>	60
7.2	<i>Applicability</i>	60
7.3	<i>Parking Location</i>	60
7.4	<i>Amount of Off-Street Parking</i>	62
7.5	<i>Blocks: Vehicular and Pedestrian Access</i>	62
7.6	<i>Bicycle Parking</i>	65

# PREAMBLE

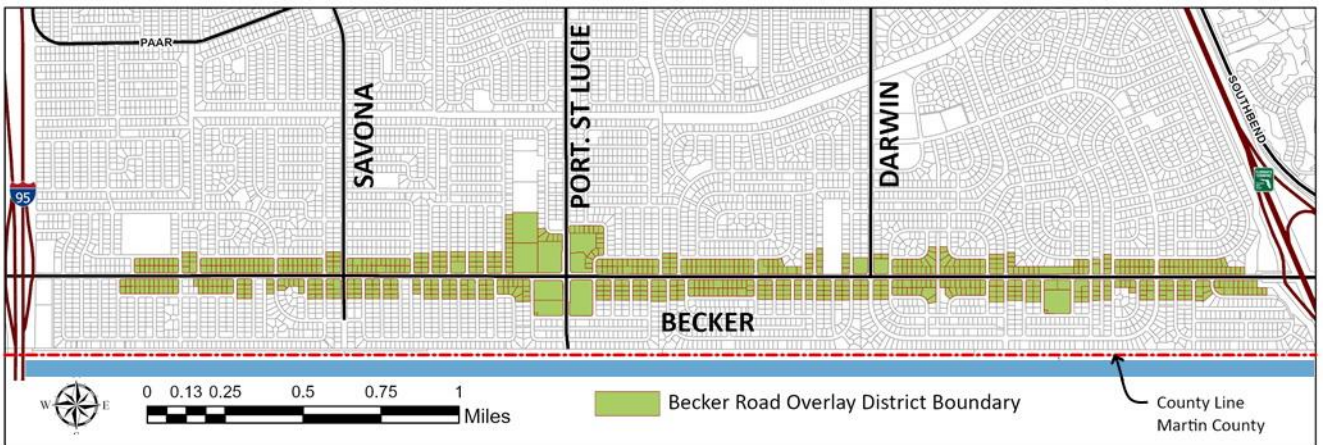
## *Background*

In 2017, the City of Port St. Lucie created Neighborhood Action Plans for many of the original areas developed in the city. A Neighborhood Action Plan for Planning Area 4 South (PA-4S), which includes the Becker Road corridor, was created to guide City policy and decision-making over the next 10-15 years in order to establish a vision for the future and to advance the City's strategic goals of having stable neighborhoods, quality housing, a diverse local economy, more mobility choices, and enhanced leisure opportunities for active lifestyles. In addition, the creation of an overlay district was recommended as a means to guide the appearance of future development of properties located along Becker Road. An overlay district is a specific geographic area in which additional zoning and design requirements are applied as a means to accomplish a desired land development pattern.

The Becker Road Overlay District (BROD) extends along Becker Road approximately 3.75 miles from Interstate 95 on the west to the Florida Turnpike on the east (**Map 1**). The framework for the BROD was identified through public input to accomplish the following:

- Create a sense of place and community,
- Address the current land use and zoning issues which are impeding redevelopment,
- Promote the development of mixed-use and commercial uses,
- Establish site and building design standards,
- Reduce driveway access conflicts along Becker Road, and
- Increase the number of parks, open spaces, and recreational facilities.

*Map 1. Vicinity Map of Becker Road Overlay District (BROD) Boundary*



The City of Port St. Lucie was awarded a Community Planning Technical Assistance Grant from the Florida Department of Economic Opportunity (DEO) to prepare form-based design standards for the Becker Road Overlay District (BROD) to address design issues such as the building articulation and the location of the building(s) on a site in relation to adjacent streets, setbacks, parking, and landscaping.

### *Comprehensive Plan Amendments*

In late 2017, the City of Port St. Lucie initiated a Comprehensive Plan amendment to implement the recommendations of the neighborhood plan for Planning Area 4 South (PA-4S) located along Becker Road with the following objectives: Promote business and economic development opportunities, remove existing single-family residential zoning areas that abut Becker Road, and protect single-family residential areas located to the north and south of Becker Road. The Comprehensive Plan amendment was approved by the City on November 13, 2018. The amendment changed the future land use of 783 lots from RL (Low Density Residential) to CL (Limited Commercial), ROI (Residential, Office, & Institutional), RM (Medium Density Residential), MU (Mixed-Use), or OSR (Open Space Recreational). In addition, the amendment created a new Office (O) future land use designation that is only compatible with the Professional (P) zoning district.

### *Land Use Conversion Manual*

In the 1980s, the City of Port St. Lucie adopted a process for converting single-family platted lots located along major roadways into larger parcels for commercial, office, institutional, and multifamily uses. The City's Land Use Conversion Manual was adopted in 1984 to modernize antiquated subdivisions and to protect stable single-family neighborhoods. The City's Land Use Conversion Manual has been revised and approved to foster the type of commercial, office, and multifamily development set forth by the Becker Road Overlay District (BROD) Design Standards.

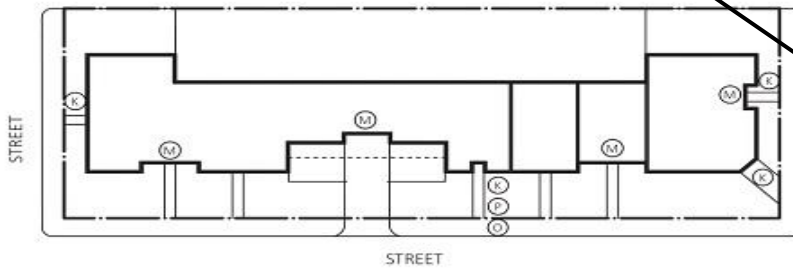
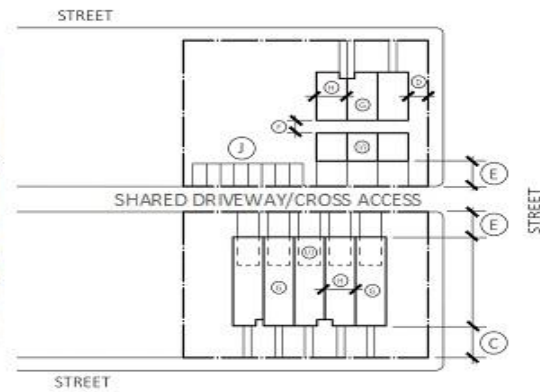
### *What is Form-Based Code? Objectives*

~~Form-based codes are an alternative approach to zoning that promotes pedestrian-oriented, mixed-use environments that are intended to foster a sense of a place. These codes, consisting of maps, diagrams, and narrative, are legal design regulations that delineate with more specificity than typical zoning codes the desired physical form, placement, size, architectural style, and other development features. These codes are only applicable to properties located within the BROD.~~



A principal objective of the form-based code in this overlay is to create an attractive, pedestrian-friendly environment by implementing the following practices:

- Place buildings along Becker Road or Port St. Lucie Boulevard with parking in the rear,
- Require open spaces in the form of greens, plazas, and courtyards with features such as benches, fountains, public art, gazebos or other garden furniture,
- Promote the development of buildings that have windows and building articulation as a means to foster more attractive architecture, and
- Create an inter-connected system of sidewalks to promote walkability and driveways to make access to nearby developments more convenient.



# 1.0 ADMINISTRATION

## 1.1 Intent and Purposes

The intent of this document is to provide standards to implement the Becker Road Overlay District (BROD) Design Standards for the following purposes:

- Establish land development regulations applicable to underlying zoning districts within the BROD,
- Establish design standards for site and building development in the BROD that are pedestrian-friendly,
- Provide multifamily residential development options that are compatible in scale, design, and intensity with Becker Road and the surrounding neighborhoods,
- Foster economic activity that is compatible in use, scale, design, and intensity with Becker Road and the surrounding neighborhoods.

## 1.2 Applicability

The BROD Design Standards apply to the following land use and zoning districts as depicted in Compatible Land Use and Zoning Districts, **Table 1-1** and as illustrated on the Regulating Plan, **Map 2-1, page 10**.

**Table 1-1. Compatible Land Use and Zoning Districts**

Land Use	Zoning <sup>1, 2</sup>
General Commercial (CG)	CG, CN, P, LMD, PUD <sup>3</sup>
Limited Commercial (CL)	CN, P, LMD, PUD
Residential Office Institutional (ROI)	LMD, P, Residential PUD <sup>3</sup> between 5-8 DUPA, I
Mixed-Use (MU)	PUD <sup>3</sup>
Office (O)	P, PUD <sup>3</sup>
Medium Density Residential (RM)	Residential PUD <sup>3</sup> between 5-8 DUPA, I
Open Space Recreational (OSR)	OSR ( See Section 1.2.7)

<sup>1</sup> **Zoning Acronym Definitions:** General Commercial (CG), Neighborhood Convenience Commercial (CN), Limited Mixed-Use (LMD), Professional (P), Multifamily Residential (RM-5, RM-8), Planned Unit Development (PUD), Institutional (I), Open Space Recreational (OSR), Dwelling Units Per Acre (DUPA).

<sup>2</sup> Maximum number of dwelling units is 8 DUPA for all properties with an RM and ROI future land use.

<sup>3</sup> PUD zoning requires a minimum of 1.8 acres in the BROD.

1. **Rezoned Properties** - The BROD Design Standards shall apply to proposed new buildings and undeveloped properties located within the conversions areas that have obtained approval for the appropriate zoning. The BROD Design Standards will be implemented at the time a Special Exception Use (SEU) or Site Plan application is submitted for approval by the City.



2. **Existing Single-Family Homes** - The conversion of a single-family home to a commercial or non-single-family use is permitted provided the BROD Design Standards and other applicable development regulations are met. The conversion may require significant renovation. The removal of houses from conversion areas is preferred.
3. **Single-Family Residential Zoning** - Properties zoned single-family residential (RS-2) are exempt from the BROD Design Standards.
4. **Rehabilitated or Remodeled Structures** – **Refer to Citywide Design Standards**. Design standards shall apply to all properties undergoing redevelopment when the sum of all building costs is equal to or exceeds 50% of the appraised value of the building. (See also City Zoning Code Section 158.282).
5. **Removal or Destruction of Non-conforming Structures** – **Refer to Citywide Design Standards**. When any non-conforming building or structure is removed or otherwise destroyed to an extent equal to or exceeding 50% of the replacement cost, both the property and any building or structure erected or maintained thereon shall conform in all respects to the regulations and requirements of the BROD Design Standards. (See also City Zoning Code Section 158.282).
6. **Conflict with Other City Codes** - Where conflict occurs with the BROD Design Standards and other City land development regulations, the standards described in this document shall supersede.
7. **Open Space Recreation (OSR) Land Use or Zoning Limitations** - Chapter 3.0 (Subdistricts & Building Types) does not apply to properties with Open Space Recreation (OSR) future land use or zoning.

## 1.3 Approval Process

Development review for site plan approval shall follow adopted procedures for design review and site plan approval for all applicable development within the City of Port St. Lucie as established in Sections 158.235 to 158.246 of the City Zoning Code. After receipt of a complete application, City staff will review the drawings and documents and provide written comments to the applicant prior to the Site Plan Review Committee (SPRC) meeting.

The Planning and Zoning Department encourages applicants to request a pre-application meeting to discuss their initial design concepts prior to submitting a site plan, floor plans, elevations, and construction plans to the City Planning and Zoning Department for SPRC review.

### **1.3.1. Submittal Requirements**

All site plan submittals shall be made utilizing the City's online application portal. Provide one (1) digital set online to the online portal and one (1) hard copy set to the Planning and Zoning Department.

Include the Planning and Zoning Department project number at the lower right corner of drawings and other documents. Example: (P21-123). Planning staff will send this file number to the applicant after the project has been reviewed.

1. **Site Plan or Concept Plan:** See City Zoning Code Section 158.238 for the list of Site Plan submittal requirements. A Site Plan Checklist may be downloaded from the Planning and Zoning Department website.
2. **Architectural Elevations / Floor Plan:** The building elevations shall list the selected design elements from Section 4.6.3 (Architectural Elements) of the Becker Road Overlay District (BROD) Design Standards. Elevations shall show building and roof form, windows, doors, materials, colors, and any other architectural features. Include window and door transparency calculations on the building elevations page. Indicate Sherwin Williams paint color name and number on the building elevations page.  
  
Provide color elevations of all building façades. Development that is 2.5 acres or more in size shall provide a color rendering.
3. **Landscape Plan / Irrigation Plan:** Preliminary Landscape Plan must be submitted with the Site Plan to the Site Plan Review Committee (SPRC).
4. **Construction Drawings:** Construction Plans may also be submitted with the Site Plan to the Site Plan Review Committee (SPRC) or they may be submitted to the SPRC after the Site Plan has been approved by the SPRC.

~~Major and Minor Plans:~~ After comments from the SPRC have been addressed by the applicant, the Planning and Zoning Department will make a recommendation to the Planning and Zoning Board and the City Council for major site plans or to the City Council for minor site plans as required by City ordinance.

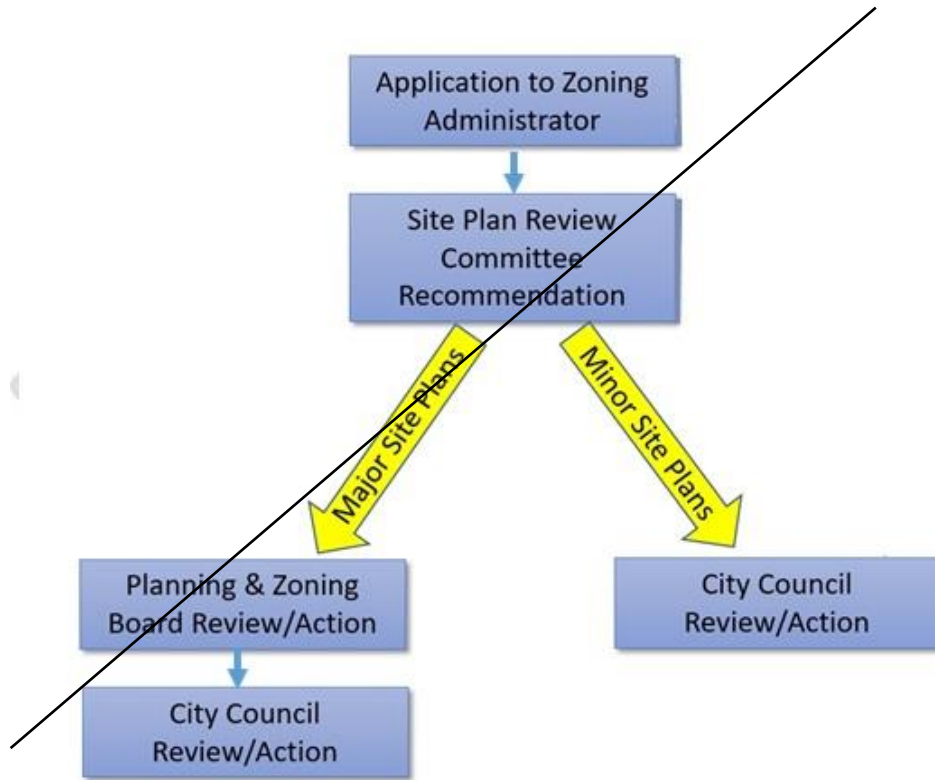
~~Major site plans include any development involving 50 dwelling units or more, or 10,000 square feet or more of non-residential gross floor area. Minor site plans include any development involving fewer than 50 dwelling units or less than 10,000 square feet of non-residential gross floor area.~~

~~Site Plan Amendments:~~ Subject to meeting the required criteria, the Zoning Administrator may refer

requests for minor site plan revisions as defined in Section 158.237(C) to the SPRC for approval or for a recommendation to the or the City Council for final approval.

The site plan review process is graphically summarized below (**Figure 1-1**).

**Figure 1-1: Approval Process**



### 1.3.1 Submittal Requirements

Unless indicated otherwise in the BROD Design Standards, refer to City Code Section 158.238 for the Site Plan Submittal requirements.

1. A digital copy of the required drawings and documents shall be uploaded online for distribution to other Site Plan Review Committee departments at the City of Port St. Lucie Planning & Zoning Department website (<https://www.cityofpsl.com>) > Applications & Instructions > Online Submittals —Or— <https://submit.cityofpsl.com/>.

2. In addition, submit (1) hard-copy set of required drawings and documents to the Planning and Zoning Department.

1. **Site Plan or Concept Plan.**

2. **Architectural Elevations / Floor Plan:** The building elevations page shall list the selected design elements from Section 4.6.3 (Architectural Elements). Elevations shall show building and roof form, windows, doors, materials, colors, and any other architectural features. Include window and door transparency calculations on the building elevations page.

~~Indicate Sherwin-Williams paint color name and number on the building elevations page where applicable.~~

~~Provide color elevations of all building facades that face a street on an 8.5 x 11 or an 11 x 17 sheet of paper. Development that is 2.5 acres or more in size shall provide a color rendering.~~

- ~~3. **Landscape Plan / Irrigation Plan / Construction Drawings:** Landscape and Irrigation Plans may also be submitted with the Site Plan to the Site Plan Review Committee (SPRC) or they may be submitted to the SPRC with the Detail Construction Plans after the Site Plan has been recommended for approval by the SPRC.~~

### *1.3.2 Final Site Inspection Request*

~~Requests to the Planning and Zoning Department for final inspection shall be accompanied by an Site Plan Inspection Request Form and the architect's (or structural engineer's, if applicable) and the landscape architect's original signed and sealed letter of compliance indicating that the building and the landscaping have been built or installed as depicted on the Site Plan, Elevations, and Landscape Plan.~~

~~**Certificate of Occupancy:** Pursuant to Chapter 162, any requirement for Public Art shall be met, if applicable.~~

## 1.4 Nonconformities

Nonconforming lots, uses, and site conditions shall be subject to the provisions of Article XIV, Nonconforming Uses, of the City Zoning Code.

## 1.5 Variances

Proposed variances to the provisions of the Becker Road Overlay District (BROD) Design Standards shall be subject to the rules and procedures established in Article XV, Variances, of the City Zoning Code, except as otherwise allowed under design relief.

## 1.6 Design Relief to Design Standards

### 1.6.1 Design Relief Criteria

Design relief to the BROD Design Standards may be considered for approval by the Zoning Administrator if the administrator finds that the proposed design changes will accomplish the intent of the BROD as effectively or better as strict compliance with the adopted standards as follows:

- Promotes the development of an urban form that is pedestrian-friendly,
- Provides compatibility with surrounding properties,
- Provides safety and convenience for pedestrians, cyclists, and transit riders,
- Provides safety for vehicular circulation,
- Provides a similar or better design solution that encompasses the design principles described in the BROD Design Standards or historically accepted design practices.

### 1.6.2. Design Relief Application

Applications for design relief shall be uploaded to the City's online application portal. The application consists of a letter along with drawings, as necessary, from the applicant that describe the requested design relief. The letter must describe the hardship created by the required design standard and the proposed minimum change to the design standard to relieve the hardship. If the original application was for site plan approval, then the design relief application must be uploaded to the site plan application file, and similarly for other application types. The sections of the Becker Road Overlay district (BROD) Design Standards that are eligible for the design relief process are listed below. Any items not listed below require a variance.

### 1.6.3 Design Relief Changes Subject to Approval by Zoning Administrator

~~The Zoning Administrator may consider for approval the following proposed design relief changes subject to review under Section 1.6.1 above. Proposed design relief changes to the BROD Design Standards not listed below require a Variance.~~

1. ~~Relief from Section 3.4.2: **Setbacks and Built-to Zones / Frontage Landscape Buffers** – The Zoning Administrator may allow a 10% reduction to the setback dimensions or allow a 10% increase to the build-to zone / frontage landscape buffer depth. not including setbacks abutting properties with single-family land uses. Example: Increase Buffer Depth: 35 feet maximum setback for build-to zone in conversion area. A 10% increase in build-to zone depth allows 3.5 feet: 35 feet x 10%, or 38.5 feet total maximum depth.~~

~~**Transparency** – Allow up to a 5% reduction in the window transparency area required, provided that no~~

less than 15% transparency is provided. The Zoning Administrator may require other design elements as a substitution for reduced transparency.

**Activity Center Building Height** – Allow an increase of up to 5 feet in height in the Activity Center upon finding that the portion of the building exceeding 35 feet is located at least 75 feet from the nearest single-family residential lot outside of the BROD area.

**Building Color** – Allow the use of light to medium shades of pastel colors not specified in the Citywide Design Standards. Allow up to 20% of the building and trim colors to be more intense and saturated, including black, including colors not in the Citywide Design Standards. See Section 4.5 (Building Color).

2. **Relief from Section 3.4.6.1.d - Fueling Station Canopy:** The Zoning Administrator may allow an increase to the length of a fueling station canopy by up to 3-feet.

3. **Relief from Sections 3.7.2.J, 3.8.2.J, 3.9.2.G, 3.10.2.I, 3.11.3.I - Building Frontage Length:** The Zoning Administrator may allow a decrease to the required minimum building frontage length of up to 10%. Example: 40% frontage required – 10% design relief reduction = 30% building frontage with design relief.

4. **Relief from Sections 3.7.5.Q, 3.8.4.R, 3.9.4.L, 3.10.4.N, 3.11.5.N - Transparency:** The Zoning Administrator may approve up to a 30% reduction to the required window and door transparency requirement. See below. On the side of the building that transparency is reduced, the Zoning Administrator may require the amount of required perimeter building landscaping to be increased by up to 30% . Example: 10 trees required x 1.3 = 13 trees. Includes shrubs and groundcover also.

Example: 20% transparency requirement at 30% reduction = 14%, or 6% reduction (.3 x 20 = 6%).

1. 30% transparency requirement may be reduced to 21%
2. 20% transparency requirement may be reduced to 14%
3. 10% transparency requirement may be reduced to 7%

5. **Relief from Sections 3.7.3, 3.8.3, 3.9.3, 3.10.3, 3.11.4 - Building Height:** The Zoning Administrator may approve a reduction of up to 2 feet to the required 22-foot minimum building height based on whether the proposed elevations address the design principles of proportion, scale, harmony, and detailing as described in Chapter 12 of the Citywide Design Standards. The Zoning Administrator may allow an increase of up to 5 feet in height in the Activity Center upon finding that the portion of the building exceeding 35 feet is located at least 75 feet from the nearest single-family residential lot outside of the BROD area.

6. **Relief from Section 4.4 - Articulation:** The Zoning Administrator may allow the maximum spacing distance of the building articulation features as indicated in Section 4.4 (Architectural) to extend an additional 10 feet provided the proposed elevations address the design principles of proportion, scale, harmony, and detailing as described in Chapter 12 of the Citywide Design Standards.



**7. Relief from Section 4.5 - Building Color:**

1. **2% or 5% Trim Color Area Allowance:** The Zoning Administrator may allow the 2% Trim Color Area to be increased to a maximum of 4% of the building face area and may allow the 5% Trim Color Area to be increased to a maximum of 10% of the building face area. See Citywide Design Standards, Chapter 9 (Building Colors).
2. **20% Accent Color Area Allowance:** The Zoning Administrator may allow the Accent Color Area to be a maximum of 30% of the building face area. See Citywide Design Standards, Chapter 9 (Building Colors).

## ~~1.7 Alternative Design Standards~~

~~Alternative design standards may be considered based on exceptional design. The intent is to allow and encourage innovative and creative design. Proposals will only be considered in conjunction with a Planned Unit Development (PUD) zoning or PUD amendment application. To qualify for PUD zoning, a parcel must be at least 1.8 acres in size. The following criteria shall be addressed:~~

- ~~• Logic of design;~~
- ~~• Exterior space utilization;~~
- ~~• Attractiveness;~~
- ~~• Materials selection;~~
- ~~• Compatibility with surrounding properties;~~
- ~~• Circulation and parking—vehicular and pedestrian;~~
- ~~• Accepted architectural principles;~~
- ~~• Design minimizes environmental impact;~~
- ~~• Walkability and Livability.~~

~~The PUD may not alter the following features of the Becker Road Overlay District (BROD) Design Standards: 1) Parking may not be located in front of buildings located along Becker Road, Port St. Lucie Boulevard, or the side streets. 2) The minimum depth of the building frontage landscape buffer shall be maintained. 3) The requirement for a building frontage sidewalk shall be maintained. See Section 5.4.2 (Landscaping).~~

### ~~1.7.1 Application Requirements:~~

- ~~• Letter addressing all of the above criteria;~~
- ~~• Fee (includes the sum of the PUD rezoning or amendment and architectural design fees);~~
- ~~• PUD rezoning or amendment application;~~
- ~~• Color elevations; and~~
- ~~• Perspective color drawing/s.~~

~~In the PUD document, one section shall be dedicated to the Alternate Design Standards which shall include architectural design standards. The Alternative Design Standards will be reviewed in conjunction with Sections 158.170-183, of the City PUD Zoning Code, except as otherwise required in the BROD Design Standards. See Section 6.4 (Parking).~~

## 1.7 Definitions

**Accessory Use or Structure** - A use or structure of a nature customarily incidental and subordinate to the principal use or structure and, unless otherwise provided, on the same lot.

**Arcade or Colonnade** - An attached linear hallway that is open and flanked with columns or pillars. The arcade or colonnade shall be consistent with the style and proportions of the building to which it is attached and have support columns spaced no greater than 1.5 the height of the column. A pitched roof or a flat roof (with optional open-air deck and railing) is permitted above the arcade or colonnade. A sidewalk that passes through an arcade or colonnade shall have a minimum clear width of 5 feet. See Section 3.5 (Encroachments).

**Architectural Wall** - A wall designed to complement adjacent development consisting of masonry block with stucco, fluted block, a finished designer block, poured concrete, or pre-cast concrete with a treatment on top such as a cornice, tile band, or similar accent. A pre-cast concrete wall shall be comparable in visual quality to a block wall.

**Awning** - A fixed or moveable building accessory that projects from a wall and consists of canvas, wood, metal, or other material that is used to keep the sun or rain off of a storefront, window, or doorway. The awning may also be used primarily as a decorative element.

**Bahama Shutter** - A single exterior window covering or awning that is hinged at top, made from framed horizontal louvers.

**Balcony** - A platform enclosed by a wall or balustrade on the outside of a building with access from an upper-floor door typically. Balconies shall be a minimum of three feet deep and five feet wide.

**Becker Road Corridor** - Refers to development located within the Becker Road Overlay District as depicted on Map 2-1.

**BROD** - Becker Road Overlay District

**Building Coverage** - Building coverage applies to all buildings including accessory structures. The total of areas taken on a horizontal plane at the main grade of the principal building and all accessory buildings, exclusive of uncovered patios, decks, walkways, terraces, and other similar features. All dimensions shall be measured from the outside face of the exterior wall, slab, or supporting columns.

**Building Entrance** - An entrance that is accessible to customers, patrons, members, visitors, clients, or residents. Does not include entrances intended for service use or employees only.

**Building Façade** - The exterior wall, face, or columns of a building. See ~~Façade~~.

**Building Frontage** - The cumulative width of a building(s) on a lot measured in a straight line parallel with the adjacent street. Building frontage is measured as a percentage as follows: width of building(s) / width of lot. Building frontage may also include outdoor eating areas covered by roof or second floor of building, not including corner plazas that extend beyond the end of building. ~~minus the access driveway, landscaping, and sidewalk width. The minimum access driveway width shall be 40 feet including sidewalks and landscaping.~~ See Chapter 3.0 (Subdivisions & Buildings), ~~Section 3.4.5 (Frontage)~~, and Section 7.3 (Parking).

**Building Height (Overall Height)** - Buildings must comply with maximum height regulations, as measured in both feet and by the number of stories. Overall building height is measured as set forth in 153.01(C) of the City Zoning Code. Except as indicated in Section 1.6.2.5 (Design Relief), buildings with a maximum of two stories are permitted in the BROD.

**Building Type** - A structure defined by the combination of configuration, form, and function. Refer to Chapter 3.0 (Building Types) for the required features of the various permitted building types.

**Build-to Zone** - The minimum and maximum setback distance from a property line that a building façade must be located, thus ensuring a uniform, or more or less even, building façade alignment along the street. All buildings facing a street are subject to the build-to zone as described in Chapter 3.0 (Subdistricts & Building Types). See also Building Façade definition and Section 3.5 (Encroachments).

**Canopy** - A roof-like cover, including an awning, that projects from the wall of a building over a door, entrance, or window. May also be a free-standing structure that projects over an outdoor service area, such as an ATM kiosk, serving the purpose of protecting pedestrians or vehicles from rain and sun, covered with fabric, metal, or other material.

**Common Open Space** - A shared open space amenity for occupants of a development or the public such as, but not limited to, plazas, courtyards, terraces, patios, and greens. See Section 6.0 (Common Open Space).

**Corbel** - A bracket that projects from a wall to support a structure above it. Corbels may be non-structural and decorative.

**Courtyard** - An unroofed area that is completely or mostly enclosed by the walls of a building. Typically, a small-scale living space for property tenants, such as an outdoor gathering area, playground, tot lot, barbeque, pavilion, playing field, or garden. Often, internal to a development and may be privately owned and access controlled.

**Cupola** - Small tower on roof.

**Decorative** - Serving to make something look more attractive; ornamental.

**Design Relief** - Flexibility to modify site or building design standards subject to specific findings.

**Display Window** - Windows located on the ground floor used for the merchandising of goods or services, typically lit from the interior and with exterior architectural detailing.

**Drive-through** - A facility where one can be served without leaving one's car; Typically, service is delivered through a window.

**DUPA** - dwelling units per acre.

**Façade** - See Building Façade.

**Façade Depth Variation** - Recesses and projections on a wall that break up the monotony of the building wall.

**Finished Floor** - The floor height of the first story that may be set against a benchmark elevation.

~~**Form-Based Code** - A means of regulating land development to achieve a specific urban form. Form-based codes foster the development of a predictable urban form and a defined public realm by specifying characteristics of physical form such as building location, height, and building frontage width.~~

**Front Build-to Zone** - See Built-to Zone.

**Frontage** - See Building Frontage.

**Frontage Landscape Buffer** - A landscape buffer that abuts a street right-of-way and is located in front of a building facing a street. See Section 5.4 (Landscaping).

**Frontage Sidewalk** - A sidewalk located within the building frontage landscape buffer. See also Frontage Sidewalk Zone.

**Fueling Station** - Any structure used for the retail dispensing or sale of vehicular fuels; Includes fueling pumps or service island and typically includes a fueling station canopy.

**Fueling Station Canopy** - A permanent structure with a roof and columns that is located above vehicular fueling pumps or service island; Canopies may be freestanding or attached to a commercial building for the purpose of providing shelter to people and automobiles.

**Green** - Exterior lawn space typically designated for passive uses with formally or informally arranged landscaping.

**Landscaped Area** - The area within a parcel containing landscaping, excluding building footprints, paved driveways, parking areas, decks, patios, walkways, and undisturbed natural areas.

**Liner Building** - A shallow structure between 25-30 feet deep, usually placed close to the street frontage. It is typically used to conceal large-scale commercial buildings that do not contribute to a pedestrian-oriented streetscape because the large-scale buildings lack wall articulation, window transparency, and/or multiple points of access. The liner buildings may contain a variety of uses; commercial, office, or residential (on second floor).

**Live-Work Unit** - A dwelling unit within a building combining residential uses on the upper floor with commercial, office, or institutional uses on the ground floor as permitted by the subject zoning district. See Section 3.4 (General).

**Long Side Block** - The longer side of a block that fronts along a primary street. See also “short end block”.

**Lot Area/Width** - Sets the minimum or maximum lot area and width for each building type. Lot width is measured at or parallel to the front property line.

**Major Corner Intersections** - 1) Port St. Lucie Boulevard and Becker Road, 2) Darwin Boulevard and Becker Road, 3) Savona Boulevard and Becker Road.

**Mixed-use** - Multiple uses vertically super-imposed within the same building or horizontally super-imposed across the same development site or same general area through adjacency.

**Mullion** - A vertical element that forms a division between window units.

**Muntin** - A decorative pattern on a window or door consisting of horizontal and/or vertical bars that divide the larger sheet of glass into smaller panes. Sometimes referred to as a grille or grid.

**Outriggers** - An extension of a roof rafter beyond the wall line. Usually a smaller member nailed to a larger rafter to form a roof overhang on a gable end roof. Outriggers may be non-structural and decorative.

**Overall Height** - See Building Height.

**Peaked Roof** – A roof with two or more slopes that rises to a single ridge or point.

**Pitched Roof** – A single sloped roof with a pitch greater than 10 degrees.

**Plaza** - An open area usually located near buildings and often featuring walkways, patios, trees, and shrubs, places to sit, and sometimes shop. Outdoor space for civic, social, and commercial purposes. Activities may include meeting, relaxing, performing, outdoor dining, and special events.

**Porch** - An open-air structure attached to the ground floor of a building forming a covered entrance for residential uses typically.

**Portico** - A structure consisting of a roof supported by columns at regular intervals. Similar to a porch, but typically used for non-residential uses. A pitched roof or a flat roof (with optional open-air deck and railing) is permitted above the portico. Sidewalks that pass through a portico shall have a minimum clear width of 5 feet. See Section 3.5 (Encroachments).

**Primary Building Entrance** - A building entrance that faces a street that is typically used by customers, patrons, or residents to access to a building or a unit within a building.

**Primary Street or Road** - Becker Road or Port St. Lucie Boulevard.

**Regulating Plan** - Includes written and/or graphic documents to enable or preserve the development of a specific urban form. A plan or map of the regulated area designates the locations where various development standards apply.

**ROW** - right-of-way.

**Sash** - A frame holding and encircling the glass in a window.

**Setback** - Indicates the minimum distance that a building or structure may be located from a front, side, or rear yard property line.

**Side Street** – All road other than Port St. Lucie Boulevard and Becker Road. Typically, side streets are 60-feet wide or less, excluding Savona Boulevard and Darwin Boulevard.

**Short End Block** - The shorter side of a block that fronts along a primary street. See also “long side block”.

**Sloped Roof** – A roof that is sloped such as a gable or hip roof.

**Stoop** - Small staircase leading to the entrance of a building that may be covered. Stoops shall have a landing that it at least 3 feet deep and 5 feet wide.

**Storefront** - Features a display window and typically a door with glass on the ground floor of the building with interior uses visible from a street, sidewalk, or other pedestrian way and has an entrance that is accessible to the public.

**Story Height** - The height of story is measured from the floor to the lowest structural member supporting the story above.

**Streetscape** - The visual elements of a street, including the road, adjoining buildings, sidewalks, street furniture, trees and open spaces, etc., that combine to form the street's character.

**Townhouse** - A multifamily dwelling unit constructed in a series or group of attached units.

**Transparency** - A measure of the percentage of glass associated with the windows and/or doors of a building façade . The calculation for the glass area of a window or door includes the vertical and horizontal members



(sash, typically) that encircle the glass of the window or door. ~~Transparency requirements apply to a facade that faces a street or public open space. For additional detail, See Section 4.4.2 (Transparency).~~

**Zoning Acronyms** - General Commercial (CG), Neighborhood Convenience Commercial (CN), Limited Mixed-Use (LMD), Professional (P), Multifamily Residential (RM-5, RM-8), Planned Unit Development (PUD), Open Space Recreational (OSR), Institutional (I), Dwelling Units Per Acre (DUPA).

# 2.0 REGULATING PLAN

## 2.1 Purpose

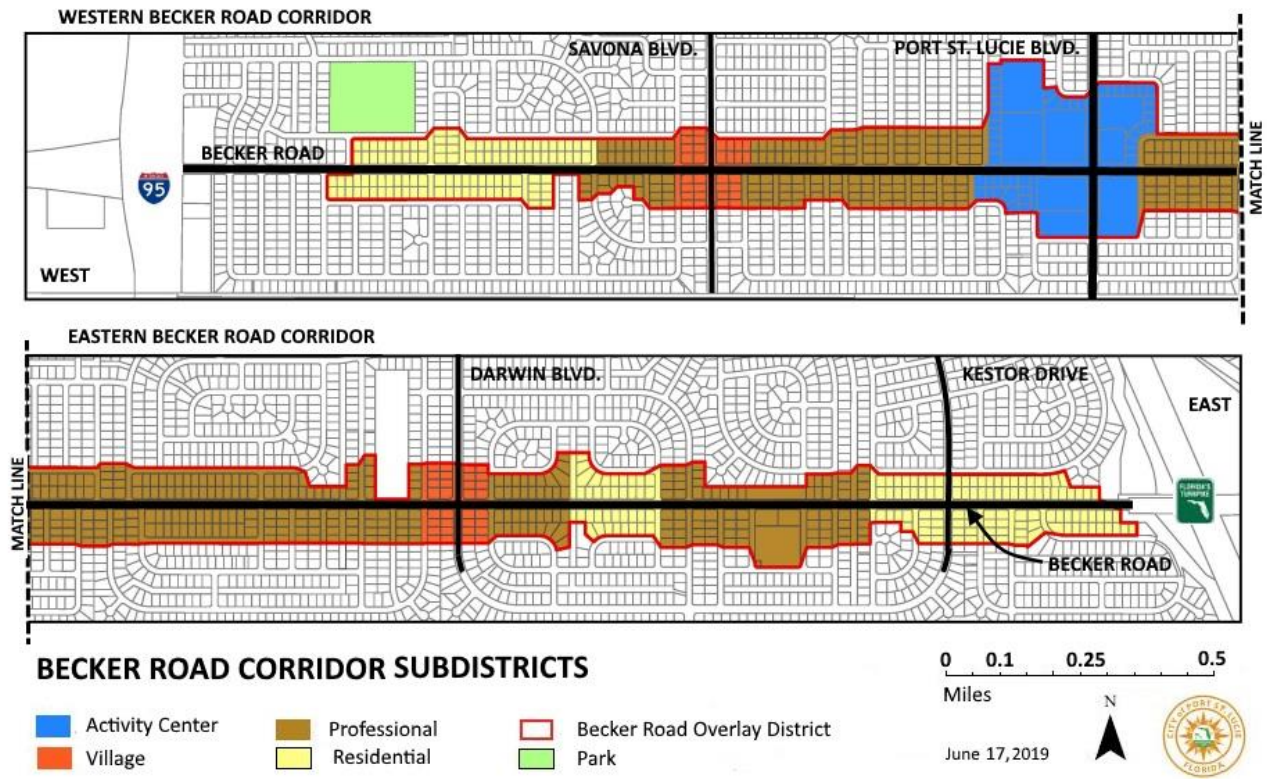
The regulating plan establishes regulations controlling the configuration, features, and functions of a building and site that defines and shapes the public realm along the Becker Road Corridor.

New development and redevelopment located in the Becker Road Corridor is subject to the site design and architectural design standards contained within this document.

## 2.2 Becker Road Subdistricts

The Becker Road Overlay District (BROD) Regulating Plan is divided into four (4) Subdistricts: Residential, Professional, Village, and Activity Center. The boundary and subdistricts for the BROD are identified in **Map 2-1**. This map provides the organizing framework for the design standards herein.

**Map 2-1: Becker Road Overlay District Subdistrict Map**



## 2.3 Prohibited and Allowed Uses

**Refer to the City Zoning Code to obtain a complete list of permitted and conditional uses allowed in a subject zoning district.**

This section identifies a subset of prohibited and allowed uses as related to the City zoning districts within the Becker Road Overlay District (BROD) that are different than the prohibited and allowed uses listed in the City Zoning Code (Chapter 158). These standards also apply to Planned Unit Development (PUD) zoning districts located within the BROD.

<b>2.3.1 PROHIBITED USES</b>	
<b>1) CN (Neighborhood Convenience Commercial)</b>	
	<ul style="list-style-type: none"> <li>a) Service Stations (as a separate use or in conjunction with a permitted use),</li> <li>b) Retail convenience stores with fuel service station,</li> <li>c) Bars, lounges, and night clubs.</li> </ul>
<b>2) CG (General Commercial)</b>	
	<ul style="list-style-type: none"> <li>a) Car wash (full or self-service),</li> <li>b) Bars, lounges, and night clubs,</li> <li>c) Automobile, truck, boat, and/or farm equipment sales,</li> <li>d) Repair and maintenance of vehicles,</li> <li>e) Automobile fuel sales, <u>except as permitted in Section 2.3.3,</u></li> <li>f) Automobile services or repairs, including oil lubrication businesses.</li> </ul>
<b>3) LMD (Limited Mixed-Use)</b>	<del>All zoning districts associated with LMD zoning such as I (Institutional), P (Office), RM-11 (Multiple-Family Residential) are subject to the restrictions of Section 2.3 (Prohibited and Allowed Uses).</del>
	<ul style="list-style-type: none"> <li>a) Model home centers</li> </ul>
<b>4) RM-5 (Multiple-Family Residential-5 DUPA) zoning or PUD zoning with RM (Medium Density Residential) future land use.</b>	
	<ul style="list-style-type: none"> <li>a) Single-family dwelling</li> </ul>
<b>5) I (Institutional)</b>	
	<ul style="list-style-type: none"> <li>a) Cemetery, including mausoleum,</li> <li><del>b) Assisted Living facility as set forth in Chapter 429, Florida Statutes;</del></li> <li><del>c) Community residential home, group care home as set forth in Zoning Code Section 158.224;</del></li> <li>d) Water pumping plant, electrical substation, sewage treatment plant.</li> </ul>

## 2.3.2 ALLOWED USES

1) **CG (General Commercial), CN, (Neighborhood Convenience Commercial), P (Professional), LMD (Limited Mixed-Use) zoning or PUD zoning in MU (Mixed-Use) future land use district.**

- a) **Live-Work Units with residential uses on the second floor.**
  - 1. **Drive-through facilities (banks only).**

## 2.3.3 SPECIAL EXCEPTION USES (SEU)

1) **Activity Center District: General Commercial (CG) or PUD Zoning**

- a) **Fueling Stations:** As per Section 158.124(C)9 of the General Commercial Zoning Code, automobile fueling stations are permitted with SEU approval, except as otherwise prohibited herein. For fueling stations with a convenience store, a combined maximum of 10,000 daily trips as described in the ITE (Institute of Transportation) Manual is allowed for the Activity Center. This is intended to limit the impact of traffic on a pedestrian-oriented development. Compliance with other regulations set forth in the BROD document is also required. See Section 3.4.4.2.a ( A-B Streets).
- b) **Drive-through Facilities:** As per Section 158.124(C)13 of the General Commercial Zoning Code, any use set forth in Subsection B: "Permitted Principal Uses and Structures" is permitted to have buildings with drive-throughs with SEU approval, except as otherwise prohibited herein. For quick-service restaurants with a drive-through, a combined maximum of 6,000 daily trips as described in the ITE (Institute of Transportation) Manual is allowed for the Activity Center. This is intended to limit the impact of traffic on a pedestrian-oriented development. Compliance with other regulations set forth in the BROD document is also required. See Section 3.4.4.2.b ( A-B Streets).
- c) **Side Street Vehicular Access:** Site Plans applications proposing vehicular access from a side street to a property that is in the Activity Center District must obtain approval for a Special Exception Use (SEU). Side street access may create additional traffic along residential streets that are within or border the Activity Center District. However, it may be necessary for some properties to have side street access.

2) **Village and Professional Subdistricts: CG (General Commercial), CN (Neighborhood Convenience Commercial), P (Professional), LMD (Limited Mixed-Use) zoning or PUD zoning in MU (Mixed-Use) future land use district.**

- a) **Drive-through Facilities:** Banks with drive-throughs are permitted with SEU approval.

# 3.0 SUBDISTRICTS & BUILDING TYPES

## 3.0 Purpose

Together, the subdistricts and building types are intended establish a development pattern that will create an attractive, pedestrian-friendly community by specifying the characteristics of physical form such as building location, height, width, transparency, and other features.

## 3.2 Applicability

The subdistrict and building type requirements apply to all proposed development and redevelopment located within the Becker Road Overlay District (BROD). Each building type may house a variety of uses in accordance with the BROD Design Standards and the City land development regulations. See Chapter 158 of the City Zoning Code and BROD Section 2.3 (Prohibited and Allowed Uses) for specific uses for a subject zoning district.

## 3.3 Building Type Overview

Allowable building types for the Becker Road Overlay District (BROD) are described and illustrated in this section. Regulations for lot criteria, building placement, building height, building elements, and parking location are set forth within the text, tables, and diagrams provided for each subdistrict and building type:

- Townhouse
- Multifamily
- Professional - Commercial/Office/Mixed Use
- Activity Center - Commercial/Office/Mixed Use

## 3.4 General Requirements

All subdistricts and building types shall comply with the following requirements:

1. Conversion Areas: Prior to requesting approval of commercial, office, institutional, or multifamily development located along the Becker Road corridor, single-family lots shall be consolidated and rezoned in accordance with the City Land Use Conversion Manual requirements.
2. **Build-To Zones / Frontage Landscape Buffers:** Build-To zones apply to all buildings facing a primary or side street. **The depth of the Build-To Zone and the Frontage Landscape Buffer is the same.**

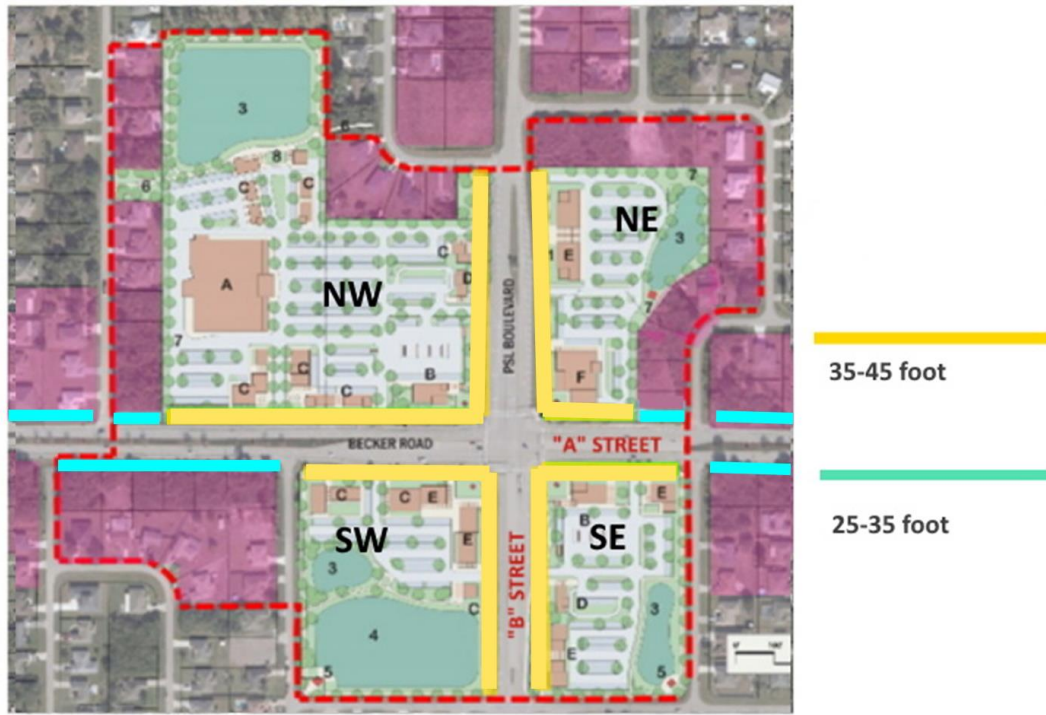
### 1. Primary Street – Build-To Zone / Frontage Landscape Buffer Width

- a) **Activity Center Subdistrict, excluding conversion areas = 35-45 feet,**
- b) **Activity Center Subdistrict, conversion areas only = 25-35 feet,**
- c) **All Other Subdistricts = 25-35 feet**

### 2. Side Street – Build-To Zone / Frontage Landscape Buffer Width

- a) **All Subdistricts = 25-35 feet.**
- 3. **Building Plazas and Common Open Spaces:** Plazas or common open spaces may extend up to 15' behind the build-to zone in order to create a plaza or common open space.

**Figure 3.1. Build-To and Frontage Landscape Buffer Diagram**



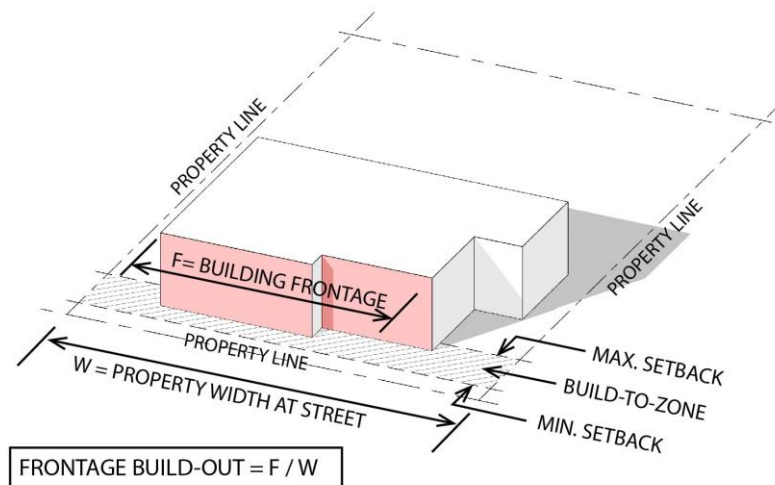
- 3. **Building Frontage and Orientation:** Buildings shall front along a primary street right-of-way and be built parallel to the street right-of-way, ~~and have a building entrance/s that faces a street right-of-way.~~ On parcels of sufficient size, other buildings may be located behind frontage buildings, and shall extend a minimum frontage distance based on the lot width and the minimum percentage of building frontage required for the specific subdistrict.
  - 1. **Side Streets:** Building frontage requirements do not apply to side streets. Buildings may or may not be located along a side street, depending on the building area desired and the parking area required.
  - 2. **Frontage Requirements for Properties in Conversion Areas Less Than 150 Feet in Depth:** Building frontage requirements do not apply to properties in a conversion area facing a primary street that are 150 feet or less in depth. The parking lot shall be permitted to be located to the side of the building facing a primary street. ~~and the minimum street frontage shall not be required. be measured from the edge of the landscape buffer that abuts the parking lot located to the side of a building in the area where the building is to be located.~~



3. **Building Frontage Width Requirement:** The cumulative width of a building(s) on a lot measured in a straight line parallel with the adjacent street. The minimum Building Frontage required is measured as follows:

$$\frac{\text{Width of Building(s)}}{\text{Width of Lot - Width of the access driveway, landscaping, and sidewalk (40 ft. min.)}}$$

**Figure 3-2: Calculating Building Frontage Diagram**



Buildings located in the Professional/Village/Activity Center Subdistricts shall be at least as wide as the minimum building frontage width required along a primary street. Buildings located in the Residential Subdistricts may have building widths that are less than the minimum building frontage width per each building provided the cumulative width is equal to or greater than the minimum building frontage requirement width. See Chapter 3.0 (Subdivisions & Buildings), Section 3.4.5 (Frontage), and Section 6.3.1 (Parking).

**4. Activity Center District - A/B Street Designations and Locations:** In the Activity Center Subdistrict, Becker Road is designated as an “A” Street and Port St. Lucie Boulevard as a “B” Street. This designation is intended to facilitate the development of Becker Road as a more pedestrian-oriented street.

1. **“A” Street** – Allows retail /commercial, restaurant, office, or other uses specified in the applicable zoning district, unless indicated otherwise in Section 2.3 (Prohibited and Allowed Uses). Fueling stations and buildings with drive-throughs shall not be permitted to be located along Becker Road, except for buildings located at the corner of the Becker Road and Port St. Lucie Boulevard intersection.

2. **“B” Street** – In addition to retail /commercial, restaurant, office, and other uses specified in the applicable zoning district, fueling stations and buildings with drive-throughs shall be permitted along Port St. Lucie Boulevard unless indicated otherwise in Section 2.3 (Prohibited and Allowed Uses) or Section 3.4.4.2.b.3 below.

a) **Fueling Stations:** The following standards apply:

1. In the Activity Center Subdistrict, a cumulative maximum of 10,000 weekday trip ends as described in the ITE (Institute of Transportation) Manuel, 11<sup>th</sup> Edition, Code 945, based on the number of fueling positions allowed for fueling stations and convenience stores. This is intended to limit the impact of traffic on a pedestrian-oriented development.
  2. If a fueling station / convenience store is located at one of the corners on Becker Road and Port St. Lucie Boulevard, the fueling station must be located on the interior side of the convenience store or other associated building that is located at the corner. A fueling station shall not be located directly on a corner.
  3. The fueling station canopy must be oriented perpendicular to the street. The fueling station shall not be located in front of a building.
  4. No more than one fueling station canopy is permitted for each fueling station site. The length of the canopy shall not exceed 120 feet.
  5. A fueling station is limited to 8 fueling pumps which allows for 16 stations, one station on each side of a pump.
  6. Fueling Station Design: Refer to the Citywide Design Standards, Chapter 8, for the design requirements for fueling station canopies.
- b) **Drive-throughs:** The following standards apply:
1. **Quick-Serve Restaurants:** In the Activity Center Subdistrict, a maximum of 2,000 weekday trip ends as described in the ITE (Institute of Transportation) Manuel, 11<sup>th</sup> Edition, Code 934, based on square footage is allowed for quick-serve restaurants with a drive-through in each of the four quadrants. This is intended to limit the impact of traffic on a pedestrian-oriented development.
  2. **Pharmacy or Grocery Store:** A pharmacy or grocery store with a drive-through window is permitted along a "B" Street or internal to a site where the building does not front along an "A" street. This is intended to limit the impact of traffic on a pedestrian-oriented development.
  3. If a building with a drive-through is located at the one of the corners on Becker Road and Port St. Lucie Boulevard, the drive-through must be located on the interior side of the building that is located at the corner.
  4. A drive-through window or drive-through stacking-lane must be located to the rear or side of a building that fronts along Port St. Lucie Boulevard. The drive-through window shall not face Port St. Lucie Boulevard or Becker Road.
  5. Each of the four corner quadrants in the Activity Center Subdistrict is permitted to have up to one quick-service restaurant with a drive-through along a B Street. Quick-service restaurants located on the corner of Port St. Lucie and Becker shall orient the longest side of the building along Becker Road.

6. **Building/Parking Location:** Parking lots shall be located to the rear or side of a building facing a primary street, unless indicated otherwise. The longest side of a building shall be oriented along the primary street. See Section 5.9 (Parking Lot Landscape Buffers). Where the depth of a lot in a conversion area facing a primary street is 150 feet or less, a parking lot shall be permitted to be located on the side of the building facing a primary street. Section 7.3.1 (Parking).
7. **Corners at Major Street Intersections:** ~~A primary building entrance to a building located at the corner of a major street intersection shall be oriented toward the corner as a way to give the corner more prominence. Buildings located on Port St. Lucie Boulevard and Becker Road corners shall have a corner plaza as described in Chapter 6 (Common Open Space).~~

~~The corner entrance shall be further enhanced by architectural design features and/or open space. Major street intersections include Becker Road and Port St. Lucie Boulevard, Savona Boulevard, and Darwin Boulevard. See Section 1.6.2.6 (Design Relief). Corner building entrances and corner plazas oriented toward the intersection of primary and local streets are encouraged. The maximum width for a corner plaza or open space that encroaches into the building frontage sidewalk zone and the frontage landscape buffer is 50 feet. See Section 3.5 (Encroachments) and Section 5.1 (Common Open Space).~~

8. **Live-Work Units:** ~~The main entrance to commercial, or office, or residential uses space in live-work units shall may be located at the front, side, or rear of the building facing a street. The entrance to the residential use space may be located on the side or rear of the building. Residential uses shall be located above the ground floor. See Section 2.3.2.1.a (Allowed Uses).~~
9. **Liner Buildings:** Where a building or structure over 25,000 square feet fronts along a street right-of-way or common open space and does not meet the BROD Design Standards due to lack of building transparency or articulation, liner buildings or up to 30% additional perimeter building landscaping shall be required.

**11. Accessory Structures:**

1. Attached accessory structures are considered part of the principal structure.
2. Detached accessory structures are permitted per each building type and shall comply with all setbacks and built-to zones with the following restrictions:
  - a. Detached accessory structures shall be located behind the principal structure in the rear yard, unless indicated otherwise in Section 3.5 (Encroachments).
  - b. Detached accessory structures shall not exceed the height of the principal structure.

12. **Pedestrian and Vehicular Connections and Cross-Access Easements:** Pedestrian and vehicular cross-access to adjacent parcels shall be provided or made possible in the future by the property owner to existing or future development. Cross-access easement(s) shall be granted to abutting property owner(s) for vehicular and pedestrian connections. See Section 7.3 (Parking). A connecting sidewalk shall extend from the sidewalk or multi-use path in the public street right-to-way to a primary building entrance in the shortest distance possible.

13. **Mailboxes:** Mailboxes and mailbox kiosks shall be located in the rear parking lot or driveway area, unless otherwise required by the U.S. Post Office.

14. **Mass Transit Accommodations:** Non-residential/mixed-use buildings greater than 75,000 square feet and residential developments greater than 100 units shall provide at least one bus shelter per development subject to approval by the Public Works Department. The bus shelter design shall

compliment the architectural style of the buildings. Mass transit accommodations shall be provided on properties located in the northeast and the northwest quadrants at the intersection of Becker Road and Port St. Lucie Boulevard subject to approval by the Public Works Department.

15. **Handicapped Ramps:** Ramps for handicap accessibility and fire escapes that are required by the “Accessibility Code”, ADA, 42 USC Chapter 126 shall not be located in front of a building facing a street if it is possible to accommodate ramps on the side or rear of the building yard.
16. **Garbage Cans:** Garbage cans shall be located in the frontage landscape buffer at least every 300 linear feet. Refer to Citywide Design Standards Section 3.0.10 for design requirements.

### 3.5 Encroachments

1. **All Subdistricts:** Every part of a required yard or buffer shall be open and unobstructed from the ground to the sky except as hereinafter provided or as otherwise permitted by this document:
  1. Sills or belt courses may project not over 12-inches into a required yard or buffer,
  2. Cornices, eaves, gutters, movable awnings, or outside utilities may project not over 3-feet into a required yard or buffer,
  3. Chimneys, fireplaces, or pilasters may project not over 2-feet into a required yard or buffer.
  4. Walkways and driveways may extend into a yard or buffer as required for access.
  5. Plazas or common open spaces located on building corners at street intersections may be located in the frontage landscape buffer and extend to the street right-of-way.
  6. Bicycle racks, garbage cans, lighting, and bus stops may be located within the frontage landscape buffer.
  7. The display of merchandise shall not be permitted in the frontage landscape buffer.
  8. Balconies, canopies, marquees, stoops, and overhead wall trellises, overhead shutters, awnings, may encroach a maximum of 5 feet into the frontage landscape buffer.
  9. Paved surfaces or common open space may encroach up to 5 feet in depth and up to 25% of building length into the frontage landscape buffer. Benches and tables may be located in this area.
  10. See Chapter 6.0 (Common Open Space) for permitted encroachments at street corner intersections.
2. **Activity Center Subdistrict, Frontage Landscape Buffer, Excluding Conversion Areas:**
  1. Colonnades, porticos, and porches may encroach a maximum of 5 feet into the frontage landscape buffer.
  2. Paved surfaces or common open space may encroach up to 10 feet in depth and up to 25% of building length on an “A” street. Benches, tables, and umbrellas may be located in this area. See Chapter 6.0 (Common Open Space) for permitted encroachments at corner intersections.

**Walkways and Driveways:** Walkways and driveways may extend into a frontage landscape buffer or frontage sidewalk zone as required for access. Sidewalks and driveways may not encroach into a landscape buffer that abuts a Low-Density Residential (RL) land use.

~~building frontage sidewalk zone or building perimeter landscape buffer, except where a building perimeter landscape buffer occurs within a setback area~~

~~**Arcade, Colonnade, or Portico:** In the Activity Center, Village, and Professional Subdistricts, an arcade, colonnade, or portico may encroach into the frontage sidewalk zone. Pedestrian access along the frontage sidewalk shall be maintained.~~

~~**Build-to-Zone: Common Open Space at Corners and Front Entrances:** A building façade may extend up to 30 feet outside of a build-to-zone and into the site for the purpose of creating a corner common open space or up to 10 feet for a front entrance common open space for a maximum of 20% of the building façade width or 30 feet, whichever is greater.~~

~~For the encroachment of other building elements, refer to City Code Section 158.214 (Yard Encroachments), except as otherwise indicated in this document. These permitted encroachments apply to the frontage sidewalk zone, building perimeter landscape buffer, and setback area.~~

### 3.6 Building Types by Subdistrict

**Table 3-1: Building Types by Subdistricts**

Building Types <sup>1</sup>	Subdistricts <sup>2</sup>			
	Residential	Professional	Village	Activity Center
Townhouse	P	<u>P</u>		<u>P</u>
Multifamily	P	<u>P</u>		<u>P</u>
Commercial/Office		P	P	P
Mixed-Use		P	P	P

**Note:** P - Permitted

- 1. Building Types** - See Sections 3.7 through 3.10 (Subdistricts & Building Types)
- 2. Subdistricts** - See Map 2.1 (Subdistrict Map) and Section 2.3 (Subdistrict Zoning).

**Figure 3-3: Examples of Building Types by Subdistrict**



Townhouse



Multifamily



Commercial/Office/Mixed-Use

### 3.6.1 Townhouse Building Type

**Table 3-2: Townhouse Building Types**

Subdistrict	Zoning <sup>1</sup>	Density
Residential Residential <u>Activity Center, Professional</u>	RM-5 <u>Residential PUD</u> <u>LMD</u>	Max. density 5 DUPA Max. density 8 DUPA <u>Max. density 8 DUPA</u>

**1. Zoning Acronym Definitions:** Multiple Family Residential (RM-5) or Planned Unit Development (PUD)

The Townhouse Building Type is a structure consisting of three or more townhouses placed side-by-side and sharing a common party wall, each with its own entrance to the street.

A property for townhouse development may be subdivided and platted into individual residential lots after parcels have been assembled as required by the Land Use Conversion Manual and as required per the City Subdivision regulations, Chapter 156 (Subdivisions Regulations).

**Figure 3-4: Examples of Townhouse Building Type**



Winter Garden, FL



Orlando, FL



Miami, FL



Sarasota, FL



### 3.6.2 Multifamily Building Type

**Table 3-3: Multifamily Building Types**

Subdistrict	Zoning <sup>1</sup>	Density
Residential <u>Residential</u> <u>Activity Center, Professional</u>	RM-5 <u>Residential PUD</u> <u>LMD</u>	Max. density 5 DUPA Max. density 8 DUPA <u>Max. density 8 DUPA</u>

**1. Zoning Acronym Definitions:** Multiple Family Residential (RM-5) or Planned Unit Development (PUD).

The Multifamily Building type consists of two or more dwelling units with one shared entry typically.

**Figure 3-5: Examples of Multifamily Building Type.**



Tampa, FL



Tampa, FL



Orlando, FL



Miami, FL



### 3.6.3 Commercial / Office / Mixed-Use Building Type

**Table 3-4: Commercial, Office, Mixed-Use Building Types**

Subdistrict	Zoning <sup>1</sup>	Density
Activity Center	CG, CN, P, LMD, PUD (includes live-work)	N/A Max. density 8 DUPA
Activity Center	RM-5 Residential PUD	Max. density 5 DUPA Max. density 8 DUPA
Village	CN, CG, P, LMD, PUD (includes live-work)	N/A Max. density 8 DUPA
Professional	CN, P, CG, P, LMD, PUD (includes live-work)	N/A Max. density 8 DUPA
Professional	RM-5 Residential PUD	Max. density 5 DUPA Max. density 8 DUPA

**1. Zoning Acronym Definitions:** General Commercial (CG), Neighborhood Convenience Commercial (CN), Limited Mixed-Use (LMD), Professional (P), Planned Unit Development (PUD), Institutional (I)

The Commercial / Office Building / Mixed Use Building Types includes a mix of potential uses located in the Activity Center, Village, and Professional Subdistricts. A Commercial or Office Building Type consists of a single use (except for buildings with live-work units) and the Mixed-Use Building Type includes at least two different types of uses such as commercial/office, commercial/residential, office/residential.

**Figure 3-6: Commercial/Office Building Type**



Port St. Lucie, FL



Seaside, FL



Winter Park, FL



Fort Pierce, FL

### 3.7 Residential Subdistrict – Townhouse Building Type

For townhouses on individual platted lots, refer to City Zoning Code Section Sec. 158.218. Townhouse Development Requirements, except as otherwise indicated in the BROD Design Standards.

<b>RESIDENTIAL SUBDISTRICT - Townhouse Building Type</b>	
<b>3.7.1 - Lot Criteria <sup>1</sup></b>	
A - Overall Lot Area (min.)	As required per Land Use Conversion Manual
B - Overall Lot Width (min.)	As required per Land Use Conversion Manual
Overall Bldg. Coverage (max.)	40% <u>50%</u>
Overall Impervious Surface (max.)	80% <u>70%</u>
<b>3.7.2 - Building Placement</b>	
C - Primary and Side Street Build-to Zone (min. - max.)	<u>25 ft. - 35 ft.</u>
D - Side Yard Setback (min.) –	<u>15 ft.</u> - abutting properties not in townhouse development
E - Side Setback between Bldg. (min.)	20 ft. between each townhouse grouping
F - Rear Yard Building Setback (min.) – from street or another property	<u>25 ft. from street right-of-way or abutting properties.</u> Conversion Manual setbacks shall supersede this requirement if they are greater.
G – Driveway / Parking Lot Setback from Bldg.(min.)	10 ft.
H - Detached Garage / Accessory Structure Separation from Building (min.)	10 ft.
I - Garage Door Setback from Driveway (min.)	<u>18 <del>25</del> ft. or 5 ft. if additional parking provided within 80 feet of unit and building front entrance faces street or 0' for detached multi-unit garage building.</u>
J - Building Frontage (min.)	60% on Becker Road Min. building frontage requirement not applicable to buildings facing side streets or properties located in conversion areas that are 150 feet or less in depth.
Building Length (max.)	160 ft.
- Townhouse Unit Dwelling Area (min.)	800 sq. ft.
- Townhouse Dwelling Width (min.)	18 ft.
- Townhouses Units Number (min.)	3 units
- Detached Garage (max.)	450 sq. ft./unit
- Accessory Structures – Size (max.)	50 sq. ft/unit- excludes screen enclosure/pool.
- Accessory Structures – Setbacks (max.)	<u>Rear Setback: 10 feet (overall parcel boundary)</u> <u>Rear Setback: 3 feet (townhouse parcel)</u> <u>Side Setback, same as building setback</u>

<sup>1</sup> **Subdivided Lots** - Lots may be subdivided for individual townhouses as specified in City Code, Section 158.218 (Townhouse Requirements).

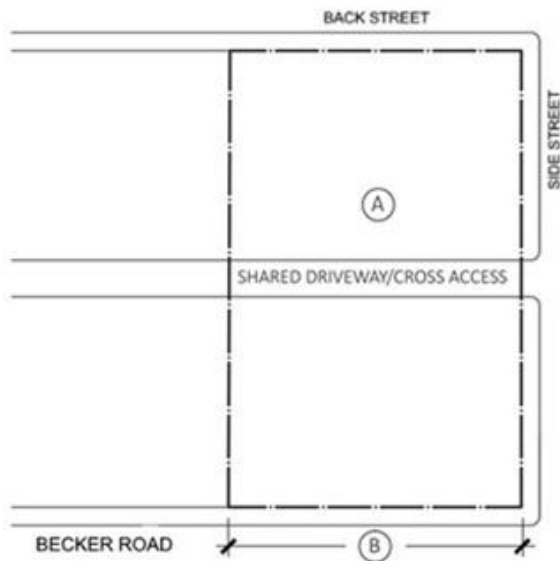


Figure 3-7: Lot Criteria (Townhouse)

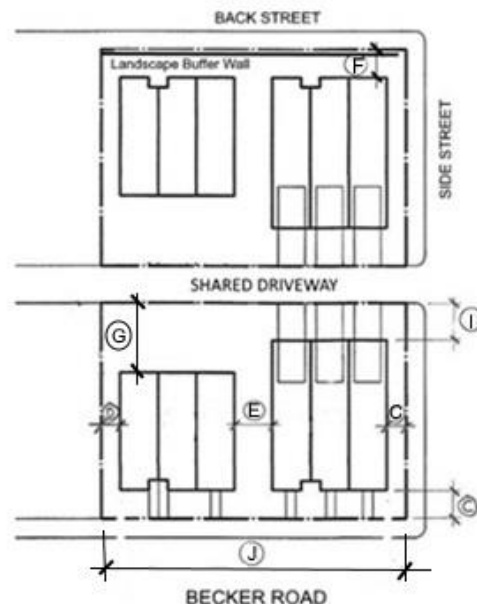
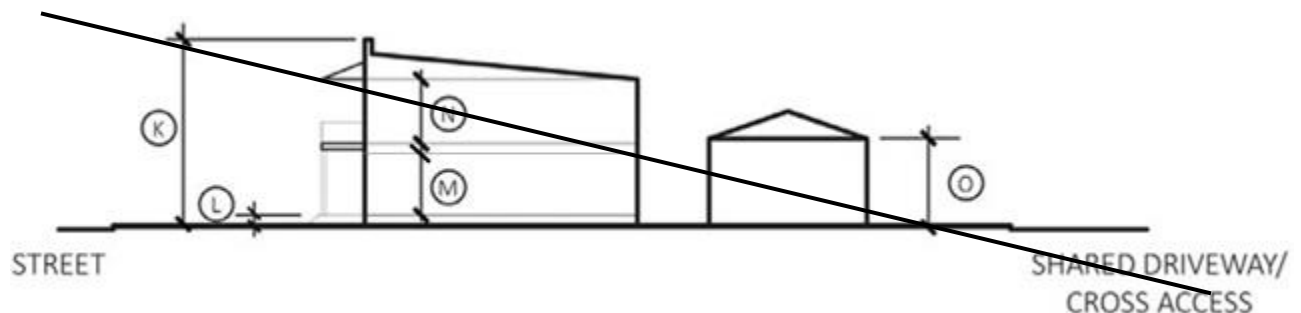


Figure 3-8: Building Placement (Townhouse)

### 3.7.3 – Residential Subdistrict - Building Height

K – Overall Height (max.) Overall Height (min.)	35 ft. (2 story) 22 ft. Buildings fronting Becker Road shall have 2 floors.
Accessory Structures (max.)	Shall not exceed height of the principal structure. See Section 3.4.2.
L – Finished Floor (min.)	Finish floor elevation shall be at least 20" above grade at entrance wall location for façade facing a street with a stoop or porch with steps to front entrance. The rear entrance shall not require 20" floor elevation, steps, stoop, or porch.
M – Ground Floor (min.) N – Second Floor (min.)	8 ft. (floor to ceiling) 8 ft. (floor to ceiling)
Ø Detached Garage (max.)	16 ft. (1 story)

Figure 3-6. Building Height (Townhouse)



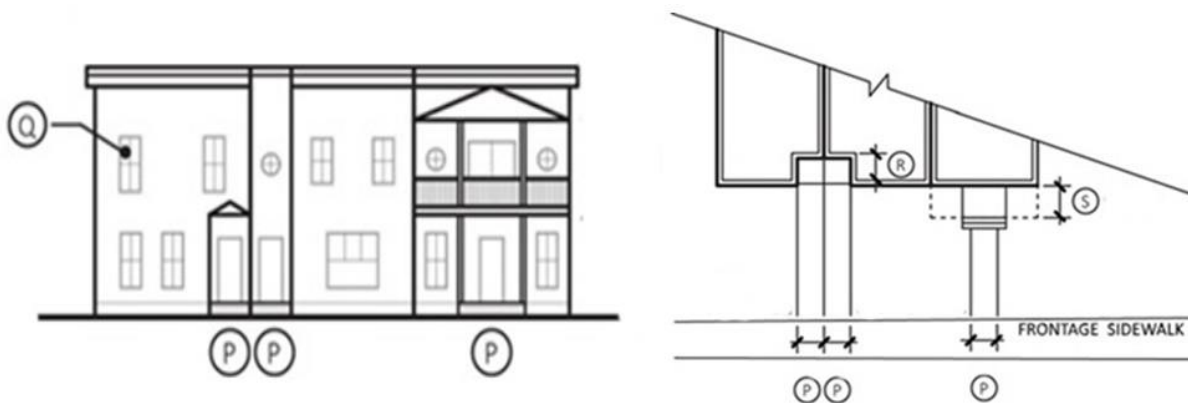
## RESIDENTIAL SUBDISTRICT - Townhouse Building Type

### 3.7.5 Building Elements – See Also, Section 3.4. (General) & Chapter 4.0 (Architecture)

P - Street Entrances (min.)	<p><u>Building Front Façade Facing Primary Street</u> - One street-facing <u>or side</u> entrance per unit. Sidewalks from frontage landscape sidewalk shall extend to front entrance.</p> <p><u>Building Front Façade Facing Side Street</u> - One street-facing <u>or side</u> entrance per unit. Sidewalks from frontage landscape sidewalk <u>or side street sidewalk in right-of-way shall extend to front entrance.</u></p>
Q - Transparency (min.) <sup>1</sup>	15% (ground and upper stories) for front and rear building façades. <del>facing a street or open space.</del>
R - Façade Depth Variation (min.)	1 ft. variation of the front building façade for every 3 townhouses.
- Façade Articulation	See Chapter 4.0 (Architecture).
S - Porch Depth (min.)	6 ft.
- Encroachments	See Section 3.5 (Encroachments).

<sup>1</sup> Where an architectural wall along a side or rear street or adjacent property obscures the view of the ground floor, minimum transparency for ground floor is not required. ~~for ground floor facing rear street.~~

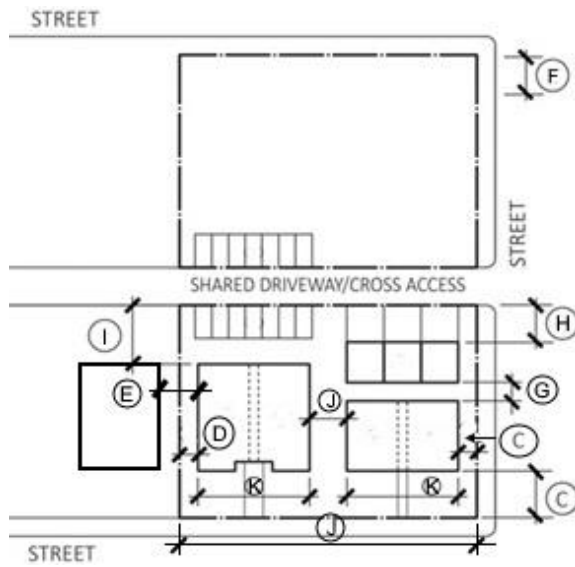
**Figure 3-9: Building Elements (Townhouse)**



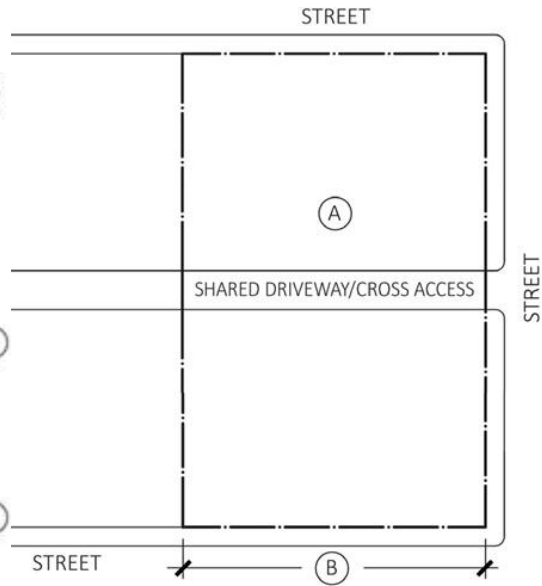
### 3.8 Residential Subdistrict – Multifamily Building Type

<b>RESIDENTIAL SUBDISTRICT - Multifamily Building Type</b>	
<b>3.8.1 - Lot Criteria</b>	
A - Overall Lot Area (min.)	As per Land Use Conversion Manual
B - Overall Lot Width (min.)	As per Land Use Conversion Manual
Overall Bldg. Coverage (max.)	40% <u>50%</u>
Overall Impervious (max.)	80% <u>70%</u>
<b>3.8.2 - Building Placement</b>	
C - Primary and Side Street Build-to Zone (min. - max.)	<u>25 ft. - 35 ft.</u>
D - Side Yard Setback (min.) - abutting properties E - Side Setback between Bldg. (min.)	<u>15 ft.</u> 20 ft. between each multifamily grouping
F - Rear Yard Building Setback (min.) – from street or another property	<u>25 ft. from street right-of-way or abutting properties.</u>  Conversion Manual setbacks shall supersede this requirement if they are greater.
G - Detached Garage / Accessory Structure Separation from Building (min.)	10 ft. from building
H - Garage Door Setback from Driveway	<u>18 25 ft. or 5 ft. if required parking provided within 80 feet of unit and building front entrance faces street or 0' for detached multi-unit garage building.</u>
I - Driveway / Parking Lot Setback (min.) from Bldg.	10 ft.
J - Building Frontage (min.)	60% on Becker Road Min. building frontage requirement not applicable to buildings facing side streets or sites located in conversion area that are 150 feet or less in depth.
K - Building Length (min. - max.) Becker Road Building Length (min. - max.) Side Street	<u>70 ft. - 160 ft.</u> <u>50 ft. - 150 ft.</u>
Multifamily Unit Size (min.)	As per City Zoning Code Section 158.078.
Number of Units (min.)	2 units (duplex). See “K” Building Length above.
Detached Garage (max.)	450 sq. ft./unit
- Accessory Structures – Size (max.) - <u>Accessory Structures – Setbacks (max.)</u>	50 sq. ft./unit- excludes screen enclosure/pool. <u>Rear Setback: 10 feet (overall parcel boundary)</u> <u>Side Setback, same as building setback</u>

**Figure 3-10: Lot Criteria (Multifamily)**

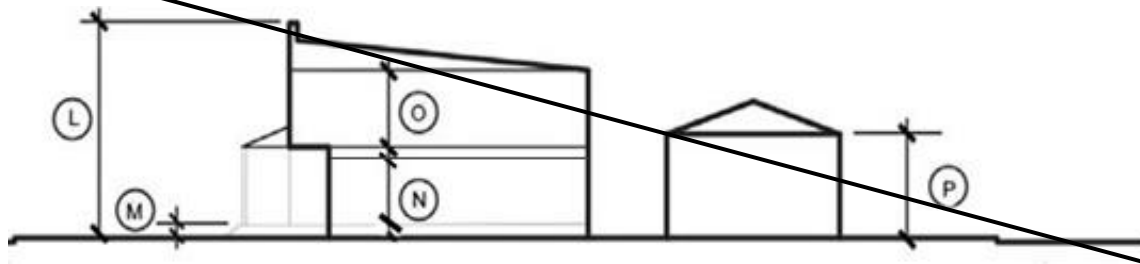


**Figure 3-11: Building Placement (Multifamily)**



<b>RESIDENTIAL SUBDISTRICT - Multifamily Building Type</b>	
<b>3.8.3 - Building Height</b>	
L— Overall Height (max.) - Overall Height (min.)	35 ft. (2 story) 22 ft. Buildings fronting Becker Road shall have 2 floors.
- Accessory Structures	Shall not exceed height of principal structure. See Section 3.4.2.
M— Finished Floor (min.)	Finish floor elevation shall be at least 20" above grade at entrance wall for façade facing street with a stoop or porch with steps to front entrance. The rear entrance shall not require 20" floor elevation, steps, stoop, or porch.
N— Ground Floor (min.)	8 ft. (floor to ceiling)
O— Second Floor (min.)	8 ft. (floor to ceiling)
P— Detached Garage (max.)	16 ft. (1 story)

**Figure 3-10. Building Height (Multifamily)**



## RESIDENTIAL SUBDISTRICT - Multifamily Building Type

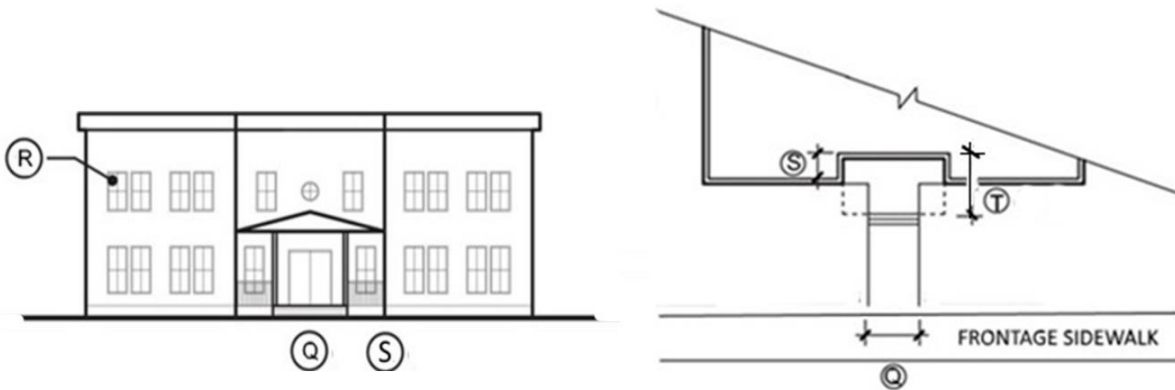
### 3.8.4 - Building Elements – See Also, Section 3.4.4 (General), Chapter 4.0 (Architecture)

Q - Street Entrances (min.)	<p>Building Front Façade Facing Primary Street - One street-facing <u>or side</u> entrance per unit. Sidewalks from frontage landscape sidewalk shall extend to front entrance.</p> <p>Building Front Façade Facing Primary Street - Sidewalks from frontage landscape buffer or side street sidewalk in right-of-way shall extend to front entrance.</p>
R - Transparency (min.) <sup>1</sup>	<p>20% (ground and upper stories) for front and rear building façades facing a street or open space</p> <p>10% (building sides)</p>
S - Façade Depth Variation (min.)	1 ft. depth every 60 linear ft. See Chapter 4.0 (Architecture).
- Façade Articulation	See Chapter 4.0 (Architecture).
T - Porch Depth (min.)	6 ft.
- Encroachment	See Section 3.5 (Encroachments).

1.

Where an architectural wall along a rear street or adjacent property obscures the view of the ground floor, minimum transparency for ground floor is not required. ~~for ground floor facing rear street.~~

**Figure 3-12: Building Elements**



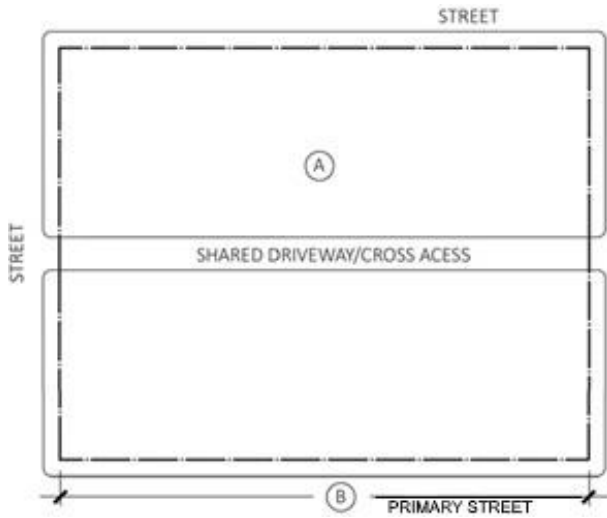
### 3.9 Professional Subdistrict – Commercial/Office/Mixed Use Building Types

<b>PROFESSIONAL SUBDISTRICT - Commercial/Office/Mixed-Use Building Types</b>	
<b>3.9.1 - Lot Criteria</b>	
A - Overall Lot Area (min.)	As required per Land Use Conversion Manual
B - Overall Lot Width (min.)	As required per Land Use Conversion Manual
Overall Bldg. Coverage (max.)	40%
Overall Impervious Surface (max.)	80%

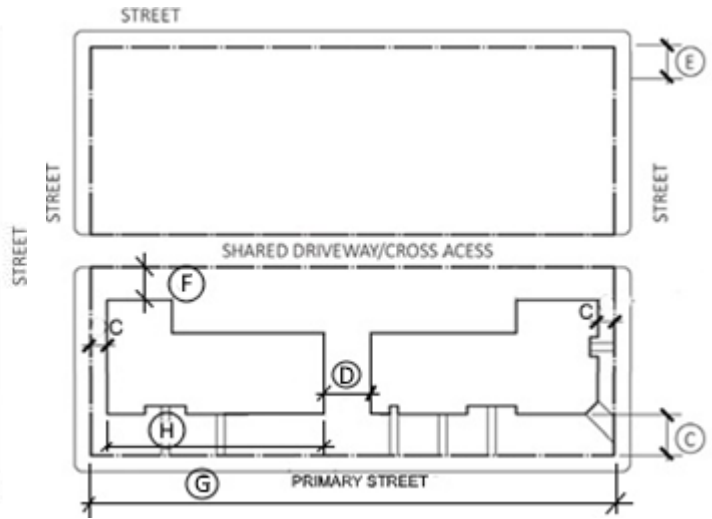
<b>3.9.2 - Building Placement</b>	
C - Build-to Zone	<del>20-23</del> 25-35 ft. – primary and side streets
- Side Yard Setback (min.) - abutting properties	10 ft.
D - Setback between Buildings (min.)	20 ft.
E - Rear <u>Yard</u> Setback (min.)	25 ft. from a street right-of-way. <u>15 ft, from an abutting property</u> <u>25 ft from abutting property if the abutting property has a residential future land use.</u> Conversion Manual setbacks shall supersede this requirement if they are greater.
- Accessory Structure Separation from Bldg.	10 ft.
F - Driveway / Parking Lot Setback from Bldg. (min.)	10 ft. - excluding access to drive-throughs and service areas.
G - Building Frontage (min.)	<del>75</del> <u>50</u> % (primary streets)  Min. building frontage requirement not applicable to buildings facing side streets or properties in conversion areas that are 150 feet of less in depth.
H - Building Length ( <del>min. – max.</del> ) Primary Street <del>— Building Length (min. – max.) Side Street</del>	<del>Minimum building frontage width (min.) – 500 ft. (max.) No more than one building. 40 ft. – 300 ft.</del>



**Figure 3-13: Lot Criteria (Professional)**



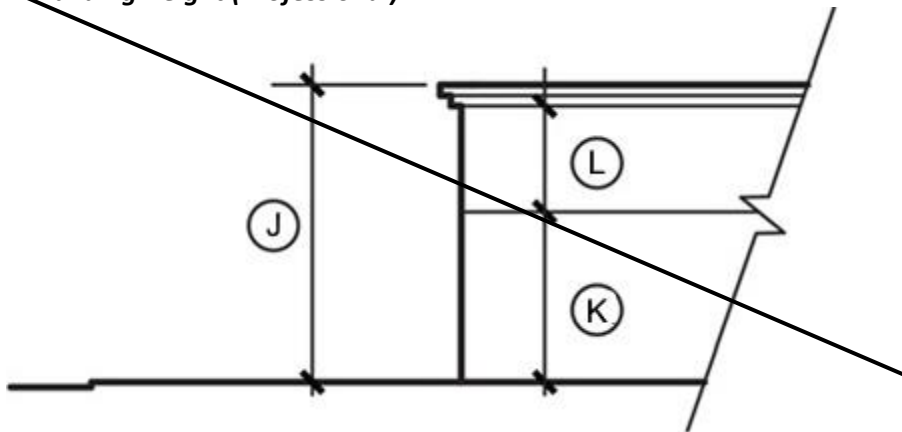
**Figure 3-14: Building Placement (Professional)**



### 3.9.3 - Building Height

J- Overall Height (max.)	35 ft. (limited to 2 stories)
- Overall Height (min.)	22 ft.
- Accessory Structure Height (max.)	Shall not exceed height of principal structure.
K- Ground Story Height (min.)	14 ft. (1 <sup>st</sup> floor to 2 <sup>nd</sup> floor)
L- Second Floor (min.)	9 ft. (floor to ceiling) non-residential 8 ft. (floor to ceiling) residential

**Figure 3-14: Building Height (Professional)**



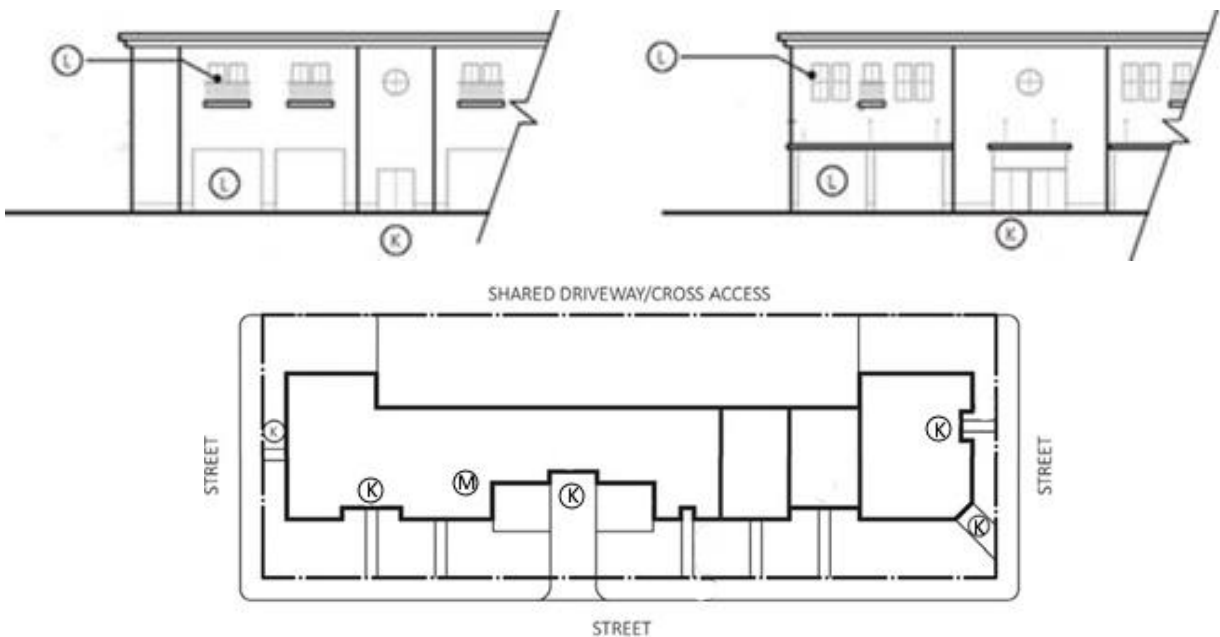
**PROFESSIONAL SUBDISTRICT  
Commercial/Office/Mixed-Use Building Types**

**3.9.4 - Building Elements – See Also, Section 3.4.4 (General), Chapter 4.0 (Architecture)**

<p>K - <u>Street Primary Entrance/s</u> on Ground Floor (min.)</p>	<p><u>Faces primary street, side street, or rear or side of building. Sidewalks shall connect entrances to sidewalk in street right-of-way.</u></p> <p><b>Office or Institutional Uses:</b> At least one street-facing or side entrance for each building.</p> <p><b>Commercial Uses:</b> At least one street-facing or side-entrance for each unit in a multi-tenant building. At least one street-facing or side-entrance for single tenant-building.</p>
<p>L - Transparency <sup>1</sup></p>	<p><u>30% - Ground floor facing primary street or corner street.</u></p> <p><u>15% - All other ground floor façades facing a parking lot, driveway, or common open space.</u></p> <p><u>20% - All second floor.</u></p>
<p>M - Façade Depth Variation (min.)</p>	<p>1 ft. offset depth every 100 ft.</p>
<p>- Façade Articulation</p>	<p>See Chapter 4.0 (Architecture).</p>
<p>N - Canopies, Marquee- — Height (min.)</p>	<p>8 ft. clear height above ground-level-</p>
<p>- Encroachments</p>	<p>See Section 3.5 (Encroachments).</p>

1. Where an architectural wall located along the side or rear of a property obscures the view of the ground floor, minimum transparency is not required for ground floor.

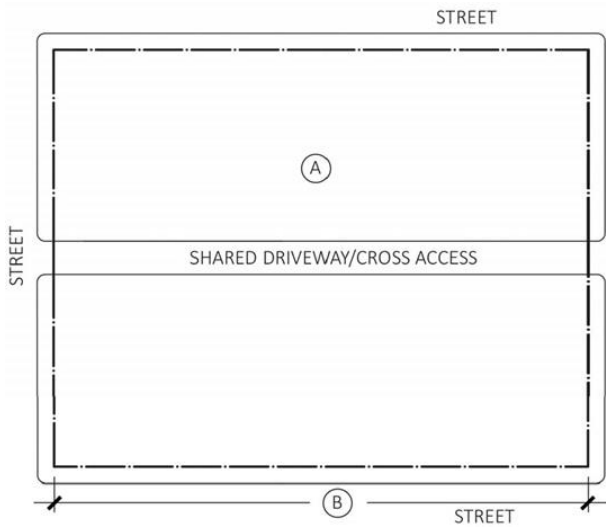
**Figure 3-15: Building Elements (Professional)**



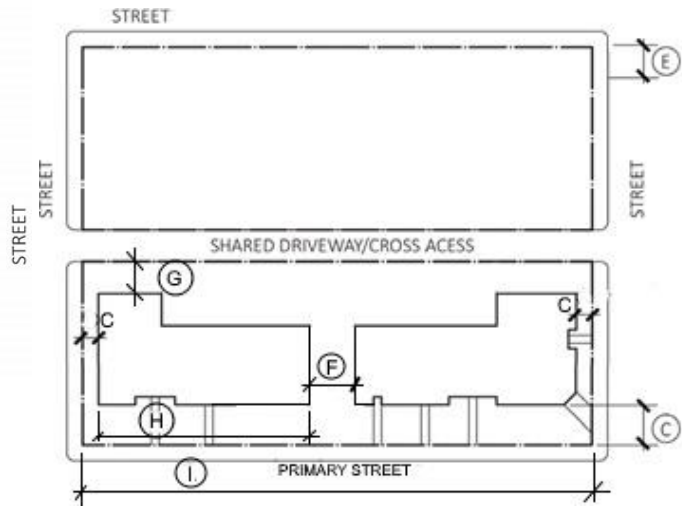
### 3.10 ~~Activity Center~~ & Village Subdistrict - Commercial / Office / Mixed-Use Building Types

<b>VILLAGE SUBDISTRICT - Commercial/Office/Mixed-Use Building Types</b>	
<b>3.10.1 - Lot Criteria</b>	
A - Overall Lot Area (min.)	As required per Land Use Conversion Manual
B - Overall Lot Width (min.)	As required per Land Use Conversion Manual
Overall Building Coverage (max.)	40%
Overall Impervious Surface (max.)	80%
<b>3.10.2 - Building Placement</b>	
C - Build-to Zone (min. - max.)	22 ft. <del>→</del> <u>25-35</u> ft. - primary and side streets
D - Side Yard Setback (min.) - abutting properties	10 ft.
E - Setback between Building (min.)	20 ft.
F - Rear Yard Setback (min.)	<u>25 ft. from a street right-of-way.</u> <u>15 ft. from an abutting property .</u> <u>25 ft from abutting property if the abutting property has a residential future land use.</u> <u>Conversion Manual setbacks shall supersede this requirement if they are greater.</u>
Accessory Structure Offset from Bldg.	10 ft.
G - Driveway / Parking Setback from Bldg. (min.)	10 ft. - excluding access to service areas and drive-throughs.
H - Building Length ( <del>min.</del> max.)	<u>500</u> ft. (max.)
I - Building Frontage (min.) Primary Street	<del>70</del> <u>40</u> %  Minimum building frontage requirement are not applicable to buildings facing side streets or properties located in a conversion area that are 150 feet or less in depth.

**Figure 3-16: Lot Criteria (Activity Center / Village)**

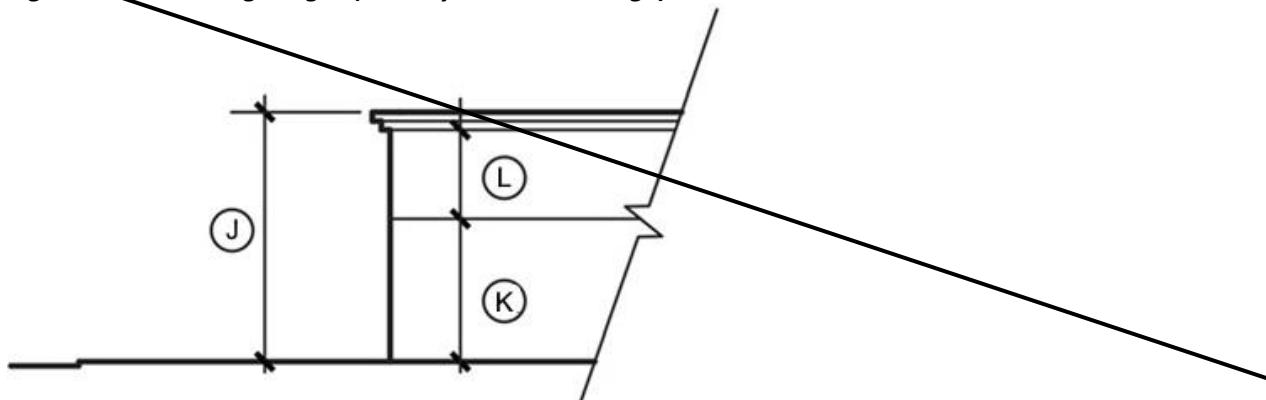


**Figure 3-17: Building Placement (Activity Center)**



<b>3.10.3 - Building Height</b>	
J - Overall Height (max.)	35 ft. (limited to 2 stories, except as indicated in Section 1.6.2.3 (Design Relief).
- Overall Height (min.)	22 ft.
- Accessory Structure Height (max.)	Shall not exceed height of principal structure. See Section 3.4.13 (Accessory Structures).
K - Ground Story Height (min.)	14 ft. (1 <sup>st</sup> floor to 2 <sup>nd</sup> floor)
L - Upper Floor (min.)	9 ft. (floor to ceiling) non-residential 8 ft. (floor to ceiling) residential

**Figure 3-18: Building Height (Activity Center & Village)**



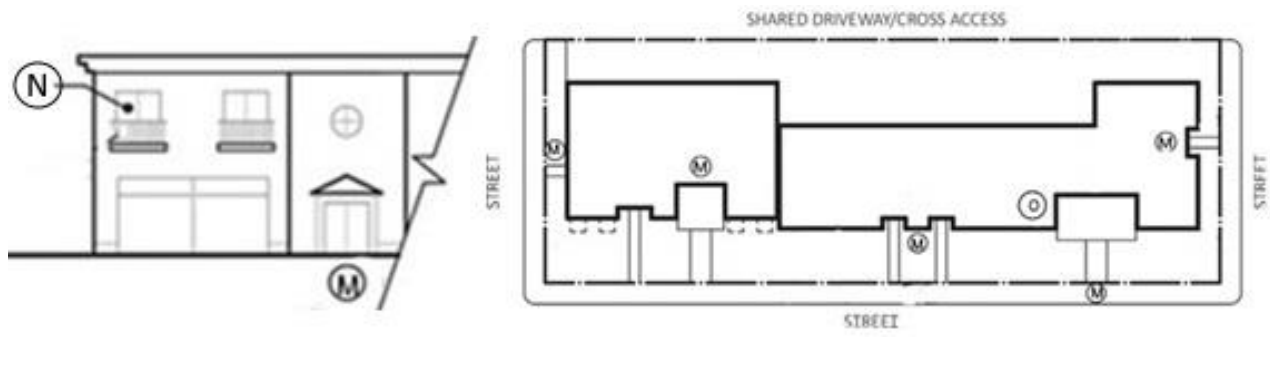
**ACTIVITY CENTER & VILLAGE SUBDISTRICT**  
**Commercial/Office/Mixed-Use Building Types**

**3.10.4 - Building Elements – See Also, Section 3.4.4 (General), Chapter 4.0 (Architecture)**

<p>M - <del>Street</del> Main Customer Entrance on Ground Floor (min.)</p>	<p>Entrances may face a primary street, side street, or rear or side of building. Sidewalk from frontage landscape buffer shall connect to building entrance.</p> <p><b>Office or Institutional Uses:</b> One street-facing entrance (min.) for each building.</p> <p><b>Commercial Uses:</b> At least one street-facing or side-entrance (min.) for each unit in a multi-tenant building. At least one street-facing or side-entrance for single-tenant building.</p>
<p>N - Transparency (min.) <sup>1</sup></p>	<p>30% - Ground floor facing primary street.</p> <p>15% - Rear ground floor façades facing a parking lot, driveway, or common open space.</p> <p>20% - All second floor.</p>
<p>O - Façade Depth Variation (min.)</p>	<p>1 ft. offset depth at least every 100 ft.</p>
<p>- Façade Articulation</p>	<p>See Chapter 4.0 (Architecture).</p>
<p><del>Canopies, Marquee</del>  <del>Height (min)</del>  <del>Depth (min.)</del></p>	<p>8 ft. clear height above ground level;          5 ft. deep when located over frontage sidewalk to protect pedestrians from rain.</p>
<p>- Encroachments</p>	<p>See Section 3.5 (Encroachments).</p>

1. Where an architectural wall located along the rear or side of a property obscures the view of the ground floor, transparency is not required for ground floor.

**Figure 3-18: Building Elements (Activity Center & Village)**

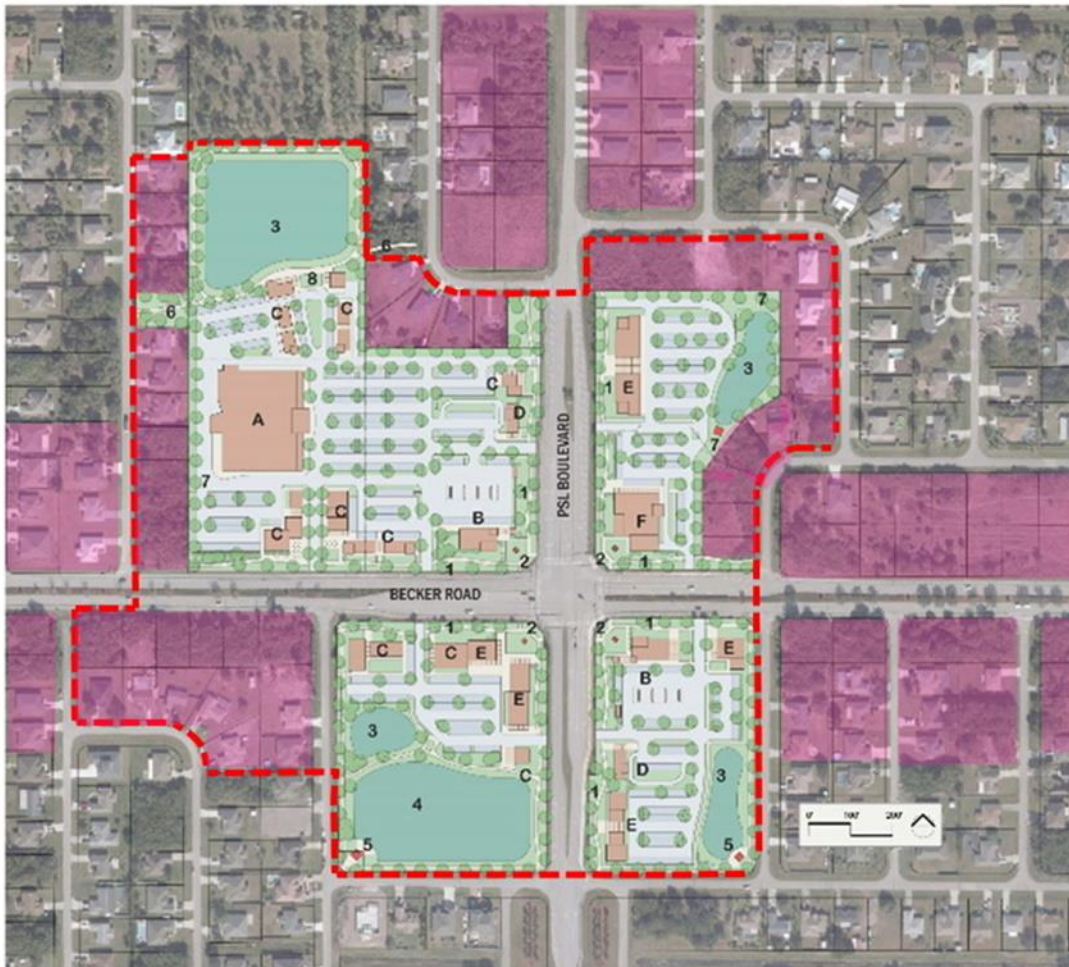


### 3.11 Activity Center Subdistrict

#### Commercial / Office / Mixed-Use Building Types

**Figure 3-19. Activity Center Subdistrict Conceptual Master Plan.**

The Conceptual Master Plan is an example of how development could occur in the Activity Center Subdistrict according to the Becker Road Overlay District (BROD) Design Standards.



#### PROPOSED SITE IMPROVEMENTS

1. LANDSCAPED BUILD-TO LINE (45-50 FEET) WITH MEANDERING BIKE/PEDESTRIAN PATH
2. CORNER GREENSPACE WITH PUBLIC ART
3. SHARED STORM WATER DETENTION
4. IMPROVED CITY-OWNED STORM WATER WITH PARK IMPROVEMENTS
5. COVERED OUTDOOR STRUCTURE WITH SEATING
6. PROPOSED PEDESTRIAN CONNECTION TO EXISTING NEIGHBORHOOD
7. STUB OUT FOR FUTURE CONNECTION
8. PLACEMAKING OPPORTUNITY OVERLOOKING AMENITIZED STORM WATER

#### PROPOSED USES

NOTE: Proposed uses are representative and not necessarily site-specific.

- A. GROCERY STORE
- B. GAS STATION / CONVENIENCE STORE
- C. COMMERCIAL / RETAIL / RESTAURANT
- D. FAST FOOD
- E. OFFICE
- F. CHAIN DRUGSTORE

-  Activity Center Subdistrict
-  Conversion Areas



## ACTIVITY CENTER - Commercial/Office/Mixed-Use Building Types

### 3.11.2 - Lot Criteria

A - Overall Lot Area (min.)	As required per Land Use Conversion Manual
B - Overall Lot Width (min.)	As required per Land Use Conversion Manual
Overall Building Coverage (max.)	40%
Overall Impervious Surface (max.)	80%

### 3.11.3 - Building Placement

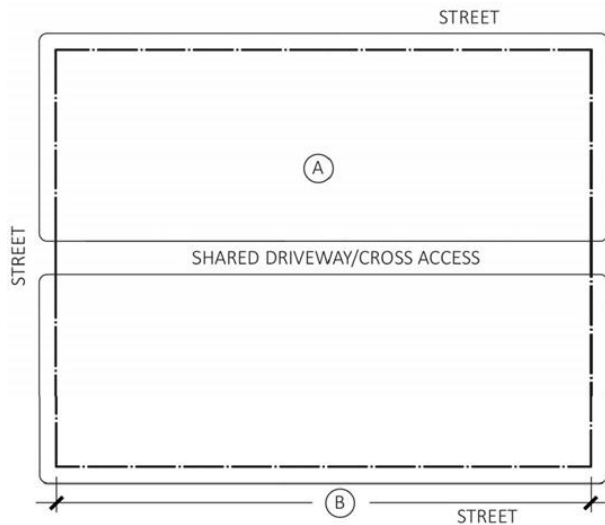
C - Build-to Zone (min. - max.)	35 - 45 ft. - primary streets, excluding conversion areas. 25-35 ft. - side streets and all conversion areas.
D - Side Yard Setback (min.) - abutting properties	10 ft. 25 ft. from abutting property if the abutting property has a residential future land use.
E - Rear Yard Setback (min.)	25 ft. from a street right-of-way. 15 ft. from an abutting property . 20 ft. from abutting property if the abutting property has a residential future land use. Conversion Manual setbacks shall supersede this requirement if they are greater.
F - Separation between Building (min.)	20 ft.
Accessory Structure Offset from Bldg.	10 ft.

Figure 3-20. Example: Retail Building Facing Becker Road or Port St. Lucie Boulevard.

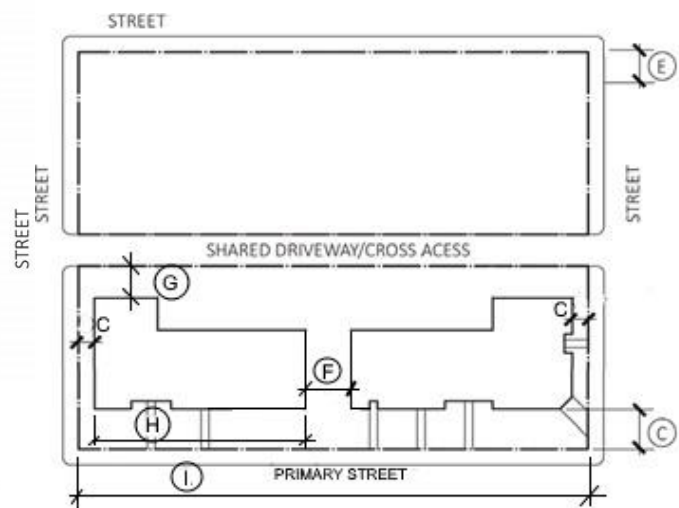


<u>G - Driveway / Parking Setback from Bldg. (min.)</u>	<u>10 ft. - excluding access to service areas and drive-throughs.</u>
<u>H- Building Length (max.)</u>	<u>500 feet</u>
<u>I - Building Frontage (min.)</u>  <u>Type "A" Streets</u>  <u>Type "B" Streets</u>	<u>Type A - 40% for each parcel</u>  <u>Type B - 30% for each parcel – A fueling station canopy does not qualify as building frontage.</u>  Minimum building frontage requirements are not applicable to buildings facing side streets or properties located in a conversion area that are 150 feet or less in depth.

**Figure 3-21: Lot Criteria (Activity Center)**



**Figure 3-22: Building Placement (Activity Center)**



### 3.11.4 - Building Height

<u>↕ Overall Height (max.)</u>	<u>35 ft., except as indicated in Section 1.6.2.3 (Design Relief).</u>
<u>- Overall Height (min.)</u>	<u>22 ft.</u>
<u>- Accessory Structure Height (max.)</u>	<u>Shall not exceed height of principal structure. See Section 3.4.13 (Accessory Structures).</u>



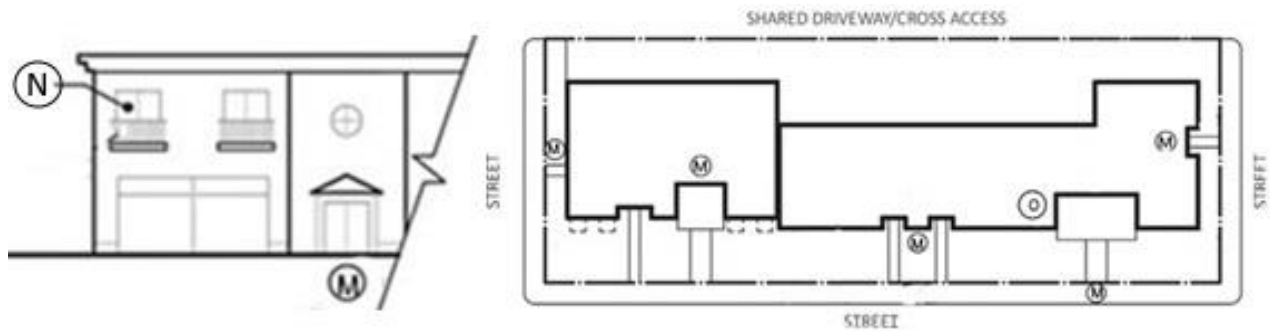
## ACTIVITY CENTER SUBDISTRICT Commercial/Office/Mixed-Use Building Types

### 3.11.5 - Building Elements – See Also, Section 3.4.4 (General), Chapter 4.0 (Architecture)

M – Location of Main Entrance on Ground Floor	<u>Faces primary street, side street, or rear or side of building.</u>
N - Transparency (min.) <sup>1,2</sup>	<u>30% - Ground floor facing primary street or corner street.</u>  <u>10% - Rear ground floor façades facing a parking lot, driveway, or common open space.</u>  <u>20% - All second floor.</u>
O - Façade Depth Variation (min.)	<u>See Chapter 4.0 (Architecture).</u>
- Façade Articulation	<u>See Chapter 4.0 (Architecture).</u>
- Encroachments	<u>See Section 3.5 (Encroachments).</u>

1. Where an architectural wall located along the rear or side of a property obscures the view of the ground floor, transparency is not required for ground floor.

**Figure 3-23: Building Elements (Activity Center)**



# 4.0 ARCHITECTURAL DESIGN STANDARDS

## 4.1 Purpose

The following architectural design standards are intended to foster the development of visually appealing buildings, enhance the pedestrian experience, and contribute to the character of the neighborhood.

## 4.2 Subdistrict Architectural Styles

In the 2017 and 2018 meetings that the City held with residents from the Becker Road vicinity, the most preferred architectural styles identified were Florida Vernacular and Mediterranean. These design standards promote the Florida Vernacular architectural style for the Becker Road Overlay District (BROD). The images illustrated in this chapter provide examples and guidance regarding the Florida Vernacular architectural style. See **Figure 4-2** and **Figure 4-3** at end of chapter.

## 4.3 Prohibited Façade Features & Materials

- large, blank, unarticulated walls that are visible from the street or to patrons or residents
- square, box-like buildings without articulation of windows or façade
- corrugated metal siding/butler buildings
- plastic siding, plastic laminates, unless indicated otherwise
- ~~unpainted concrete block walls~~ concrete block walls without stucco or other finish
- plywood (board & batten permitted)
- corrugated fiberglass
- mansard roofs
- backlit awnings

## 4.4 General Building Articulation

1. **Façade Articulation** - Building facades shall provide articulation and maintain a pedestrian scale by integrating the following architectural elements:

1. Street façades shall not exceed 20 horizontal feet without including at least one of the following elements. The sides and rear of a building facing a parking lot shall not exceed 30 horizontal feet without including at least one of the following elements:

- a. A window or door;
  - b. Awning, shutter, canopy, wall trellis, or marquee;
  - c. A wall offset (min. 1 ft.) or column, void, projecting vertical rib, pilaster with a minimum depth of four inches;
  - d. Colonnade, balcony, porch, portico, or bay window;
  - e. Complementary changes in façade materials, texture, or color.
2. Architectural treatments on the façade, such as cornices or wall bands / string courses, shall be continued around the sides of the building visible from a street.

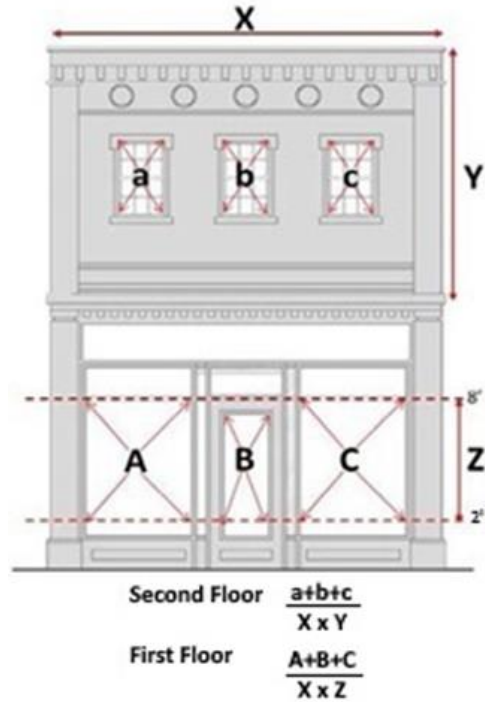
3. All building elevations (including side and rear façades) shall use similar materials and appearance as the street façade.
2. **Transparency** - Transparency is a measure of the percentage of glass associated with the windows and/or doors of a building façade. Refer to Chapter 3.0 (Subdistricts & Building Types) for transparency percentage requirements for specific subdistricts: Activity Center, Village, Professional, or Residential.
  1. Calculating Transparency - Figure 4-2 indicates how to calculate transparency for the upper and ground floors for Commercial/Office/Mixed-Use Building types.

a. For the upper floor, transparency shall be measured as follows: area of glass window/door (including sash) divided by total wall and glass window/door area of upper floor that is between the second story floor height and top of wall.

b. For the ground floor, transparency shall be measured as follows: area of glass window/door (including sash) that is between 2 and 8 feet from the finished floor divided by the total wall and glass window/door area that is between 2 and 8 feet from the finished floor.

For Townhouse and Multifamily Building Types, the lower floor transparency is calculated in a similar manner as the upper floor: area of window/door (including sash) divided by total wall and window/door area of lower floor that is between the first-floor finished floor and second story floor height.

Figure 4.1 - Transparency



2. ~~Refer to the specific subdistrict for minimum transparency area requirements. apply to a façade facing a primary street, side street, or public open space~~
2. Windows and glass doors shall be glazed in clear glass with 80 percent minimum transmittance. The use of reflective glass and reflective film is prohibited. ~~on the ground floor of all buildings.~~
3. **Windows - Commercial/Office/Institutional/Mixed-Use Building Types:** At least 80% of the window area for the overall building shall be vertical in orientation, excluding commercial storefront windows located on the ground floor which may be horizontal in orientation. Two vertical windows ~~with a mullion separating the windows~~ may be combined and included within the 80% allowance. Storefronts are encouraged to be unique in some manner to other storefronts along a street to give the streetscape more visual interest.
4. **Windows - Townhouse and Multifamily Building Types:** At least 80% of the window area shall be vertical in orientation on all sides of a building. Two vertical windows ~~with a mullion~~ may be combined and be included within the 80% allowance.

5. **Building Corners Entrances at Major Street Intersections** - Refer to Section 3.4.7 (Corner Buildings Entrances).

## 4.5 - Building Color

**Color Selection** – Refer to Citywide Design Standards, Section 9.0 and 9.1 (Building Color) and the Approved Colors Table for wall color selection. Permitted colors for roofs are indicated in BROD Section 4.6.4 (Roof Shapes, Materials, and Colors).

Exterior colors shall be light to medium pastel shades or white; earth tone colors are not permitted except for brick or stone. Refer to the Citywide Design Standards, Chapter IX, Approved Colors for color selection.

- ~~1. As per Section 1.6 (Design Relief), the Zoning Administrator may allow the use of a light to medium pastel shades of color not specified in the Citywide Design Standards and may allow a limited use of more saturated colors.~~
1. Sherwin Williams paint color numbers shall be indicated on the elevations. The applicant may use any manufacturer's paint, as long as the color matches the Sherwin Williams permitted colors listed in the Citywide Design Standards.
- ~~2. **Prohibited Wall and Colors** – All DayGlo (fluorescent) type paint colors are prohibited on any part of a building.~~
- ~~3. **Color Patterns** – Patterns or graphics such as, but not limited to, checkerboard, stripe, floral, shall be limited to 25% of a building façade, inclusive of awnings.~~

## 4.6 - Florida Vernacular Style

Florida Vernacular is an architectural style that was prevalent during the 19th century in Florida. It is a product of many distinct influences from the "Cracker", "Folk Victorian" and "Key West" styles that feature wide porches, large roof overhangs, and elevated floors. The following requirements shall be incorporated into buildings located in the Becker Road Overlay District (BROD).

### 4.6.1 - Building Materials

1. Exterior finish material on all façades shall be horizontal lapped board siding (or Hardie Board or similar), vertical board and batten siding, or smooth stucco. Stem walls or foundation piers shall be brick, stone (simulated stone), or stucco.
2. Chimneys shall be brick or stucco;
3. Railings shall be wood or have appearance of wood ~~with square or turned balustrades, or flat boards with scroll-cut pattern in a style such as in a Picket or Chippendale style.~~
- ~~4. Buildings located along the side streets~~
- ~~5. conform in style and materials to building20s located along a primary street.~~

#### 4.6.2 - Architectural Details

1. **Window Shapes** - The predominate window shape shall be vertical and rectangular. A semi-circular arch window shape (segmental arch) is permitted. A round arched window shape is not permitted. Round, square, octagonal, oval, and polygon shape windows may be used for accent for up to 5% of the ~~area of a building façade~~ area.
2. Windows with one vertical muntin in the top and/or bottom sash is preferred, or no muntins at all.
3. **Colonnades, Arcades** - The span between columns shall be flat or semi-arched (segmental arch). No round arch shape is permitted.
4. Bahama shutters that cover 100% a window are not permitted. Bahama shutters may be used as awnings that cover no more than 25% of a window opening or as architectural elements on other parts of the building.
5. Vertical board panel or louvered side-swinging shutters shall be proportional in size with the window opening.

#### 4.6.3 - Roof Shapes, Materials, and Colors

1. **Roof Types** – A gable or hip roof shall be provided on buildings that are 3,000 square feet in gross floor area or less. Buildings with flat roofs over 3,000 square feet of gross floor area shall provide peaked or pitched roof elements that extend at least 25% of the length of the sides of the building that are visible to the public. Green (organic) flat roofs may be used.
2. **Sloped Roof Pitch:** Sloped roofs shall have a gable or hip style with a roof slope that is between 4:12 to 12:12. The roof pitch for a porch, bay window, cupola, or dormer shall be a minimum of 2:12 and a maximum of 12:12. There shall be no maximum roof pitch for a steeple or spire.
3. **Sloped Roof Materials** - Roofing shall consist of one of the following: 1) Architectural grade laminated shingles 320 lb. 30-year or, 2) standing seam metal roofing, or 3) concrete/stone flat shingles, ~~or 4) wood shingles (composite polymer shingles may be considered on case-by-case basis depending on quality of imitation).~~ The use of standing seam roofs that use 5-V panels or 16-inch pattern narrow standing seam are encouraged.
4. Roof height shall not exceed the average height of the supporting walls.
5. Sloped roofs shall have eaves that overhang a minimum of 2 feet.
6. **Roof Colors Permitted** - Silver (galvalume), gray (light to dark medium), brown (medium to dark) green (light or dark, excludes bright colors), white, or cream. ~~pale taupe, beige.~~
7. ~~**Exposed Roof Equipment on Flat Roofs** - Roof mechanical equipment must be screened on all sides of a building with a parapet wall or other integrated architectural element that is part of the overall building design from a perspective that is 6 feet above grade for a distance of at least 500 feet. Individual screens for equipment are not acceptable. Equipment located on a flat roof shall not be visible from an elevation that is horizontal to the location of the roof equipment. Parapet walls are required on buildings with flat roofs to hide air conditioning units, large fans, and similar items. Smaller pipes and vents shall be painted a color that minimizes visibility.~~
8. ~~**Faux or Incomplete Hip and Gable Roof Accent Features on Buildings with Flat Roofs:** Hip roof accent features located above the top of a parapet wall and along the perimeter of a building with a flat~~

roof shall be complete in form: A hip roof shall be angled on all sides. A gable roof shall extend at least 6 feet behind the face of the building wall and at least 1 foot in front of the building wall on all sides of a building to give the building a greater sense of dimension. The façade shall incorporate vertical and horizontal articulation architectural features so that the hip or gable roof features appear integrated with the overall building design.

#### 4.6.4 Architectural Elements

Choose at least four (4) of the following elements for a façade facing a street and three (3) elements for a façade facing a parking lot. Side façades that do not face a street or parking lot shall provide façade articulation in harmony with the design of the other building faces. Different elements from the same paragraph may count as more than one architectural element, unless indicated otherwise:

1. Horizontal wood siding (or Hardie board or similar),
2. Gable End: Corbels or brackets, outriggers, decorative truss, wood shingles or simulated wood shingles (one element only),
3. Arbor, Pergola, Trellis / Decorative Screen Panels,
4. Tower, Clock Tower, Bell Tower – (min. 2:1 height to width ratio),
5. Wood style railing (Picket or Chippendale). See Section 4.6.1.3. (Materials),
6. Canopies, Awnings,
7. Exposed rafter tails,
8. Dormers and/or cupolas to break up the roofline,
9. Window and door trim at top, bottom, or all sides / window or door cornice (one element only),
10. Square columns or ~~turned columns with capital or brackets at top~~ spaced no greater than 1.5 the height of the column, Colonnade or arcade with columns spaced no greater than 1.5 the height of the column (one element only),
11. ~~Wall band, String course, recessed groove pattern or horizontal band in stucco, wall cornice with a minimum depth of 4 inches and minimum height of 16 inches at top of parapet wall, or wall cornice under roof eave~~ (one element only),
12. Complementary changes in façade materials or texture. Example, wood siding on first floor and stucco on second floor,
13. Portico, porch, bay window, marquee, chimney, or balcony,
14. Side shutters, Bahama shutters (one element only),
15. Green (vegetative) walls covering at least 25% of the building face area on the east and west wall; Green (vegetative) roof covering at least 75% of roof area,
16. Display window/s (See definitions),
17. Exterior sculpture or public art pursuant to City Code Chapter 162 (fee in lieu does not qualify),
18. Common open space plaza with customer entrance at corner of street intersection or main customer entrance/s to building facing primary street,
19. Stone, concrete, brick pavers (min. 30% of paved pedestrian areas such as sidewalks and plazas or 350 sq. ft., whichever is greater),
20. LEED Certified Building.



**Figure 4-2: Examples of Florida Vernacular Style**



*Dunedin, FL*



*Melbourne, FL*



*Palm Bay, FL*



*Palm Coast, FL*



*Port St. Lucie, FL*



*Port St. Lucie, FL*



*Panama City Beach, FL*

*Figure 4-3: Examples of Florida Vernacular Style (continued)*



*Seagrove Beach, FL*



*Key West, FL*



*Lake Buena Vista, FL*



*Celebration, FL*



*Orlando, FL*



# 5.0 LANDSCAPING

## 5.1 Purpose

The landscape regulations are designed to improve the appearance of development located along Becker Road, create shade, and increase the compatibility of adjacent uses.

## 5.2 Applicability

These landscaping provisions shall be applicable in combination with the Becker Road Overlay District (BROD) regulations and Chapter 154, the City Landscape Code. Where there is conflict, the BROD Design Standards shall supersede.

## 5.3 General

**Landscape Material:** Appropriately sized trees and other types of vegetation may be selected from the City Landscape Code Appendix C, Landscape Code Section 154.03(I) Landscaping and Utilities, the *Waterwise South Florida Landscapes* plant guide published by South Florida Water Management District, and/or the latest edition of *Plant the Right Tree in the Right Place* by Florida Power & Light (FPL).

Additional tree species may be considered based upon certification from a Florida registered landscape architect. For proposed trees not listed in Chapter 154, Landscape Code, the applicant shall provide documentation indicating the tree characteristics, applicable hardiness zone, and appropriate ecological setting for review and approval by the Zoning Administrator, (City Landscape Code Section 154.04(C)2).

**Administrative Reviews of a Landscape Plan:** Minor revisions to a Landscape Plan may be considered for approval by the Zoning Administrator as indicated in the City Landscape Code, Section 154.11.

## 5.4 ~~Building Frontage Landscape Buffers and Sidewalks~~

A continuous ~~building~~ frontage landscape buffer that abuts the Becker Road and Port St. Lucie Boulevard rights-of-way shall be provided to facilitate the creation of a pedestrian-friendly, aesthetically pleasing corridor. On side streets, a frontage landscape buffer is not required in front of parking lots and areas where there is no frontage building.

**Frontage Landscape Buffer Width:** The depth of the frontage buffer is determined by the distance of the building façade to the front property line. Where a parking lot or open space is visible from a primary street, the frontage landscape buffer depth is established by the location of the front building façade facing the street. Parking is not permitted in a frontage landscape buffer.

### 1. **Primary Street – Build-To Zone / Frontage Landscape Buffer Width**

- a) **Activity Center Subdistrict, excluding conversion areas = 35-45 feet.**
- b) **Activity Center Subdistrict, conversion areas only = 25-35 feet.**
- c) **All Other Subdistricts = 25-35 feet**

### 2. **Side Street – Build-To Zone / Frontage Landscape Buffer Width**

- a) **All Subdistricts = 25-35 feet.**

~~The frontage buffer shall be 15 feet wide for the Activity Center and for the Village, Professional, and Residential Subdistricts, and 10 feet wide for the Residential Subdistricts. For the side streets, the frontage~~

landscape buffer shall be required where a building front faces a side street. (~~Figures 5-1, 5-2, 5-3 and Sections 5.4.1, 5.4.2, and 5.4.3~~).

**Figure 5-1. Example: 45'-55' Frontage Landscape Buffer – Activity Center District on Becker Road.**



2. **Overhead Power Lines:** Overhead power lines stretch along significant portions of Becker Road and Port St. Lucie Boulevard. Smaller trees are required as compared to areas with no overhead power lines. Refer to the latest edition of *Plant the Right Tree in the Right Place* by Florida Power & Light (FPL) or to the City Landscape Code, Appendix C.

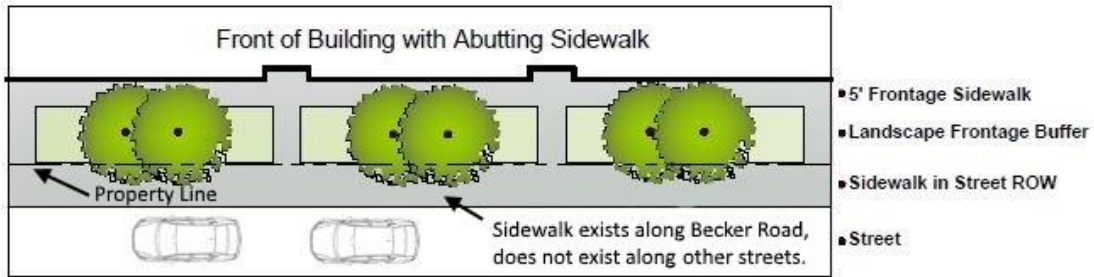
#### 5.5. 4.1 Building-Frontage Sidewalks Requirements

A continuous frontage sidewalk shall be provided along the entire length of a frontage landscape buffer and shall connect to adjacent properties, primary building entrances, common open spaces, parking lots, sidewalks located in a street rights-of way, and side street frontage sidewalks.

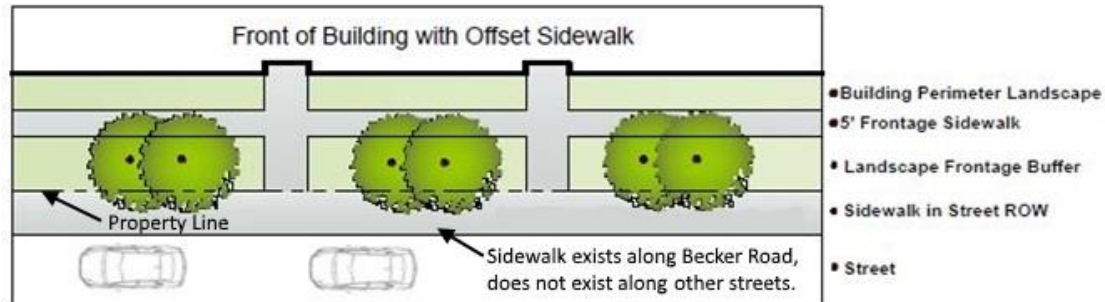
1. **Primary Streets:** The frontage sidewalk shall be at least 7-foot-wide, excluding properties located in conversion areas. Conversion areas shall have frontage sidewalks that are at least 6-foot-wide. In the Activity Center Subdistrict, excluding conversion areas, the frontage sidewalk shall have a gentle curvilinear shape and be offset from the building. Other sidewalks may be located adjacent to a building. See also Section 3.5 (Encroachments).
2. **Side Streets:** The frontage sidewalk shall be at least 5-foot-wide and may abut or be offset from the frontage building. An interconnected and continuous frontage sidewalk shall be provided in the frontage landscape buffer along side streets. For side streets located in a Residential Subdistrict, no frontage sidewalk is required where a building faces a side street provided that a 5-foot-wide sidewalk is provided within the side street right-of-way.

**Sidewalk Location:** Buildings with retail or mixed uses on the ground floor typically provide a sidewalk that abuts a building to allow pedestrians visibility into the storefront. Buildings with office, institutional, or residential uses typically provide a sidewalk that is offset from the building to allow greater privacy for individuals located inside the building.

**Figure 5-2 - Building Frontage Landscape Buffer with Abutting Sidewalk**



**Figure 5-3 - Building Frontage Landscape Buffer with Offset Sidewalk**



### 5.4.2 Frontage Buffer and Sidewalk Requirements

Subdistrict	Build-to-Zone Depth From Street Right-of-Way	Building-Frontage-Landscape-Buffer-Depth	Frontage Sidewalk-Zone <sup>1</sup> Depth	Min-Frontage-Sidewalk-Width
Activity Center / Village	22-25 ft. (all streets)	15 ft.	7 ft. - 10 ft.	5 ft.
Professional	22-25 ft. (primary street) 20-23 ft. (side streets)	15 ft. 10 ft.	7 ft. - 10 ft. 10 ft. - 13 ft.	5 ft.
Residential-Residential	25-30 ft. or 32 ft. if porch located at front (primary street) 20-30 ft. (side streets)	10 ft. 10 ft.	15 ft. - 20 ft. 10 ft. - 20 ft. Side Streets - No frontage sidewalk required	5 ft.

1. **Frontage Sidewalk Zone** is the area between the building frontage landscape buffer and the building. The frontage sidewalk shall be located within 0-2 feet of the building frontage landscape buffer.

## 5.6 Frontage Landscape Buffers – Landscaping

## 5.6.1 Building Frontage Landscape Buffers - Landscaping

<p><b>Trees</b><sup>1</sup></p>	<p>Provide at least 1 Type A tree for every 40 feet linear feet of frontage. Two 2) Type B trees may be substituted for one 1) Type A tree. Trees may be spaced no greater than 50 feet apart.</p> <p><b>Parking Lot Buffers Behind Frontage Landscape Buffer:</b> See Section 5.9 Parking Lot Landscape Buffers.</p>
<p><b>Shrubs</b> <b>All Subdistricts</b></p>	<p><u>Shrubs shall be used to create hedging and other accent landscaping. Shrubs and hedging must be continuous for at least 60% of the frontage landscape buffer width.</u></p> <p>Shrubs shall be at least 1.5 feet in height at time of planting. Grasses of similar size may be substituted for up to 30% of the shrubs. Shrub and grasses shall be maintained between 2 and 2.5 feet in height at maturity. Shrubs and grasses shall enhance the design of the building and not obscure windows or other architectural features.</p> <p><b>Activity Center, not including conversion areas:</b> Provide at least 1 shrub for each 1 linear foot of frontage landscape buffer.</p> <p><b>Conversion Areas:</b> Provide at least 1 shrub for each 1.5 linear foot of frontage landscape buffer.</p> <p><u>Saw palmetto (<i>Serenoa repens</i>) and palm species of similar appearance and maturity size are not permitted.</u></p>
<p><b>Groundcover</b></p>	<p>Provide at least 1 square foot of groundcover, excluding sod, for every 5 linear feet of <u>frontage landscape buffer area.</u></p> <p><u>Sod shall be provided for the remaining area that is not landscaped with other vegetation. Sod may be utilized for up to 50% of the square-footage of groundcover required.</u></p>
<p><b><del>Raised Planter Area</del></b> <b><del>Border Wall, Fence,</del></b> <b><del>Edging</del></b></p>	<p>The frontage landscape buffer area may include a <u>low-border-wall for-a raised planter bed, fence, or edging</u> that is up to 18 inches in height. <u>If seating is located on top of the wall, the seating may not encroach into the minimum frontage sidewalk width.</u></p>

1. Type A (large) and Type B (small) trees refers to trees identified in the City Landscape Code, Appendix C.

## 5.7 Perimeter Building Landscape Buffers - Front, Sides, and Rear

A perimeter building landscape buffer shall be located around all sides of a building that are visible to the general public, patrons, or residents, unless indicated otherwise below. Landscaping shall be designed to be complementary to the design of the building. See Section 5.3 (Building Frontage Landscape Buffers).

<b>5.7.1 Perimeter Building Landscape Buffers - Front, Sides, and Rear</b>	
<b>Buffer Depth</b>	<u>A perimeter building landscape buffer shall extend between 3 and 15 feet from a building on all sides. Sidewalks may be located within a perimeter building landscape buffer.</u>
<b>Trees</b> <b>Hedges &amp; Shrubs</b> <b>Groundcover</b>	<p><b>Trees:</b> Provide one Type B tree or other similar small type tree appropriate to the depth of the buffer for every 30 linear foot of building wall. Trees shall be at least 8 ft. in height at time of planting.</p> <p><b>Trees Not Required:</b></p> <ul style="list-style-type: none"> <li>• Building façades where ground floor transparency is 50% or more. A tree is required where a building wall has no windows for at least 30 feet.</li> <li>• Building façades that have an arcade or colonnade.</li> </ul> <p><b>Shrubs:</b> Provide at least 1 shrub for every 2 feet of building perimeter that is at least 2 feet (min.) in height at time of planting, <u>excluding width of doors and windows that are less than 2 feet from grade. Shrubs located adjacent to a building shall not obscure windows.</u></p> <p>Groundcover, excluding sod, shall be provided <u>at 1 sq. ft. for every 2 linear foot of building perimeter.</u></p>

## 5.8 Site Perimeter Landscape Buffers

Unless indicated otherwise in this document, refer to the City Landscape Code Section 154.03 (C)1 for site perimeter landscape buffer requirements.

<b>5.8.1 Site Perimeter Landscape Buffers</b>	
<b>General Exceptions</b>	<p>A site perimeter landscape buffer is not required where a frontage landscape buffer is located along a primary or side street.</p>
<b>Abutting Parking Lots</b>	<p>Parcels shall not be required to install a perimeter site buffer along the side or rear of a lot if the side or rear of the parking lot abuts to or connects with an existing or potential future parking lot. A perimeter building landscape buffer is required. See Section 5.7.</p>
<b>Abutting Driveways</b>	<p>Along entrance driveways, where a front of a building faces a driveway located along a side property line, a site perimeter landscape buffer along the entrance driveway shall not be required.</p>
<b>Buffer With Architectural Wall</b>	<p><b>Properties Adjacent to or Abutting RL (Low Density Residential) and Open Space Land Uses:</b> Refer to Section 154.03(C)5 of the City Landscape Code for architectural wall and landscape requirements.</p>

## 5.9 Parking Lot Landscape Buffers

Unless indicated otherwise in this document, refer to the City Landscape Code Section 154.03 (C)3 for parking lot landscape buffer requirements. Where fueling station canopies, parking lots, stormwater storage areas are located adjacent to a frontage landscape buffer, landscaping shall be used to minimize the visibility of these areas.



## 5.9.1 Parking Lot Landscape Buffers Along Frontage Landscape Buffers

<p><b>Primary Streets</b></p> <p><b>Parking Lots and Other Areas with No Building Frontage Facing Primary Streets</b></p>	<p>Where a fueling station, parking lot, stormwater area, driveway, or other area where there is no building that fronts along a frontage landscape buffer is located, a minimum 10' wide parking lot landscape buffer shall be provided. This semi-opaque buffer is intended to screen or minimize the view of uses such as fueling station canopies, drive-throughs, and parking lots.</p> <p><b>Location:</b> The front face of the 10' wide parking lot landscape buffer that abuts a frontage landscape buffer shall be aligned with the front face of the building on site or may encroach up to 10 feet into the frontage landscape buffer.</p> <p>This landscape buffer may be used to satisfy parking lot landscape buffer requirements provided the parking lot is located within 30 feet of this landscape buffer (or 20' between buffers).</p> <p><b>Trees:</b> Provide at least one smaller Type B tree for every 20 linear feet. At maturity, Type B trees shall be between 15-25 feet in height. The bottom of canopy shall be no greater than 8 feet in height from grade at maturity. Palm trees are not permitted.</p> <p><b>Hedge:</b> Provide a hedge that is at least 3-feet in height at time of planting. The hedge shall be maintained at a height between 3.5 to 4 feet in height.</p> <p><b>Substitution:</b> A 4-foot-high wall or fence that is at least 70% opaque may be substituted for the hedge.</p> <p><b>Shrubs:</b> Smaller shrubs shall be located in front of the hedge, fence, or wall facing the primary street. Along a hedge, at least one shrub shall be provided for each 4 linear feet of frontage. Along a wall or fence, at least one shrub shall be provided for each 2 linear feet of frontage. Shrubs shall be at least 2 feet in height at time of planting.</p> <p><b>Groundcover:</b> Provide at least 1 sq. ft. of groundcover for every 2 linear feet of parking lot landscape buffer located adjacent to the frontage landscape buffer.</p>
<p><b>Side Streets</b></p>	<p>Where a parking lot abuts a side street, landscaping is required for the 10-foot-wide parking lot landscape buffer as follows:</p> <p><b>Hedge:</b> A hedge located adjacent to the parking lot shall be provided and maintained at a height between 3-4 feet to screen the view of cars in the parking lot.</p> <p><b>Shrubs:</b> Additional shrubs shall be planted in front of the hedge. These shrubs may be planted in non-continuous planting beds, and they shall be lower in height than the hedge located adjacent to vehicles. Provide at least 1 shrub for every 2 linear feet of the parking lot length, excluding access areas. Shrubs shall be at least 1.5-feet in height at time of planting and maintained at a height between 2-3 feet.</p> <p><b>Groundcover:</b> Provide at least 1 sq. ft. of groundcover for every linear foot of parking lot landscape buffer located adjacent to a side street.</p>

## 5.10 Detention / Retention Stormwater Pond Landscaping

In addition to providing storage for water runoff, stormwater ponds shall be designed to be scenic amenities to a site. Trees shall be provided within 0-20 feet of the top of bank of a detention / retention area if there are no trees provided within 30 feet of the top of bank with approval of Public Works Department. One Type A tree or two Type B trees shall be provided for every 50 linear feet of the top of bank distance. Trees may be clustered or spaced at irregular intervals. At least one shrub shall be provided for every 8 linear feet of the stormwater top of bank perimeter. Shrubs shall be at least 2 feet in height at time of planting. At least 1 sq. ft. of groundcover, excluding sod, shall be provided for every 8 linear feet of the top of bank perimeter. At least one bench shall be provided around a stormwater pond for each 400 linear feet of top of bank perimeter.

# 6.0 COMMON OPEN SPACE

## Purpose

Provide common open space that offers a place for people to gather and enhances the attractiveness of the Becker Road Overlay District (BROD). ~~These requirements apply to all subdivisions in the BROD.~~ Refer also to Section 3.5 (Encroachments).

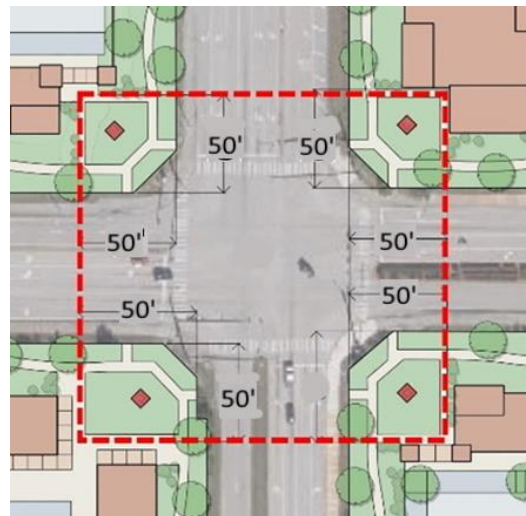
### 6.1 Corner Common Open Spaces at Major Intersections

1. Properties located at the intersections of Becker Road and Port. St Lucie Boulevard, Becker Road and Savona Boulevard, and Becker Road and Darwin Boulevard shall provide a common open space plaza at the corners of buildings facing the corner intersections.
2. Paving or sidewalks shall extend to the street right-of-way or to the street curb within the street right-of-way with approval of the Public Works Department in order to provide pedestrian connectivity. At least 30% of the paved pedestrian area shall include brick or concrete pavers. Stamped concrete is not permitted. Corner plazas may encroach into the frontage landscape buffer as indicated in Section 3.5 (Encroachments).

### 6.2 Becker Road and Port St. Lucie Blvd. Corner Intersection

Each of the four corners at Becker Road and Port St. Lucie Boulevard shall designate a common open space as described herein. The minimum dimensions for the open spaces are shown on Figure 6.1 below. Corner plazas or common open spaces shall be at least 50' x 50' measured from the street ROW. The location of the corner spaces is determined by the overlay of a square shape over all four corners to create an open space that has a unified design. Public Art shall be located at the corner common open space. Or, pursuant to the Chapter 162 (Art in Public Places), a fee in lieu may be paid. If a fee in lieu of Public Art is provided, the corner open space shall include a landscape amenity such as water feature, fountain, statuary, sculpture, or raised planter bed along with landscaping, hardscaping, and lighting. A landscape amenity does not replace the Public Art requirement.

**Figure 6.1 Corner Open Space Dimensions and Shape Diagram**



### 6.3 Darwin, Savona and Becker Road Corner Intersections

1. **Becker Road and Darwin Blvd. / Becker Road and Savona Blvd. –** Properties located at the intersections of Becker Road, Savona Boulevard, and Darwin Boulevard shall provide at least 1% (.01) of the total site area for common open space. Corner open space plazas are encouraged.
2. Common open space shall be defined by the use of amenities such as benches, public art, fountains, water features, gazebos, pergolas, and/or picnic tables, inclusive of landscaping. Other accessory features may include drinking fountains, decorative lighting, and garden statuary. Landscape amenity does not replace the Public Art requirement.

~~Each site shall provide a percentage of the total site area as common open space in the form of plazas, terraces, greens, patios, decks, or squares that are integral to the overall design of the site.~~

- ~~3. Properties located at the intersections of Becker Road and Port. St Lucie Boulevard, Savona Boulevard, and Darwin Boulevard shall provide at least 1% (.01) of the total site area for common open space. Other properties shall provide at least .5% (.005) of the total site area for common open space.~~
- ~~1. Common open space shall be defined by the use of pedestrian amenities such as public art, fountains, water features, benches, gazebos, and pergolas, and/or picnic tables, inclusive of landscaping. Other accessory features may include drinking fountains, decorative lighting, garden statuary and accents, and garbage receptacles.~~
- ~~2. The common open space shall may serve as way to celebrate a gateway area or function as a place for recreation or leisure time enjoyment and shall include landscaping such as trees, shrubs, and pedestrian amenities in addition to paved areas.~~
- ~~3. The required common open space may be divided into smaller spaces that are at least 100 sq. ft. in size at the front, back, or sides of buildings or site.~~
- ~~4. **Primary Street Frontage Plazas** – The decorative Paving shall extend to the street curb or edge of street right of way, within the street ROW, with approval of the Public Works Department. A corner plaza located at a street intersection or a plaza located at the front of a building are typically preferable locations for common open space. At least 50% of the paved area shall include decorative pavers or material other than a concrete slab. Stamped concrete is not permitted. Access along the frontage sidewalk shall not be obstructed. See Section 3.5 (Encroachments) for allowed common open space encroachments into the build to zone or frontage sidewalk buffer.~~
- ~~a. **Building Front Plaza** – Common open space for a plaza located in front of a building may include the frontage sidewalk buffer area provided the entire area has a unified paving and landscaping design.~~

~~**Corner Plaza** – The area within a building frontage landscape buffer sidewalk zone and the building frontage landscape buffer may be counted toward meeting the common open space requirement for a corner plaza located along a primary street. The decorative paving shall extend to the street curb within the street ROW, with approval of the Public Works Department~~

# 7.0 PARKING & ACCESSIBILITY

## 7.1 Purpose

This section establishes the requirements for parking, sidewalks, and bicycles in the Becker Road Overlay District (BROD) to ensure that adequate accessibility is provided to safely and conveniently accommodate anticipated needs while being compatible with adjacent development.

## 7.2 Applicability

Off-street automobile parking and loading shall be provided for all new development in accordance with the City Zoning Code, Section 158.221 and the requirements of this section. Refer to the City Land Use Conversion Manual for distance requirements for curb-cuts.

## 7.3 Parking Location

All on-street parking spaces and loading areas shall be located to the back of buildings located along a primary street and to the back or side of buildings located along a side street, except as otherwise indicated in Sections 7.3.1 and 7.3.2 below.

### 7.3.1 Parking Location for Properties Less Than 150 Feet Deep

Properties that are less than 150 feet deep may locate off-street parking to the side or rear of a building that fronts a primary street. See Section 4.3.4 (General).

### 7.3.2 Activity Center District - Parking and Driveway Location for Buildings with Drive-throughs and Gas Stations ~~and Driveway Access from Street~~

1. **Convenience Stores / Fueling Stations** - Driveways, parking, and fueling pumps shall be located to the side or rear of a convenience store or other associated building. See Sections 3.4.7.1 (Activity Center).
2. **Drive-throughs** - Driveways and parking shall be located to the side or rear of buildings with drive-throughs. For location of stacking lanes, see Section 3.4.7.2. Angled or parallel parking may be located along the entrance area of the driveway access area located to the side of a building facing a street provided approval is obtained from Public Works. Refer to City Land Use Conversion Manual and Zoning Code Section 158.222(B) for minimum curb-cut distances along streets from intersections and driveways.

***Figure 7-1. Example: Quick-service restaurant with stacking lane behind building.***



### 7.3.3 On-street Parking on Side Streets

On-street parking may be placed on the side streets provided that the right-of-way is not needed for turning lanes or other improvements and the on-street parking is approved by the Public Works Department. On-street parking spaces may be counted toward the number of required parking spaces for site plan approval. Where possible, on-street parking is encouraged in areas where a building fronts along a side street as a way to provide easy access to the front entrance of a business, office, or residence.

### 7.3.4. Vehicular Parking Located Under Second Floor for Office Building

**Figure 7-2. Example of Parking Under Second Floor Office Building**



In areas designated with Professional (P) zoning, up to 40% of the total length of the first floor of the building may be used for parking. This is to encourage the development of office buildings that are two floors in height. The following conditions apply:

1. The building/s shall consist of at least 2 floors and the second floor shall extend at least 100% of the length of total first floor length,



2. The parking area under the second floor shall be enclosed with walls that are constructed with the same material and finish as the enclosed office area so that the façade for the parking area looks similar to the façade for the office area. Window openings for the enclosed parking area shall be similar in size, shape, and placement to those for the office use area. Decorative grates or screens in the window openings for the parking area shall be complementary in style with the windows of the office building.

#### 7.4 Amount of Off-Street Parking

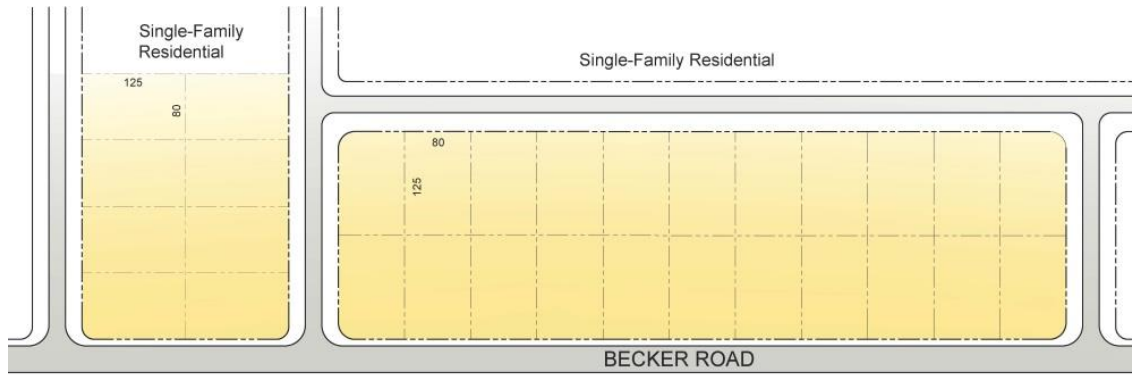
Refer to the City Zoning Code Section 128.221(C) for Off-Street Parking requirements, except as specified otherwise below:

1. Restaurants, freestanding and outparcels - One space per 100 square feet of gross floor area.
2. Convenience Stores with Fueling Stations - One space for each 250 square feet of gross floor area.
3. Fueling Stations - One parking space on each side of a fueling pump shall be counted toward meeting parking requirements for an associated convenience store or similar use located within 80 feet of the fueling station.
4. Shopping Center - One space for each 300 square feet of gross floor area for buildings 30,000 square feet and greater.
5. Office (administrative, business, medical, or professional, retail shops, personal service establishments, household repair or equipment shops) - One space for each 275 square feet of gross floor area for buildings 30,000 square feet and greater.

#### 7.5 Block Configuration and Cross-Blocks: Vehicular and Pedestrian Access

The Becker Road corridor is lined by two different block configurations: the short end of a block (“Short End Block”) and the long side of a block (“Long Side Block”). The Short End Block has two lots that front along Becker Road and the short end block is typically 250 feet in width. The Long Side Block has multiple lots that front along Becker Road and the side block is typically between 500 - 1,200 feet in length (**Figure 7-2**).

**Figure 7-3: Short End and Long Side Blocks**



**Short End Block**

**Long Side Block**

~~**Parcel Assimilation:** Prior to requesting approval for development located on lots zoned single-family residential (RS-2), a minimum number of lots must be assembled and rezoned as indicated in the City Land Use Conversion Manual.~~

1. ~~**Blocks Pedestrian and Vehicular Access**~~ - Refer to the City Land Use Conversion Manual and City Zoning Code Section 158.222(B) for minimum curb-cut distances along streets from intersections and driveways, except where otherwise restricted by the Becker Road Overlay District (BROD) Design Standards. See 7.5.1.4 below.
  1. **Pedestrian Access** - Development shall provide an inter-connected pedestrian circulation system that links building entrances to sidewalks located within a street right-of-way, sidewalks located within a frontage landscape buffer, adjacent parcels, and parking lots.
  2. **Vehicular Access - Short-End Blocks and Cross Access**
    - a. The Short-End Block is too narrow to allow direct vehicular access from Becker Road. No curb cuts are permitted on the short end of a block. Access to a site shall occur from the side streets.
    - b. ~~A driveway from each of the side streets is required that connects the two streets associated with the block.~~
  3. **Vehicular Access - Long-Side Blocks and Cross Access**
    - a. The developer shall grant cross-access to each abutting property for vehicular and pedestrian ingress and egress. Stub-outs for vehicular and pedestrian accessways shall extend to the property line so that any future connection may be easily completed.
  4. **Activity Center District:** See Section 2.3.3.1 (Special Exception Uses) for access from local side streets to properties located within the Activity Center District.
    - b. ~~When the adjacent property is under development review, the owner of the adjacent property will be required to reciprocate with a similar cross-access easement and complete the physical connection.~~

~~*7.6 Planned Unit Development (PUD) Zoning District Parking Adjustments*~~

~~Off-street parking and off-street loading facilities shall be provided as set forth within Section~~

~~158.221 of the City Zoning Code and Chapter 7.0 of the BROD, unless otherwise set forth within a PUD document. Proposed modifications to the parking requirements of the City Zoning Code Section 158.221 or the BROD Chapter 7.0 shall be accompanied with an analysis justifying such modifications. Compact parking spaces shall not be permitted by right for a PUD as indicated in Section 158.174(G) of the City Zoning Code.~~

## 7.6 Bicycle Parking

**Purpose** - Provide safe and convenient areas for the circulation and parking of bicycles that encourage the use of this alternative mode of transportation.

<b>7.6.1 - Number of Bicycle Parking Spaces</b>	
<b>Non-residential Uses (min.)</b> <u>Excludes Industrial and Auto-Oriented uses such as car washes and fueling stations.</u>	1 bicycle parking space for every <del>20</del> 25 vehicular parking spaces is required.
<b>Residential Uses (min.)</b>	1 bicycle parking space for every 6 residential units is required.
<b>7.6.2 - Location and Design of Bicycle Parking Spaces</b>	
Bicycle parking areas shall be well-lighted, secure, and within a convenient distance of an entrance.	
<b>Non-Residential Uses (min.)</b>	Bicycle parking spaces shall be located within <u>75</u> feet from the front and/or rear entrances. Bicycle parking shall be located in areas that do not detract from the appearance or use of the front entrance.
<b>Residential Uses (min.)</b>	Provide bicycle racks within <u>75</u> feet from the front and/or rear entrances of residential units and in semi-public areas such as a clubhouse, office, or mail kiosk.

**Figure 7-4: Custom Designed Bicycle Racks**



(Source: CycleSafe, Inc.)



(Source: Anova)