



TRADITION

SOUTHERN GROVE 4

Master Planned Unit Development MPUD
Amendment #2

APPLICATION FOR MPUD
OF SOUTHERN GROVE
(Parcel SG-4)

City Project Number: ~~P20-111~~ P22-227
Ordinance 22 -
PSLUSD Project No: 11-900-00

Prepared for:

Mattamy Palm Beach, LLC
1500 Gateway Blvd, Suite 212
Boynton Beach, FL 33426

and

CCC-PSL LLC
431 Office Park Dr., 2nd Floor
Birmingham, AL 35223

Prepared by:

Lucido & Associates
701 SE Ocean Boulevard
Stuart, FL 34994

September 11, 2020
Amendment #1: July 6, 2022
Amendment #2: December 14, 2022

LIST OF AMENDMENTS (Amendment #2)

- Adjust MPUD parcel boundaries to add approximately 31.78 ac of land to the development area and adjust all maps and exhibits accordingly
- Include documentation to reflect ownership entities of Mattamy Palm Beach, LLC and CCC-PSL, LLC
- Provide sketch and legal descriptions for additional land area
- Refine terminology to include 'multi-family horizontal' and 'multi-family vertically attached' development programs
- Refinement of miscellaneous development criteria language as directed by the City
- Revise/add language regarding perimeter landscape buffer strips and wall requirements
- Revise conceptual land use plan to eliminate access arrows along Community Blvd

TABLE OF CONTENTS

List of Exhibits.....	4
Project Team.....	5
Introduction.....	6
Location Map.....	7/8
Aerial Map.....	9/10
Land Use and Zoning Map.....	11/12
Exhibits.....	13-57

LIST OF EXHIBITS

Exhibit 1: PUD Amendment Application.....	13
Exhibit 2: MPUD Application Checklist.....	14
Exhibit 3: Statement of Unified Control.....	15
Exhibit 4: Standards for District Establishment.....	17
Exhibit 5: Site Information.....	18
Exhibit 6: Development Uses and Standards.....	19-25
Exhibit 7: Sketch and Legal Description.....	26-44
Exhibit 8 Conceptual Plan.....	35/46
Exhibit 9: Development Program.....	47
Exhibit 10 A-J: Typical Lot Layout.....	48-52
Exhibit 11: Typical Roadway Sections.....	53
Exhibit 12: Binding PUD Agreement.....	54/55
<u>Exhibit 13: Authorization Form.....</u>	<u>56/57</u>

PROJECT TEAM

PROPERTY OWNER/APPLICANT

Mattamy Palm Beach, LLC
1500 Gateway Blvd, Suite 212
Boynton Beach, FL 33426

and

CCC-PSL LLC
431 Office Park Dr., 2nd Floor
Birmingham, AL 35223

AGENT/LAND PLANNER

Lucido & Associates
701 SE Ocean Blvd
Stuart, FL 34994

ENGINEER

Kimley-Horn
445 24th St, Suite 200
Vero Beach, FL 32960

TRAFFIC CONSULTANT

MacKenzie Engineering and Planning, Inc.
10795 SW Civic Ln
Port St. Lucie, FL 34987

SURVEYOR

Caulfield & Wheeler, Inc.
410 SE Port St. Lucie Blvd
Port St. Lucie, FL 34984

INTRODUCTION

The Southern Grove 4 (SG-4) proposed development area of approximately 344 376 acres. The property currently has existing land use of New Community District-NCD and is zoned St. Lucie County AG-5. The proposed development area is located within the Southern Grove DRI of the City of Port St. Lucie, just west of Interstate 95 and south of Paar Drive (E/W #4).

The intent of this MPUD is to create residential development consistent with the City's Comprehensive Plan Policy 1.2.2.3 Residential Area. Open Space areas shall complement the development with natural zones and include corridors to incorporate the Tradition Trail network.

This is the second amendment to the existing SG-4 MPUD.

LOCATION MAP (existing)

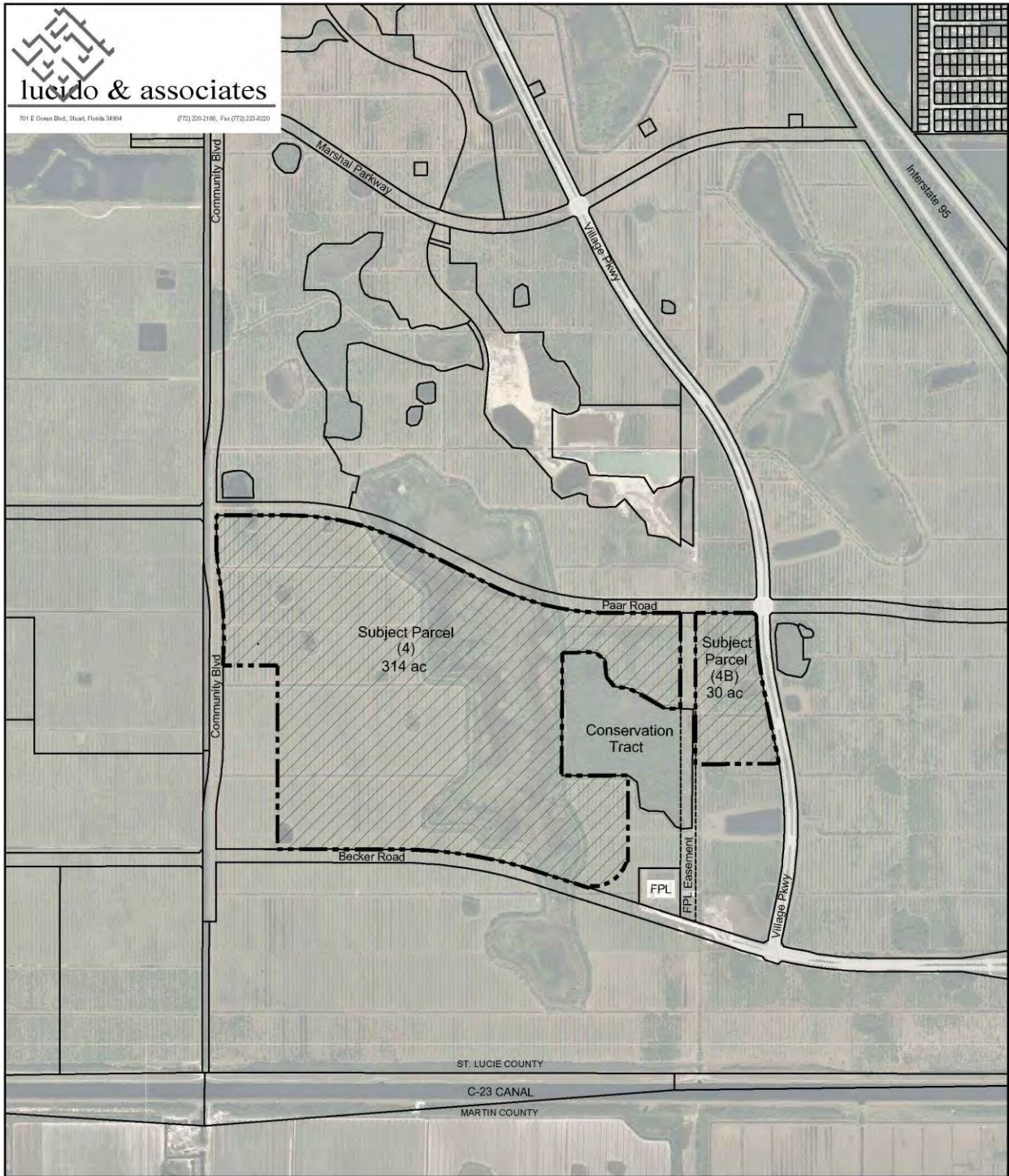

lucido & associates
701 E Ocean Blvd, Stuart, Florida 34984 (772) 220-2100, Fax (772) 220-4220

Computer File
Project Number 20-370
Scale: 1" = NTS



SG3-Location Map

Port St. Lucie, Florida

LOCATION MAP (proposed)

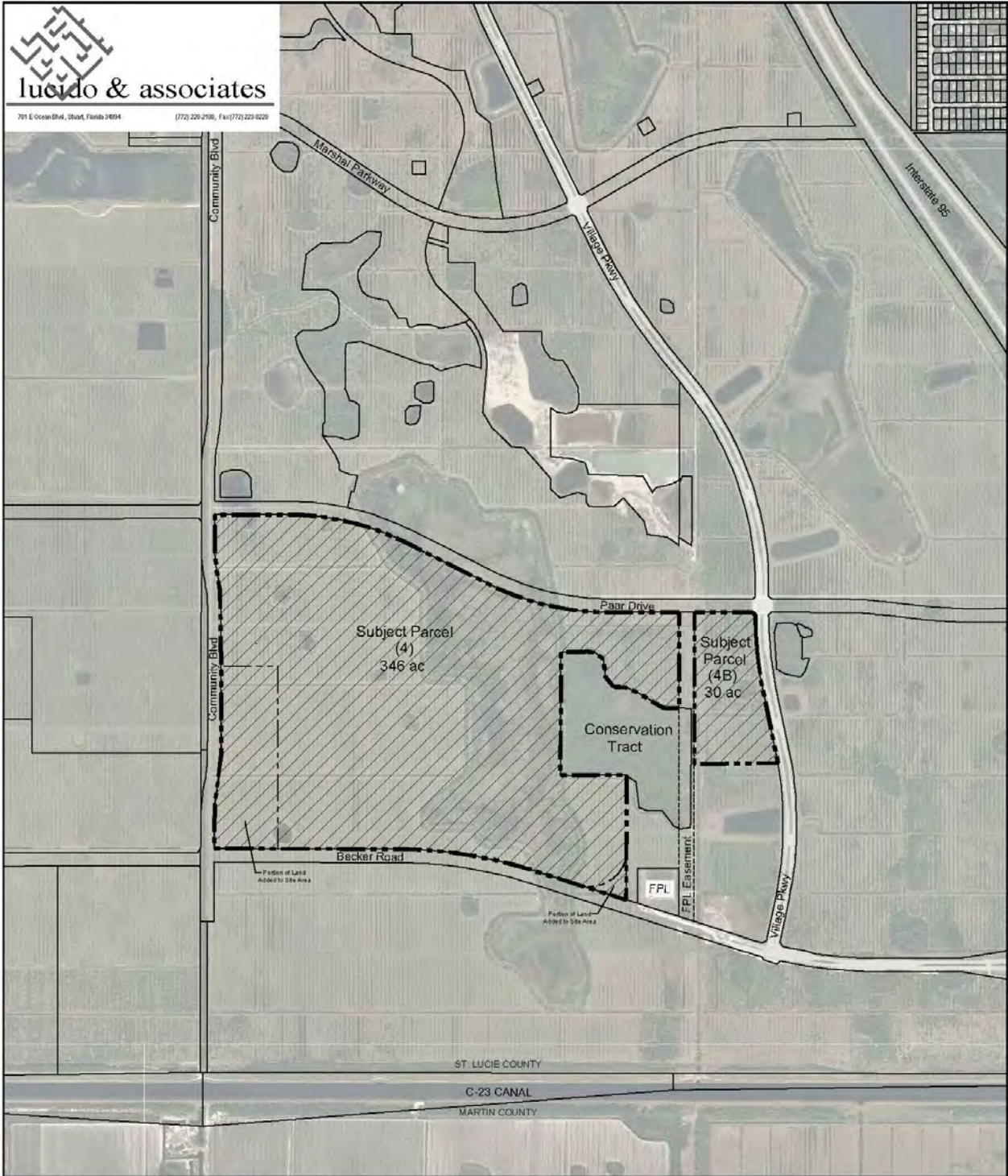

Computer File P20-111 Zoning and land use exhibits - MPUD.dwg
Project Number 20-370
Scale: 1" = NTS



Location Map

Port St. Lucie, Florida

AERIAL MAP (existing)



Computer File
Project Number 20-370
Scale: 1" = NTS



SG3-Aerial Map

Port St. Lucie, Florida

AERIAL MAP (proposed)



lucido & associates
701 E Ocean Blvd., Stuart, Florida 34984 (772) 226-2100, Fax (772) 223-6220

Computer File P20-111 Zoning and land use exhibits - MPUD.dwg
Project Number 20-370
Scale: 1" = NTS



Aerial Map

Port St. Lucie, Florida

LAND USE and ZONING MAP (existing)

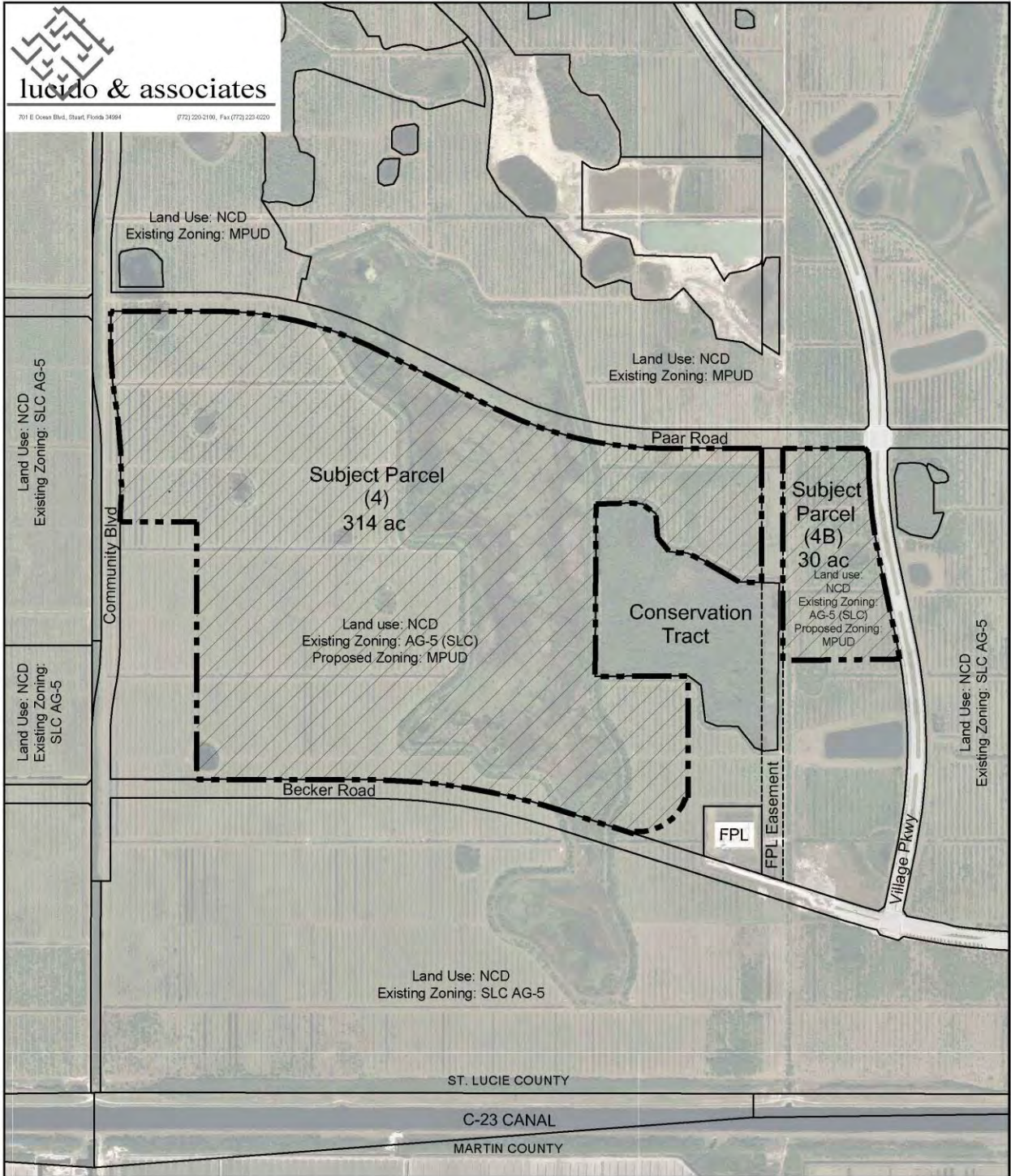

Computer File
Project Number 20-370
Scale: 1" = NTS

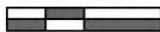

Land Use and Zoning Plan

Port St. Lucie, Florida

LAND USE and ZONING MAP (proposed)

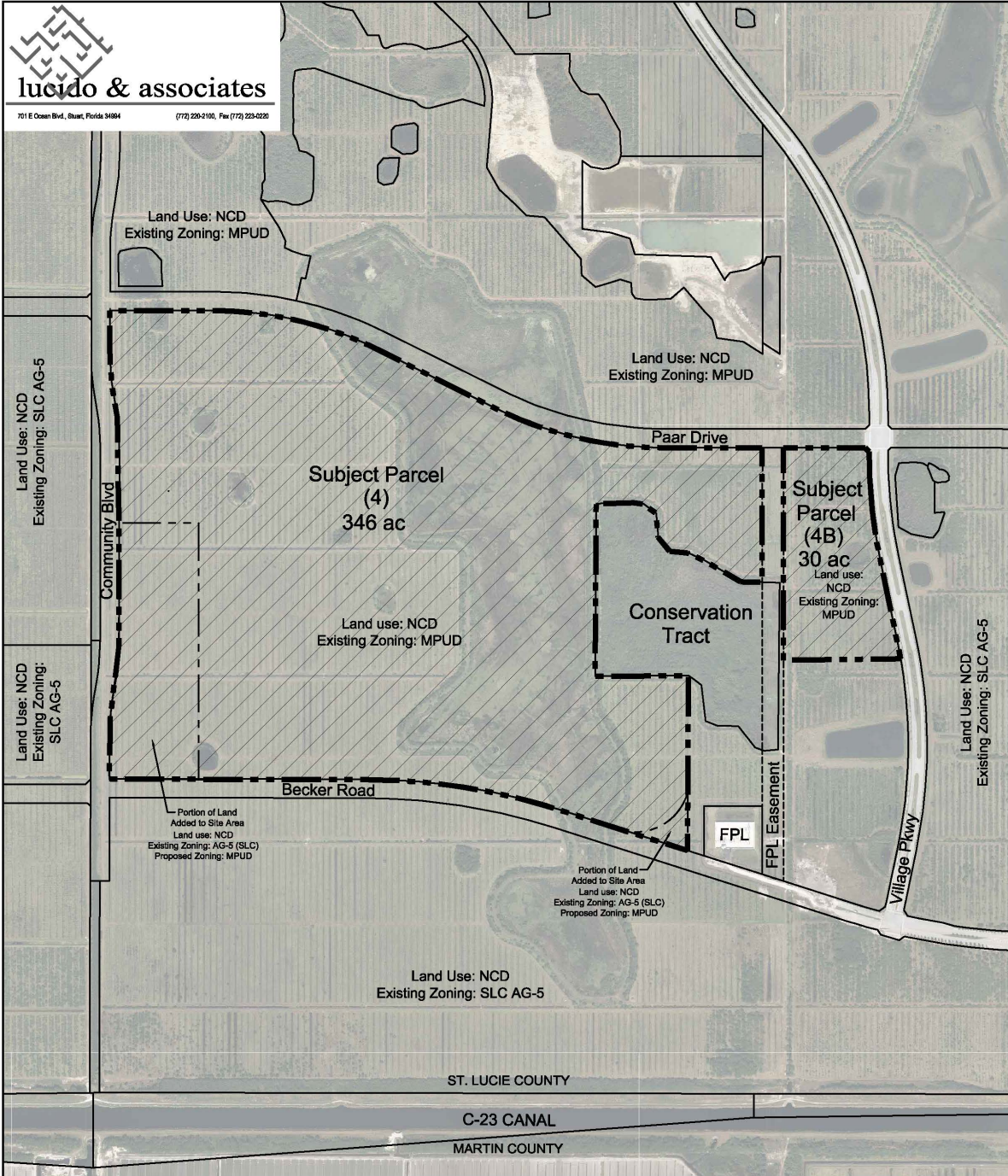

Computer File P20-111 Zoning and land use exhibits - MPUD.dwg
Project Number 20-370
Scale: 1" = NTS



Land Use and Zoning Plan

Port St. Lucie, Florida

EXHIBIT 1

PUD AMENDMENT & REZONING APPLICATION

City of Port St. Lucie

Planning & Zoning Department
121 SW Port St. Lucie Boulevard
Port St. Lucie, FL 34984
(772) 871-5212 FAX (772) 871-5124

FOR OFFICE USE ONLY

Planning Dept. P20-111 P22-227
Date Received _____
Fee & Receipt # _____

Refer to "Fee Schedule" for application fee. Make checks payable to the "City of Port St. Lucie". Fee is nonrefundable. All items on this application should be addressed, otherwise it cannot be processed. Attach proof of ownership i.e., two copies of deed or contract for purchase. Please type or print clearly in **BLACK** ink.

PROPERTY OWNER:

Name: Mattamy Palm Beach, LLC, by Tony Palumbo, VP of Land Acquisitions & Development, SE Florida Division
Address: 2500 Quantum Lakes Drive, Suite 215, Boynton Beach, Florida 33426
Telephone No.: (772) 340-3500 FAX No.: _____
And: CCC-PSL LLC, 431 Office Park Dr., 2nd Floor, Birmingham, AL 35223

AGENT OF OWNER (if any):

Name: Lucido & Associates, by Steven D. Garrett,
Address: 701 SE Ocean Blvd., Stuart, FL 34994
Telephone No.: 772-220-2100 FAX No.: 772-223-0220

PROPERTY INFORMATION

Legal Description: See Exhibit 7
Parcel I.D. No.: See Exhibit 7
Current Zoning: St. Lucie County AG-5
Proposed Zoning: MPUD
Future Land Use Designation: NCD Acreage of Property: 344 376 ac +/-
Reason for rezoning request: To create a new MPUD within the Residential Area of the NCD Land Use within Southern Grove DRI

- 1) Applicant must list on the first page of the attached amendment all proposed changes with corresponding page number(s).
- 2) All proposed additions must be underlined and deleted text must have a strikethrough.
- 3) Where there are conflicts between the requirements of the general provisions of this chapter or other applicable codes of the city and the requirements established by official action upon a specific PUD, the latter requirements shall govern.

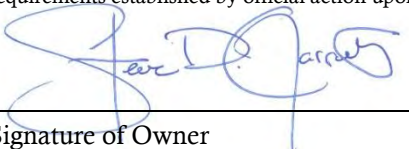

Signature of Owner

06/17/20

Date

*If signature is not that of the owner, a letter of authorization from the owner is needed.

NOTE: Signature on this application acknowledges that a certificate of concurrency for adequate public facilities as needed to service this project has not yet been determined. Adequacy of public facilities is not guaranteed at this stage in the development review process. Adequacy for public facilities is determined through certification of concurrency and the issuance of final local development orders as may be necessary for this project to be determined based on the application material submitted. **Procedure** Section158.175(B)

EXHIBIT 2

MPUD APPLICATION CHECKLIST

1. Statement of Unified Control of the entire area within the proposed PUD is enclosed as Exhibit 3.
2. Southern Grove 4 MPUD is a proposed community designed to encompass single family residential, multi-family residential, paired villa/duplex residential, and open space opportunities.
3. The Conceptual Plan for Southern Grove 4 MPUD is enclosed as Exhibit 8.
4. See Exhibit 4 for General Standards established for this MPUD. Development uses and standards are enclosed in Exhibit 6.
5. Includes the rezoning of approximately ~~344~~ 376 acres located west of I-95. The site is bordered by Paar Drive to the north, Community Blvd to the west, and Village Parkway to the east and Becker Road to the south.

EXHIBIT 3

JUNE 15, 2020

Planning & Zoning Dept.
City of Port St. Lucie
121 SW Port St. Lucie Blvd
Port St. Lucie, FL 34984

Re: SOUTHERN GROVE 4 (PARCEL SG-4) MPUD

This letter is provided as a Statement of Unified Control in compliance with the City of Port St. Lucie zoning requirements. MATTAMY PALM BEACH, LLC is the owner of record of the subject property and copies of the warranty deeds are attached to this application.

Please feel free to contact me if you have any additional questions or comments.

Sincerely,



Tony Palumbo
Director of Land Acquisitions & Development
Mattamy Homes

December 6th, 2022

Planning & Zoning Dept.
City of Port St. Lucie
121 SW Port St. Lucie Blvd
Port St. Lucie, FL 34984

Re: SOUTHERN GROVE 4 (PARCEL SG-4) MPUD

This letter is provided as a Statement of Unified Control in compliance with the City of Port St. Lucie zoning requirements, CCC – PSL LLC is the owner of record of a portion of the subject property, which portion is further described below, and copies of the warranty deeds are attached to this application.

Sincerely,

CCC-PSL LLC

By: 

Name: Ben Walker

Its: Authorized Person

The land referred to herein below is situated in the County of St. Lucie, State of Florida, and described as follows:

Parcel 1:

Tract B, of Southern Grove Parcel 28 Replat, according to the plat thereof, as recorded in Plat Book 95, Page 27, of the Public Records of St. Lucie County, Florida.

Parcel 2:

Non-Exclusive Easement for Storm Water Drainage for the Benefit of Parcel 1, as described in that Certain Drainage Easement recorded June 28, 2018 in Official Records Book 4150, Page 2743, of the Public Records of St. Lucie County, Florida.

EXHIBIT 4

GENERAL STANDARDS FOR DISTRICT ESTABLISHMENT

General Information: Current agricultural operations and exemptions on the property may continue.

Pursuant to Goals, Objective, and Policies of the City's Comprehensive Plan:

Area Requirements: The Southern Grove 4 MPUD property is approximately ~~344~~ 376 acres. The proposed development is consistent with Objective 1.2.2.3 in creating a New Community Development District to facilitate the development of a residential area.

Relation to Major Transportation Facilities: The Southern Grove 4 MPUD property is located south of Paar Drive (northern limits), west of Village Parkway (eastern limits), east of Community Boulevard (western limits) and north of Becker Road (southern limits). Main access to the property will be along both Paar Drive and Becker Road. Potential access points along Community Blvd may be considered once that roadway is constructed by others. Conceptual access points illustrated in Exhibit 8 may be refined, adjusted, and augmented during the site plan approval process for each parcel in coordination with the Public Works Dept. The proposed development is arranged in a manner to provide access to the property without creating or generating traffic along minor streets within residential areas or districts outside the MPUD.

Relation to Utilities, Public Facilities and services: The Southern Grove 4 MPUD property will be served by Port St. Lucie Utility Systems Department for water and wastewater, Home Town Communications for phone and cable service, Florida Power & Light for electricity, and Tradition Irrigation Company for irrigation quality water. All Utilities will be underground.

Physical Character of the Site: The Southern Grove 4 MPUD property is located within the Southern Grove Development of Regional Impact (DRI). Wetlands shown within the site boundary are permitted through ACOE permit #SAY-2006-2046. No wetlands are intended to be preserved and all mitigation requirements have been met with off-site preservation areas. The upland area of the site is generally improved pasture and former orange grove. Conceptual lake locations for storm water management are illustrated in Exhibit 8. Final lake locations and lake areas shall be determined during the site plan approval process for each parcel.

Consistency with the City's Comprehensive Plan: The Southern Grove 4 MPUD is consistent with the City's Comprehensive Plan. Policy 1.2.2.3 requires neighborhoods in the residential area to be a minimum size of 10 acres and a maximum size of 750 acres. The proposed MPUD is approximately ~~344~~ 376 acres.

The agricultural operations and exemptions will cease on those portions of the property upon commencement of construction activities pursuant to policy 1.2.2.14

EXHIBIT 5

SITE INFORMATION

(A) Total Acreage:

Land Uses included within this MPUD and approximate area:

- Residential	344 <u>376</u> acres
<hr style="width: 50%; margin-left: 0;"/>	
TOTAL	344 <u>376</u> acres

See Exhibit 8 for MPUD Conceptual Master Plan

(B) Pedestrian Ways:

The major system of pedestrian movement will consist of sidewalks adjacent to the streets with connections to the neighborhoods. The minor systems will be developed within the neighborhoods as development occurs consistent with City of Port St. Lucie Code of Ordinances. A portion of the development area will incorporate the Tradition Trail corridor and encourage multimodal connectivity to community services and districts.

(C) Density:

Minimum Density: 1.00 units/gross acre

Maximum Density: 28.00 units/gross acre

This MPUD shall not exceed a maximum quantity of 1,300 dwelling units.

~~*note: Units not used within this development may be transferred to other developments within the DRI.~~

(D) Model Area(s):

The proposed location of model/sales areas shall be determined as individual parcels are developed and approved through the plan review process and require approval of the Site Plan Review Committee.

EXHIBIT 6

DEVELOPMENT USES AND STANDARDS

SECTION 1: RESIDENTIAL AREA

(A) Purpose. The purpose of the residential area shall be to locate and establish neighborhoods within the NCD District which are deemed to be uniquely suited for the development and maintenance of residential living of an urban and suburban character; to designate those uses and services deemed appropriate and proper for location and development within that area; and to establish development standards and provisions as are appropriate to ensure proper development in a residential environment. Residential areas shall contain integrated neighborhoods within a 2-mile radius of shops, services and other activities. Neighborhoods within the residential area shall be a minimum of ten (10) acres and a maximum of seven-hundred fifty (750) acres. Gated neighborhoods are permitted provided arterial roads are not gated and they are integrated into the overall community via pedestrian and bicycle connections. Higher density residential uses within the Residential area shall be encouraged to be located near Neighborhood/village areas, Town Centers, Mixed Use areas, central focal points, and the center or edge of neighborhood areas. The following standards shall be met in designing neighborhoods within the residential area.

(B) Permitted Principal Uses and Structures. Neighborhoods within the Residential area may include the following principal uses and structures.

- 1) Single-family dwelling (attached and detached);
- 2) ~~Single family~~ Paired villa or duplex;
- 3) Single unit accessory apartments, home offices or studios with a maximum living area of 600 square feet shall be permitted above garages on residential lots;
- 4) Townhouse dwelling;
- 5) Multiple-family vertically attached dwelling;
- 6) ~~Rental Community~~ Multi-Family Horizontal – single family cottages and duplexes (excluding mobile homes)
- 7) Park or playground, or other public or private recreation or cultural facility (including but not limited to: Golf course or clubhouse, with or without an alcoholic beverage license for sale of alcoholic beverages to members and guests of the clubhouse; Open space devoted to the conservation and maintenance of natural waterways, vegetation and wild life; Hiking and/or bicycle trails; Nature study areas and boardwalks; Picnic areas);
- 8) Civic, institutional or cultural facility (including but not limited to churches or other places of worship, day care centers, schools (public or private), kindergarten through 12th grade, congregate living facilities;
- 9) Temporary sales trailers located upon the parcel for which sales activities are to be conducted.

- (C) Special Exception Uses. The following uses may be permitted only following the review and specific approval thereof by the City Council:

Wireless communication antennas and monopole towers with a maximum height of 100 feet located within a public recreation areas or school sites, provided all other criteria as set forth in Section 158.213, City of Port St. Lucie Zoning Ordinances.

- (D) Accessory Uses: As set forth within Section 2 hereof.

- (E) Minimum Lot Requirements / Maximum Residential Density:

1) Single-family dwelling: Three thousand five hundred (3,500) square feet and width of thirty-five (35) feet, with a maximum gross project density of fifteen (15) dwelling units per acre;

2) Townhouse dwelling: One thousand four hundred (1,400) square feet and a width of eighteen (18) feet, with a maximum gross project density of twenty-eight (28) dwelling units per acre.

3) Multiple-family vertically attached dwelling: Five (5) acres and width of one hundred fifty (150) feet, with a minimum gross project density of ten (10) units per acre and maximum gross project density of twenty-eight (28) dwelling units per acre.

4) Paired Villa or Duplex dwelling: Five thousand two hundred eighty (5,280) square feet and minimum width of forty-eight (48) feet, with a maximum gross project density of twenty-eight (28) dwelling units per acre. Villa/Duplex product is considered a combination of two lots with one villa/duplex unit (two dwelling units).

5) ~~Rental Community~~ Multi-Family Horizontal: Five (5) acres and width of one hundred fifty (150) feet, with a minimum gross project density of ~~ten (10)~~ five (5) units per acre and maximum gross project density of twenty-eight (28) dwelling units per acre. (Cottages and duplexes)

6) All other permitted or special exception uses: Twenty thousand (20,000) square feet and a width of one hundred (100) feet.

- (F) Maximum Building Lot Coverage: Sixty (60) percent provided that the maximum impervious surface does not exceed eighty (80) percent.

- (G) Minimum Open Space: Thirty (30) percent. Within open space areas include a minimum of 5% useable open space in the form of squares, greens, parks, recreation areas and/or conservation areas.

- (H) Maximum Building Height: Thirty-five (35) feet, measured to midpoint of roof pitch, provided that steeples and similar architectural embellishments shall have a maximum height of sixty (60) feet.

- (I) Minimum Living Area:

1) Single-family dwelling: One thousand two hundred (1,200) square feet.

2) Townhouse, Paired Villa, Duplex, Cottage, Multiple-family dwellings:

- a. Studio apartment, five hundred (500) square feet;
- b. One (1) bedroom, six hundred (600) square feet;
- c. Two (2) bedroom, eight hundred (800) square feet;
- d. Three (3) bedroom, nine hundred (900) square feet.

(J) Yard Requirements and Buffering: Minimum setbacks shall be stated below unless otherwise indicated on Exhibit 10 of the Southern Grove - 4 MPUD.

1. Single-family dwelling:
 - (a) Front yard. Each lot shall have a front yard with a building setback line of fifteen (15) feet and a front load garage setback line of eighteen (18) feet. Each lot having frontage on a non-gated collector road shall have a front yard with a building setback line of twenty-five (25) feet.
 - (b) Side Yard: Each lot shall have two (2) side yards of five (5) feet in width and shall result in a minimum separation of ten (10) feet between adjacent buildings. A side yard of fourteen (14) feet shall be provided adjacent to a right-of-way.
 - (c) Rear Yard: Each lot shall have a rear yard with a building setback line of ten (10) feet.
2. ~~Single-family~~ Paired Villa or Duplex:
 - (a) Front Yard: Each lot shall have a front yard with a building setback line of fifteen (15) feet and a front load garage setback line of eighteen (18) feet.
 - (b) Side Yard: Each lot shall have two (2) side yards five (5) feet in width and shall result in a minimum separation of ten (10) feet between adjacent buildings. A side yard of fourteen (14) feet shall be provided adjacent to a right-of-way. Lots shall have a zero foot setback on the zero lot line side of the lot and a side yard setback of five (5) feet on the non-zero foot lot line.
 - (c) Rear Yard: Each lot shall have a rear yard with a building setback line of ten (10) feet.
3. Townhouse dwelling:
 - (a) Each townhouse dwelling shall have a front yard with a minimum depth of ten (10) feet, a front load garage setback line of eighteen (18) feet, and a rear yard with a minimum depth of ten (10) feet. Screened enclosures shall be set back a minimum of five (5) feet from the rear property line. Each townhouse dwelling having frontage on a non-gated collector road shall have a front yard with a building setback line of twenty-five (25) feet.
 - (b) No less than three (3) townhouse dwellings and no more than eight (8) townhouse dwellings shall be contiguous. No contiguous group of dwellings shall exceed two hundred forty (240) feet in length.
 - (c) No portion of a townhouse or accessory structure in or related to one (1) group of contiguous townhouses shall be closer than fifteen (15) feet to any portion of a townhouse or accessory structure related to another group. A side yard having a minimum depth of ten (10) feet shall be provided between the side of any townhouse dwelling and a private or public street or right-of-way.
4. ~~Rental Community~~ Multi-Family Horizontal:
 - ~~Each rental~~ community development shall have a setback of ~~fifteen (15)~~ twenty-five (25) feet from the front yard and road rights of way, and ten (10) foot from side and rear property lines. Where two or more ~~rental~~ buildings are situated upon a parcel, any two buildings shall be separated by a minimum of ten (10) feet.

5. Multiple-Family Vertically Attached dwelling:
Each multi-family development shall have a setback of twenty-five (25) feet from the front yard and road rights-of-way and ten (10) feet from side and rear property lines. Where two or more buildings are situated upon a parcel, any two buildings shall be separated by a minimum of twenty (20) feet. No building shall have an effective length of mass exceeding three hundred (300) feet.
6. All other permitted, non-residential, or special exception uses:
Setback requirements shall be fifteen (15) feet for front yard and from ~~public~~ private rights-of-way, ~~twenty-five (25) feet from public rights-of-way~~, and ten (10) feet from side and rear property lines. Special exception uses shall require a minimum setback of twenty-five (25) from all property lines and rights-of-way.
7. Buffering: Where applicable, buffering shall be provided in accordance with the landscaping requirements of Chapter 154, City of Port St. Lucie Ordinances. All mechanical equipment shall be screened from public view. The screening shall be designed as both a visual barrier and a noise barrier.

(K) Off-Street Parking and Service Requirements: As set forth in Section 3 hereof.

(L) Site Plan Review: Each neighborhood within the Residential area shall submit a conceptual plan meeting the criteria set forth above and those criteria contained in the NCD District's Policies of the City of Port St. Lucie's Comprehensive Plan. Conceptual Plans shall be submitted for review and approved by the Planning and Zoning Director or the City's Site Plan Review Committee prior to approval of subdivision plats. Conceptual plans shall include adequate information to determine compliance with the required design standards set forth above, including but not limited to proximity to shops and services, lot sizes and setbacks, and minimum open space. An exhibit indicating building envelopes/setbacks shall be provided with each conceptual plan or subdivision plat submittal. Multi-Family, ~~rental community~~, and non-residential developments within the Residential area shall submit a site plan meeting the criteria set forth above for review and approval by the City's Site Plan Review Committee.

A conceptual plan shall include general street network, dwelling unit types and lot types, number of units, general lot sizes and setbacks, conceptual drainage, pedestrian & bike paths, preservation areas, and open space areas.

(M) Access: Gated subdivisions shall provide a minimum distance of 100' from the gate to the right-of-way. There shall also be provided space for buses and trucks to maneuver around before the gated entrance. Secondary resident restricted entrances shall provide a minimum distance of 100' form the gate to the right-of-way.

SECTION 2: ACCESSORY USES AND STRUCTURES

- (A) General Provisions: Accessory structures and uses are permitted in connection with any principal lawfully existing permitted use, provided that all accessory structures or uses are in full compliance with all setback, height, building coverage and other requirements. In no case shall accessory uses, either separately or in combination, exceed more than twenty (20) percent of the total floor area of the principal building or ground area of any lot, whichever is more restrictive.

(B) Accessory Uses in Residential Areas:

1. Accessory uses or structures shall not be located in that area extending from the front building line to the front property line unless otherwise specifically provided. Accessory uses or structures shall be located a minimum of five (5) feet from the rear property line, except where lakes or open space areas are adjacent to the rear property line and setback may be reduced to two (2) feet. The minimum setback from the side property lines shall be three (3) feet, provided ten (10) feet shall be provided adjacent to a right-of-way. A ten (10) foot minimum setback shall be provided for accessory uses associated with multiple-family development.
2. Accessory uses as permitted by Section 158.217 of the City of Port St. Lucie Zoning Code are allowed in the residential area.

(C) Accessory Uses in Non-Residential Areas:

1. Accessory uses or structures shall not be located in that area extending from the front building line to the front property line unless otherwise specifically provided. Accessory uses or structures shall be located a minimum of ten (10) feet from the rear property line, except where lakes or open space areas are adjacent to the rear property line, then the setback may be reduced to two (2) feet. The minimum setback from the side property lines shall be three (3) feet, provided ten (10) feet shall be provided adjacent to a right-of-way.

(D) Home Occupation: A home occupation shall be permitted within residential areas, subject to the provisions of Section 158.217(F).

SECTION 3: PARKING AND PEDESTRIAN REQUIREMENTS

(A) Parking Requirements: Each building, use, or structure shall be provided with on-street and / or off-street parking and service facilities in accordance with the provisions set forth herein. The maximum number of parking spaces to be provided is limited to one hundred twenty-five (125) percent of that required by the provisions set forth herein. On-street parking spaces directly and fully adjacent to a site and available to a development shall be counted toward the maximum. Maximum driveway widths for residential units shall be 26 feet. Dwelling units with garage spaces may include the garage spaces as required parking spaces.

1. Residential (single family, ~~rental villa or duplex~~, ~~rental cottage~~, multi-family horizontal): 1.5 spaces per dwelling unit.
2. Residential (multifamily vertical and townhomes): 1.75 spaces per dwelling unit plus 1 space for every 5 dwelling units.
3. Parks and Recreation:
 - a) Private Facilities: No parking required provided adequate pedestrian access exists within the area intended to be served by the facility.
 - b) Public Facilities: All parking requirements shall be established for each specific use as part of the site plan review process.

(B) Shared or joint use of parking facilities between and among uses is authorized when:

1. There is a relationship among the land uses utilizing shared parking that will attract drivers to two or more uses in a single trip; and,

2. There is adequate linkage between the parking and each of the uses sharing the parking.
- (C) Parking lot landscaping shall be in accordance with Chapter 153, City of Port St. Lucie Zoning Ordinances except that ten (10) foot parking islands shall be required to break up rows in groups of twelve (12) contiguous spaces.

(D) Pedestrian Access:

1. An on-site pedestrian and bike circulation system which links the street and the primary entrance(s) of the structure(s) on the site shall be provided with each conceptual plan or site plan. Sidewalks or pedestrian ways must connect the required pedestrian system to existing pedestrian systems on adjacent developments if adequate safety and security can be maintained.
2. The circulation system must be hard-surfaced, ADA acceptable, and be at least 5 feet wide.

SECTION 4: LANDSCAPING

(A) Plant Material:

1. Tree species height, spread and minimum clear trunk and shrub heights shall meet or exceed the minimum specified by the USDA's Grades and Standards for Nursery Stock, current edition. Each tree in a grouping shall be counted separately.
2. Tree species shall be a minimum of fourteen (14) feet overall height when planted with a minimum four (4) foot spread in accordance with the USDA's Grades and Standards for Nursery Stock, current edition.
3. Existing plant material used to meet the intent of this section and City of Port St. Lucie Code of Ordinances, will not have to be of a quality comparable to Florida No. 1 since this material was not nursery grown.
4. No more than eighty (80) percent of the required trees shall be native species.
5. No less than twenty-five (25) percent of all required trees shall be native species.

(B) Easement and Utility Area Landscaping: Trees and all vegetation with intrusive root systems shall not be planted within ten (10) feet of any utilities; including water and sewer lines, exiting utility pole, guy wire, and pad mounted transformers. No protective barriers will be required. All proposed utilities shall maintain separation distances from all City mains as required by the city and FDEP.

(C) Residential Landscaping: The number of trees to be provided per lot shall be as follows:

- A. Lots less than 6,000 sf shall provide two (2) trees.
- B. Lots from 6,000 to 7,000 sf shall provide three (3) trees.
- C. Lots over 7,500 sf shall provide four (4) trees.

(D) Perimeter landscape requirements adjacent to lakes may be relocated to other areas within the project site to allow creativity in landscape design adjacent to the lake (up to 100% of required landscape).

- (E) Adjacent to Collector and Arterial roadways: The 6' fence or wall is at the discretion of the developer; however, the minimum City of Port St. Lucie landscape (plant material) requirements shall be met.
- (F) Perimeter landscape buffer strips along a public right-of-way shall be a minimum of 20' wide. All other perimeter buffer strips shall be a minimum of 10' wide with or without a wall. Landscape buffer strips for interior parcels within the MPUD may be a minimum of five (5) feet between adjacent parcels or where parking areas are interconnected, provided an area equal to a ten (10) foot buffer is provided elsewhere on site.

SECTION 5: UTILITIES

(A) Proposed Sanitary Sewer System:

The proposed Southern Grove project is located within the City of Port St. Lucie Water and Sewer Service Area. The proposed Sanitary Sewer System for Southern Grove project will consist of Gravity Sanitary Sewer Mains and Manholes, which will flow to on-site Sewage Pump Stations. The proposed maximum depth of gravity sewer mains and number of pump stations are dependent on the existing soil conditions and may vary due to those existing soil conditions. The Developer shall minimize the number of pump stations designed and installed. The proposed wastewater pump stations will have force mains, which will carry the flows to the existing City of Port St. Lucie wastewater transmission system. The existing City of Port St. Lucie wastewater transmission system consists of an existing Force Main on Village Parkway. The proposed sewer transmission system will include force main connections to the existing City force main. All proposed pump stations shall require a connection to the existing fiber optics system for communication purposes.

(B) Proposed Water Distribution System:

The proposed Southern Grove project is located within the City of Port St. Lucie Water and Sewer Service Area. The proposed Water Distribution System for Southern Grove project will consist of a large Water Main along the Village Parkway that runs along the eastern boundary of the subject property. There will be several connections to the Village Parkway main, and these water mains will be extended along all other roadways within the project. The proposed water mains will be connected to the existing City of Port St. Lucie potable water system. The existing City of Port St. Lucie potable water system consists of large water mains on Discovery Way, Village Parkway, and along the proposed Community Blvd roadway, located on the perimeter of the Southern Grove site. The proposed water main connections for the site will include multiple water connections on all sides of the project.

SECTION 6: TRADITION TRAIL

Provisions for Tradition Trail shall be provided within this development. A fence or wall may be utilized to separate the private development areas from the public trail system.

~~The proposed Tradition Trail (when developed by the City of Port St. Lucie and/or the master developer of Tradition) shall be allowed to cross private residential streets if necessary. A formalized pedestrian crossing shall occur at any private residential street and pedestrian awareness signs identifying Tradition Trail and the road crossings shall be implemented. No fencing or other security measures shall block use and continuation of the public trail along the perimeter of the development.~~

EXHIBIT 7 (existing)

SKETCH AND LEGAL DESCRIPTION

LEGAL DESCRIPTION:

A PORTION OF PARCEL 28 ACCORDING TO THE PLAT OF SOUTHERN GROVE PLAT NO. 3, AS RECORDED IN PLAT BOOK 61, PAGE 17, PUBLIC RECORDS OF ST. LUCIE COUNTY, FLORIDA, LESS AND EXCEPT THAT PART FOR COMMUNITY BOULEVARD AS DESCRIBED BY DEED RECORDED IN OFFICIAL RECORDS BOOK 3935 AT PAGE 2995, PUBLIC RECORDS OF ST. LUCIE COUNTY, FLORIDA, AND MORE PARTICULARLY DESCRIBED AS FOLLOWS:

BEGINNING AT THE NORTHWEST CORNER OF PARCEL 28 OF THE ABOVE MENTIONED SOUTHERN GROVE PLAT NO. 3, THENCE NORTH 09°00'00" EAST, A DISTANCE OF 823.87 FEET TO THE BEGINNING OF A CURVE TO THE RIGHT THROUGH AN ANGLE OF 26° 33' 21", FOR AN ARC LENGTH OF 1355.70 FEET, HAVING A RADIUS OF 2925.00 FEET, AND WHOSE CHORD BEARS SOUTH 76° 43' 19" EAST FOR A DISTANCE OF 1343.60 FEET; THENCE SOUTH 63°26'39" EAST, A DISTANCE OF 1026.51 FEET TO THE BEGINNING OF A CURVE TO THE LEFT THROUGH AN ANGLE OF 26° 33' 04", FOR AN ARC LENGTH OF 1424.97 FEET, HAVING A RADIUS OF 3075.00 FEET, AND WHOSE CHORD BEARS SOUTH 76° 43' 11" EAST FOR A DISTANCE OF 1412.25 FEET; THENCE, SOUTH 89°59'43" EAST, A DISTANCE OF 772.17 FEET TO A POINT OF INTERSECTION WITH THE WEST LINE OF THAT CERTAIN FPL EASEMENT AS RECORDED IN OFFICIAL RECORDS BOOK 97, PAGE 505, OF THE PUBLIC RECORDS OF ST. LUCIE COUNTY, FLORIDA; THENCE, ALONG SAID WEST LINE, SOUTH 00°02'34" WEST, A DISTANCE OF 1071.58 FEET; THENCE, NORTH 88°09'35" WEST, A DISTANCE OF 174.90 FEET; THENCE, NORTH 59°39'57" WEST, A DISTANCE OF 339.85 FEET; THENCE, NORTH 86°10'52" WEST, A DISTANCE OF 139.67 FEET; THENCE, NORTH 84°50'59" WEST, A DISTANCE OF 141.44 FEET; THENCE, NORTH 39°22'02" WEST, A DISTANCE OF 145.89 FEET; THENCE, NORTH 04°53'53" WEST, A DISTANCE OF 190.67 FEET; THENCE, NORTH 53°33'23" WEST, A DISTANCE OF 126.97 FEET; THENCE, NORTH 82°12'24" WEST, A DISTANCE OF 76.76 FEET; THENCE, SOUTH 88°19'34" WEST, A DISTANCE OF 298.14 FEET; THENCE, SOUTH 00°21'19" WEST, A DISTANCE OF 1374.53 FEET; THENCE, NORTH 89°42'37" EAST, A DISTANCE OF 743.35 FEET; THENCE, SOUTH 00°00'00" EAST, A DISTANCE OF 972.53 FEET; THENCE, NORTH 90°00'00" WEST, A DISTANCE OF 20.00 FEET TO THE BEGINNING OF A NON-TANGENTIAL CURVE TO THE RIGHT THROUGH AN ANGLE OF 78° 26' 50", FOR AN ARC LENGTH OF 527.03 FEET, HAVING A RADIUS OF 395.00 FEET, AND WHOSE CHORD BEARS SOUTH 56° 32' 03" WEST FOR A DISTANCE OF 488.80 FEET; THENCE, SOUTH 17°40'40" WEST, A DISTANCE OF 17.58 FEET; THENCE, NORTH 72°19'20" WEST, A DISTANCE OF 629.53 FEET TO THE BEGINNING OF A CURVE TO THE LEFT THROUGH AN ANGLE OF 17° 35' 06", FOR AN ARC LENGTH OF 1557.60 FEET, HAVING A RADIUS OF 5075.00 FEET, AND WHOSE CHORD BEARS NORTH 81° 06' 53" WEST FOR A DISTANCE OF 1551.50 FEET; THENCE, NORTH 89°54'26" WEST, A DISTANCE OF 1359.89 FEET; THENCE, NORTH 00°00'50" EAST, A DISTANCE OF 2052.00 FEET; THENCE, SOUTH 89°59'54" WEST, A DISTANCE OF 611.21 FEET; THENCE, NORTH 00°05'34" EAST, A DISTANCE OF 562.33 FEET TO THE BEGINNING OF A CURVE TO THE LEFT THROUGH AN ANGLE OF 10° 44' 31", FOR AN ARC LENGTH OF 415.27 FEET, HAVING A RADIUS OF 2215.00 FEET, AND WHOSE CHORD BEARS NORTH 05° 16' 42" WEST FOR A DISTANCE OF 414.68 FEET TO THE BEGINNING OF A CURVE TO THE RIGHT THROUGH AN ANGLE OF 10° 44' 31", FOR AN ARC LENGTH OF 387.15 FEET, HAVING A RADIUS OF 2065.00 FEET, AND WHOSE CHORD BEARS NORTH 05° 16' 42" WEST FOR A DISTANCE OF 386.60 FEET; THENCE, NORTH 00°05'34" EAST, A DISTANCE OF 321.67 FEET TO THE POINT OF BEGINNING.

CONTAINING 314.223 ACRES, MORE OR LESS.
SUBJECT TO EASEMENTS, RESERVATIONS, AND/OR RIGHTS-OF-WAY OF RECORD.

TOGETHER WITH:

A PORTION OF PARCEL 28 ACCORDING TO SOUTHERN GROVE PLAT NO.3, AS RECORDED IN PLAT BOOK 61, PAGE 17, PUBLIC RECORDS OF ST. LUCIE COUNTY, FLORIDA AND BEING MORE PARTICULARLY DESCRIBED AS FOLLOWS:

BEGINNING AT THE NORTHERLY NORTHEAST CORNER OF PARCEL 28 OF THE ABOVE MENTIONED SOUTHERN GROVE PLAT NO. 3, THENCE SOUTH 44°59'52" EAST, A DISTANCE OF 42.43 FEET; THENCE SOUTH 00°00'00" EAST, TO THE WEST RIGHT-OF-WAY LINE OF VILLAGE PARKWAY, A DISTANCE OF 14.19 FEET TO A POINT OF CURVATURE OF A CURVE CONCAVE TO THE EAST, HAVING A RADIUS OF 4119.00 FEET; THENCE SOUTHERLY, ALONG THE ARC OF SAID CURVE AND ALONG SAID WEST RIGHT-OF-WAY LINE THROUGH A CENTRAL ANGLE OF 11°51'40", A DISTANCE OF 852.70 FEET; THENCE SOUTH 11°51'40" EAST, ALONG SAID WEST RIGHT-OF-WAY LINE OF VILLAGE PARKWAY, A DISTANCE OF 675.54 FEET TO A POINT OF CURVATURE OF A CURVE CONCAVE TO THE EAST, HAVING A RADIUS OF 3969.00 FEET; THENCE SOUTHERLY, ALONG THE ARC OF SAID CURVE AND ALONG SAID WEST RIGHT-OF-WAY LINE THROUGH A CENTRAL ANGLE OF 01°55'36", A DISTANCE OF 133.47 FEET; THENCE DEPARTING SAID WEST RIGHT-OF-WAY LINE, NORTH 90°00'00" WEST, A DISTANCE OF 934.21 FEET TO A POINT OF INTERSECTION WITH THE EAST LINE OF THAT CERTAIN FPL EASEMENT AS RECORDED IN DEED BOOK 234, PAGE 102, AND DEED BOOK 236, PAGE 134, OF THE PUBLIC RECORDS OF ST. LUCIE COUNTY, FLORIDA; THENCE, ALONG SAID EAST LINE, NORTH 00°02'34" EAST, A DISTANCE OF 1683.05 FEET TO THE NORTH LINE OF SAID PARCEL 28; THENCE, ALONG SAID NORTH LINE, SOUTH 89°59'43" EAST, A DISTANCE OF 650.91 FEET TO THE POINT OF BEGINNING.

CONTAINING 30.000 ACRES OF LAND, MORE OR LESS.
SUBJECT TO EASEMENTS, RESTRICTIONS, RESERVATIONS, COVENANTS, AND RIGHTS-OF-WAY OF RECORD.
CONTAINING A COMBINED 344.223 ACRES, MORE OR LESS.

SHEET 1 OF 14



CAULFIELD & WHEELER, INC.
CIVIL ENGINEERING
LANDSCAPE ARCHITECTURE - SURVEYING
7900 GLADES ROAD - SUITE 100
BOCA RATON, FLORIDA 33434
PHONE (561)-392-1991 / FAX (561)-750-1452

RONNIE L. FURNISS
PROFESSIONAL SURVEYOR
AND MAPPER LS6272
STATE OF FLORIDA
L.B. 3591

DATE	8/05/2020
DRAWN BY	RLF
F.B./ PG.	N/A
SCALE	AS SHOWN
JOB NO.	8993

**SG4 MPUD
SKETCH OF DESCRIPTION**

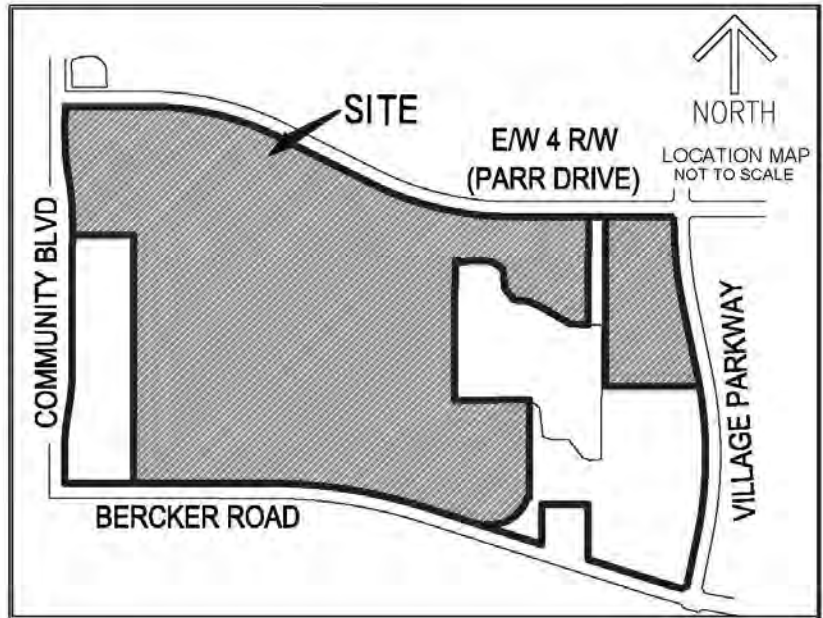

LEGAL DESCRIPTION:

ALL OF PARCEL 28 ACCORDING TO THE PLAT OF SOUTHERN GROVE PLAT NO. 3, AS RECORDED IN PLAT BOOK 61, PAGE 17, PUBLIC RECORDS OF ST. LUCIE COUNTY, FLORIDA, LESS AND EXCEPT THAT PART FOR COMMUNITY BOULEVARD AS DESCRIBED BY DEED RECORDED IN OFFICIAL RECORDS BOOK 3935 AT PAGE 2995, PUBLIC RECORDS OF ST. LUCIE COUNTY, FLORIDA, CONTAINING 436.727 ACRES OF LAND, MORE OR LESS.

NOTES:

1. REPRODUCTIONS OF THIS SKETCH ARE NOT VALID UNLESS SEALED WITH A SURVEYOR'S SEAL.
2. LANDS SHOWN HEREON ARE NOT ABSTRACTED FOR RIGHTS-OF-WAY, EASEMENTS, OWNERSHIP, OR OTHER INSTRUMENTS OF RECORD.
3. BEARINGS SHOWN HEREON ARE RELATIVE TO A PLAT BEARING OF N90°00'00"W ALONG THE NORTH LINE OF PARCEL 28 SOUTHER GROVE PLAT NO. 3, AS RECORDED IN PLAT BOOK 61, PAGE 26, OF THE PUBLIC RECORDS OF ST. LUCIE COUNTY, FLORIDA.
4. DATA SHOWN HEREON WAS COMPILED FROM INSTRUMENTS OF RECORD AND DOES NOT CONSTITUTE A FIELD SURVEY AS SUCH.

CERTIFICATE:

I HEREBY CERTIFY THAT THE ATTACHED SKETCH OF DESCRIPTION OF THE HEREON DESCRIBED PROPERTY IS TRUE AND CORRECT TO THE BEST OF MY KNOWLEDGE AND BELIEF AS PREPARED UNDER MY DIRECTION ON AUGUST 05, 2020. I FURTHER CERTIFY THAT THIS SKETCH OF DESCRIPTION MEETS THE STANDARDS OF PRACTICE SET FORTH IN CHAPTER 5J-17 ADOPTED BY THE FLORIDA BOARD OF SURVEYORS AND MAPPERS PURSUANT TO FLORIDA STATUTES 472.027.

SHEET 2 OF 14



CAULFIELD & WHEELER, INC.
 CIVIL ENGINEERING
 LANDSCAPE ARCHITECTURE - SURVEYING
 7900 GLADES ROAD - SUITE 100
 BOCA RATON, FLORIDA 33434
 PHONE (561)-392-1991 / FAX (561)-750-1452

RONNIE L. FURNISS
 PROFESSIONAL SURVEYOR
 AND MAPPER LS6272
 STATE OF FLORIDA
 L.B. 3591

DATE	8/05/2020
DRAWN BY	RLF
F.B./ PG.	N/A
SCALE	AS SHOWN
JOB NO.	8993

**SG4 MPUD
 SKETCH OF DESCRIPTION**

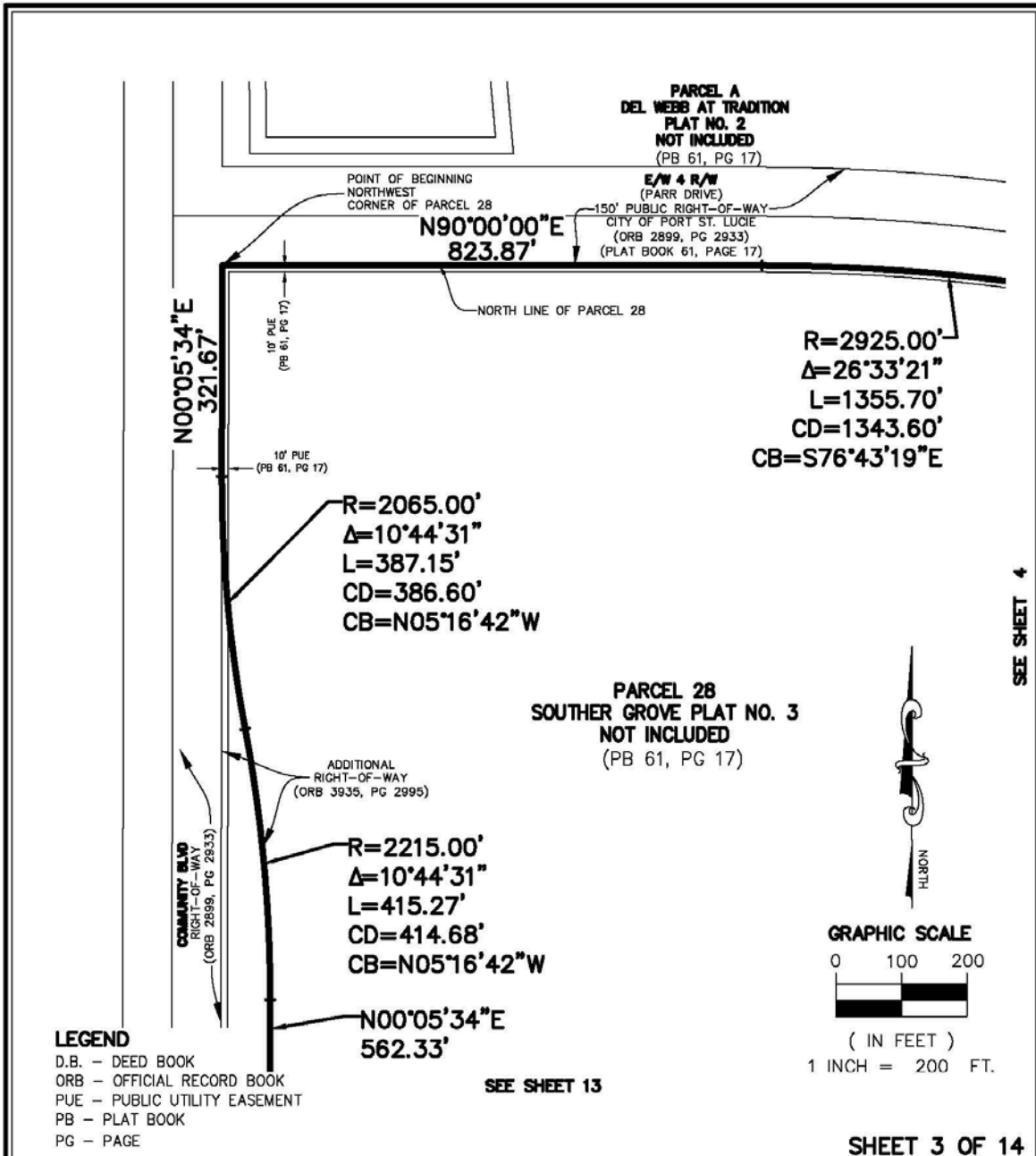

CAULFIELD & WHEELER, INC.
CIVIL ENGINEERING
LANDSCAPE ARCHITECTURE - SURVEYING
7900 GLADES ROAD - SUITE 100
BOCA RATON, FLORIDA 33434
PHONE (561)-392-1991 / FAX (561)-750-1452

**SG4 MPUD
SKETCH OF DESCRIPTION**

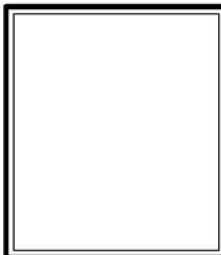

SHEET 3 OF 14

DATE	8/5/2020
DRAWN BY	RLF
F.B./ PG.	N/A
SCALE	AS SHOWN
JOB NO.	8993

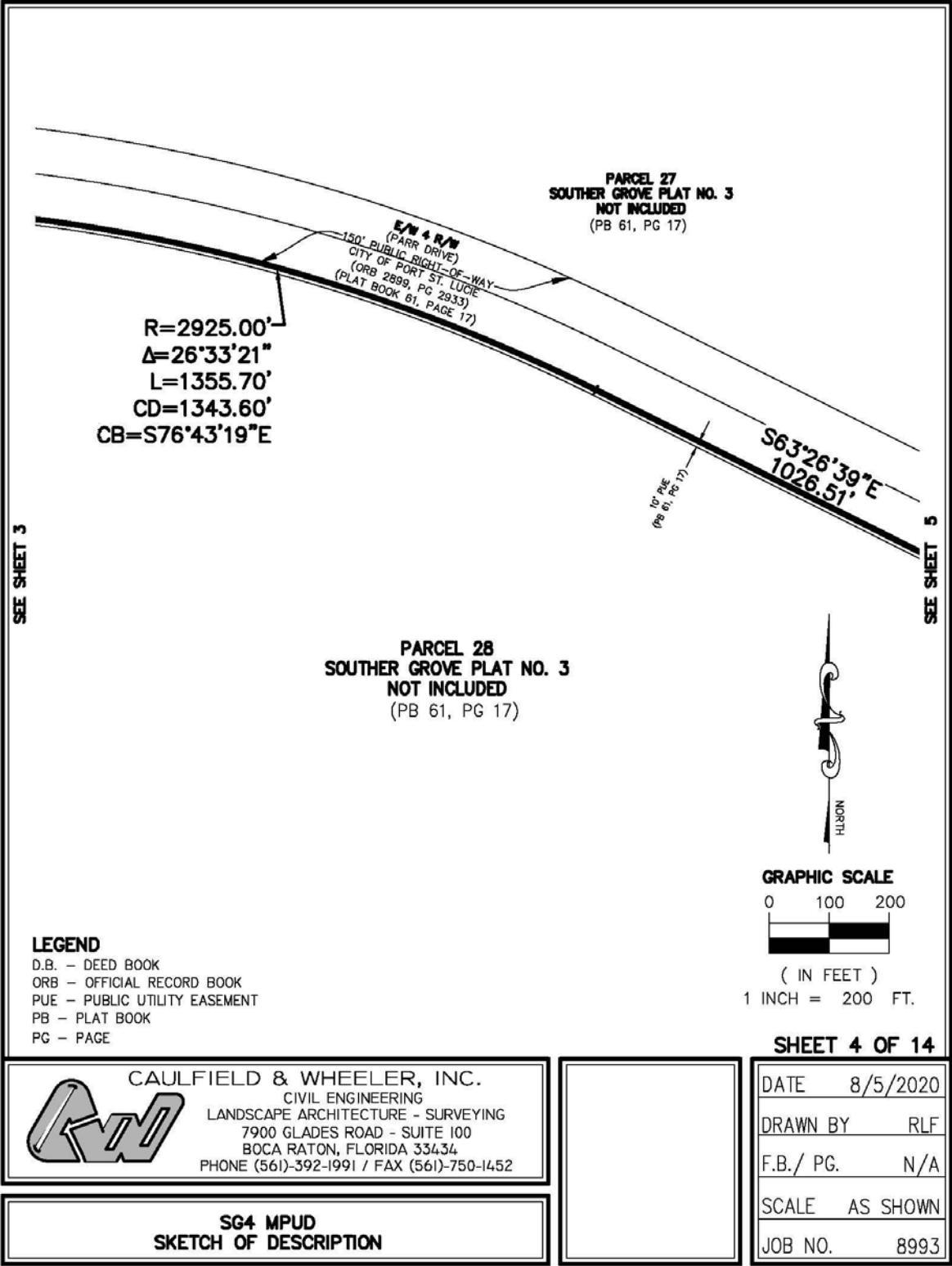

PARCEL 27
SOUTHER GROVE PLAT NO. 3
NOT INCLUDED
(PB 61, PG 17)

PARCEL 28
SOUTHER GROVE PLAT NO. 3
NOT INCLUDED
(PB 61, PG 17)

R=2925.00'
Δ=26°33'21"
L=1355.70'
CD=1343.60'
CB=S76°43'19"E

E/W + R/W
(PARR DRIVE)
150' PUBLIC RIGHT-OF-WAY
CITY OF PORT ST. LUCIE
(ORB 2899, PG 2933)
(PLAT BOOK 61, PAGE 17)

S63°26'39"E
1026.51'

10' PUE
(PB 61, PG 17)

SEE SHEET 3

SEE SHEET 5



GRAPHIC SCALE

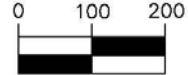

(IN FEET)

1 INCH = 200 FT.

LEGEND

- D.B. - DEED BOOK
- ORB - OFFICIAL RECORD BOOK
- PUE - PUBLIC UTILITY EASEMENT
- PB - PLAT BOOK
- PG - PAGE

SHEET 4 OF 14

	CAULFIELD & WHEELER, INC.
	CIVIL ENGINEERING
	LANDSCAPE ARCHITECTURE - SURVEYING
	7900 GLADES ROAD - SUITE 100 BOCA RATON, FLORIDA 33434
	PHONE (561)-392-1991 / FAX (561)-750-1452

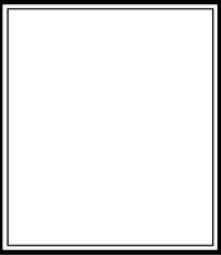

DATE	8/5/2020
DRAWN BY	RLF
F.B./ PG.	N/A
SCALE	AS SHOWN
JOB NO.	8993

**SG4 MPUD
SKETCH OF DESCRIPTION**

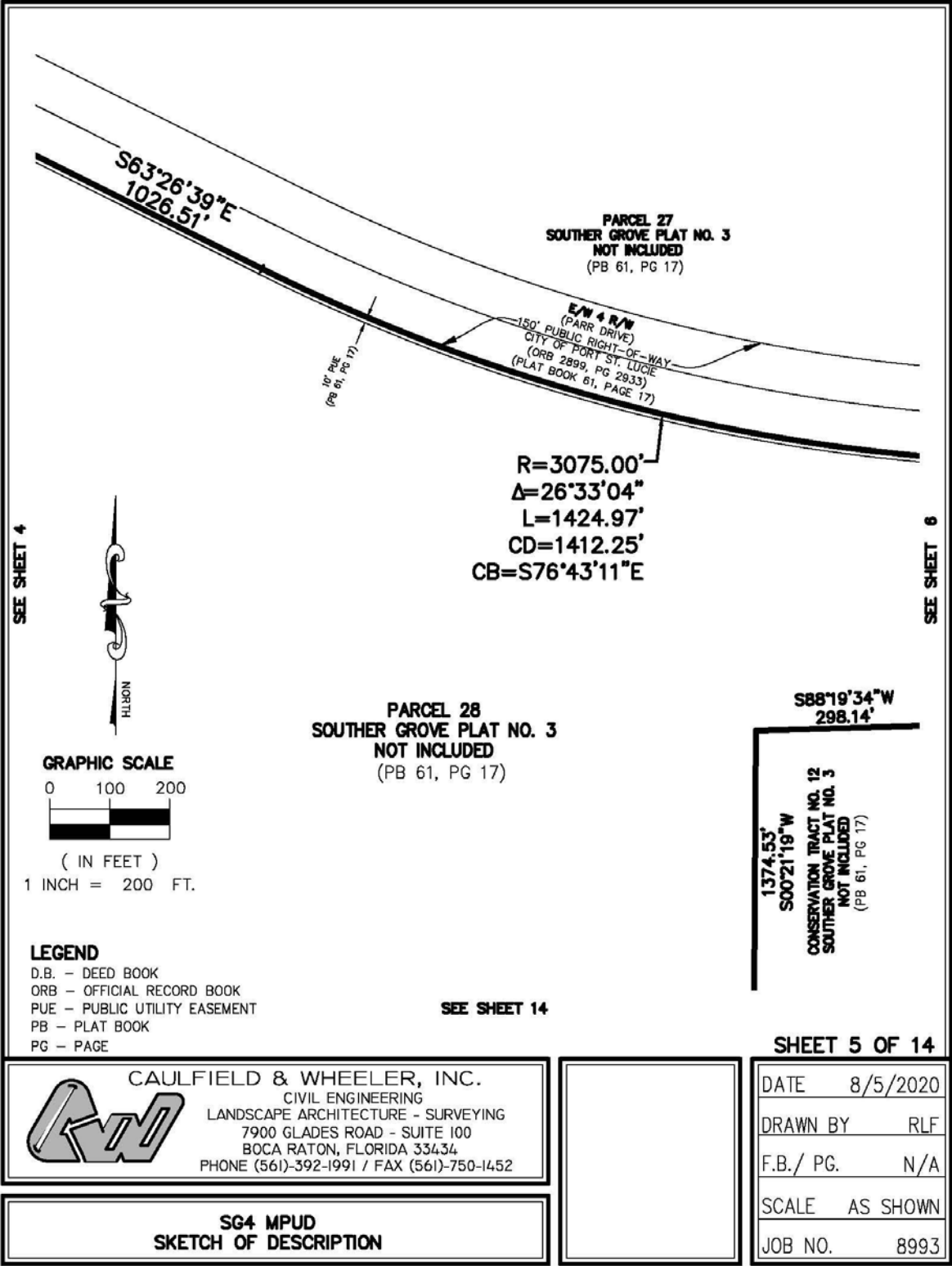

SHEET 5 OF 14

CAULFIELD & WHEELER, INC.
 CIVIL ENGINEERING
 LANDSCAPE ARCHITECTURE - SURVEYING
 7900 GLADES ROAD - SUITE 100
 BOCA RATON, FLORIDA 33434
 PHONE (561)-392-1991 / FAX (561)-750-1452

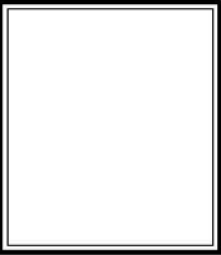

DATE	8/5/2020
DRAWN BY	RLF
F.B./ PG.	N/A
SCALE	AS SHOWN
JOB NO.	8993

SG4 MPUD
SKETCH OF DESCRIPTION

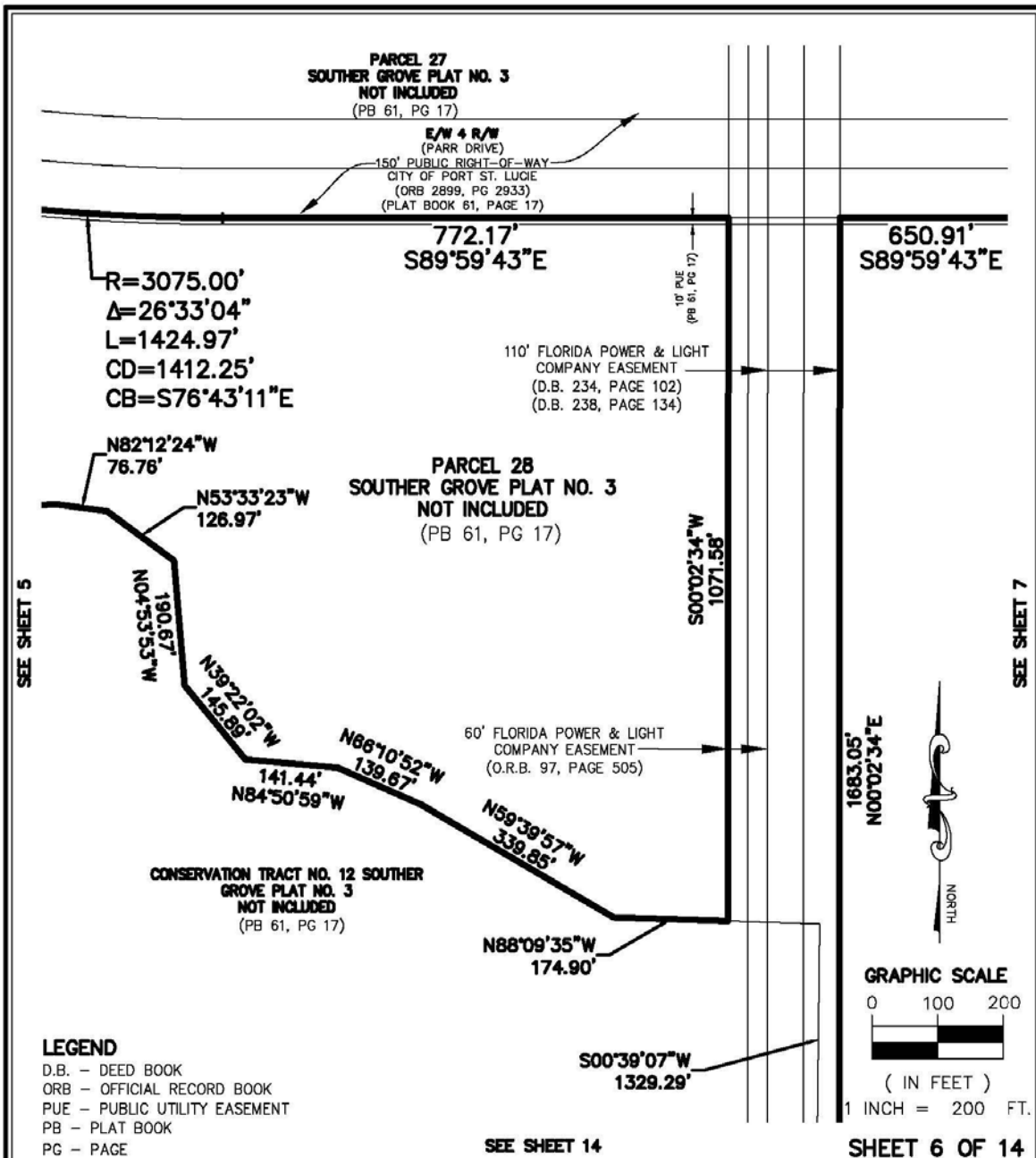

CAULFIELD & WHEELER, INC.
CIVIL ENGINEERING
LANDSCAPE ARCHITECTURE - SURVEYING
7900 GLADES ROAD - SUITE 100
BOCA RATON, FLORIDA 33434
PHONE (561)-392-1991 / FAX (561)-750-1452

SG4 MPUD
SKETCH OF DESCRIPTION

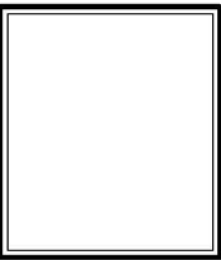

DATE	8/5/2020
DRAWN BY	RLF
F.B./ PG.	N/A
SCALE	AS SHOWN
JOB NO.	8993

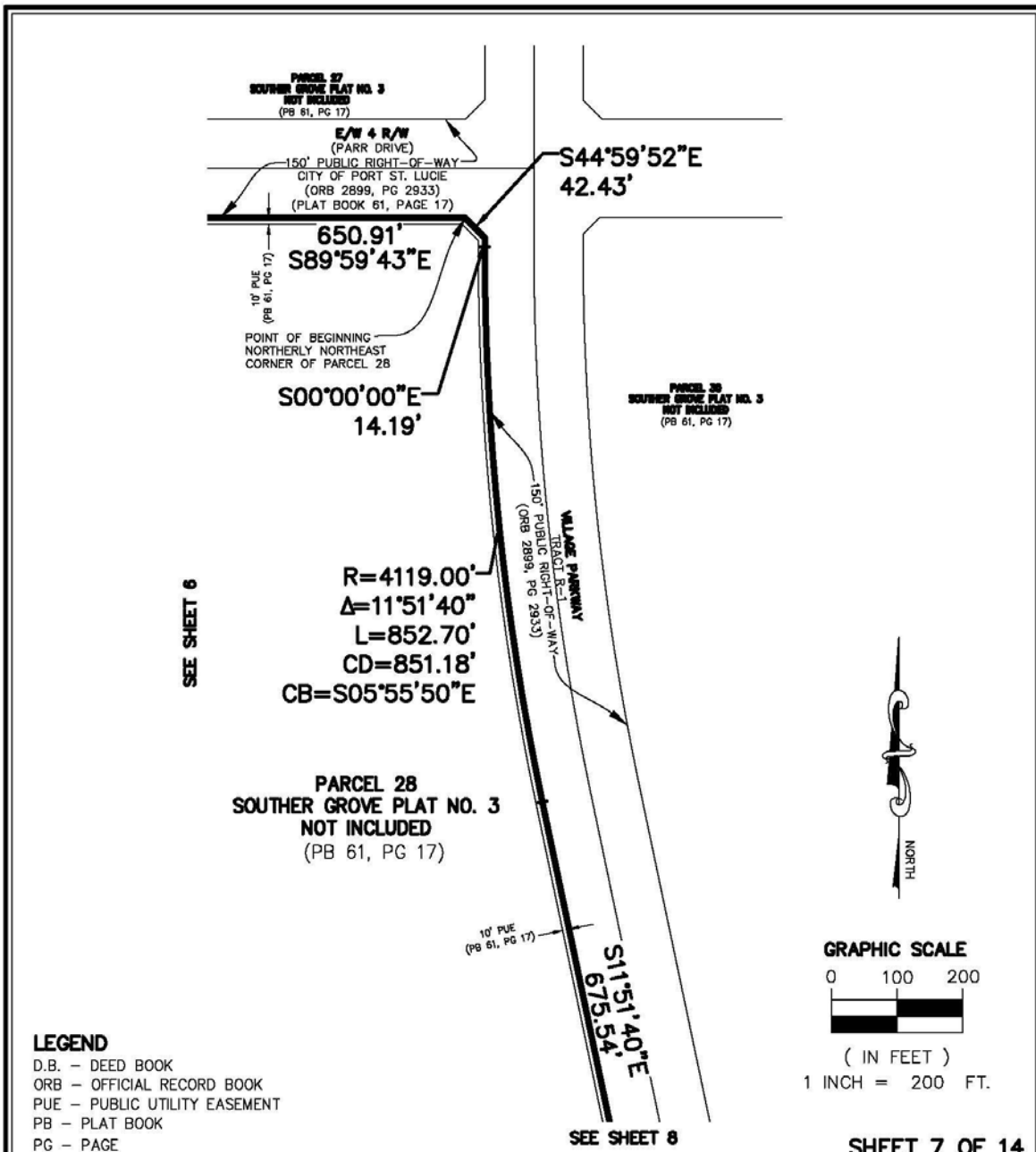

CAULFIELD & WHEELER, INC.
CIVIL ENGINEERING
LANDSCAPE ARCHITECTURE - SURVEYING
7900 GLADES ROAD - SUITE 100
BOCA RATON, FLORIDA 33434
PHONE (561)-392-1991 / FAX (561)-750-1452

SG4 MPUD
SKETCH OF DESCRIPTION

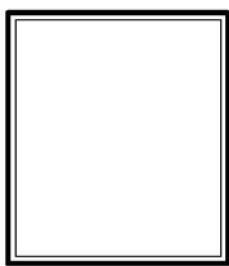

SHEET 7 OF 14

DATE	8/5/2020
DRAWN BY	RLF
F.B./ PG.	N/A
SCALE	AS SHOWN
JOB NO.	8993

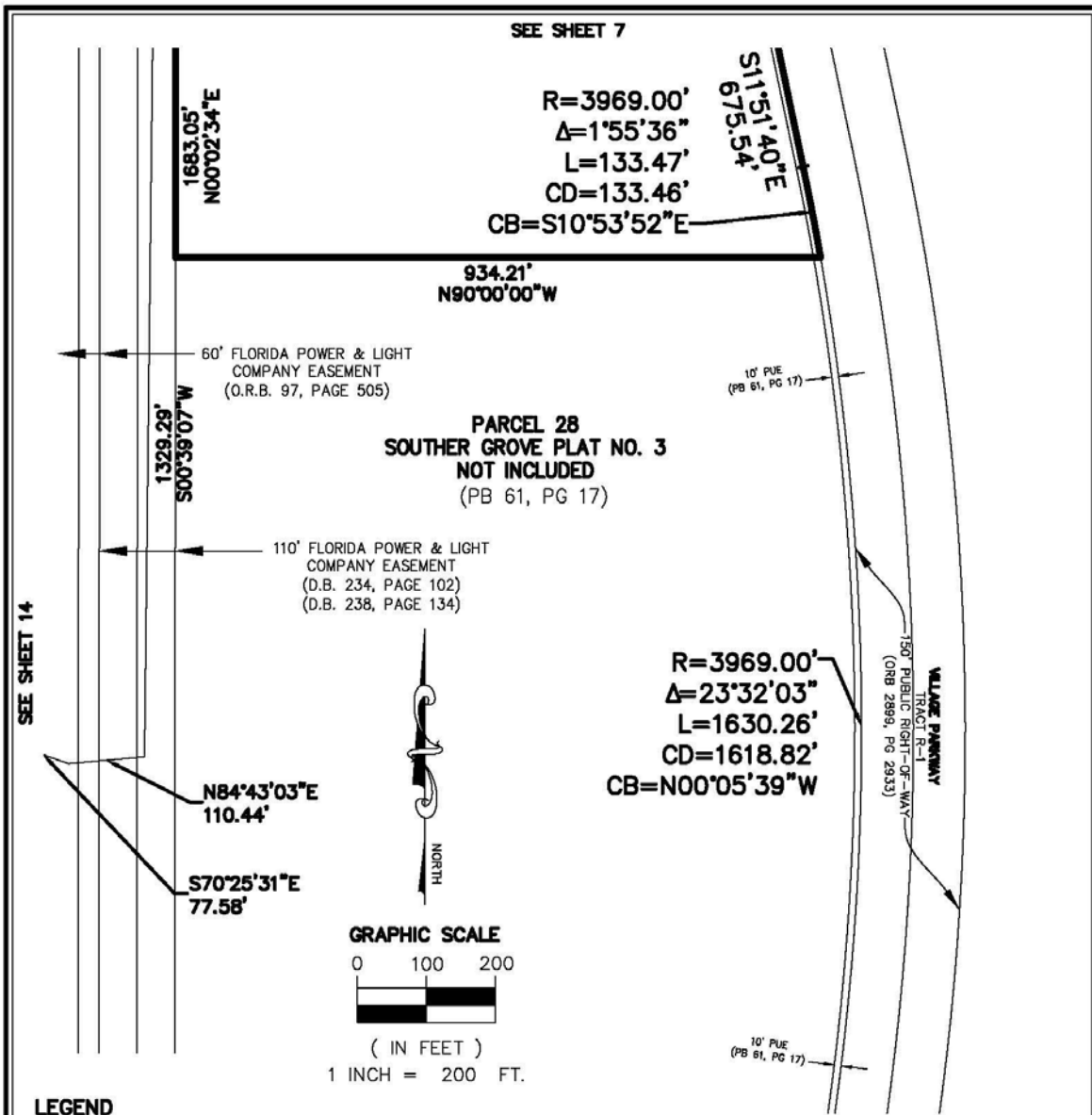

LEGEND

D.B. - DEED BOOK
ORB - OFFICIAL RECORD BOOK
PUE - PUBLIC UTILITY EASEMENT
PB - PLAT BOOK
PG - PAGE

SHEET 8 OF 14

CAULFIELD & WHEELER, INC.
CIVIL ENGINEERING
LANDSCAPE ARCHITECTURE - SURVEYING
7900 GLADES ROAD - SUITE 100
BOCA RATON, FLORIDA 33434
PHONE (561)-392-1991 / FAX (561)-750-1452



DATE	8/5/2020
DRAWN BY	RLF
F.B./ PG.	N/A
SCALE	AS SHOWN
JOB NO.	8993

**SG4 MPUD
SKETCH OF DESCRIPTION**

SEE SHEET 14



PARCEL 28
SOUTHER GROVE PLAT NO. 3
NOT INCLUDED
(PB 61, PG 17)

R=395.00'
Δ=76°26'50"
L=527.03'
CD=488.80'
CB=S56°32'03"W

N90°00'00"W
20.00'

S17°40'40"W
17.58'

N72°19'20"W
629.53'

972.53'
S00°00'00"E

S06°40'48"E
286.94'

S89°17'10"E
169.23'

S68°11'25"E
99.32'

S37°25'17"E
216.20'

N89°57'26"W
463.01'

PARCEL 28-A
SOUTHER GROVE PLAT NO. 3
NOT INCLUDED
(PB 61, PG 17)

S00°02'34"W
396.82'

SEE SHEET 10

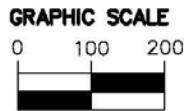
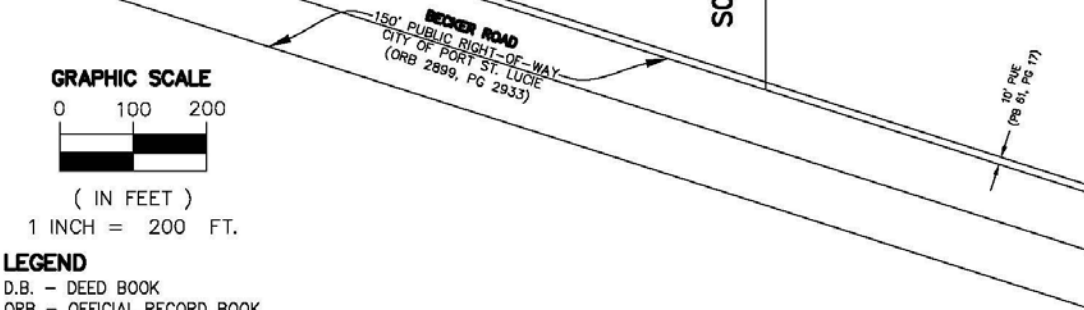

(IN FEET)
1 INCH = 200 FT.

LEGEND

- D.B. - DEED BOOK
- ORB - OFFICIAL RECORD BOOK
- PUE - PUBLIC UTILITY EASEMENT
- PB - PLAT BOOK
- PG - PAGE

SHEET 9 OF 14

CAULFIELD & WHEELER, INC.
 CIVIL ENGINEERING
 LANDSCAPE ARCHITECTURE - SURVEYING
 7900 GLADES ROAD - SUITE 100
 BOCA RATON, FLORIDA 33434
 PHONE (561)-392-1991 / FAX (561)-750-1452



DATE	8/5/2020
DRAWN BY	RLF
F.B./ PG.	N/A
SCALE	AS SHOWN
JOB NO.	8993

**SG4 MPUD
SKETCH OF DESCRIPTION**



GRAPHIC SCALE



(IN FEET)
1 INCH = 200 FT.

PARCEL 28
SOUTHER GROVE PLAT NO. 3
NOT INCLUDED
(PB 61, PG 17)

SEE SHEET 11

SEE SHEET 9

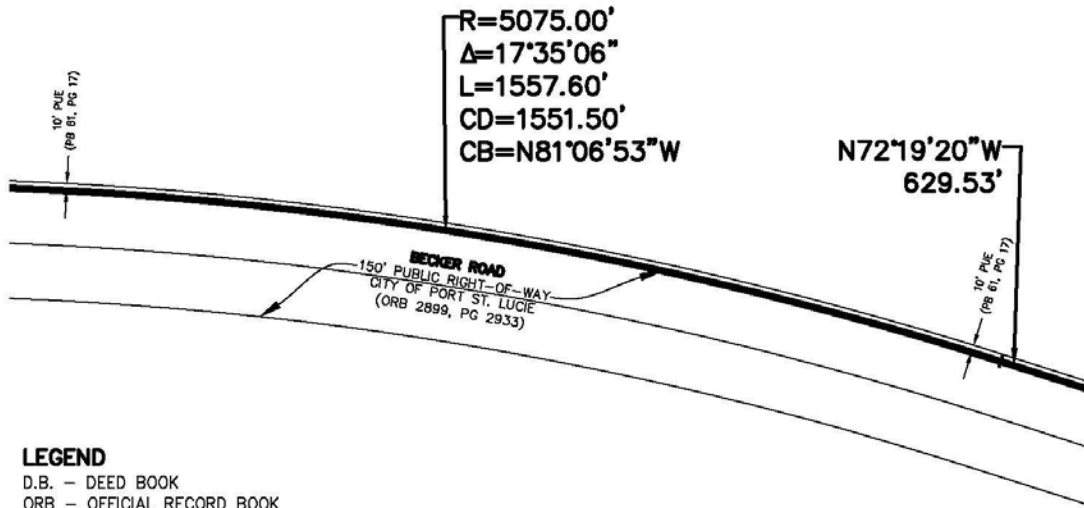

LEGEND

- D.B. - DEED BOOK
- ORB - OFFICIAL RECORD BOOK
- PUE - PUBLIC UTILITY EASEMENT
- PB - PLAT BOOK
- PG - PAGE

SHEET 10 OF 14



CAULFIELD & WHEELER, INC.
 CIVIL ENGINEERING
 LANDSCAPE ARCHITECTURE - SURVEYING
 7900 GLADES ROAD - SUITE 100
 BOCA RATON, FLORIDA 33434
 PHONE (561)-392-1991 / FAX (561)-750-1452



DATE	8/5/2020
DRAWN BY	RLF
F.B./ PG.	N/A
SCALE	AS SHOWN
JOB NO.	8993

SG4 MPUD
SKETCH OF DESCRIPTION

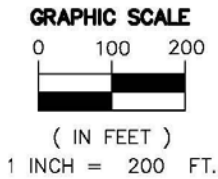

PARCEL 28
SOUTHER GROVE PLAT NO. 3
NOT INCLUDED
(PB 61, PG 17)

SEE SHEET 12

R=5075.00'
Δ=17°35'06"
L=1557.60'
CD=1551.50'
CB=N81°06'53"W

SEE SHEET 10

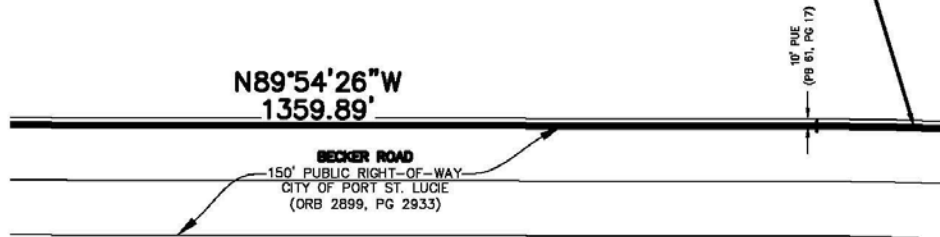

LEGEND

- D.B. - DEED BOOK
- ORB - OFFICIAL RECORD BOOK
- PUE - PUBLIC UTILITY EASEMENT
- PB - PLAT BOOK
- PG - PAGE

SHEET 11 OF 14



CAULFIELD & WHEELER, INC.
CIVIL ENGINEERING
LANDSCAPE ARCHITECTURE - SURVEYING
7900 GLADES ROAD - SUITE 100
BOCA RATON, FLORIDA 33434
PHONE (561)-392-1991 / FAX (561)-750-1452



DATE	8/5/2020
DRAWN BY	RLF
F.B./ PG.	N/A
SCALE	AS SHOWN
JOB NO.	8993

SG4 MPUD
SKETCH OF DESCRIPTION

SEE SHEET 13

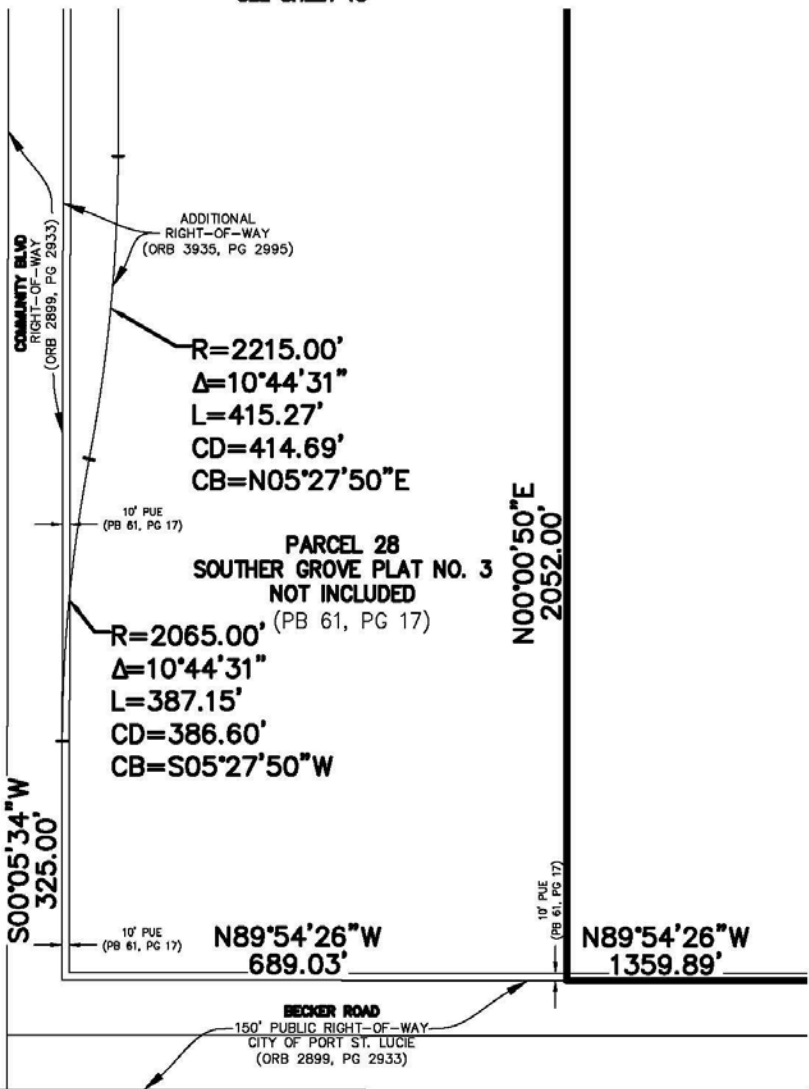
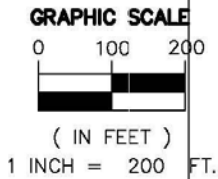

SEE SHEET 11

LEGEND

- D.B. - DEED BOOK
- ORB - OFFICIAL RECORD BOOK
- PUE - PUBLIC UTILITY EASEMENT
- PB - PLAT BOOK
- PG - PAGE

SHEET 12 OF 14



CAULFIELD & WHEELER, INC.
 CIVIL ENGINEERING
 LANDSCAPE ARCHITECTURE - SURVEYING
 7900 GLADES ROAD - SUITE 100
 BOCA RATON, FLORIDA 33434
 PHONE (561)-392-1991 / FAX (561)-750-1452

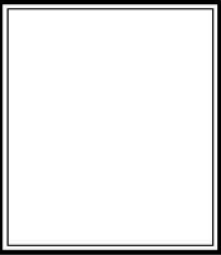

DATE	8/5/2020
DRAWN BY	RLF
F.B./ PG.	N/A
SCALE	AS SHOWN
JOB NO.	8993

SG4 MPUD
SKETCH OF DESCRIPTION

SEE SHEET 3

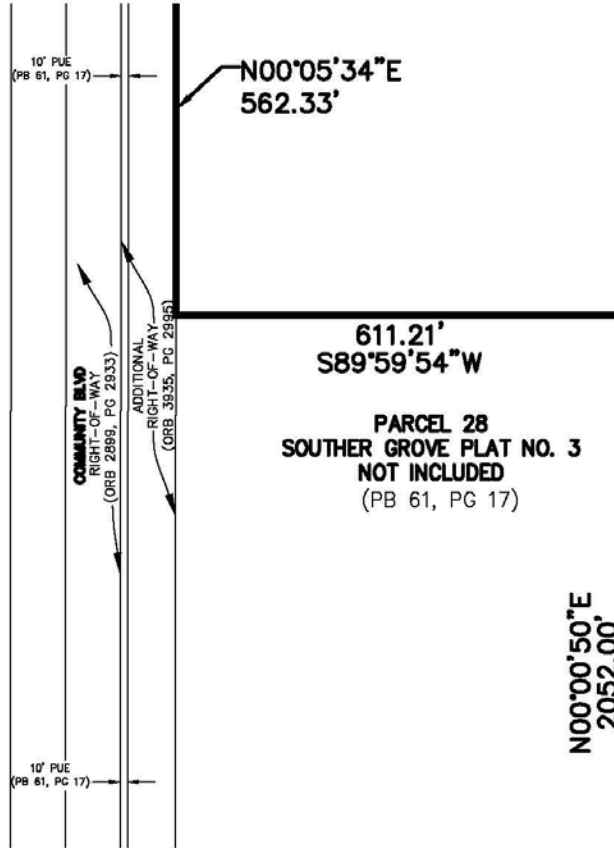

SEE SHEET 12



GRAPHIC SCALE

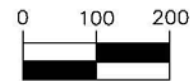

(IN FEET)

1 INCH = 200 FT.

LEGEND

- D.B. - DEED BOOK
- ORB - OFFICIAL RECORD BOOK
- PUE - PUBLIC UTILITY EASEMENT
- PB - PLAT BOOK
- PG - PAGE

SHEET 13 OF 14

CAULFIELD & WHEELER, INC.
 CIVIL ENGINEERING
 LANDSCAPE ARCHITECTURE - SURVEYING
 7900 GLADES ROAD - SUITE 100
 BOCA RATON, FLORIDA 33434
 PHONE (561)-392-1991 / FAX (561)-750-1452

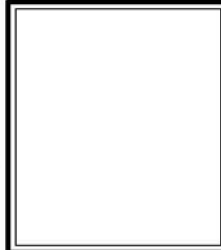

DATE	8/5/2020
DRAWN BY	RLF
F.B./ PG.	N/A
SCALE	AS SHOWN
JOB NO.	8993

**SG4 MPUD
SKETCH OF DESCRIPTION**

EXHIBIT 7 (proposed additional land area)

LEGAL DESCRIPTION:

A PORTION OF KENLEY ACCORDING TO THE PLAT THEREOF, AS RECORDED IN PLAT BOOK 104, PAGE 16, PUBLIC RECORDS OF ST. LUCIE COUNTY, FLORIDA, AND MORE PARTICULARLY DESCRIBED AS FOLLOWS:

BEGINNING AT THE SOUTHWEST CORNER OF THE PLAT OF THE ABOVE MENTIONED KENLEY, THENCE, NORTH 00°05'34" WEST, A DISTANCE OF 325.00 FEET TO THE BEGINNING OF A CURVE TO THE RIGHT THROUGH AN ANGLE OF 10° 44' 31", FOR AN ARC LENGTH OF 387.15 FEET, HAVING A RADIUS OF 2065.00 FEET, AND WHOSE CHORD BEARS NORTH 05° 27' 50" EAST FOR A DISTANCE OF 388.60 FEET TO THE BEGINNING OF A CURVE TO THE LEFT THROUGH AN ANGLE OF 10° 44' 31". FOR AN ARC LENGTH OF 415.27 FEET, HAVING A RADIUS OF 2215.00 FEET, AND WHOSE CHORD BEARS NORTH 05° 27' 50" EAST FOR A DISTANCE OF 414.69 FEET; THENCE, NORTH 00°05'34" EAST, A DISTANCE OF 929.35 FEET; THENCE, SOUTH 89°54'26" EAST, A DISTANCE OF 611.00 FEET; THENCE, SOUTH 00°05'34" WEST, A DISTANCE OF 2052.12 FEET; THENCE, NORTH 89°54'26" WEST, A DISTANCE OF 686.01 FEET TO THE POINT OF BEGINNING.

CONTAINING 30.023 ACRES OF LAND, MORE OR LESS.

SUBJECT TO EASEMENTS, RESTRICTIONS, RESERVATIONS, COVENANTS, AND RIGHTS-OF-WAY OF RECORD.

TOGETHER WITH:

A PORTION OF KENLEY ACCORDING TO THE PLAT THEREOF, AS RECORDED IN PLAT BOOK 104, PAGE 16, PUBLIC RECORDS OF ST. LUCIE COUNTY, FLORIDA, AND MORE PARTICULARLY DESCRIBED AS FOLLOWS:

COMMENCING AT THE SOUTHWEST CORNER OF PARCEL 28-A OF THE PLAT OF SOUTHERN GROVE PLAT NO. 3 ACCORDING TO THE PLAT THEREOF, AS RECORDED IN PLAT BOOK 61, PAGE 17, PUBLIC RECORDS OF ST. LUCIE COUNTY, FLORIDA, THENCE, NORTH 72°19'20" WEST, A DISTANCE OF 202.88 FEET TO THE POINT OF BEGINNING; THENCE, NORTH 72°19'20" WEST, A DISTANCE OF 543.58 FEET; THENCE, NORTH 17°40'40" EAST, A DISTANCE OF 20.00 FEET TO THE BEGINNING OF A NON-TANGENT CURVE TO THE LEFT THROUGH AN ANGLE OF 107° 21' 34", FOR AN ARC LENGTH OF 740.14 FEET, HAVING A RADIUS OF 395.00 FEET, AND WHOSE CHORD BEARS NORTH 53° 59' 53" EAST FOR A DISTANCE OF 636.52 FEET; THENCE, SOUTH 00°19'06" WEST, A DISTANCE OF 558.28 FEET TO THE POINT OF BEGINNING.

CONTAINING 1.765 ACRES OF LAND, MORE OR LESS.

SUBJECT TO EASEMENTS, RESTRICTIONS, RESERVATIONS, COVENANTS, AND RIGHTS-OF-WAY OF RECORD.

SHEET 1 OF 5

PROJECT NO. P22-227

	<p>CAULFIELD & WHEELER, INC. CIVIL ENGINEERING LANDSCAPE ARCHITECTURE - SURVEYING 7900 GLADES ROAD - SUITE 100 BOCA RATON, FLORIDA 33434 PHONE (561)-392-1991 / FAX (561)-750-1452</p>
---	---

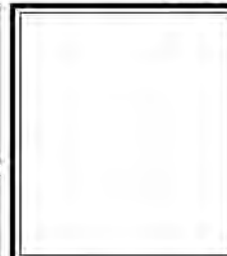

DATE	12/06/2022
DRAWN BY	RLF
F.B. / PG.	N/A
SCALE	AS SHOWN
JOB NO.	8993

**SG4 MPUD
SKETCH OF DESCRIPTION**

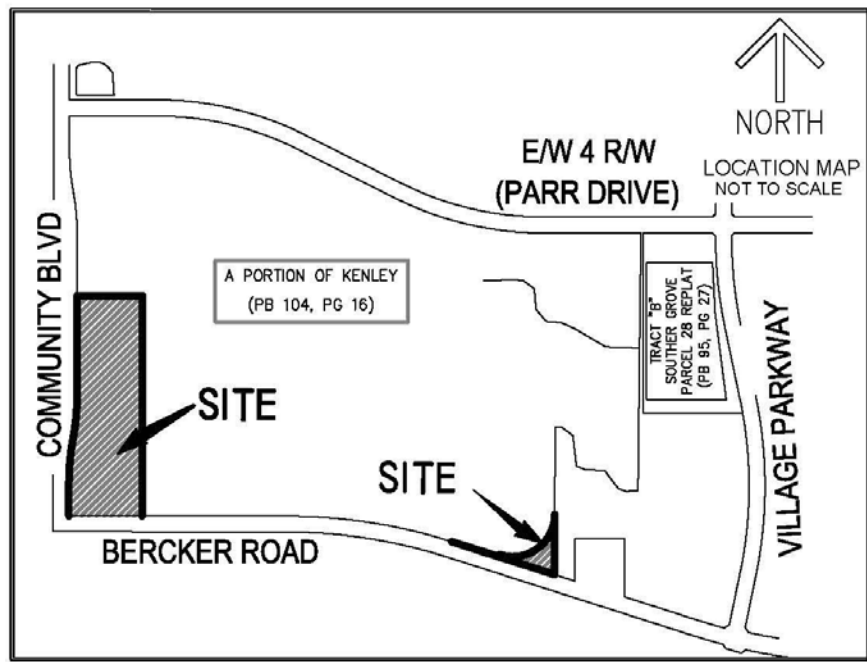

NOTES:

1. REPRODUCTIONS OF THIS SKETCH ARE NOT VALID UNLESS SEALED WITH A SURVEYOR'S SEAL.
2. LANDS SHOWN HEREON ARE NOT ABSTRACTED FOR RIGHTS-OF-WAY, EASEMENTS, OWNERSHIP, OR OTHER INSTRUMENTS OF RECORD.
3. BEARINGS SHOWN HEREON ARE RELATIVE TO A PLAT BEARING OF N89°54'26"W ALONG THE SOUTH LINE OF TRACT A1 KENELY, AS RECORDED IN PLAT BOOK 104, PAGE 16, OF THE PUBLIC RECORDS OF ST. LUCIE COUNTY, FLORIDA.
4. DATA SHOWN HEREON WAS COMPILED FROM INSTRUMENTS OF RECORD AND DOES NOT CONSTITUTE A FIELD SURVEY AS SUCH.

CERTIFICATE:

I HEREBY CERTIFY THAT THE ATTACHED SKETCH OF DESCRIPTION OF THE HEREON DESCRIBED PROPERTY IS TRUE AND CORRECT TO THE BEST OF MY KNOWLEDGE AND BELIEF AS PREPARED UNDER MY DIRECTION ON DECEMBER 6, 2022. I FURTHER CERTIFY THAT THIS SKETCH OF DESCRIPTION MEETS THE STANDARDS OF PRACTICE SET FORTH IN CHAPTER 5J-17 ADOPTED BY THE FLORIDA BOARD OF SURVEYORS AND MAPPERS PURSUANT TO FLORIDA STATUTES 472.027.

SHEET 2 OF 5



CAULFIELD & WHEELER, INC.
 CIVIL ENGINEERING
 LANDSCAPE ARCHITECTURE - SURVEYING
 7900 GLADES ROAD - SUITE 100
 BOCA RATON, FLORIDA 33434
 PHONE (561)-392-1991 / FAX (561)-750-1452

RONNIE L. FURNISS
 PROFESSIONAL SURVEYOR
 AND MAPPER LS6272
 STATE OF FLORIDA
 L.B. 3591

DATE	12/06/2022
DRAWN BY	RLF
F.B./ PG.	N/A
SCALE	AS SHOWN
JOB NO.	8993

**SG4 MPUD
 SKETCH OF DESCRIPTION**

SEE SHEET 4



GRAPHIC SCALE

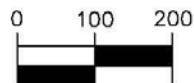

(IN FEET)
1 INCH = 200 FT.

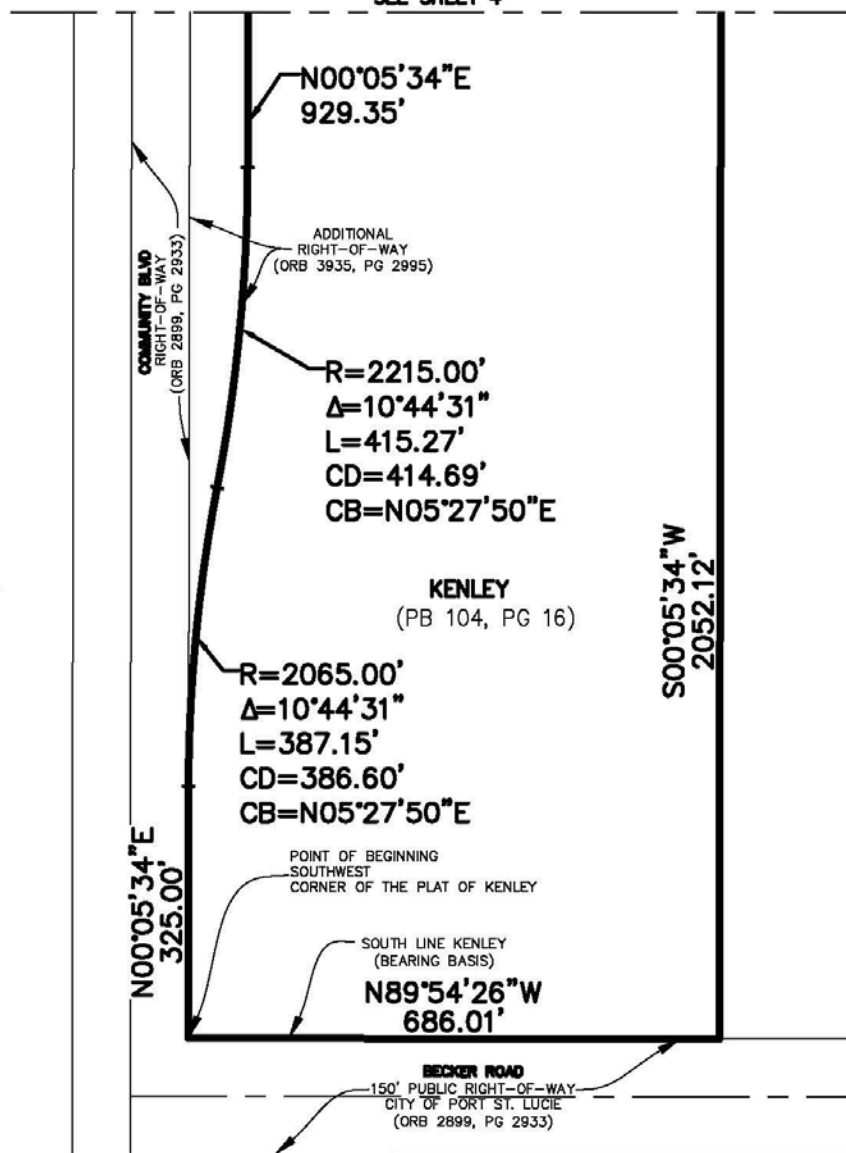

LEGEND

- D.B. - DEED BOOK
- ORB - OFFICIAL RECORD BOOK
- PUE - PUBLIC UTILITY EASEMENT
- PB - PLAT BOOK
- PG - PAGE

SHEET 3 OF 5

CAULFIELD & WHEELER, INC.
 CIVIL ENGINEERING
 LANDSCAPE ARCHITECTURE - SURVEYING
 7900 GLADES ROAD - SUITE 100
 BOCA RATON, FLORIDA 33434
 PHONE (561)-392-1991 / FAX (561)-750-1452

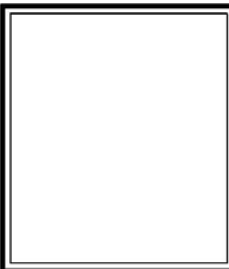

DATE	12/06/2022
DRAWN BY	RLF
F.B./ PG.	N/A
SCALE	AS SHOWN
JOB NO.	8993

**SG4 MPUD
SKETCH OF DESCRIPTION**

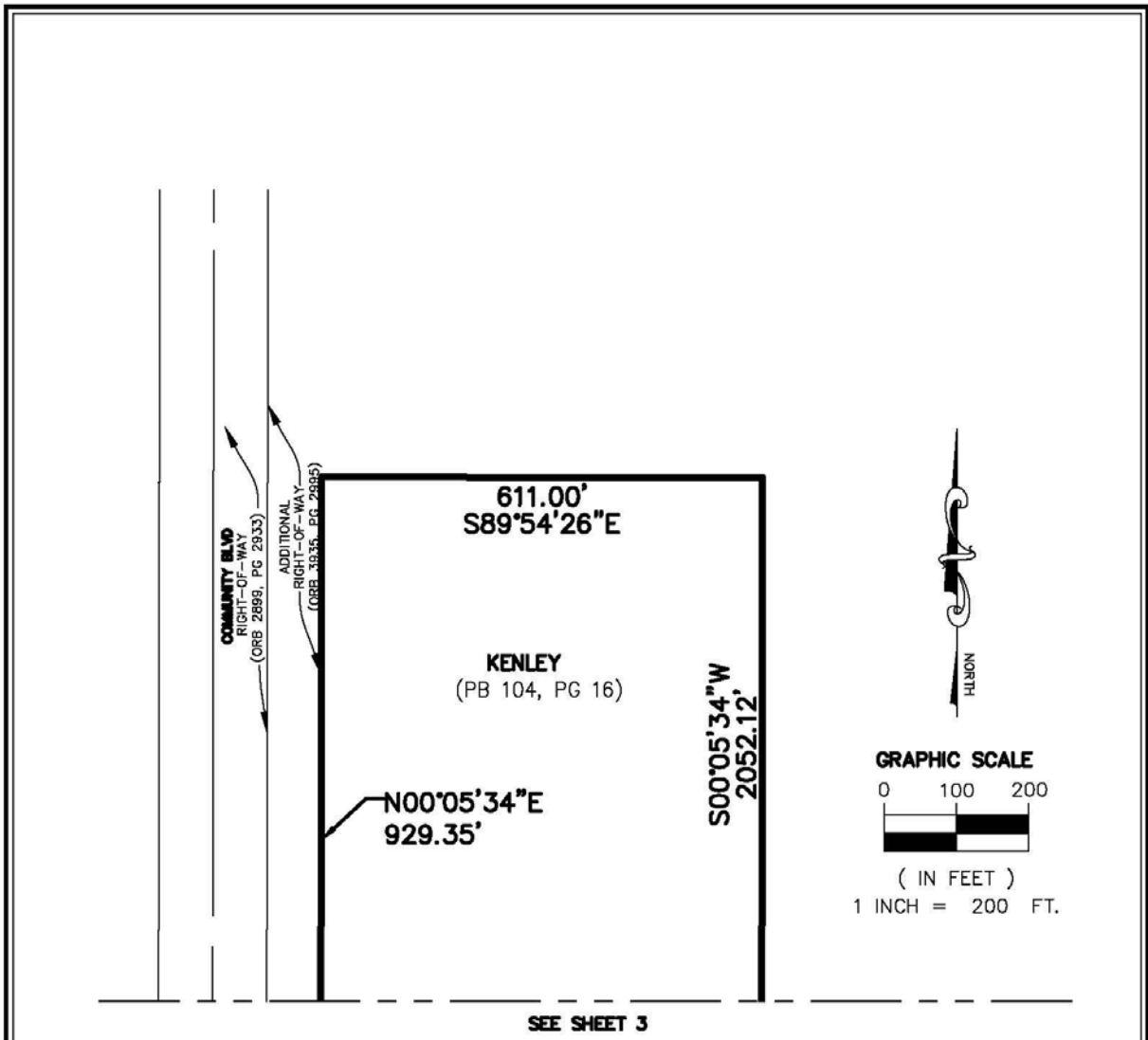

LEGEND

- D.B. - DEED BOOK
- ORB - OFFICIAL RECORD BOOK
- PUE - PUBLIC UTILITY EASEMENT
- PB - PLAT BOOK
- PG - PAGE

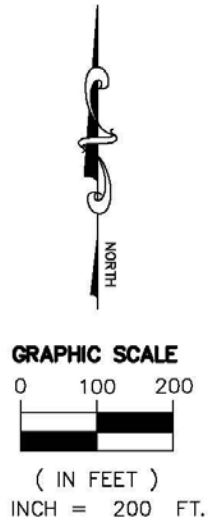

	<p>CAULFIELD & WHEELER, INC. CIVIL ENGINEERING LANDSCAPE ARCHITECTURE - SURVEYING 7900 GLADES ROAD - SUITE 100 BOCA RATON, FLORIDA 33434 PHONE (561)-392-1991 / FAX (561)-750-1452</p>
---	--

**SG4 MPUD
 SKETCH OF DESCRIPTION**

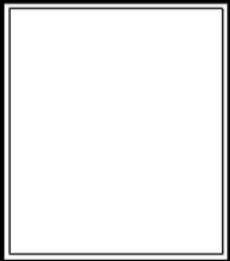

SHEET 4 OF 5

DATE	12/06/2022
DRAWN BY	RLF
F.B./ PG.	N/A
SCALE	AS SHOWN
JOB NO.	8993

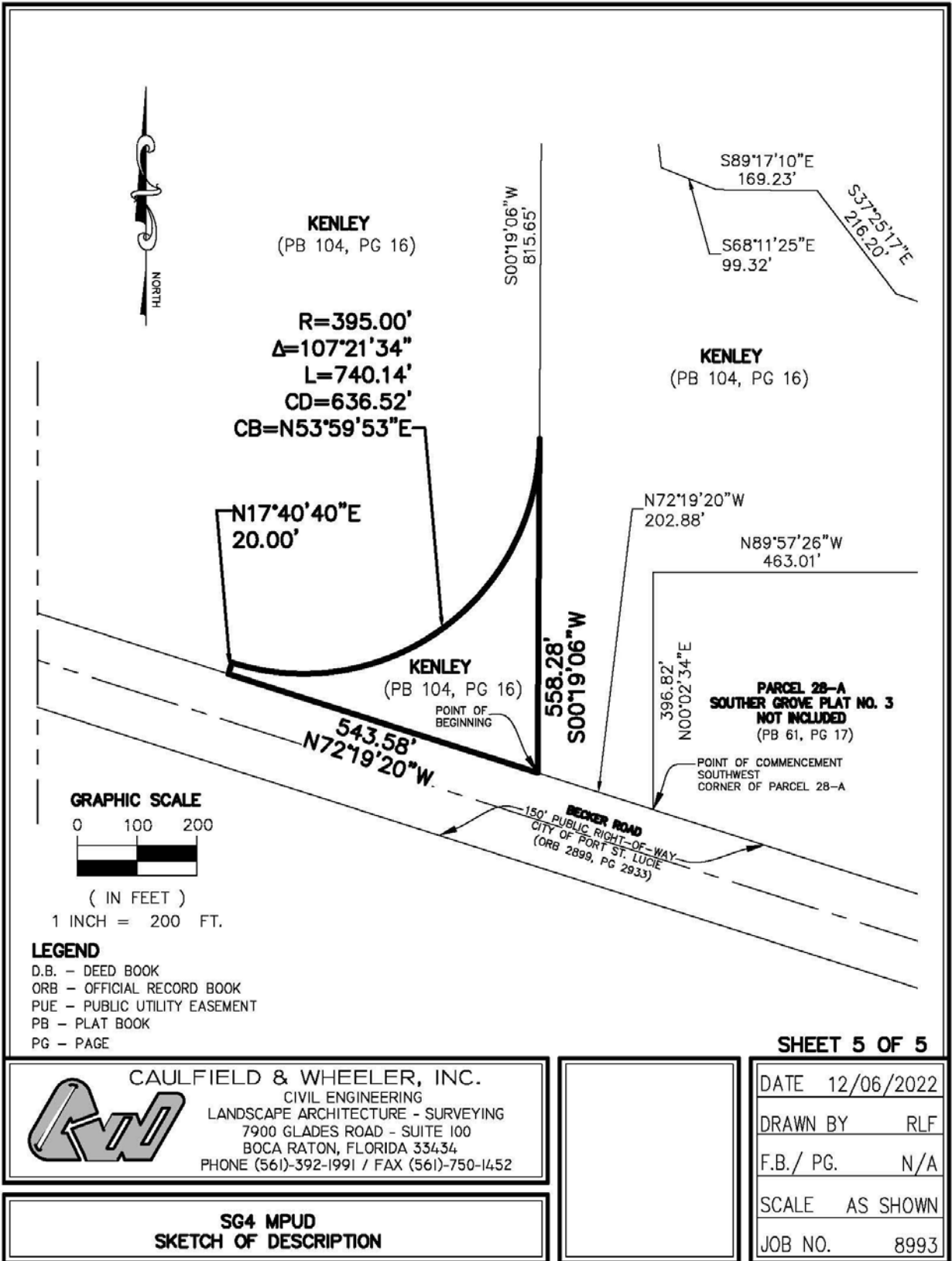
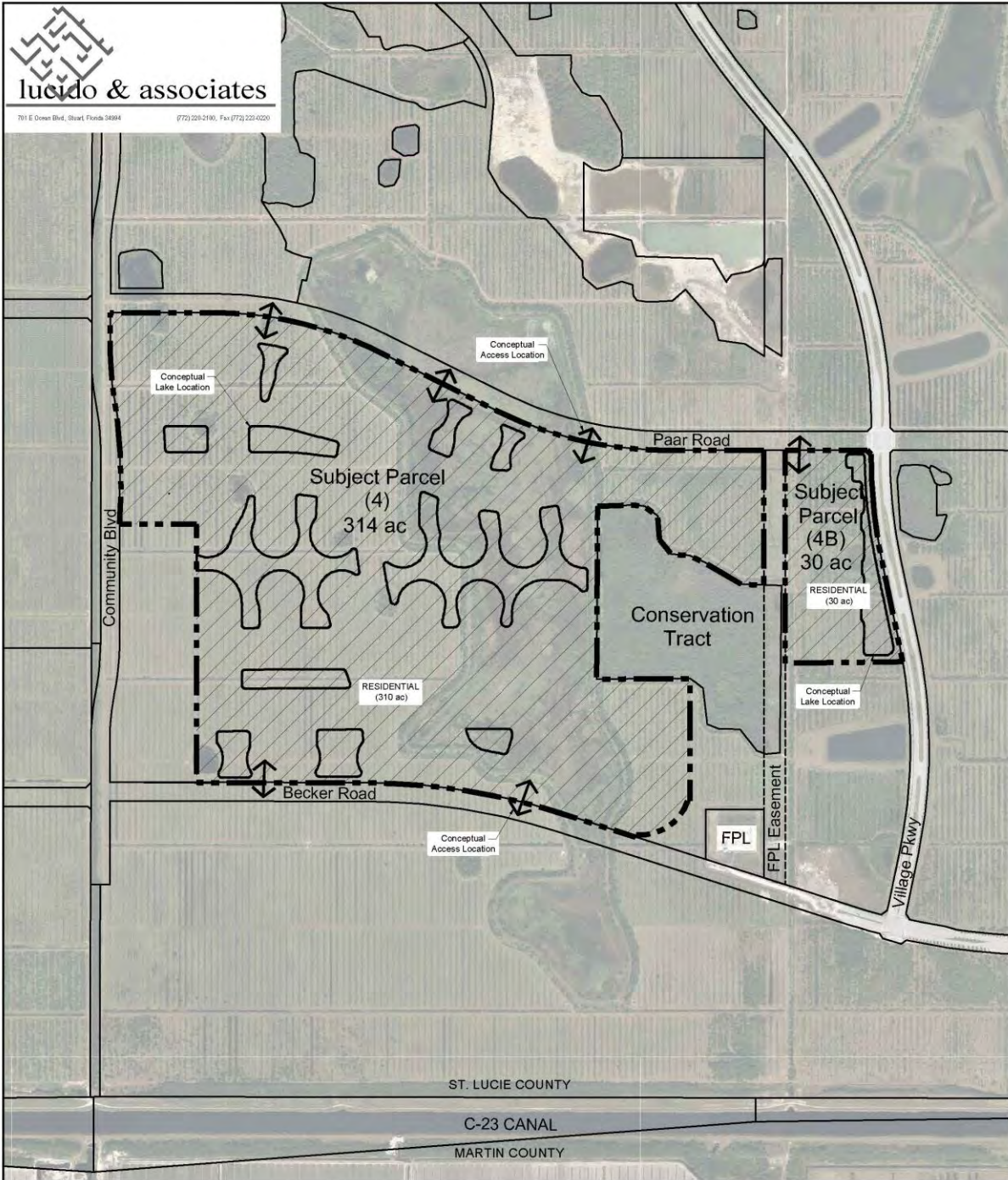

EXHIBIT 8 (existing)

CONCEPTUAL PLAN



lucido & associates
701 E. Ocean Blvd., Stuart, Florida 34984
(772) 220-2180, Fax (772) 222-0220

Computer File
Project Number 20-370
Scale: 1" = NTS



Conceptual Land Use Plan

Port St. Lucie, Florida

EXHIBIT 8 (proposed)

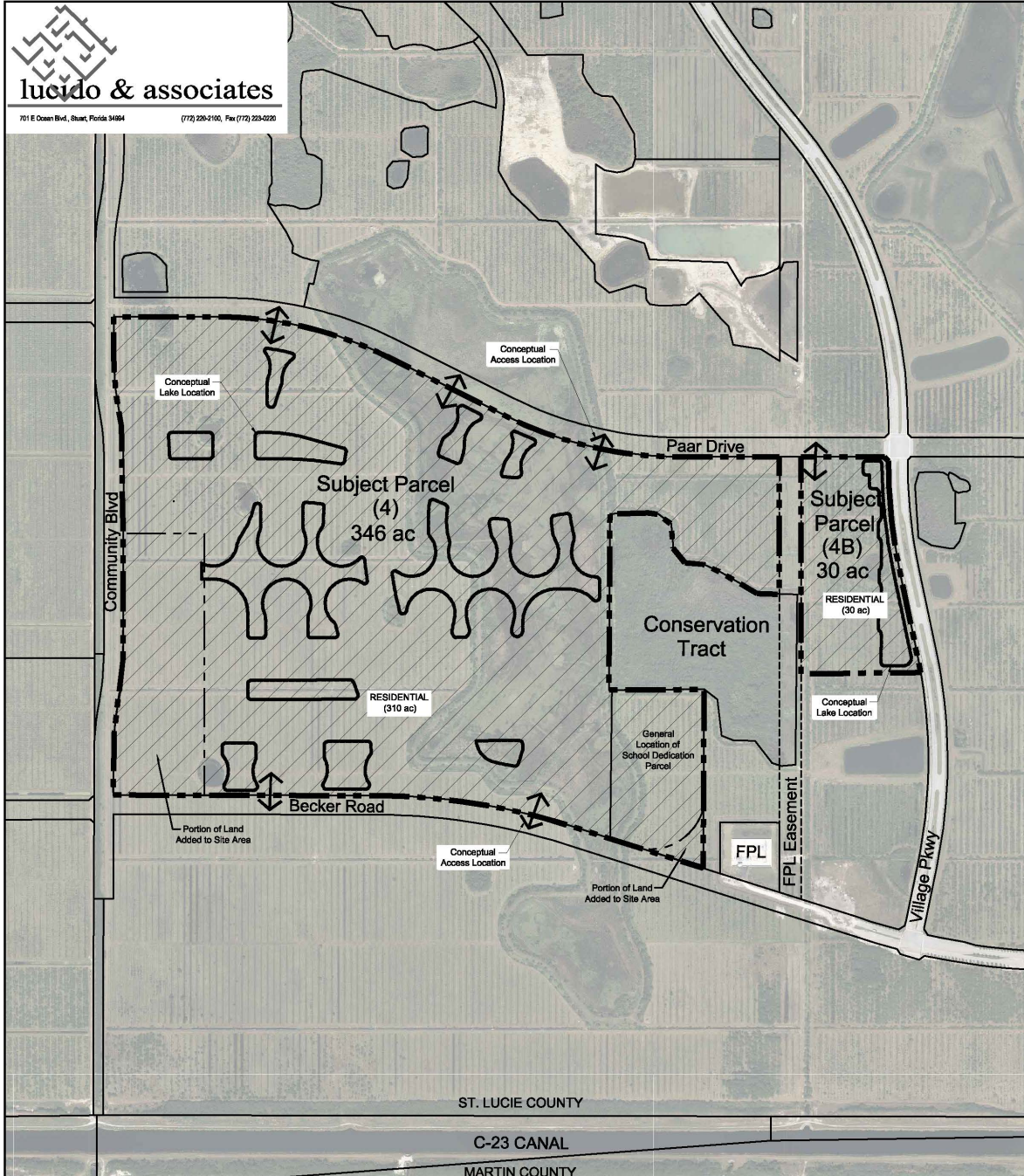

Note: Final arrangement of site-specific elements such as vehicular access locations, lakes, etc. shall be determined at time of site plan development

Computer File P20-111 Zoning and land use exhibits - MPUD.dwg
 Project Number 20-370
 Scale: 1" = NTS



Conceptual Land Use Plan

Port St. Lucie, Florida

EXHIBIT 9

DEVELOPMENT PROGRAM

Development program will consist of at least two distinct residential neighborhoods;
Parcel SG4 and Parcel SG4b a ~~Single Family Subdivision and a Single Family Rental Neighborhood.~~

Parcel SG4 – ~~Single Family Residential Neighborhood~~

Currently envisioned as a residential subdivision with access via Paar Drive and Becker Road. Typical lot details included with this document represent options of lot types that could be developed. Total number of dwelling units shall not exceed 1,000 du's. A portion of this parcel shall also include a school dedication site.

Parcel SG-4b – Multi-Family Horizontal Rental Duplex & Rental Single Family Cottages CAPSTONE

This approximately 30 acre parcel located adjacent to Paar Drive (north) and Village Parkway (east) is planned to accommodate ~~rental single family~~ multi-family horizontal cottages and duplex units.

The project is envisioned architecturally and aesthetically as one and two-story cottage and duplex units, surface and garage parking, centralized pool and pool house amenity, and a strong pedestrian circulation system.

The following exhibits are conceptual and meant only to establish a general sense of the potential product type and aesthetic being planned. Total number of dwelling units shall not exceed 300 du's.

EXHIBIT 10

TYPICAL RESIDENTIAL LOT LAYOUT

SINGLE FAMILY
NOT TO SCALE

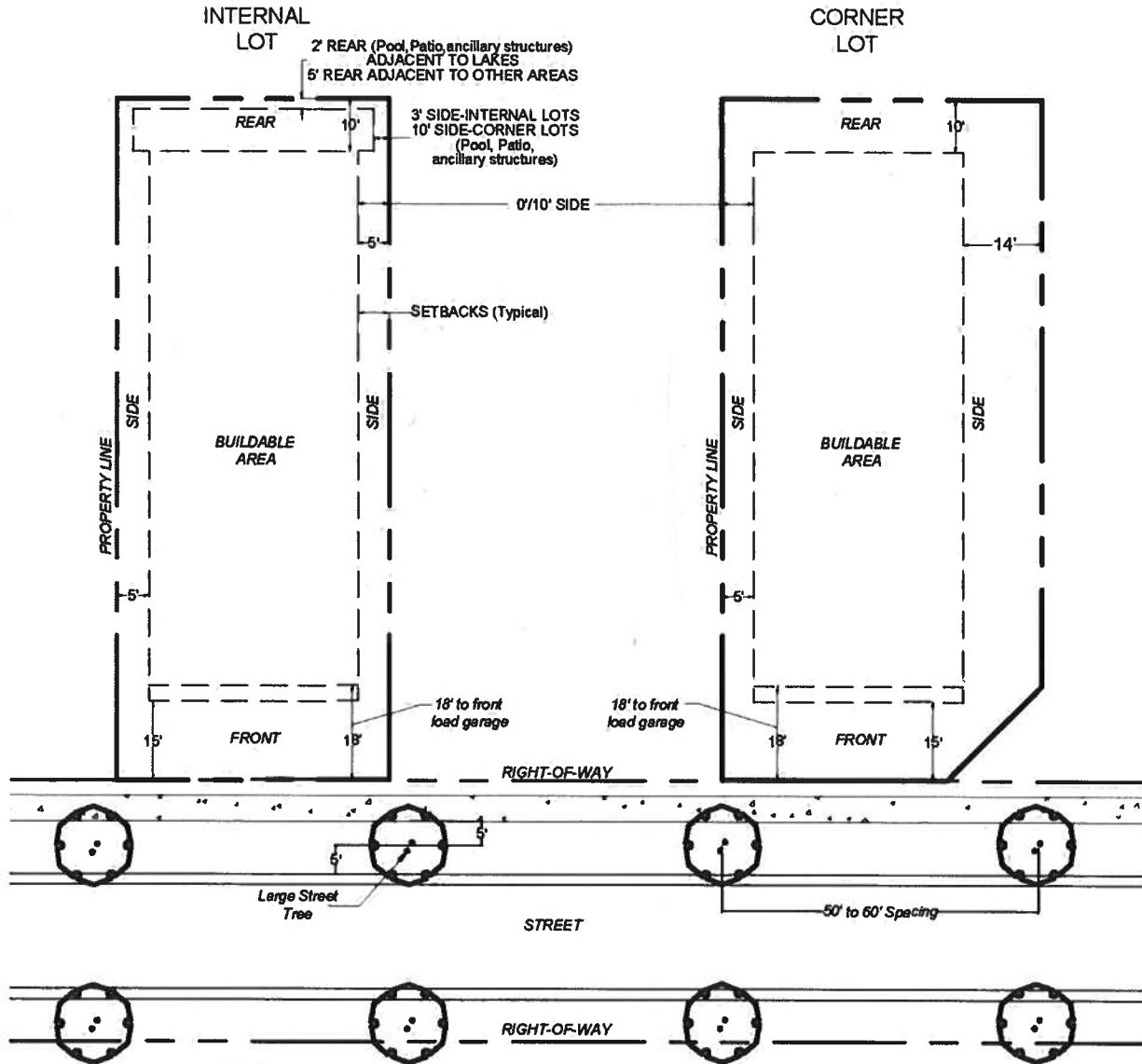

NOTE:

1. BUILDING AREA SHALL BE A MAXIMUM OF 60% OF LOT AREA MAXIMUM IMPERVIOUS SHALL BE 80%.
2. LOT WIDTH MEANS THE HORIZONTAL DISTANCE BETWEEN THE SIDE LOT LINES MEASURED AT RIGHT ANGLES TO THE LOT DEPTH AT A POINT MIDWAY BETWEEN THE FRONT AND REAR PROPERTY LINES.
3. THE MINIMUM FRONT LINE WIDTH AT THE R-O-W LINE SHALL BE 25' FEET
4. STREET TREES WILL MEET FDOT SIGHT LINE AND CLEAR ZONE REQUIREMENTS.

TYPICAL LOT

TOWNHOME LOT - NON ALLEY
NOT TO SCALE

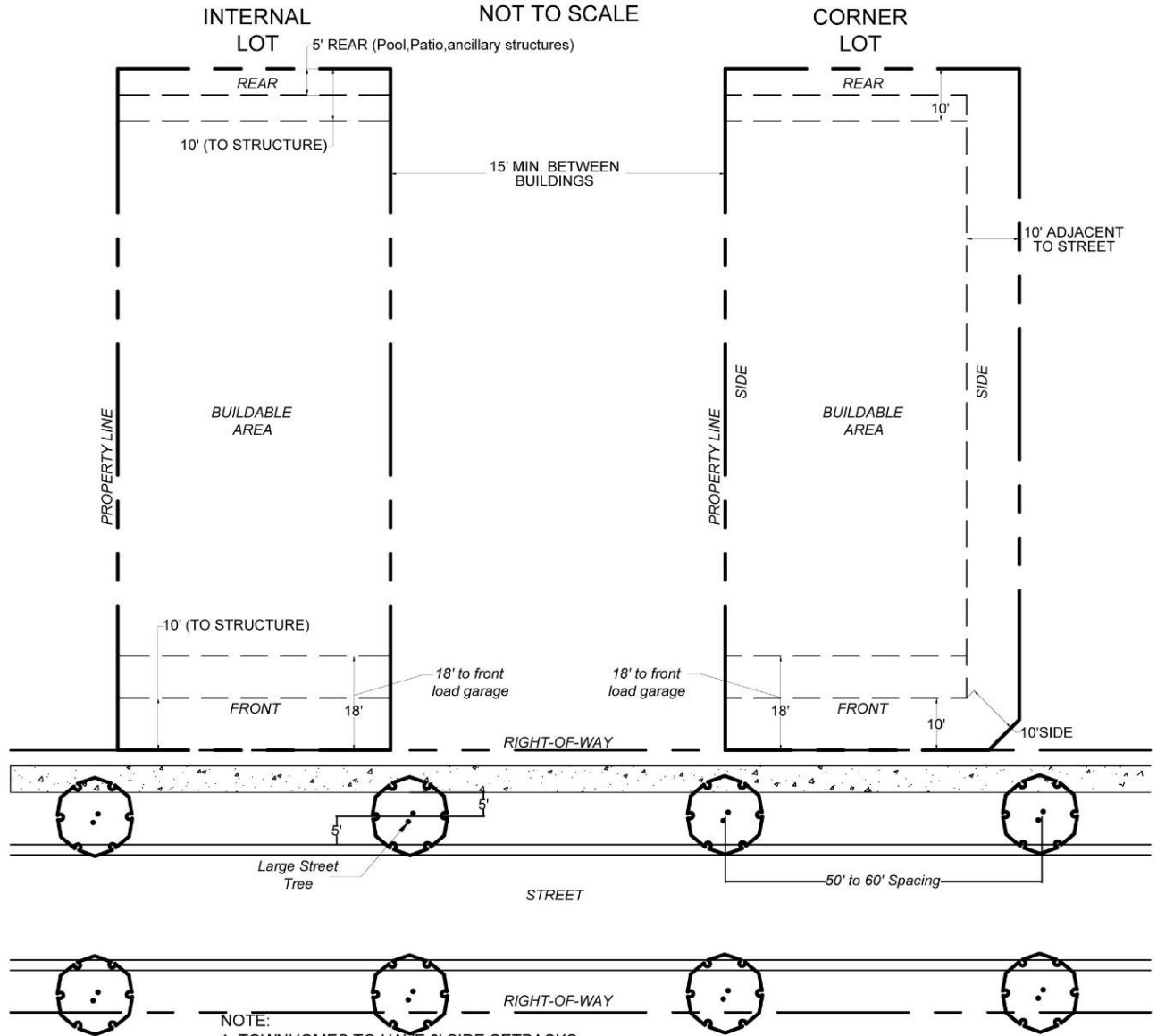

NOTE:

1. TOWNHOMES TO HAVE 0' SIDE SETBACKS.
2. SIDE SETBACKS FOR CORNER LOTS ADJACENT TO A STREET IS 10'.
3. 15' MIN. CLEARANCE SHALL BE PROVIDED BETWEEN BUILDINGS PROVIDED COMPLIANCE WITH ST. LUCIE COUNTY FIRE DISTRICT FIRE PREVENTION CODE RESOLUTION NO. 442-05 ADOPTED SEPTEMBER 21, 2005 IS MET.
4. BUILDING AREA SHALL BE A MAXIMUM OF 60% OF LOT MAXIMUM IMPERVIOUS SHALL BE 80%.
5. LOT WIDTH MEANS THE HORIZONTAL DISTANCE BETWEEN THE SIDE LOT LINES MEASURED AT RIGHT ANGLES TO THE LOT DEPTH AT A POINT MIDWAY BETWEEN THE FRONT AND REAR PROPERTY LINES.
6. STREET TREES WILL MEET FDOT SIGHT LINE AND CLEAR ZONE REQUIREMENTS.

TYPICAL LOT

NON ALLEY LOT

(MIN. 18'-46' WIDTH X MIN. 70' DEPTH)

TOWNHOMES MAY BE DEVELOPED FROM A MIN. OF 3 UNITS TO A MAX OF 8 UNITS, IN A SINGLE BUILDING.

TOWNHOME LOT
NOT TO SCALE

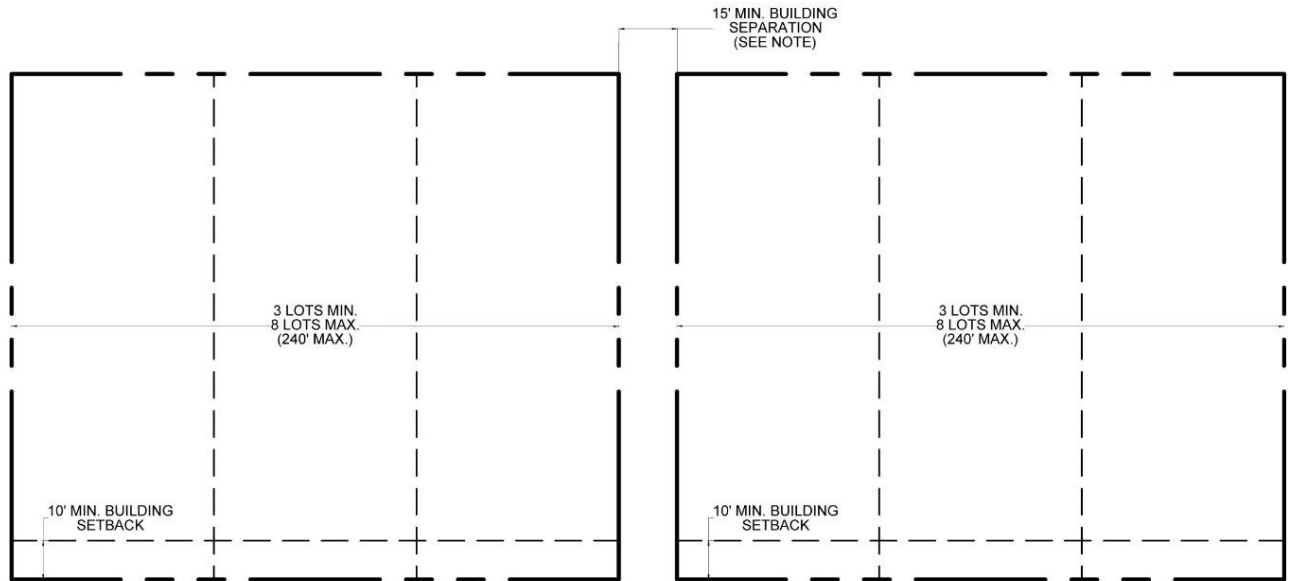

NOTE:

1. 15' MIN. CLEARANCE SHALL BE PROVIDED BETWEEN BUILDINGS PROVIDED COMPLIANCE WITH ST. LUCIE COUNTY FIRE DISTRICT FIRE PREVENTION CODE RESOLUTION NO. 442-05 ADOPTED SEPTEMBER 21, 2005 IS MET.
2. LOT WIDTH MEANS THE HORIZONTAL DISTANCE BETWEEN THE SIDE LOT LINES MEASURED AT RIGHT ANGLES TO THE LOT DEPTH AT A POINT MIDWAY BETWEEN THE FRONT AND REAR PROPERTY LINES.

TYPICAL BUILDING TOWNHOME LAYOUT

PAIRED VILLA AND DUPLEX

Not to Scale

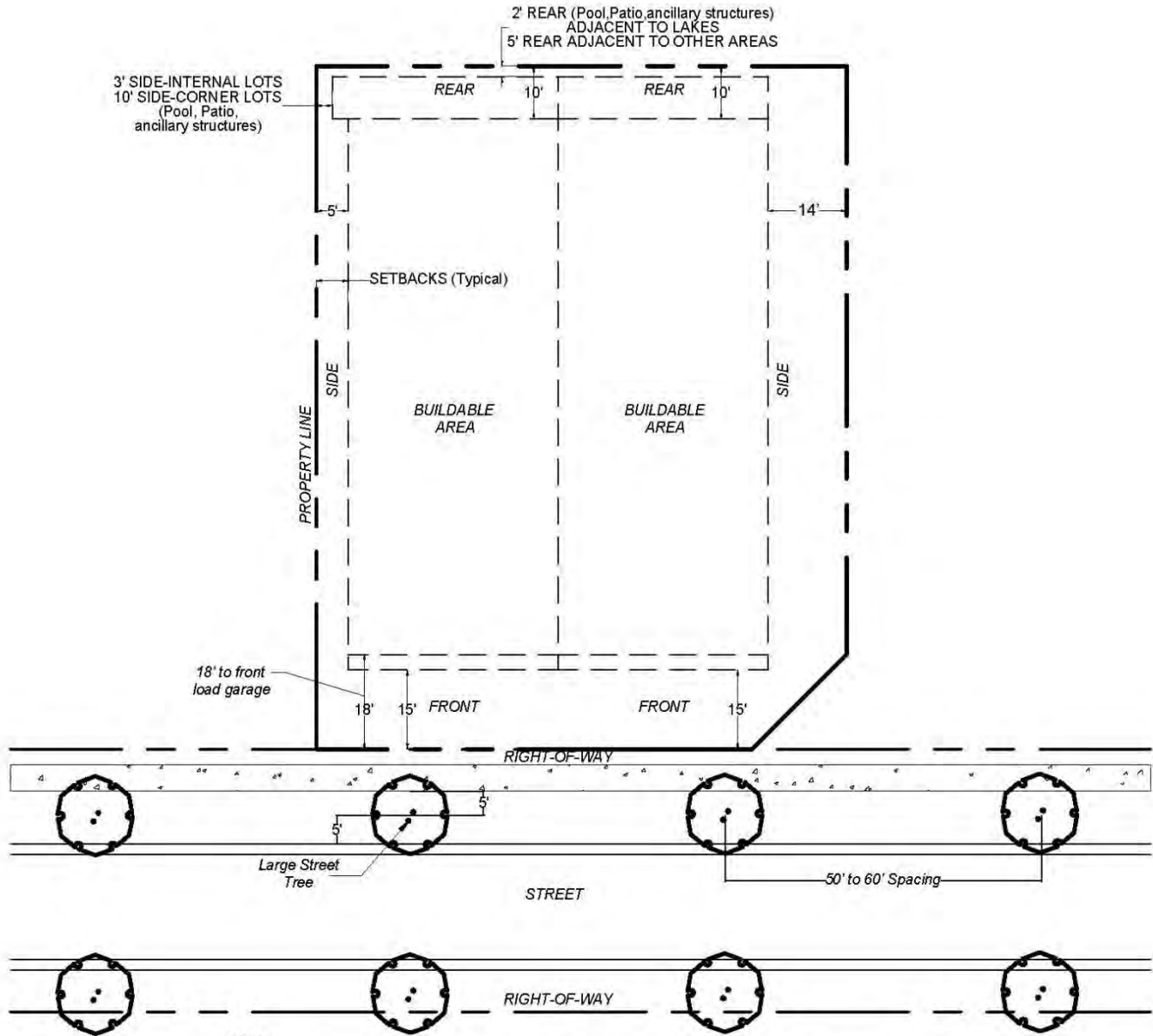

- NOTE:
1. BUILDING AREA SHALL BE A MAXIMUM OF 60% OF LOT AREA MAXIMUM IMPERVIOUS SHALL BE 80%.
 2. LOT WIDTH MEANS THE HORIZONTAL DISTANCE BETWEEN THE SIDE LOT LINES MEASURED AT RIGHT ANGLES TO THE LOT DEPTH AT A POINT MIDWAY BETWEEN THE FRONT AND REAR PROPERTY LINES.
 3. THE MINIMUM FRONT LINE WIDTH AT THE R-O-W LINE SHALL BE 25' FEET
 4. STREET TREES WILL MEET FDOT SIGHT LINE AND CLEAR ZONE REQUIREMENTS.

TYPICAL LOT

MULTIFAMILY RESIDENTIAL
(HORIZONTAL AND VERTICALLY ATTACHED)

Not to Scale

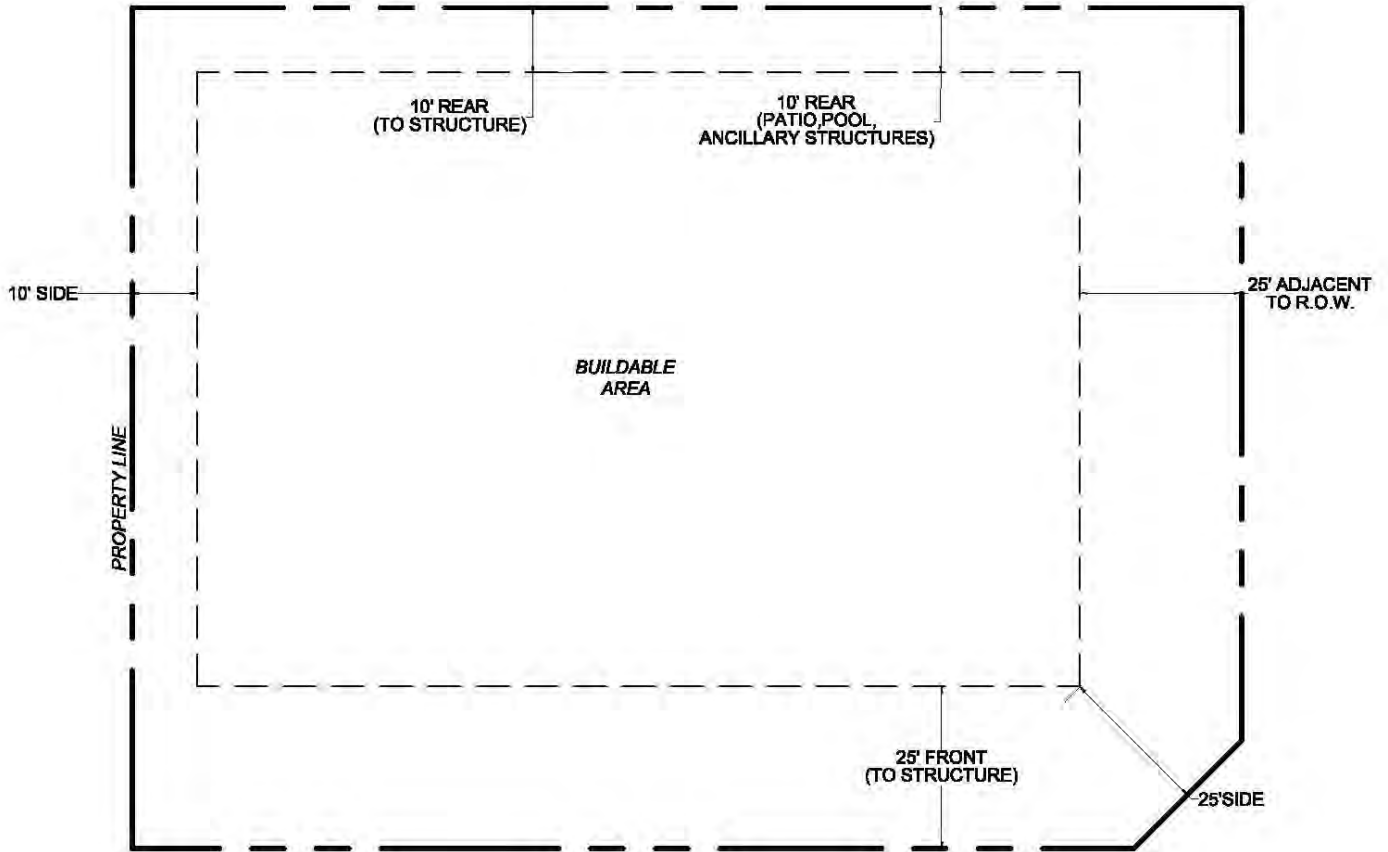

NOTE:

1. SIDE SETBACKS FOR CORNER LOTS ADJACENT TO A STREET IS 25'.
2. 20' MIN. CLEARANCE SHALL BE PROVIDED BETWEEN BUILDINGS PROVIDED COMPLIANCE WITH ST. LUCIE COUNTY FIRE DISTRICT FIRE PREVENTION CODE RESOLUTION NO. 442-05 ADOPTED SEPTEMBER 21, 2005 IS MET.
3. WITHIN THE RESIDENTIAL AREA, BUILDING AREA SHALL BE A MAXIMUM OF 60% OF LOT, MAXIMUM IMPERVIOUS SHALL BE 80%, AND MAXIMUM HEIGHT SHALL BE 65 FT.
4. LOT WIDTH MEANS THE HORIZONTAL DISTANCE BETWEEN THE SIDE LOT LINES MEASURED AT RIGHT ANGLES TO THE LOT DEPTH AT A POINT MIDWAY BETWEEN THE FRONT AND REAR PROPERTY LINES.

EXHIBIT 12

BINDING MPUD AGREEMENT

SOUTHERN GROVE 4 (SG-4)

The property as described on Exhibit 7 Legal Description, is under the unified control of the undersigned petitioner who agrees to (1) proceed with the proposed development according to the provisions of the Port St. Lucie M.P.U.D. Zoning Regulations; and (2) provide such agreements, contracts, deed restriction, and sureties as are acceptable to the City of Port St. Lucie for the completion of the development in accordance with the plan approved by the City. In addition, the said petitioner shall be responsible for the continuing operations and maintenance of such areas, functions, and facilities until such time as a private property owners association, yet to be established, agrees to accept the same responsibilities. Such responsibilities are not to be provided or maintained at public expense. The petitioner further agrees to bind all successors in title to the commitments herein in this paragraph made.

IN WITNESS WHEREOF, we have hereunto set our hands and seals this 2nd day of December, 2022.

WITNESS:

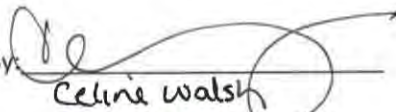
By: 
Celine Walsh

By: 
Tyler Gaffney

MATTAMY PALM BEACH, LLC

Tony Palumbo

BINDING MPUD AGREEMENT

SOUTHERN GROVE 4 (SG-4)

The property as described on Exhibit 7 Legal Description, is under the unified control of the undersigned petitioner who agrees, solely with respect to the portion of the property that it owns, which portion is further described below, to (1) proceed with the proposed development according to the provisions of the Port St. Lucie M.P.U.D. Zoning Regulations; and (2) provide such agreements, contracts, deed restriction, and sureties as are acceptable to the City of Port St. Lucie for the completion of the development in accordance with the plan approved by the City. In addition, the said petitioner shall, solely with respect to the portion of the property that it owns, which portion is further described below, be responsible for the continuing operations and maintenance of such areas, functions, and facilities until such time as a private property owners association, yet to be established, agrees to accept the same responsibilities. Such responsibilities are not to be provided or maintained at public expense. The petitioner further agrees to bind all successors in title to the commitments herein in this paragraph made.

The land referred to herein below is situated in the County of St. Lucie, State of Florida, and described as follows:

Parcel 1:

Tract B, of Southern Grove Parcel 28 Replat, according to the plat thereof, as recorded in Plat Book 95, Page 27, of the Public Records of St. Lucie County, Florida.

Parcel 2:

Non-Exclusive Easement for Storm Water Drainage for the Benefit of Parcel 1, as described in that Certain Drainage Easement recorded June 28, 2018 in Official Records Book 4150, Page 2743, of the Public Records of St. Lucie County, Florida.

IN WITNESS WHEREOF, we have hereunto set our hands and seals this 6th day of December, 2022.

WITNESS:

CCC-PSL LLC

By: Parker Kinzer
Parker Kinzer

By: Patrick Vawter
Patrick Vawter

By: Ben Walker

Name: Ben Walker

Its: Authorized Person

EXHIBIT 13

OWNER AUTHORIZATION

***Mattamy Palm Beach, LLC
1500 Gateway Blvd, Suite 212
Boynton Beach, FL 33426***

Planning & Zoning Department
City of Port St. Lucie
121 S.W. Port St. Lucie Boulevard, Building B
Port St. Lucie, FL 34984-5099

Re: Owner's Authorization - Southern Grove (SG-4)

To Whom It May Concern:

As owner of the property referenced above, please consider this correspondence as formal authorization for LUCIDO & ASSOCIATES to represent Mattamy Palm Beach LLC. as applicant during the governmental review process for the above noted project.

Thank you for your attention to this matter.

Sincerely,



Tony Palumbo, Mattamy Palm Beach, LLC

December 2, 2022

CCC-PSL LLC

Planning & Zoning Department
City of Port St. Lucie
121 S.W. Port St. Lucie Boulevard, Building B
Port St. Lucie, FL 34984-5099

**Re: Owner's Authorization – SG-4 MPUD Amendment
CCC-PSL LLC**

To Whom It May Concern:

As owner of the property described below, please consider this correspondence as formal authorization for LUCIDO & ASSOCIATES to represent CCC-PSL LLC as applicant during the governmental review process for the above noted project.

Thank you for your attention to this matter.

Sincerely,

CCC-PSL LLC



Name: Ben Walker

Title: Authorized Person

Date: 12/06/2022

The land referred to herein below is situated in the County of St. Lucie, State of Florida, and described as follows:

Parcel 1:

Tract B, of Southern Grove Parcel 28 Replat, according to the plat thereof, as recorded in Plat Book 95, Page 27, of the Public Records of St. Lucie County, Florida.

Parcel 2:

Non-Exclusive Easement for Storm Water Drainage for the Benefit of Parcel 1, as described in that Certain Drainage Easement recorded June 28, 2018 in Official Records Book 4150, Page 2743, of the Public Records of St. Lucie County, Florida.