

HKA WAREHOUSE

DEVELOPER : HKA COMMERCIAL, LLC
340 NW ENTERPRISE Dr Ste 101
PORT ST LUCIE, FL 34986

LIST OF CONTACTS

<u>PLANNING & ZONING DEPARTMENT</u> 121 SW Port St. Blvd. Port St. Lucie, FL 34984 (772) 871-5213	<u>PUBLIC WORKS DEPARTMENT</u> 121 SW Port St. Blvd. Port St. Lucie, FL 34984 (772) 871-5177
<u>WATER & SEWER PROVIDER</u> Reserve CDD 2160 Reserve Park Trace Port St. Lucie, FL 34986 (772) 468-4604	<u>BUILDING DEPARTMENT</u> 121 SW Port St. Blvd. Port St. Lucie, FL 34984 (772) 871-5136

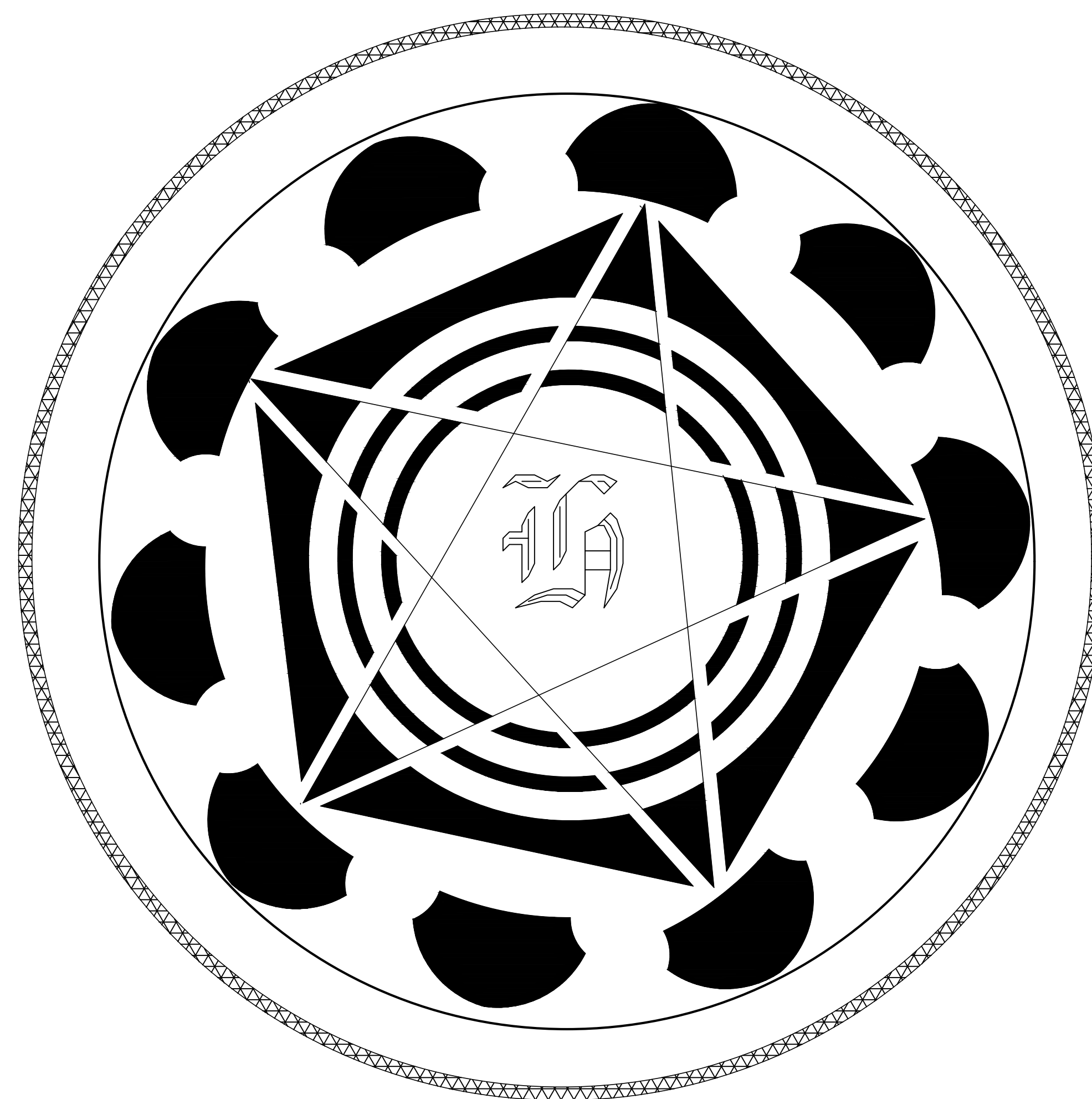

INDEX SHEET

SHEET DESCRIPTION	SHEET Nb
SITE PLAN	1 OF 2
SITE PLAN DETAILS	2 OF 2

LOCATION MAP

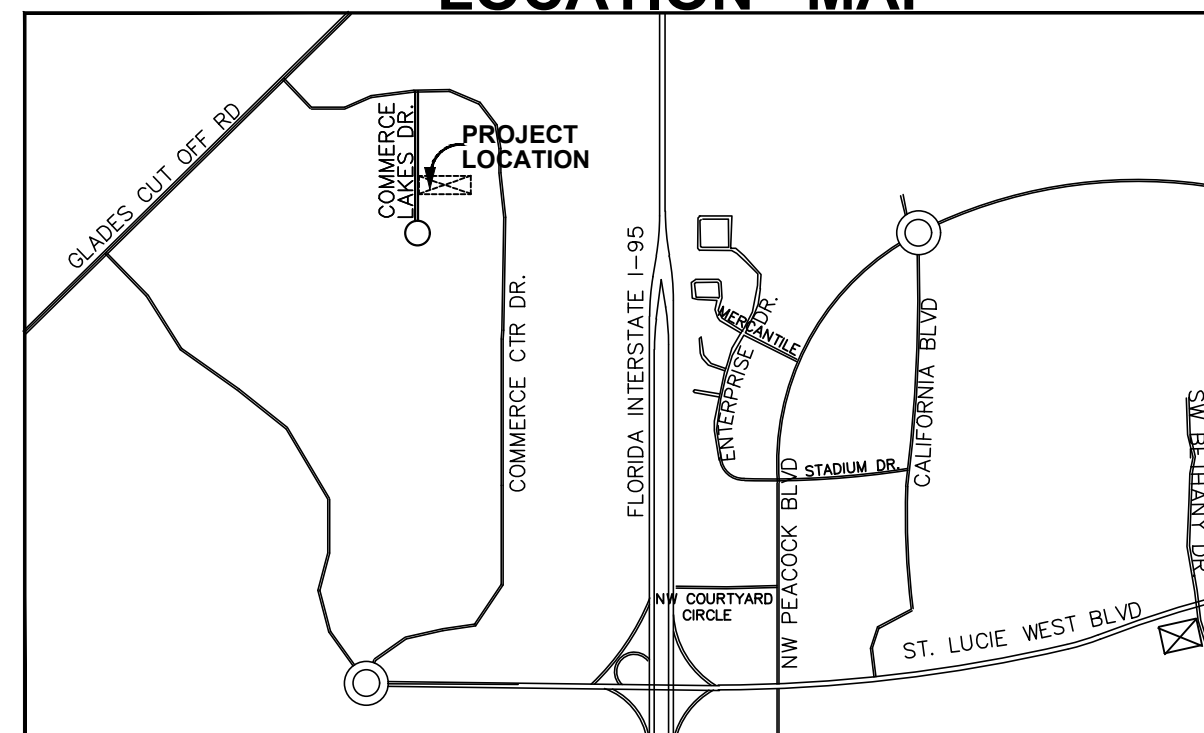

This item has been digitally signed & sealed by **Abraham Chabab, PE**

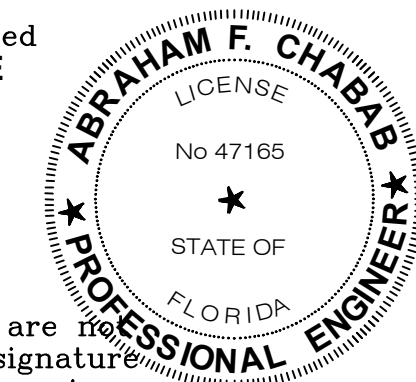

Printed copies of this document are not considered signed & sealed & the signature must be verified on any electronic copies

CITY OF PORT ST. LUCIE
PROJECT NO. P24-074

48 HOURS BEFORE DIGGING
 CALL TOLL-FREE
1-800-432-4770
 SUNSHINE STATE ONE CALL
 OF FLORIDA, INC
 UNDERGROUND UTILITIES NOTIFICATION CENTER

ABRAHAM CHABAB, Inc.
 FL. BOARD OF PROF. ENG. AUTH.#26790
 5019 NW RUGBY DRIVE
 PORT ST. LUCIE FL. 34983
 Email agchabab1@msn.com
 Ph:(772)475-6630

REVISIONS	DATE
Staff Cmts	8.6.24

GENERAL NOTES

PROJECT NAME : HKA WAREHOUSE
 OWNER : HKA COMMERCIAL, LLC
 340 NW ENTERPRISE Dr Ste 101
 PORT ST LUCIE, FL 34986
 LOCATION : 2095 COMMERCE LAKES DR
 LAND USE : CS
 LAND ZONING : IN
 LEGAL DESCRIPTION : LOT 20, BLOCK B, OF G.O. TEAM INDUSTRIAL PARK UNIT THREE ACCORDING TO THE PLAT THEREOF, AS RECORDED IN PLAT BOOK 26, PAGES 2 & 2A OF THE PUBLIC RECORDS OF ST. LUCIE COUNTY, FL. SAID LAND CONTAINS 2.278 ACRES, MORE OR LESS.
 PIN : 331570300090007
 BUILDING HEIGHT : 20.20 FEET
 NUMBER OF STORIES : ONE
 UTILITIES:
 ELECTRICAL : FPL
 WATER & SEWER : RESERVE CDD
 TELEPHONE : ATT
 SOLID WASTE : AUTHORIZED SOLIDWASTE CO.

FLOOD ZONE MAP:

PROPERTY LIES IN F.I.R.M. ZONE X AS SHOWN ON PANEL 12111C0260J (2-16-2012)

DRAINAGE STATEMENT:

PROPOSED STORMWATER DRAINAGE SYSTEM WILL COMPLY WITH SFWMD & CITY OF PORT ST. LUCIE DRAINAGE REQUIREMENTS AS WELL AS RESERVE COMMERCE PARK DRAINAGE SYSTEM.

HAZARDOUS WASTE STATEMENT:

ANY & ALL HAZARDOUS OR TOXIC MATERIALS GENERATED OR USED OR STORED ON SITE SHALL BE DISPOSED OF IN ACCORDANCE WITH ALL LOCAL, STATE AND FEDERAL REGULATIONS

ENVIRONMENTAL STATEMENT:

PROJECT WILL MEET AND COMPLY WITH STATE AND LOCAL REQUIREMENTS & REGULATIONS REGARDING NATIVE HABITATS & VEGETATION.

APPLICATION FEE STATEMENT:

THE APPLICATION IS NOT VESTED FOR ANY MUNICIPAL FEES. ALL FEES ARE CALCULATED AT TIME OF PAYMENT. THIS INCLUDES SPECIFICALLY IMPACT FEES, UPLAND PRESERVE FEES AND ANY ADMINISTRATIVE REVIEW FEES FOR CITY DEPARTMENTS.

TRAFFIC STATEMENT:

AVERAGE TRIPS PER DAY : 77 TRIPS/DAY
 AM PEAK HOUR TRIPS : 32 TRIPS/HR
 PM PEAK HOUR TRIPS : 25 TRIPS/HR
 FROM ITE (INSTITUTE OF TRANSPORTATION ENGINEERS)
 WAREHOUSE/SMALL OFFICE, CODE 150 & 712, ITE MANUAL 11th Edition

AREA TABULATION:

SITE COVERAGE	ACREAGE	SF	% OF SITE
OFFICE AREAS	0.0826	3,600	3.63
WAREHOUSE AREAS	0.4604	20,054	20.21
BUILDING TOTAL	0.5430	23,654	23.84
PROP. PAVED AREA	0.8553	37,257	37.55
PROP. SIDEWALKS/PADS	0.0946	4,120	4.15
PAVEMENT IMPERVIOUS	0.9499	41,377	41.70
TOTAL IMPERVIOUS	1.4929	65,031	65.54
LAKE AREA	0.2067	9,005	9.07
PRESERVE AREA	0.1310	5,706	5.75
GREEN AREA/OPEN SPACE	0.4474	19,488	19.64
TOTAL	2.2780	99,230	100.00

REQUIRED PRESERVE AREA : (2.28- Lake 0.2)x 25%
 (2.28- 0.2)x 25%=0.52 Acres
 0.13 Acres Provided on Site, 0.39 Acres will be Mitigated

PARKING CALCULATIONS:

PARKING SPACES REQUIRED :
 OFFICE AREAS : 3,600SFx1 PKG SPACE/200 SF= 18 PKG SPACES
 WAREHOUSE AREAS : 20,054SFx1 PKG SPACE/500 SF= 40 PKG SPACES
 TOTAL REQUIRED = 58 PKG SPACES
 PARKING PROVIDED : 57 REGULAR PKG & 4 H.C.= 61 PKG SPACES

BUILDING SETBACKS:

	BUILDING 1	BUILDING 2	REQUIRED
FRONT	62.00 FT	62.00 FT	25.00 FT
REAR	137.03 FT	137.03 FT	25.00 FT
LEFT SIDE	11.50 FT	153.10 FT	10.00 FT
RIGHT SIDE	152.00 FT	10.40 FT	10.00 FT

LEGEND

- Runoff Flow Direction
- W.M. = EXIST. WATER MAIN
- G.S. = EXIST. GRAVITY SEWER
- Backflow Preventer
- Water Meter Box
- Fire Hydrant
- Foot Mitered End Section
- Catch Basin
- Proposed Pavement

LAKE AREA
 LAND USE: OSR/CS
 ZONING : CS/OSC

REPORT PREPARED BY
 PATRICK ZULOAGA
 Permit# GTA-13-00002D
 Found no Endangered
 Species on Site

This item has been digitally signed & sealed by Abraham Chabab, PE

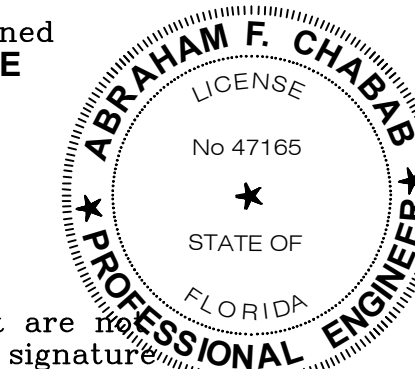

Printed copies of this document are not considered signed & sealed & the signature must be verified on any electronic copies

CITY OF PORT ST. LUCIE
 PROJECT NO. P24-074

DESIGNED BY	AC	REVISIONS	DATE
DRAWN BY	AC		
DATE	Apr. 15/2024		
SHEET	1 OF 2		

MAINTENANCE AND CLEANING STATEMENT:

THE PROPERTY OWNER, CONTRACTOR, AND AUTHORIZED REPRESENTATIVES SHALL PROVIDE PICK UP, REMOVAL AND DISPOSAL OF LITTER WITHIN THE PROJECT LIMITS AND SHALL BE RESPONSIBLE FOR MAINTENANCE OF THE AREA FROM THE EDGE OF PAVEMENT TO THE PROPERTY LINE WITHIN CITY'S RIGHT-OF-WAY IN ACCORDANCE WITH CITY CODE SECTION 41.08(g)

48 HOURS BEFORE DIGGING
 CALL TOLL-FREE
1-800-432-4770
 SUNSHINE STATE ONE CALL
 OF FLORIDA, INC
 UNDERGROUND UTILITIES NOTIFICATION CENTER

ABRAHAM CHABAB, Inc.
 FL. BOARD OF PROF. ENG. AUTH.#26790
 5019 NW RUGBY DRIVE
 PORT ST. LUCIE FL. 34983
 Email agchabab1@msn.com
 Ph:(772)475-6630

HKA WAREHOUSE
SITE PLAN

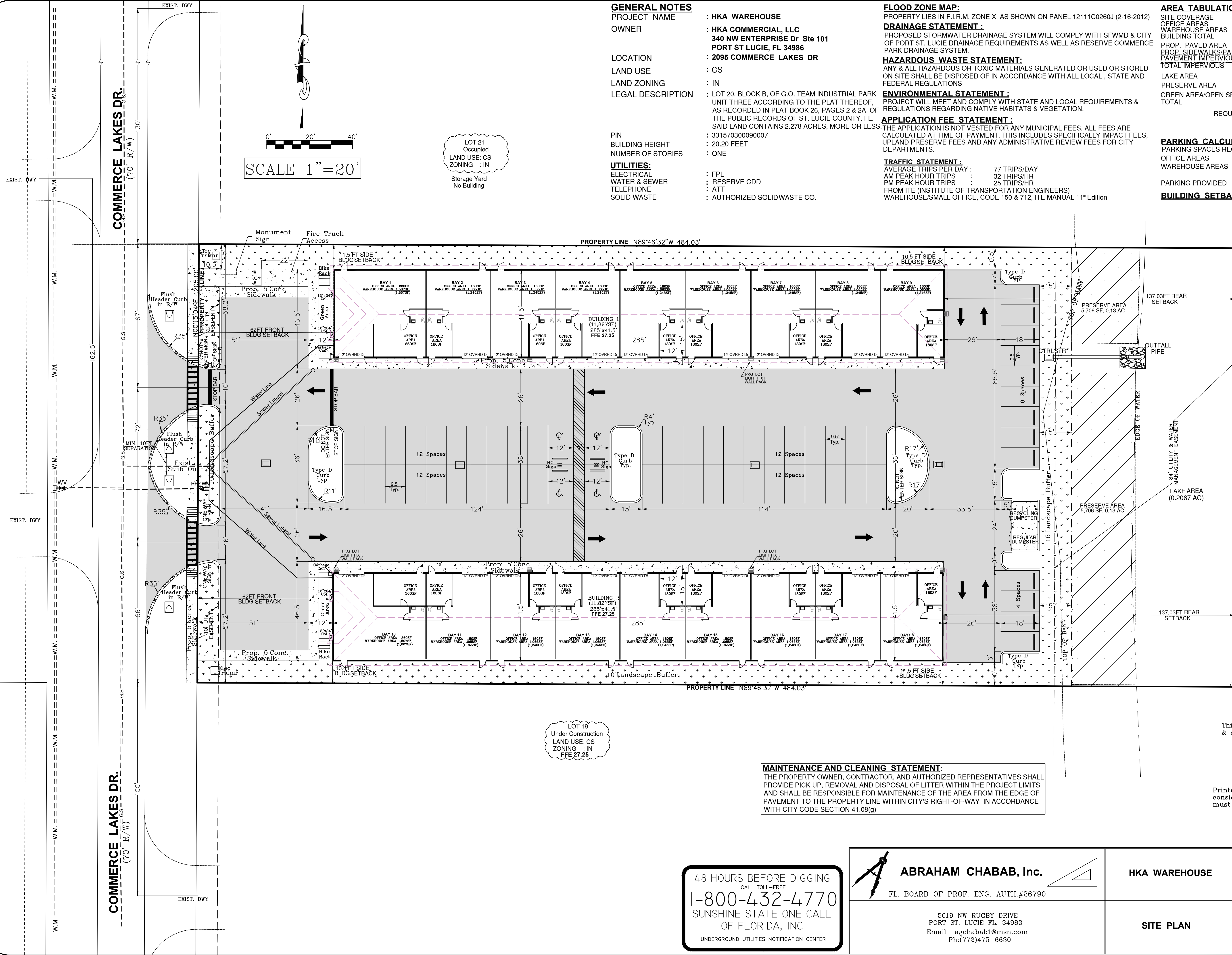

SCALE 1"=20'

LOT 21
 Occupied
 LAND USE: CS
 ZONING : IN
 Storage Yard
 No Building

LOT 19
 Under Construction
 LAND USE: CS
 ZONING : IN
 FFE 27.25

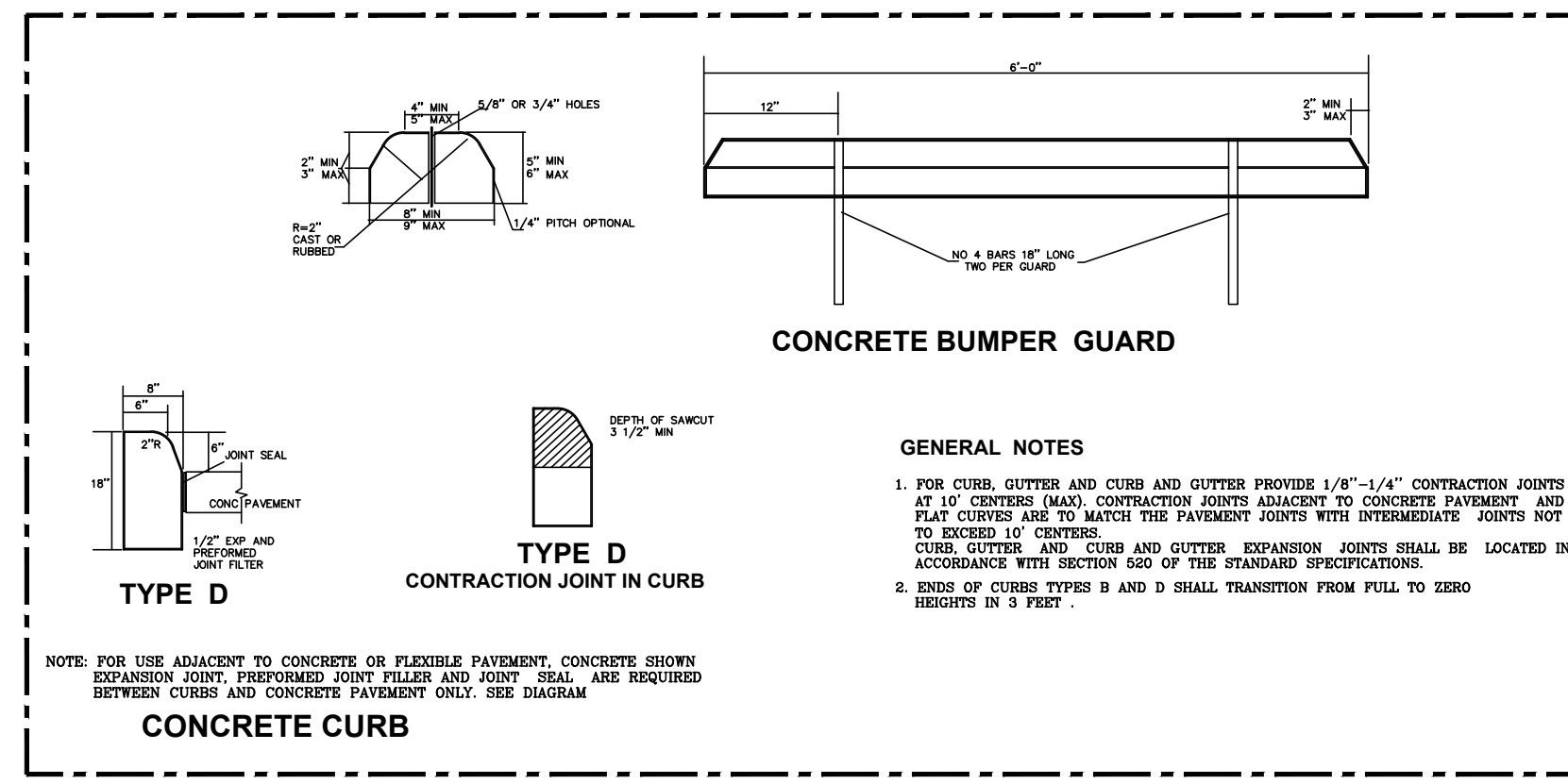

CURB DETAIL
N.T.S.

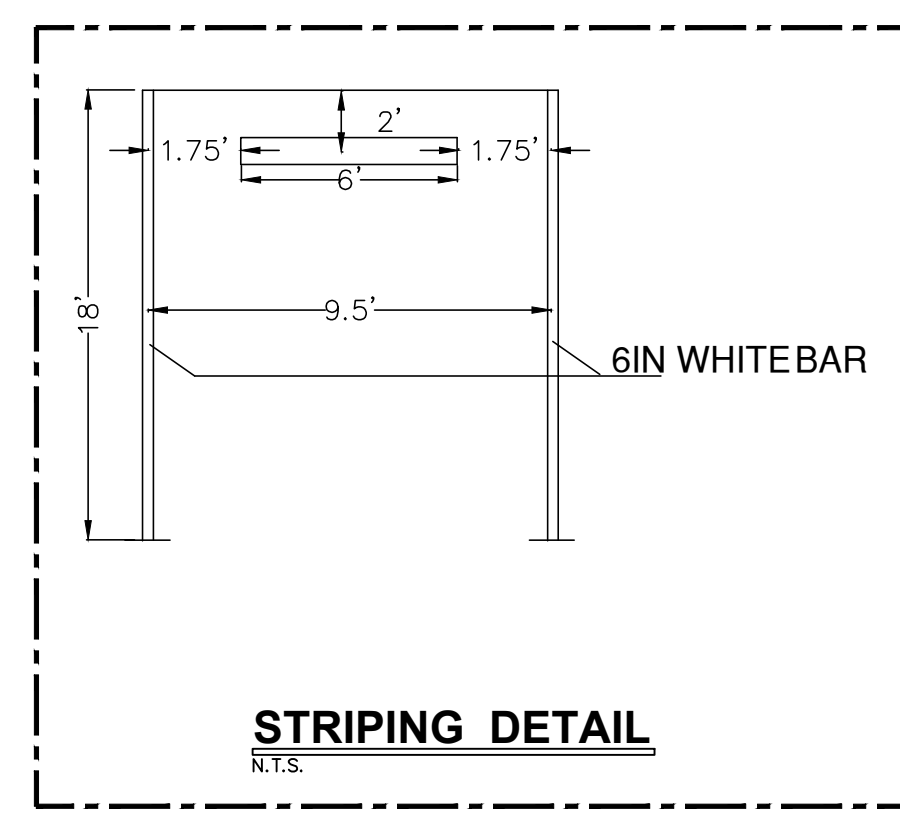

STRIPING DETAIL
N.T.S.

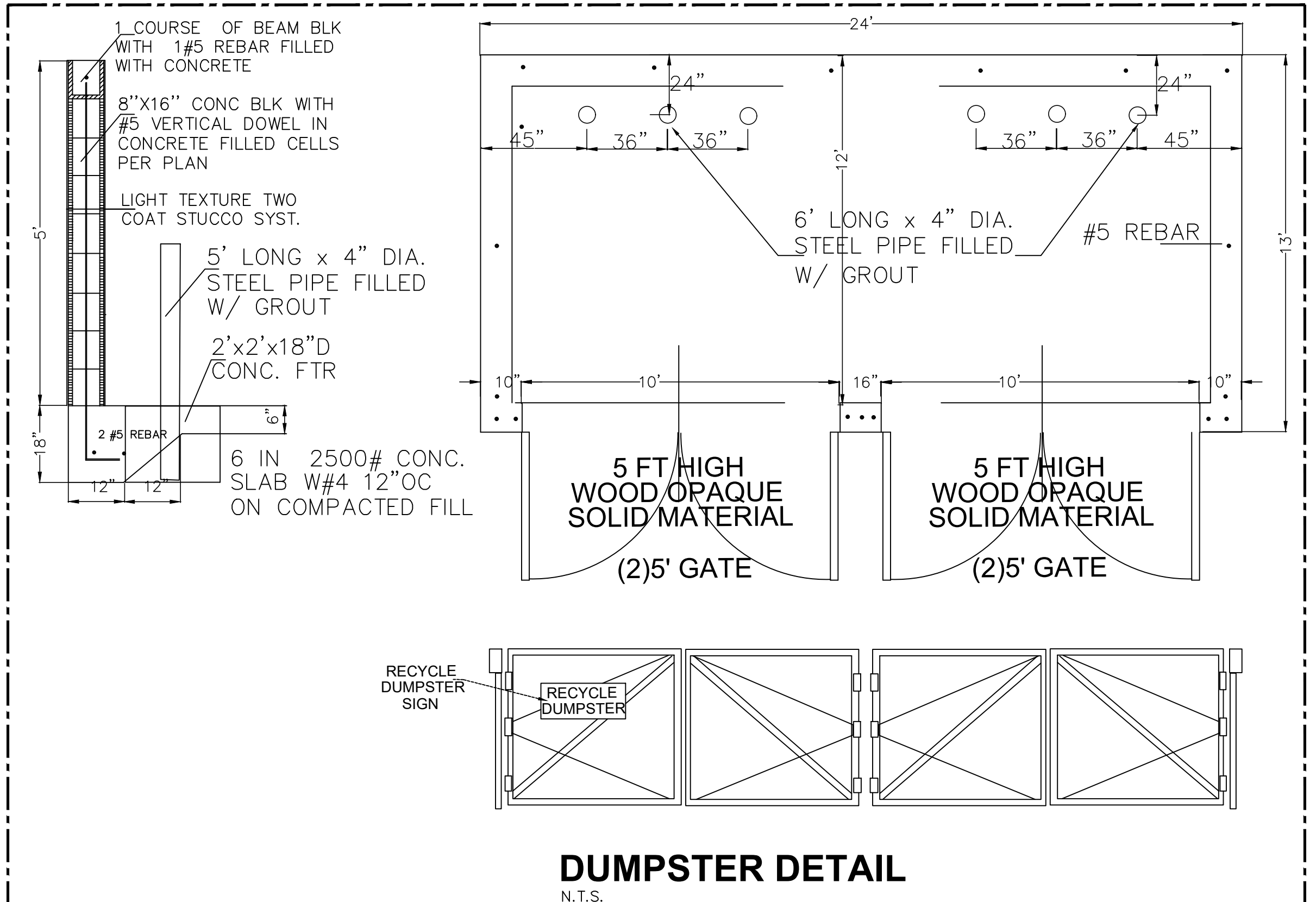

DUMPSTER DETAIL
N.T.S.



GARBAGE TRASH CAN DETAILS
N.T.S.

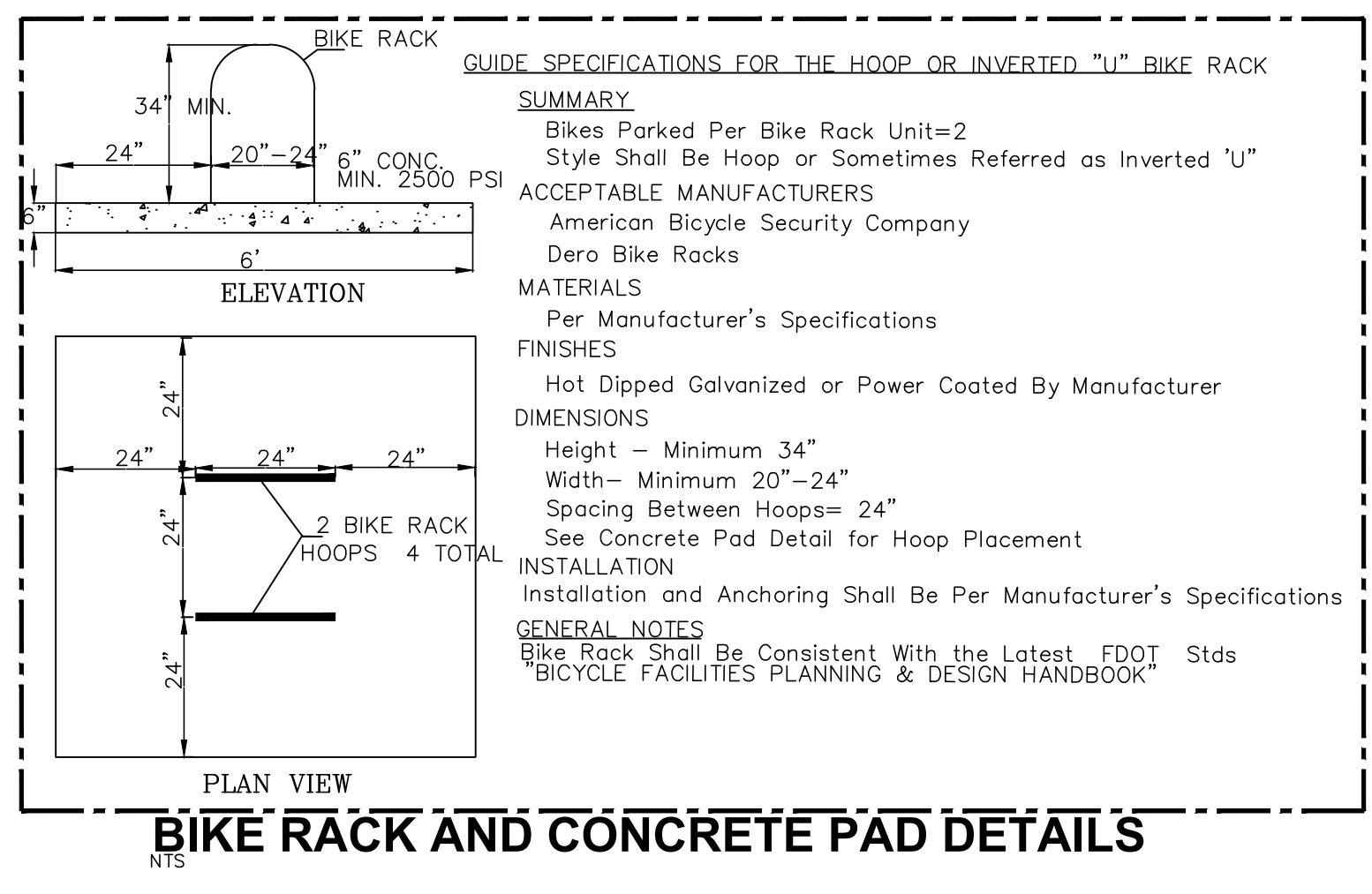

BIKE RACK AND CONCRETE PAD DETAILS
N.T.S.

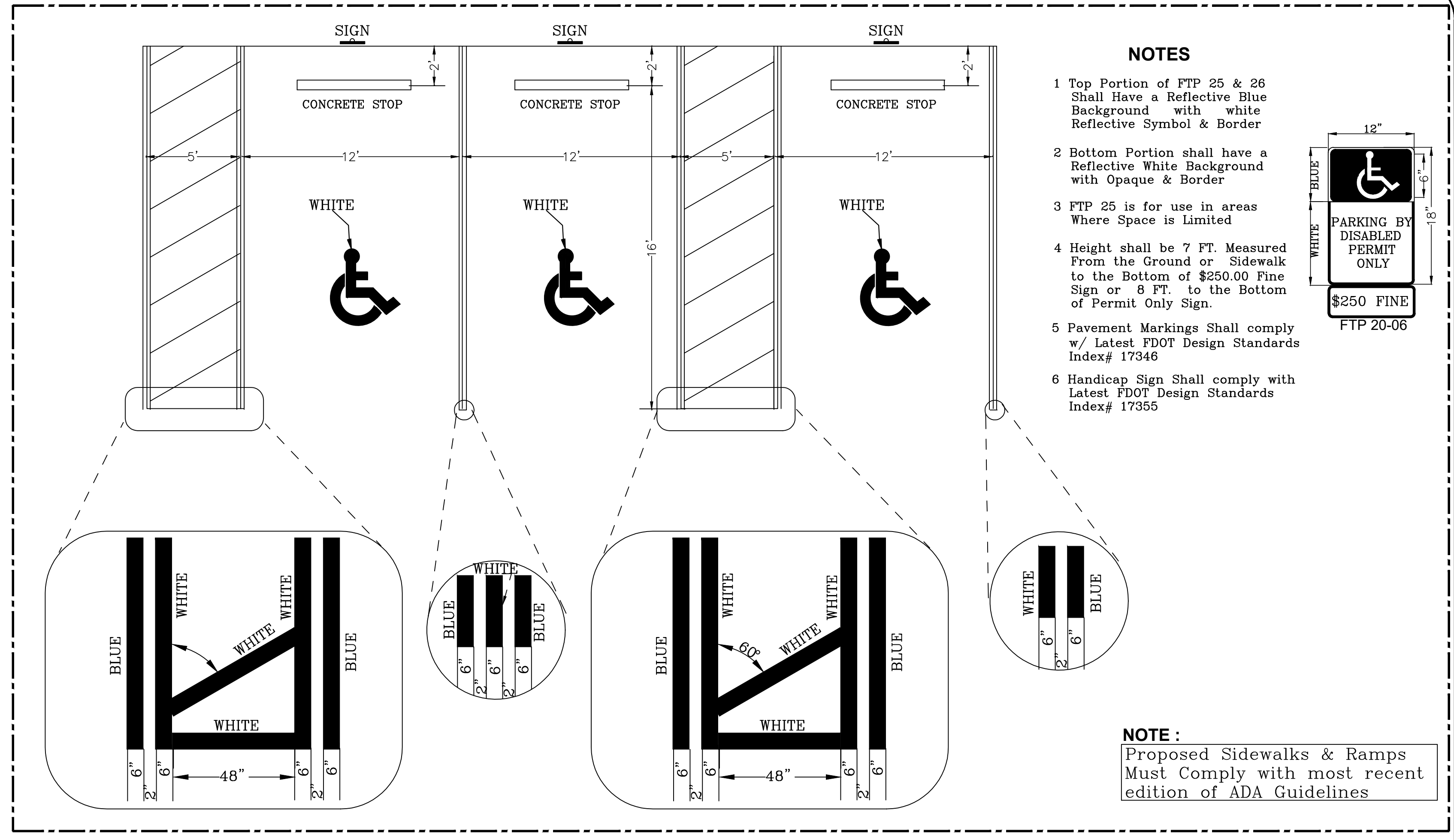

H.C. Pavement Markings and Signs shall comply with Latest FDOT Standards

H.C. PAVEMENT MARKING DETAIL
N.T.S.

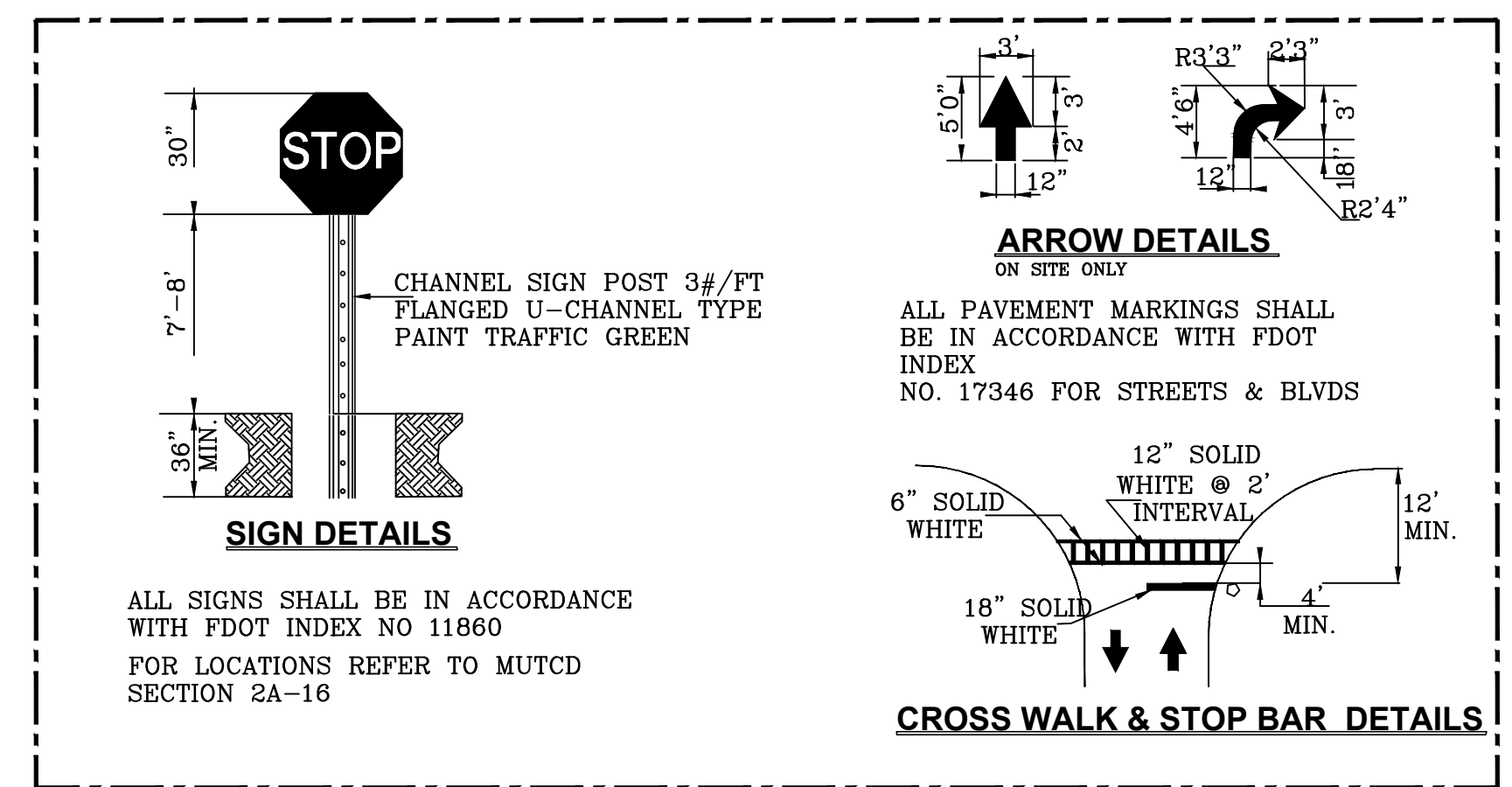

SIGN & PAVEMENT MARKING DETAILS
N.T.S.

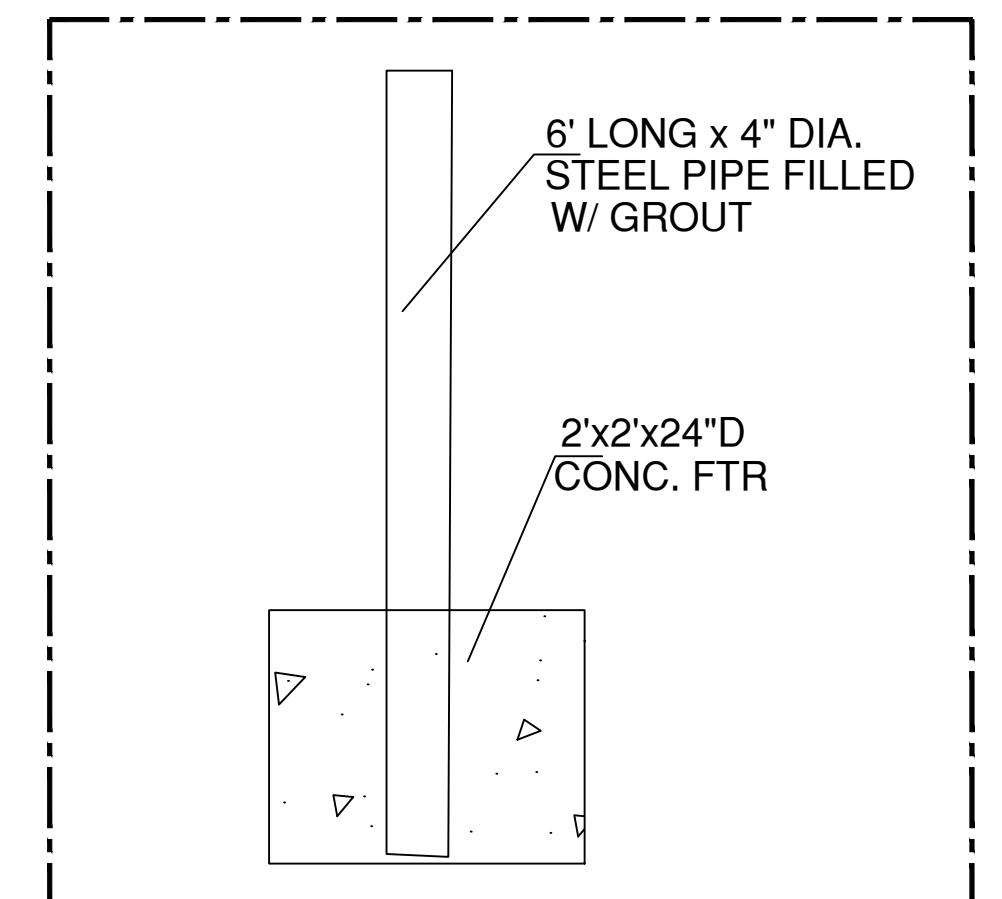

BOLLARD DETAIL
N.T.S.

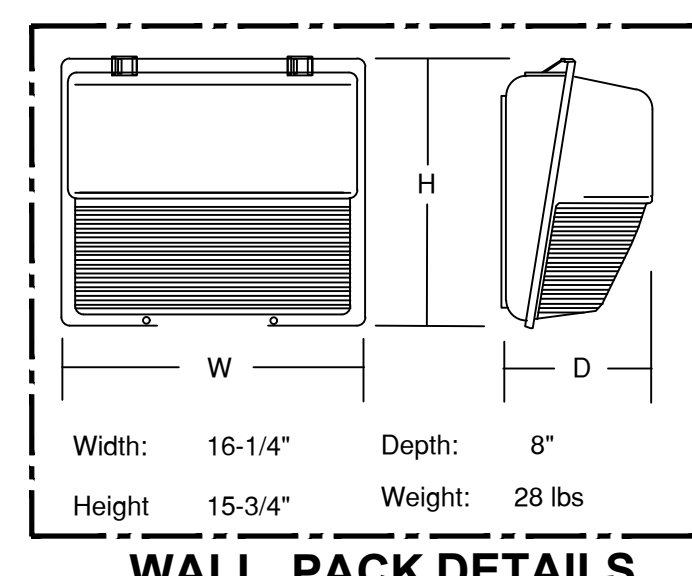

WALL PACK DETAILS

This item has been digitally signed & sealed by Abraham Chabab, PE

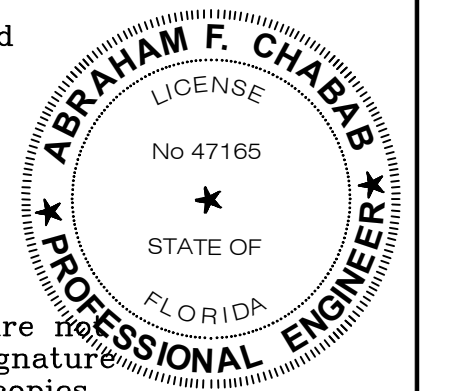

Printed copies of this document are considered signed & sealed & the signature must be verified on any electronic copies

 ABRAHAM CHABAB, Inc. FL. BOARD OF PROF. ENG. AUTH.#26790	HKA WAREHOUSE	DESIGNED BY AC	REVISIONS	DATE
		DRAWN BY AC		
		DATE Apr. 15/2024		
		SHEET 2 OF 2		
5019 NW RUGBY DRIVE PORT ST. LUCIE FL. 34983 Email agchabab1@msn.com Ph:(772)475-6630		CITY OF PORT ST. LUCIE PROJECT NO. P24-074		